

Web Site

- *<http://web.uvic.ca/~pkennedy/Courses/111/111.htm>*
- All information relating to the course can be found there.

1. Introduction and Overview

Introduction

- Globalization:
 - greater trade and investment between countries
 - international agreements and cooperation
- Good thing or bad?
- Proponents:
 - increased prosperity for all people through the cooperative pursuit of common goals

Introduction

- Opponents:
 - erosion of national sovereignty and culture
 - disruptive effects of increased global competition
 - potential for widespread environmental degradation

Introduction

- The middle ground:
 - the *potential* exists for universal prosperity through globalization
 - the realization of that potential will rely on the careful design of policy to manage change and to direct competitive forces for the common good

Introduction

- Goals of this course:
 - illuminate some of the key linkages between economic growth, international trade and the global environment
 - provide an understanding of why policy intervention is needed to manage these linkages
 - provide an introduction to the principles of policy design

1.1 The Economy and the Natural System

Short Run and Long Run Dynamics

- The natural system is a complex web of interconnected *dynamic processes* (both biological and geophysical).
- Some processes have relatively short dynamic cycles – such as seasonal weather patterns in a given region.
- Others have very long dynamic patterns – such as long run climatic changes.

Short Run and Long Run Dynamics

- The appearance of balance - or a steady state - is an illusion due to “snapshot” observation.
- Example:
 - climate change over the past 15,000 years has caused dramatic changes in weather patterns that would have appeared stable to any given generation

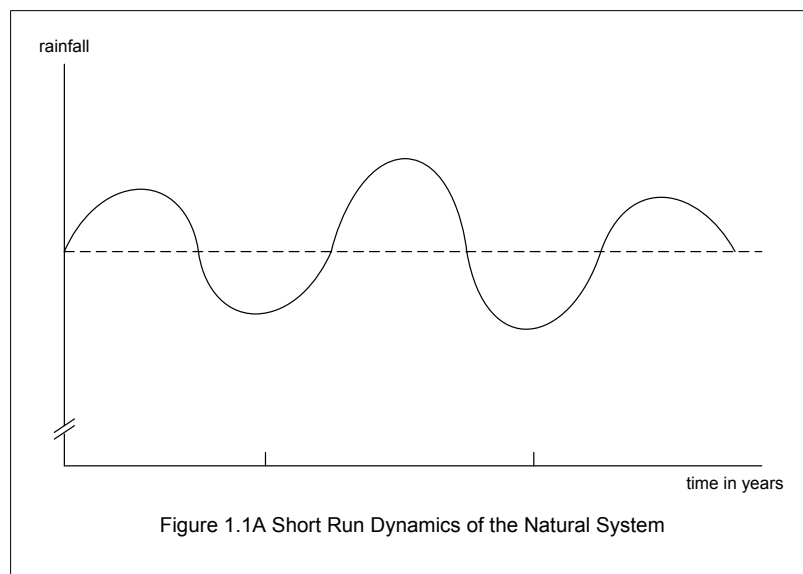
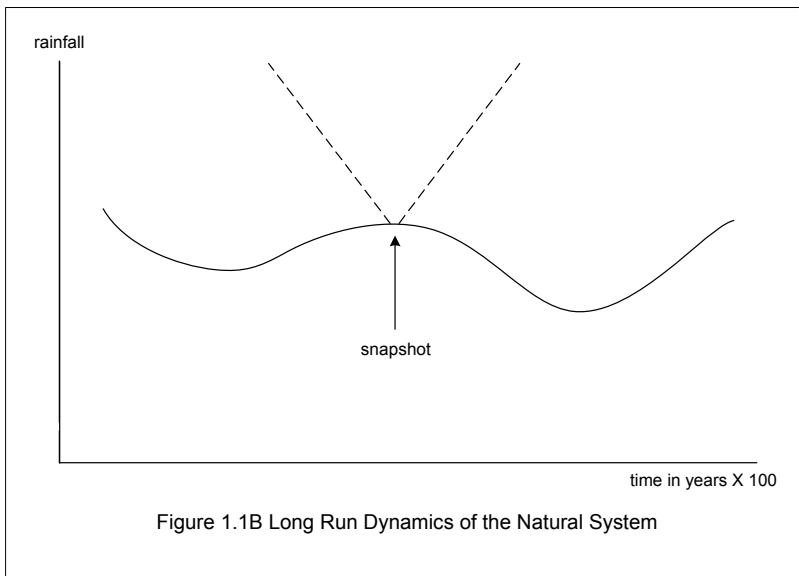

Figure 1.1A Short Run Dynamics of the Natural System



Tangent: Stochastic Systems & Chaotic Systems

- Suppose the state of a system is described by the variable x_t at some point in time, t .
- For example, x_t might be average global temperature.

Tangent: Stochastic Systems & Chaotic Systems

- A **stochastic system** has a truly random element, as if at least partly determined by the role of dice or the toss of a coin.
- A stochastic system is fundamentally unpredictable even if the stochastic process is known.

Tangent: Stochastic Systems & Chaotic Systems

- Example:

$$x_t = x_{t-1} + \varepsilon_t$$

- where ε_t is determined by the role of a die

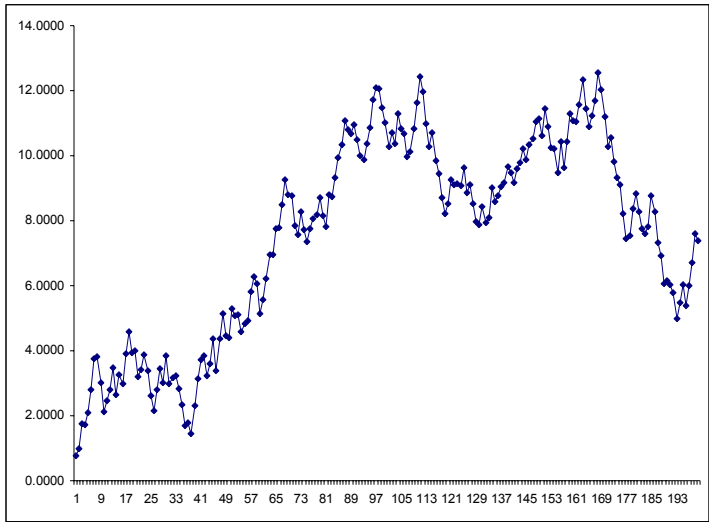

Growth, Trade and the Global Environment

15

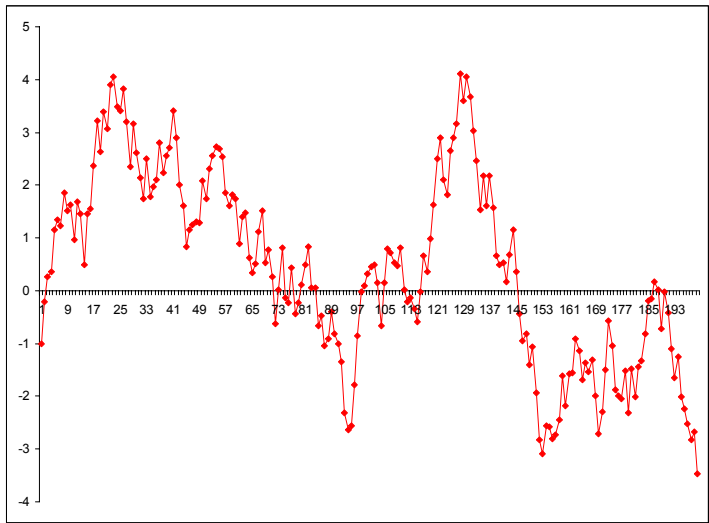

Growth, Trade and the Global Environment

16

Tangent: Stochastic Systems & Chaotic Systems

- A **chaotic system** is *deterministic* (not stochastic).
- In principle, it is predictable if the underlying dynamic process is known.
- In practice, the process is typically not known.

Tangent: Stochastic Systems & Chaotic Systems

- Example:

$$x_t = Ax_{t-1}(1 - x_{t-1})$$

- where A is a number.
- The behaviour of this system depends critically on the value of A .

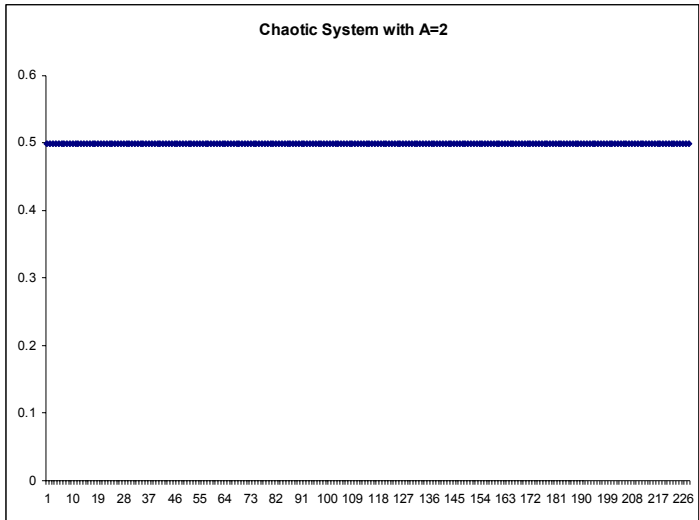

Growth, Trade and the Global Environment

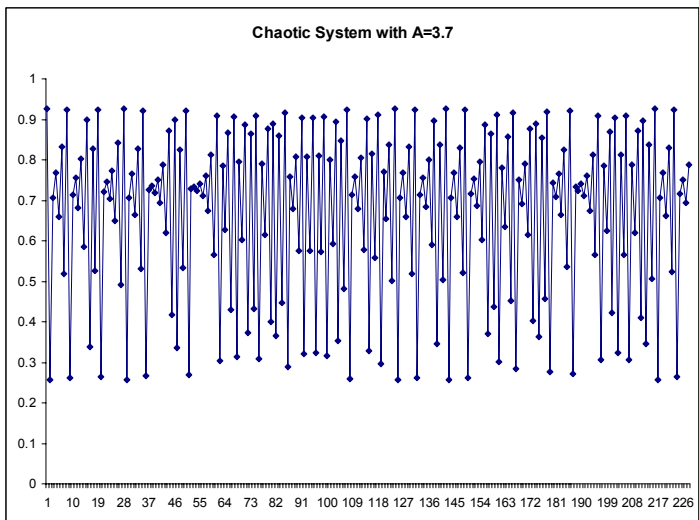

Growth, Trade and the Global Environment

Tangent: Stochastic Systems & Chaotic Systems

- A more complicated example:

$$x_t = Ax_{t-1}(1 - x_{t-1}) + Bt$$

- where B is a number (reflecting a time trend)

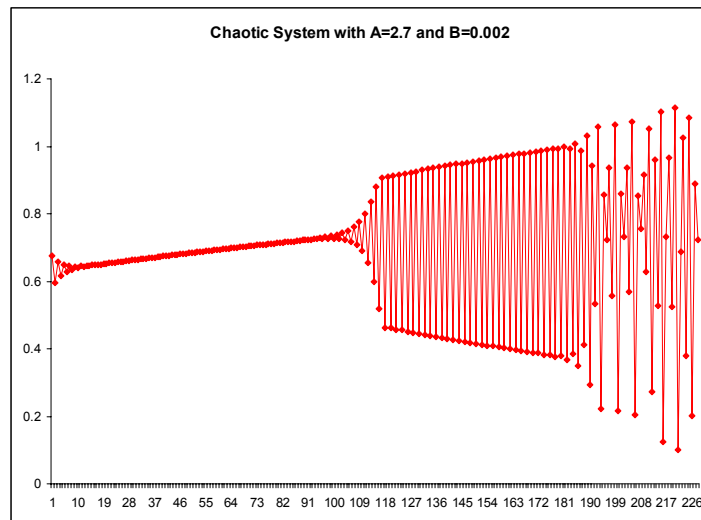

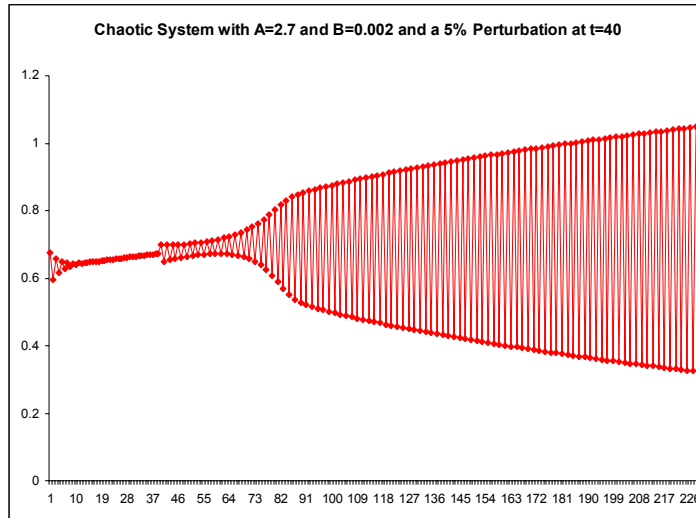

Growth, Trade and the Global
Environment

23

Short Run and Long Run Dynamics

- We should question common thinking on the interaction between economic activity and the environment.
- Example:
 - “human activity should not upset the natural balance of the earth”
- This is a simplistic and flawed foundation for policy.

Growth, Trade and the Global
Environment

24

Short Run and Long Run Dynamics

- Human activity does cause changes - sometimes dramatic changes - to the natural system and its underlying dynamics.
- Key point:
 - there is nothing *inherently* wrong or undesirable about the environmental impact of human activity.

Short Run and Long Run Dynamics

- Humans are an integral part of the natural system – not somehow separate from it – and the system evolves endogenously in response to human activity within that system.
- Human activity is *natural*; but natural is not necessarily good.

Short Run and Long Run Dynamics

- The economic criterion for assessing environmental impacts - anthropogenic or otherwise - is based on consequences:
 - *do they cause us harm (directly or indirectly)?*

Short Run and Long Run Dynamics

- Note that harm could be due to the rate of change in the system (too fast to allow adaptation); e.g. climate change?

Tangent: Pre-History

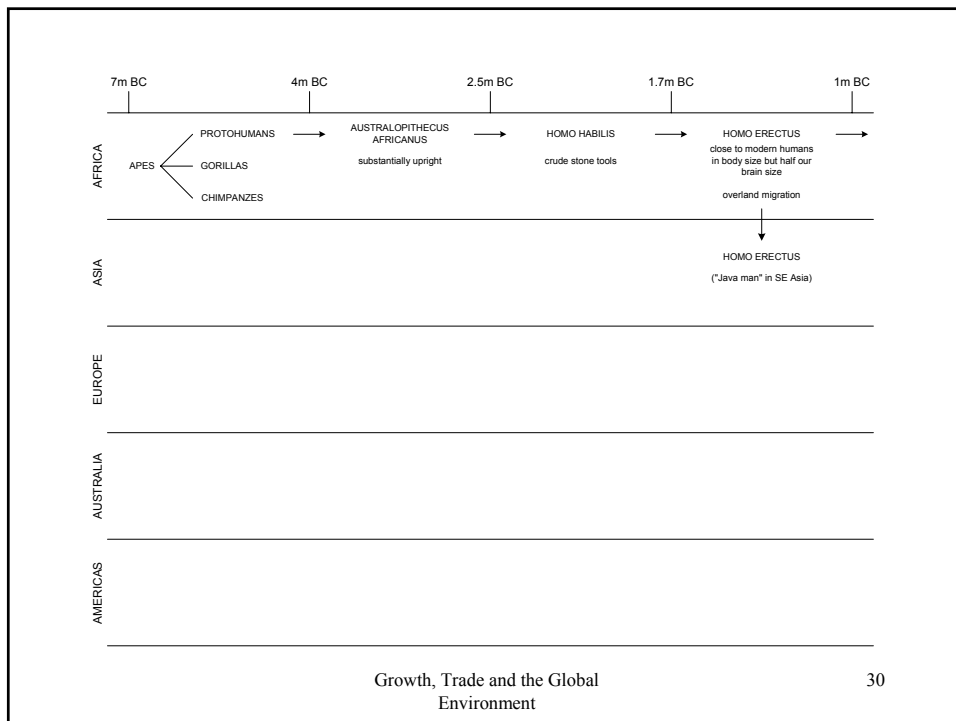

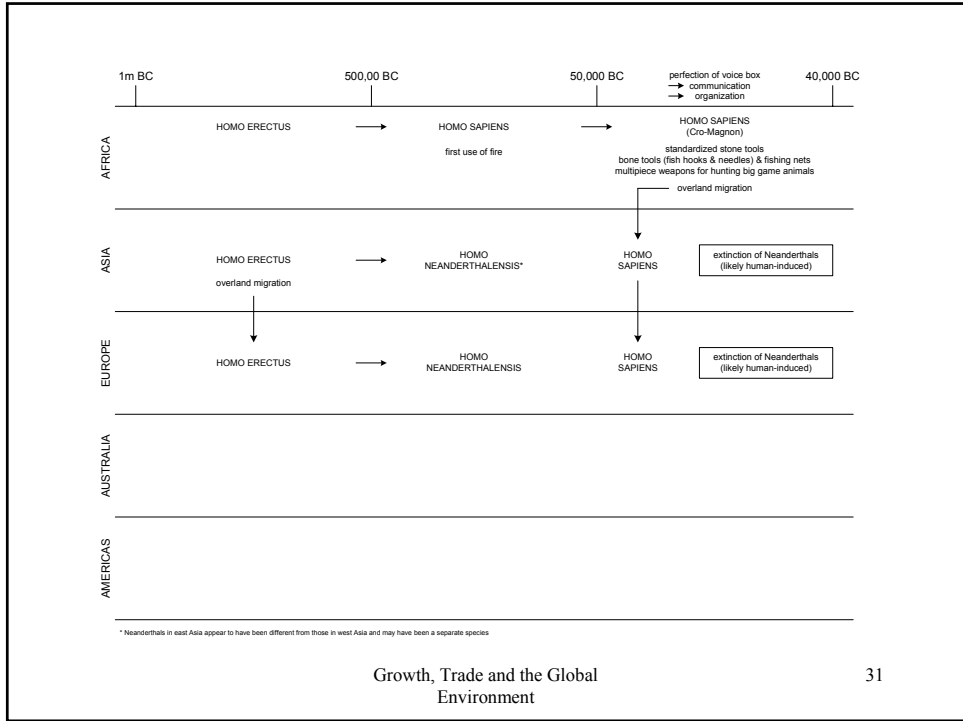

Growth, Trade and the Global Environment

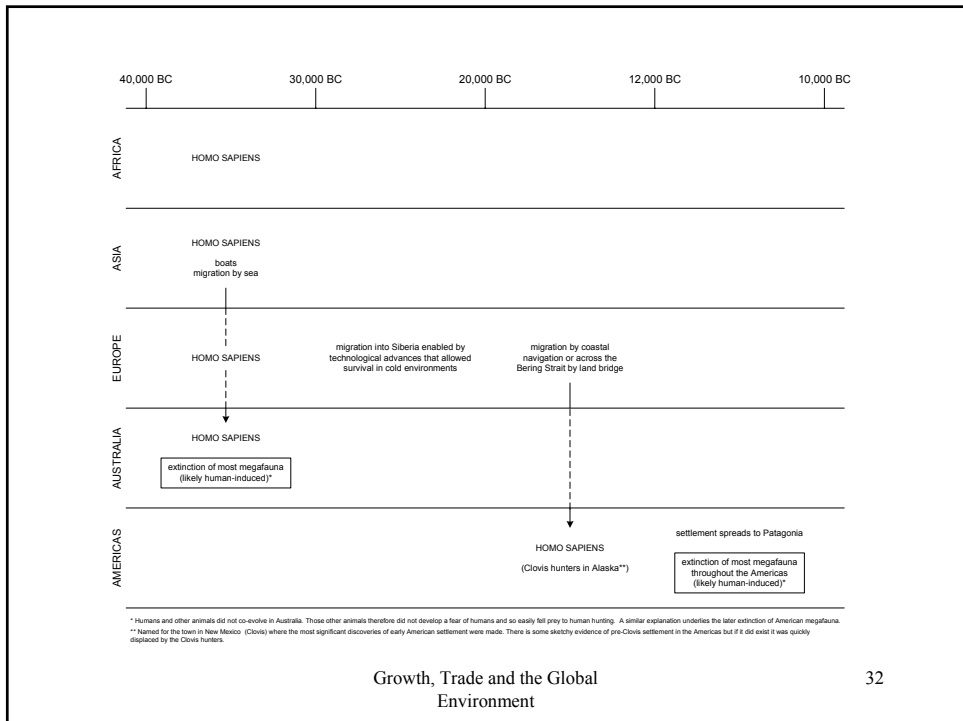

Growth, Trade and the Global Environment

Natural Capital and Economic Activity

- The economy draws upon *natural capital* and reconfigures that natural capital to produce services that satisfy human wants.

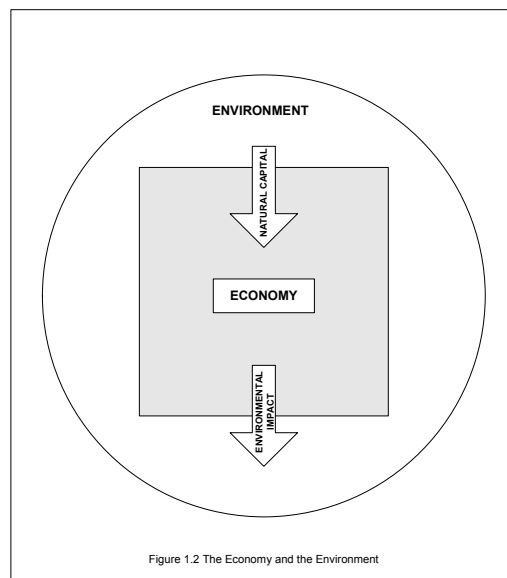

Figure 1.2 The Economy and the Environment

Natural Capital and Economic Activity

- Example:
 - clear forested land for growing crops for food
- Primary impact (deliberate):
 - conversion of landscape
- Incidental environmental impact:
 - loss of habitat for forest dwelling animals;
potentially harmful

Natural Capital and Economic Activity

- In some cases the benefits of the primary activity may outweigh the harm done by incidental environmental impacts.
- In other cases they may not, but the activity might occur anyway; why?
 - incomplete information
 - externalities

Natural Capital and Economic Activity

- Both factors can lead to undesirable outcomes from a social perspective; implies a role for policy intervention.

Assimilative Capacity and Limits to Growth

- Will economic activity eventually use up all natural capital and come to a grinding halt?
- To think about this question we need two important concepts:
 - assimilative capacity
 - knowledge capital

Assimilative Capacity and Limits to Growth

- Illustrative example of **assimilation**:
 - harvest biomass from plants to burn as fuel
 - combustion process combines oxygen with the hydrocarbons from the biomass to produce heat
 - among the by-products: water vapor and carbon dioxide

Assimilative Capacity and Limits to Growth

- carbon dioxide is captured by plants and combined with water to produce biomass via photosynthesis
- sunlight provides the energy for the photosynthesis process
- photosynthesis recycles – or *assimilates* – the by-products released from the combustion process

Tangent: Combustion of Fossil Fuels

- Example: natural gas (methane)

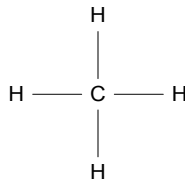
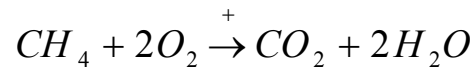

Growth, Trade and the Global Environment

41

Assimilative Capacity and Limits to Growth

- Material is continually recycled through the natural system via biological and physical processes.
- The recycling processes are powered by solar energy (rare exceptions: geothermal energy).

Growth, Trade and the Global Environment

42

Assimilative Capacity and Limits to Growth

- Recycling properties of the natural system are crucial to the sustainability of economic activity.
- However, the rate at which the system can recycle material is limited; it has finite *assimilative capacity*.

Assimilative Capacity and Limits to Growth

- Anthropogenic environmental changes occur when the rate of reconfiguration of natural capital exceeds the assimilative capacity of the natural system.
- Important example:
 - anthropogenic climate change due to carbon dioxide emissions from fossil fuel combustion

Assimilative Capacity and Limits to Growth

- Limited assimilative capacity places limits on the rate at which economic activity can utilize natural capital without perturbing the natural system.
- This does not necessarily mean that there are limits to growth in economic services.

Assimilative Capacity and Limits to Growth

- Economic services are produced by combining natural capital with *knowledge capital*.
- Key to sustainable growth: the substitution of knowledge capital for natural capital.

Assimilative Capacity and Limits to Growth

- The problem for policy-makers is to ensure that environmental impacts are not ignored in the quest for economic growth.
- Complex problem made even more complicated by the web of international linkages between national economies and national environments.

Assimilative Capacity and Limits to Growth

- Those linkages are a key focus of this course.
- Let us begin with an overview.

1.2 International Environmental Linkages

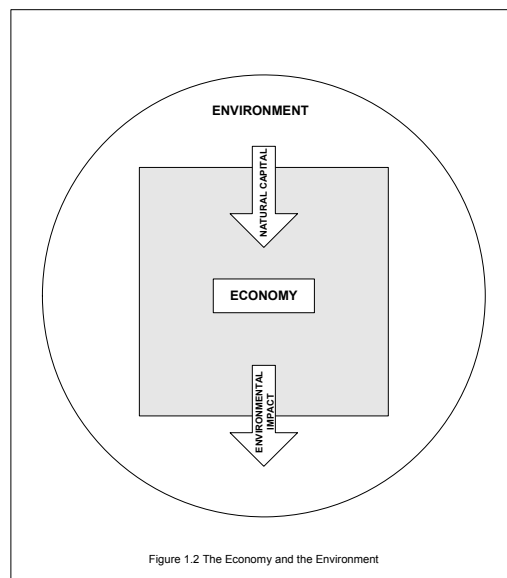

Growth, Trade and the Global Environment

50

International Environmental Linkages

- Two important sets of international environmental linkages:
 - transboundary environmental impacts
 - trade and investment

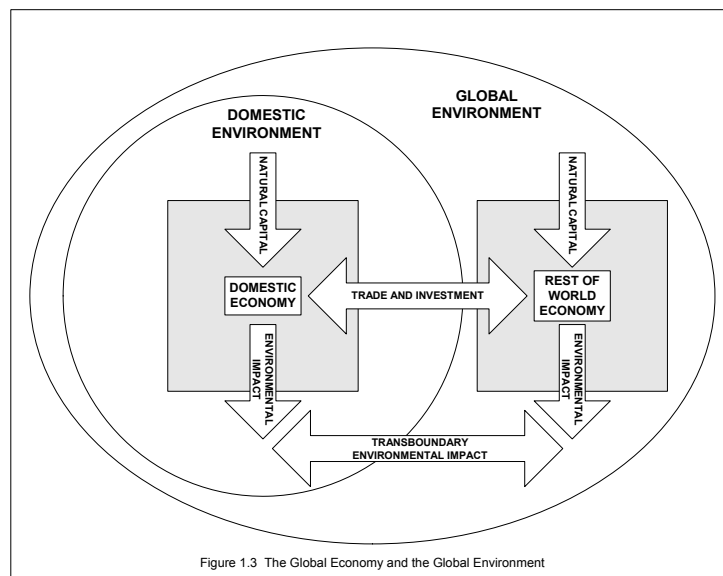

Figure 1.3 The Global Economy and the Global Environment

Transboundary Environmental Impacts

- Important examples:
 - global climate change (via carbon dioxide and other greenhouse gas emissions)
 - stratospheric ozone depletion (via emissions of chloroflourocarbons and related substances)
 - oceanic pollution
 - biodiversity loss

Transboundary Environmental Impacts

- airborne pollutants such as particulates (including heavy metals)
- sulfur dioxide and nitrous oxides
- persistent organic pollutants

Tangent: Mercury Pollution

Tangent: Mercury Pollution

- Mercury is a **neurotoxin**: it damages the central nervous system.
- Exposure in adults can cause memory loss and tremors (as well as cardiac and reproductive problems).
- Prenatal and infant exposure can cause mental retardation, deafness and blindness.

Tangent: Mercury Pollution

- Mercury is readily absorbed by animals in the form of methylmercury (a compound of mercury, carbon and hydrogen).
- It is bioaccumulative: it accumulates in animals as it works its way up the food chain.

Tangent: Mercury Pollution

- Methylmercury is water-soluble; hence its bioaccumulation is most pronounced in fish.
- The primary anthropogenic source of mercury – about 40% in the US – is the combustion of coal:
 - mercury emissions enter the atmosphere and are then carried into water sources by rain and snow.

Tangent: Mercury Pollution

- Hydroelectric projects can also release mercury into the water (via exposure of mercury-containing rock to reservoir water).
- Mercury is a transboundary pollutant: it can be carried great distances away from the point source. #

Transboundary Environmental Impacts

- A key focus of this course:
 - interplay between transboundary environmental impacts and trade.
- A number of important aspects to this:
 - relationship between international agreements and the transfer of technology
 - concerns about the impact of compliance with those agreements on competitiveness

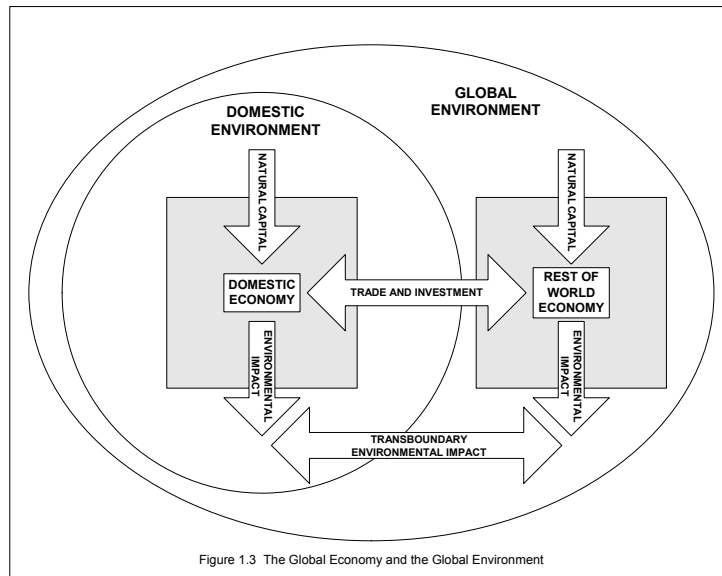

Figure 1.3 The Global Economy and the Global Environment

International Trade and Investment

- Two key components to this linkage:
 - the impact of trade on the environment
 - the impact of environmental policy on trade

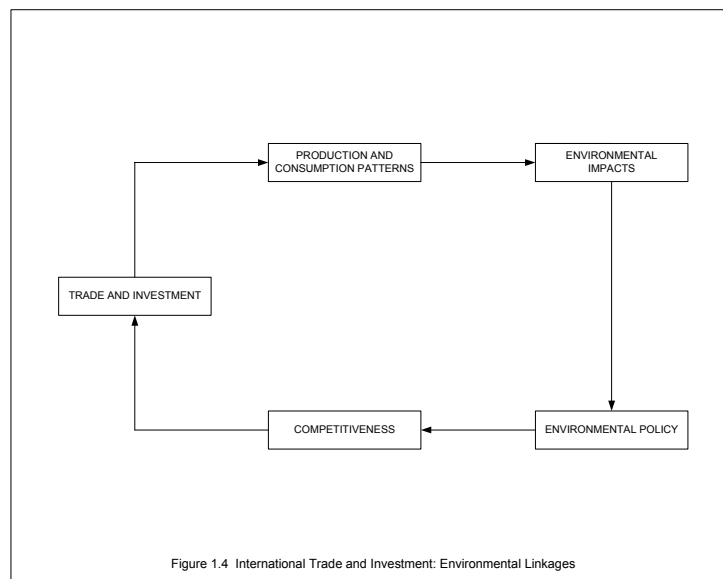

Figure 1.4 International Trade and Investment: Environmental Linkages

The Impact of Trade on the Environment

- The pattern of trade between countries affects the production and consumption patterns *within* countries.
- These production and consumption patterns in turn determine environmental impacts.

The Impact of Trade on the Environment

- Trade liberalization – and globalization generally – can cause significant shifts in environmental impacts due to the affect on consumption and production patterns.
- Especially rapid in many developing countries.

The Impact of Trade on the Environment

- Linkage is complicated by
 - geographical separation between production and consumption associated with trade
 - jurisdictional separation between policy-makers

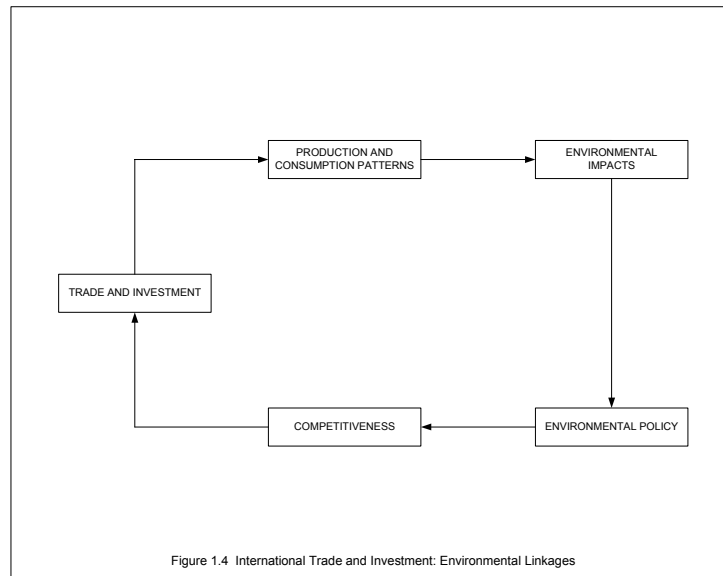

Figure 1.4 International Trade and Investment: Environmental Linkages

The Impact of Environmental Policy on Trade

- Domestic environmental policy has an impact on competitiveness which in turn affects trade flows.
- These trade-related effects of environmental policy can in turn potentially distort how environmental policy is set:
 - potential for a “race to the bottom”

The Impact of Environmental Policy on Trade

- The problem can in principle be resolved through international coordination
 - example: NAFTA Commission for Environmental Cooperation (www.cec.org)
- Well-designed policy is crucial if the benefits of trade are to be fully realized.

1.3 Trade and the Environment in Developing Countries

Trade and the Environment in Developing Countries

- Trade liberalization has fostered enormous recent growth in the manufacturing sectors of many developing countries (especially in Asia and Latin America).
- Two sources of *comparative advantage* in these countries:
 - a relative abundance of low-skill labor
 - relatively high environmental impact tolerance

Trade and the Environment in Developing Countries

- Higher environmental impact tolerance does *not* arise from lower physical impacts.
- Differences arise from how those impacts are valued.
- The economic notion of *environmental harm* or *damage* is based on value.

Trade and the Environment in Developing Countries

- Three factors underlie the differences in environmental impact tolerances across countries:
 - systematic differences in preferences (value systems)
 - differences in population numbers
 - differences in wealth

Trade and the Environment in Developing Countries

- The valuation of high environmental quality generally increases with the level of wealth.
- The lower level of wealth in developing countries is the primary source of their comparative advantage in relatively polluting industries.

Trade and the Environment in Developing Countries

- Environmental policy design must recognize existing wealth differences regardless of how “immoral” one might believe those wealth differences to be.
- Optimal environmental policy must be tailored to the particular country concerned based on values in that country.

banning child labour, may hurt those countries

End

2. The Environmental Effects of Production and Consumption

2.1 Introduction

Introduction

- Changes in trade and investment flows can have dramatic effects on production and consumption patterns within an economy, which in turn can cause significant changes in environmental impacts.

Introduction

- In this chapter we take a closer look at resource flows within an economy, focusing on the links between natural capital, production and consumption.
- We then outline some of the most important types of environmental impacts associated with production and consumption activities.

Introduction

- We conclude with a brief discussion on uncertainty and irreversibility.

2.2 Resource Flows in the Economy

Resource Flows in the Economy

- Fundamental relationship between the economy and the environment:
 - the economy ^{activity} draws upon natural capital to produce valuable services, and through the reconfiguration of that natural capital creates environmental impacts.

always left over effects

Growth, Trade and the Global Environment

7

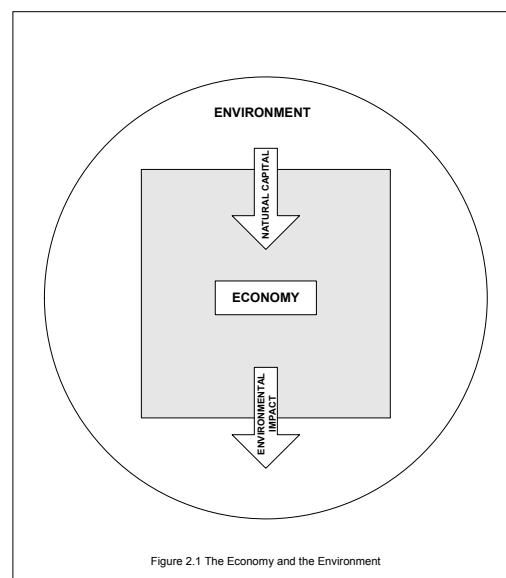

Figure 2.1 The Economy and the Environment

Growth, Trade and the Global Environment

8

Resource Flows in the Economy

- Now let us consider the flow of resources in more detail.

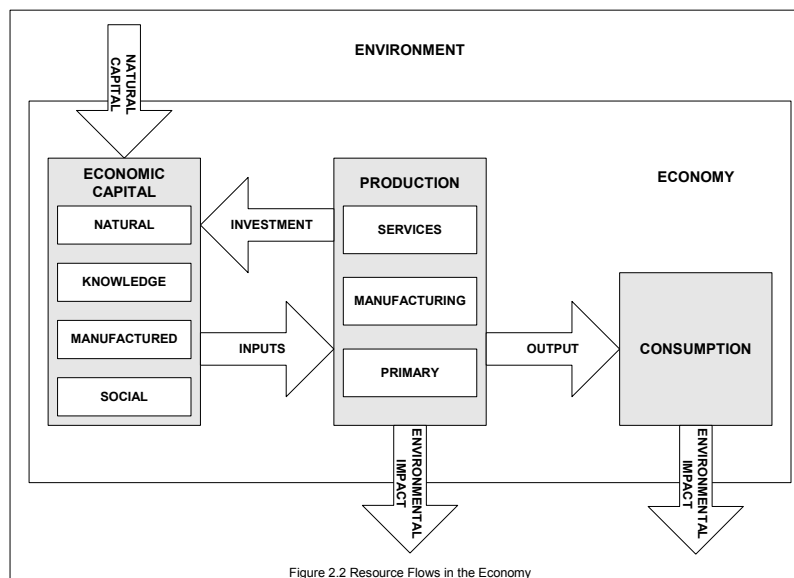

Economic Capital

- The utilization of natural capital allows the production of other forms of economic capital:
 - knowledge capital
 - manufactured capital
 - social capital
- Together with natural capital, these form the *productive inputs* of the economy.

Knowledge Capital

- Knowledge capital constitutes the stock of human knowledge, and is therefore sometimes referred to as “human capital”. won't use this reference
- Knowledge capital holds the key to the possibility of continued growth in human living standards despite the limits on the capacity of natural capital.

find ways to use natural capital better - only way to keep going, must be limits eventually
can give to many people at the same time/ not divided up/ such as an item - very handy

Manufactured Capital

- Manufactured capital constitutes the stock of infrastructure, buildings and equipment that is sometimes called “physical capital”.
constructed
embodies knowledge
does not use it up
many ppl can access
- Traditional cornerstone of industrial economies.
- Note that manufactured capital embodies knowledge but is distinct from the stock of knowledge itself.

Growth, Trade and the Global Environment

13

Social Capital

- Social capital constitutes the stock of social norms, laws and other social institutions that allow individuals to interact and cooperate in the production of economic services.
tuition for a class - teacher must be there or else breach of contract
exchange of money for service
- Some of the most serious threats to the environment around the world stem from social and political breakdown.
absence of policy enforcement

Growth, Trade and the Global Environment

14

Social Capital

- The absence of strong political and judicial systems can pose a serious impediment to the functioning of markets and to the design and implementation of effective policy.

luxury in countries that do have it

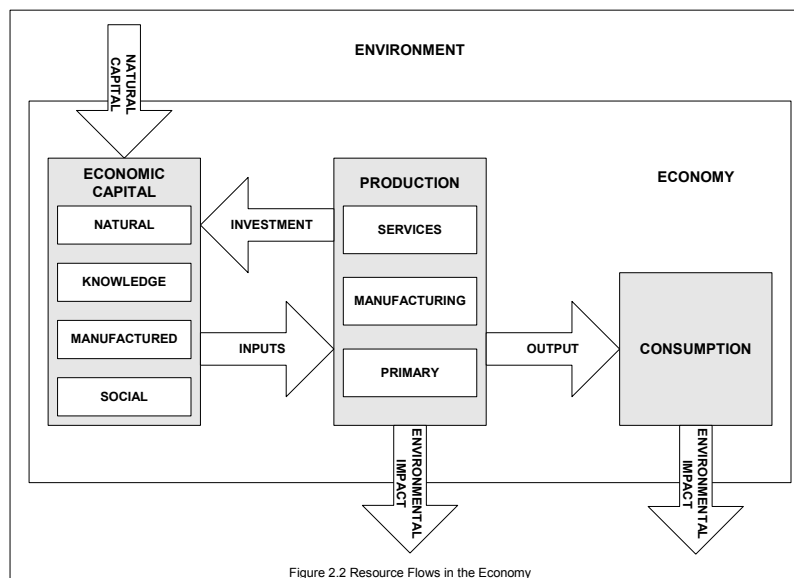

Figure 2.2 Resource Flows in the Economy

Production

no hard fast line between them - grey areas

- Economic capital (natural capital, together with knowledge, manufactured and social capital) provides the inputs into production.
- It is usual to classify production into economic *sectors*:
 - primary production
 - manufacturing (or secondary production)
 - services (or tertiary production)

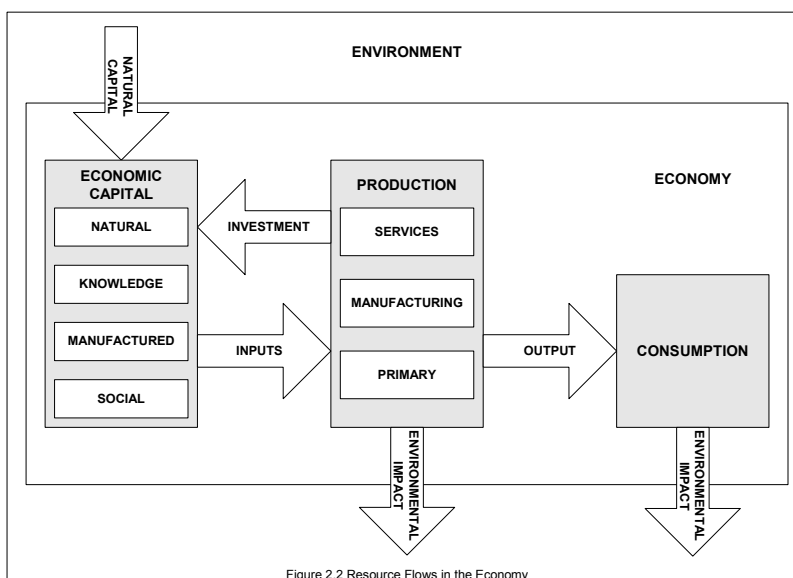

Figure 2.2 Resource Flows in the Economy

Primary Production

- Primary production comprises those activities that are least removed from their natural capital base, including
 - agriculture resource industries
 - fishing
 - hunting
 - forestry
 - mining if had the refinery on site- may become secondary industry - grey line

Manufacturing

- Manufacturing applies varying degrees of additional processing to the outputs of primary production. add value through processing
- Some outputs are used to provide direct consumption services (“final goods”) while others act as inputs into other manufacturing processes (“intermediate goods”).

Manufacturing

- Manufacturing typically uses knowledge and manufactured capital more intensively as inputs than does primary production.

primary production more closer tied to natural capital

The Service Sector

- The service sector provides direct services for consumption (such as the entertainment industry) and as an input into production (such as computer programming or the financial services sector).
- This sector is typically the most knowledge intensive of the three sectors.

doesn't mean don't use natural or manufactured capital, just rely more heavily on knowledge

Investment

- Part of the output from production is devoted to investment:
 - the maintenance and augmentation of economic capital (adding to)

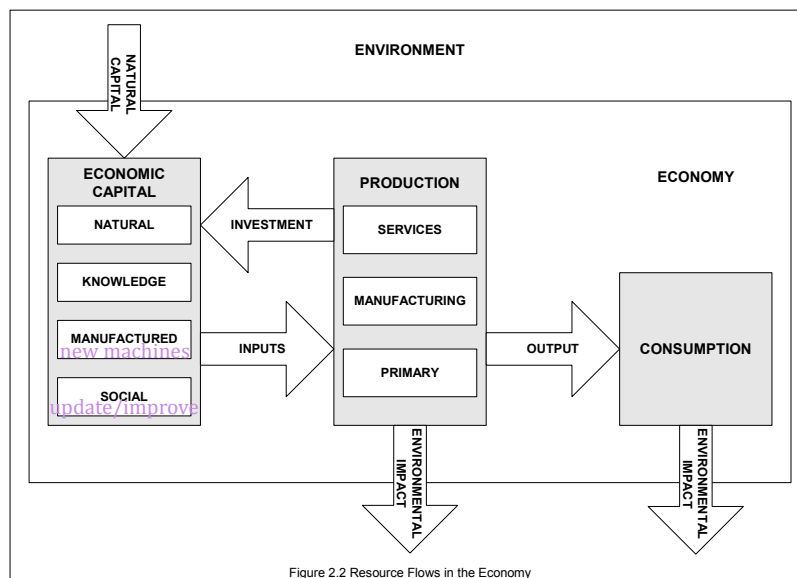

Figure 2.2 Resource Flows in the Economy

Investment

- without investment - cannot grow
Investment is the key to growth:
 - a sustained rate of increase in living standards can only be achieved with sustained growth in economic capital

growth is GOOD always - improvement in human living standards

Investment

- Long term sustainable development requires GROWTH investment in the maintenance of natural capital, and in the accumulation of knowledge and social capital:
 - the development of production methods and social structures that are able to generate greater human happiness with less material input.

Consumption

- The output from production that is not invested is consumed.

plant seeds to grow a crop - some is consumed, some is planted for next year (investment)

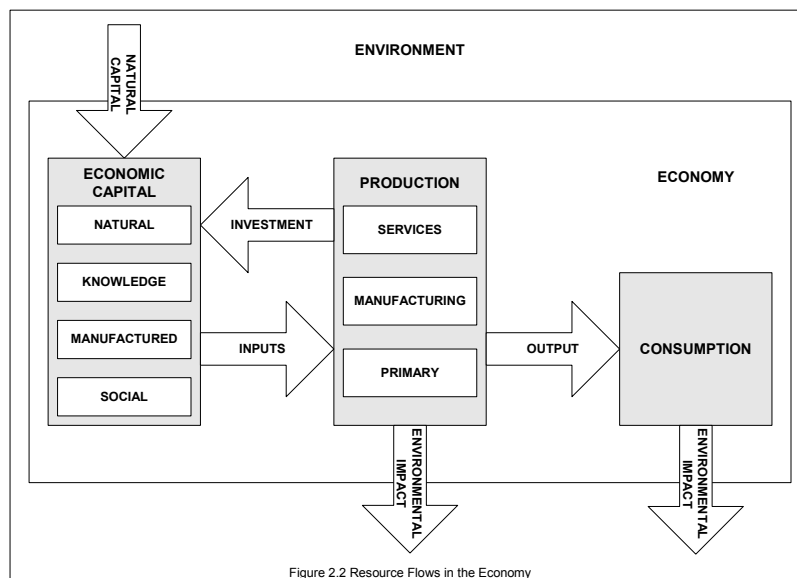

Figure 2.2 Resource Flows in the Economy

Consumption

- Consumption does *not* simply mean the acquisition and devouring of material goods. consumption means the production of services that generate happiness does not have to mean consuming more material
- Consumption in the economic sense refers to the utilization of economic capital - either directly or indirectly through produced goods and services - to generate happiness (or *utility*). cellphones now have more abilities - therefore greater utility no more material, but greater utility

Consumption

- No necessary link between the amount of material devoured in consumption and the happiness derived therefrom.
- Thus, there does not have to be a conflict between sustained consumption growth and the finite capacity of natural capital.

Consumption

- However, such a conflict must inevitably arise if increased consumption growth relies too heavily on material throughput relative to the utilization of knowledge and social capital.

need to better use natural capital

2.3 The Environmental Effects of Production

The Environmental Effects of Production

- The environmental impacts associated with production vary by type and degree across different sectors.
- This differentiation across sectors is a key consideration in examining the impact of trade on the environment, since trade can cause dramatic sectoral shifts in the distribution of production.

economic impact can change based on which industry is being used more

2.3-1 Primary Production

- The environmental effects of primary production are typically tied quite closely to industry type.
- It is therefore useful describe those impacts according to the main primary production industries.

fishing, agriculture, mining

Agriculture: Some examples

- antibiotic resistance: antibodies no longer as effective
need to create new antibodies
 - due to routinely used excessive use of antibiotics in livestock.
if one gets infected, all get infected as in close proximity - so antibiotics for all
- carbon release to the atmosphere:
 - due to burning and soil tillage.
- methane gas emissions: more potent than carbon dioxide
sheep farts in New Zealand
 - due to enteric fermentation in livestock and vegetative decay in rice paddies.

Agriculture: Some examples

- vegetative diversity loss:
 - due to less type being farmed concentration in specific seed varieties.
- water pollution:
 - elevated biological oxygen demand (BOD) and bacterial contamination due to animal excrement algae blooms with phosphate and nitrogen only
big prob near farms where fertilizer used
 - eutrophication due to phosphate- and nitrogen-rich fertilizer use

Fishing: Some Examples

- by-catch impacts: fish caught that was not meant to be caught
 - adverse impacts on by-catch populations (including marine mammals).
- stock depletion:
 - due to over-fishing. fishing faster than population can repopulate north atlantic - cod
- water pollution:
 - due to chemical fishing techniques (such as the use of cyanide). economic extinction - so few fish, not worth trying to catch vs biologic extinction (rare from fisheries) south east asia cyanide in water - kills everything - net from surface

Fishing: Some Examples

- wild stock diversity loss:
 - due to accidental releases from fish farms. atlantic salmon in pacific

- habitat destruction
 - due to dragnet fishing techniques
 - drag net and scoop everything - put back what don't need/want
 - dynamite fishing south east asia

Forestry: Some Examples

- biological diversity loss:
 - due to single-species tree-farming and loss of old growth.
- habitat loss:
 - due to displacement of native species by landscape changes.

forest rotation - harvesting trees and rotating growing / logging

plant-----harvest----- x time
 plant -----harvest-----x time
 plant-----harvest-----x time

Growth, Trade and the Global Environment

logistic function see notes

39

Forestry: Some Examples

- soil erosion and landslides:
 - due to road-construction and harvesting in steep terrain.
- stream silting:
 - associated with soil erosion (a major cause of flooding and fish habitat loss).

Mining, and Oil and Gas Extraction: Some Examples

- air pollution (especially greenhouse gases and volatile organic compounds):
 - due to gas flaring and vapour leakage
- habitat disruption:
 - due to on-site intrusion and road construction.

Mining, and Oil and Gas Extraction: Some Examples

- soil contamination:
 - due to spillage.
- water pollution:
 - due to spillage, heavy metal separating agents, and acidification from tailings ponds drainage and abandoned mine shafts.

2.3-2 Manufacturing

- The environmental effects of manufacturing are less industry-specific than in the primary production sector, and the sources of pollution are much more diverse.

Manufacturing

- For manufacturing it is therefore more useful to describe the main environmental impacts according to type:
 - air and water pollution
 - soil and groundwater contamination
 - solid waste

Air Pollution and Water Pollution

- Air and water pollutants can be classified according to the degree to which they are
 - uniformly mixed versus non-uniformly mixed
 - dissipative versus cumulative

- these distinctions are important for the design of policy
have to be able to communicate with experts in the field to prove a plan

Uniformly Mixed Pollutants

SEE NOTES

- Uniformly mixed pollutants are those that become dispersed uniformly over the receptive region (such as an airshed or a lake).
- Examples in the case of air pollution:
 - volatile organic compounds (VOCs) from fossil fuel use, and paints and solvents

Uniformly Mixed Pollutants

- global pollutants such as carbon dioxide (e.g., from fossil fuel combustion) and chloroflourocarbons (CFCs) (used as refrigerants, aerosol propellants, and solvents).

very difficult to regulate with international treaties

Non-Uniformly Mixed Pollutants

wind moves the pollutants, and may move them away from source

- Non-uniformly mixed pollutants tend to pool around sources, and so form “hot spots” within a receptive region. ex. fraser valley
- Examples in the case of air pollution:
 - suspended particulates
 - sulphur dioxide (SO₂) and nitrous oxides (NO_x)

tangent

- photochemical smog is tropospheric ozone, O₃

-formed when O₂ is exposed to sunlight in the presence of VOC and nitrous oxides (NO_x)

-both of these pollutants must be present in ozone to form

SEE NOTES

Fixed Proportions

-ozone causes respiratory problems - asthma attacks, crop damage and materials damage - stone
-management is made difficult by the fact that VOC's is uniformly mixed while nitrous oxides are non-uniformly mixed.

Non-Uniformly Mixed Pollutants

- Most water pollutants tend to be non-uniformly mixed. Examples:
 - BOD sources (such as sewage wastewater)
 - organochlorines (e.g. from pulp and paper mills)
 - oil and industrial solvents
 - heavy metals (such as mercury)

River Clyde - industrial activity - dredged it and found very toxic sediments at bottom

Dissipative Pollutants

SEE NOTES

- Dissipative pollutants are those whose damaging impact is relatively short lived.
- They are assimilated reasonably quickly, but not so quickly as to cause no damage.

Dissipative Pollutants

short lived

- Examples in the case of air pollution:
 - suspended particulates
 - VOCs
 - sulphur dioxide and nitrous oxides

Dissipative Pollutants

- Examples in the case of water pollution:
 - biological oxygen demand sources
 - oil and some industrial solvents
- Note that dissipative pollutants can be uniformly or non-uniformly mixed.

Cumulative Pollutants

- Cumulative (or persistent) pollutants are those that build up in the environment over time; they are sometimes called “stock pollutants”. SEE NOTES
- These pollutants are assimilated very slowly, and the damage done by emissions in any given period depends on the volume of emissions in previous periods.

no can do nothing to affect climate change over years due to stock of CO2

Cumulative Pollutants

- Examples in the case of air pollution:
 - radioactive emissions
 - lead
 - CFCs input almost zero now, but have stock from previous years
 - carbon dioxide

Cumulative Pollutants

- Examples in the case of water pollution:
 - ^{last 50-60 years} organochlorines and heavy metals (which tend to accumulate in animal body fats)
- Note that cumulative pollutants can be uniformly or non-uniformly mixed.

Air Pollution and Water Pollution

- ^{*****} Note that the degree to which a particular pollutant is uniformly or non-uniformly mixed also depends importantly on the size and physical characteristics of the receptive region (including such factors as weather patterns, marine currents and tidal activity).
- Example: wastewater discharge in Victoria
^{no damage away from source due to huge tidal action in area}

Tangent: Non-Uniform Damage from Uniformly Mixed Pollutants

- Uniformly mixed pollutants do not necessarily cause the same degree of damage in ^{all} regions affected.
- Important example:
 - carbon-dioxide and the effects of climate change

Soil and Groundwater Contamination

- Associated with industrial sites where toxic waste materials have either been deliberately buried or dumped, or accidentally spilled.

Solid Waste

- A significant fraction of solid waste originates from industrial sources (the remainder originating from households).
- The main environmental impacts stem from transportation of waste to disposal sites, and from the disposal sites themselves.

Solid Waste

- In the case of incineration:
 - air pollution CO2!!!! transportation to disposal place
incineration pollution itself
- In the case of landfill disposal: Hartland landfill - used to be lake
 - methane gas emissions associated with organic material that rots in ground
can capture methane, and generate electricity
 - groundwater and soil contamination good landfills seals - impermeable layer between
landfill and ground
 - noxious fumes and land-use loss smells land taken, that could be used for another purpose

2.3-3 The Service Sector

- The service sector is typically less polluting than other sectors, since it is usually more knowledge intensive.
- Among the most important environmental impacts of this sector are those associated with transportation. [and energy use](#)

2.4 The Environmental Effects of Consumption

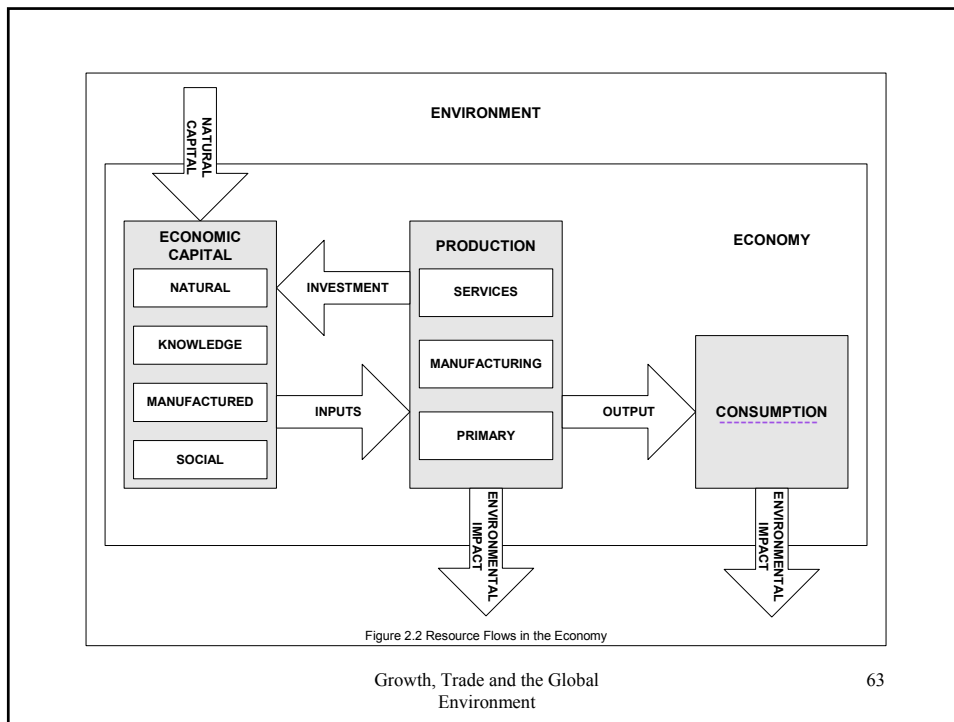

The Environmental Effects of Consumption

- Many of the polluting characteristics of consumption stem from properties of the products built into them at the production stage.
- Thus, in many instances environmental impacts associated with consumption are best addressed at the production stage.

ex - low sulphur fuel - sulphur can be extracted at production phase to eliminate effect in consumption

The Environmental Effects of Consumption

- The distinction between production effects and consumption effects is nonetheless useful, especially in a world with international trade because goods are often consumed in a country different from the one in which they are produced.

good produced in china, but consumed in canada.. address impact at consumption stage because we have no control over other countries and their production policies

Consumption-Related Environmental Impacts: Some Examples

- air pollution:
 - due to transportation and home energy use (for cooking, heating/cooling and lighting, etc.)
 - habitat disruption:
 - due to urbanization
- 2 biggest ones
- population grows into areas that were uninhabited

Consumption-Related Environmental Impacts: Some Examples

- solid waste:
 - a major problem in urban areas where land for landfilling is scarce and the effects of incineration pollution are concentrated
- water pollution:
 - due to wastewater, urban runoff, and chemical contamination from detergent use and household paint and solvent disposal

Consumption-Related Environmental Impacts: Some Examples

- Many of the most important impacts that households have on the environment are associated with energy use and urbanization.
- These issues are both discussed in detail in topics 3 and 7 respectively.

2.5 Uncertainty and Irreversibility

Uncertainty and Irreversibility

- Economic activity must by its very nature have an environmental impact. *all economic activity*
- The key to good policy is to ensure that the costs of that impact do not out-weigh the benefits associated with the economic activity that creates that impact.

activity worth the environmental cost

Uncertainty and Irreversibility

- This is a complex and difficult task made even more complicated by the fact that many environmental impacts are often unknown or of uncertain magnitude.

only 20% studied

Uncertainty and Irreversibility

- The importance of uncertainty about environmental impacts is magnified when coupled with *irreversibility*.
- An action is irreversible when it cannot be undone.

Uncertainty and Irreversibility

- Examples:
 - the extinction of a species
 - the build-up of atmospheric carbon dioxide
 - the release of genetically modified organisms into the wild

Uncertainty and Irreversibility

- Uncertainty and irreversibility mean that we need to be cautious in our approach to economic growth, especially when it comes to new activities with which we have little experience.
- Risk must play a prominent role in the calculation of costs and benefits.
irreversibility would not be a problem due to uncertainty it is

Uncertainty and Irreversibility

- However, concerns over risk can be taken to an extreme.
- In particular, some people argue that no activity should be undertaken unless its environmental impacts are fully understood. ^{"precautionary principle"}
- This is an unreasonably high standard to set.

Uncertainty and Irreversibility

- The natural system is so complex that we can never hope to fully understand how human activity affects the system in every respect. ^{cannot eliminate all risk}
- The natural dynamics of the system, and our integration into that system, mean that no course of action is neutral in terms of its impact on the current state of the system.

Uncertainty and Irreversibility

- But we cannot ignore risk.
- Efforts should be made to investigate the consequences of our actions before we undertake them.

Uncertainty and Irreversibility

- Our existing knowledge of system dynamics indicates that dramatic changes in our own activities – such as via very rapid economic growth – are likely to have more substantial repercussions for the natural system than more modest and gradual changes.

Uncertainty and Irreversibility

- The task for policy is to find an appropriate middle ground between unfettered growth with no regard for environmental risks and economic paralysis driven by an unrealistic requirement for absolute certainty.

End

3. Energy Use and the Environment

3.1 Introduction

Introduction

- Every aspect of production and consumption involves the use of energy.
- This chapter reviews some of the main issues with respect to energy use and its environmental impacts.

Introduction

- We begin with an overview of the energy system and then turn to the environmental impacts of energy use. *including climate change*
- We then consider possibilities for the future of the energy system.

3.2 The Energy System

tangent - THE LAWS OF THERMODYNAMICS

-what does it mean to "use" energy

-the 1st law of thermodynamics tells us that energy is not destroyed when we use it: it is simply transformed into another form

-so why is it not possible to keep using the same energy over and over again?

for example - WHEN WE BURN FOSSIL FUEL TO GENERATE HEAT, WE TRANSFORM THE energy stored in hydrocarbon molecules into heat and light - there is no loss of energy

-why can't we capture the heat and light

-----2nd law of thermodynamics

-system tend towards to maximum entropy (disorder)

- this heat and light from fossil fuel combustion dissipates into the wider universe

-cannot collect and re-use

-would have to use energy to recapture used energy

The Energy System

- The **energy system** refers to how the economy acquires and uses energy.
- The energy system comprises three parts:
 - primary energy sources
 - secondary energy (derived from primary energy)
 - energy services (which constitute the end uses of energy). *drives use of energy from economic perspective*

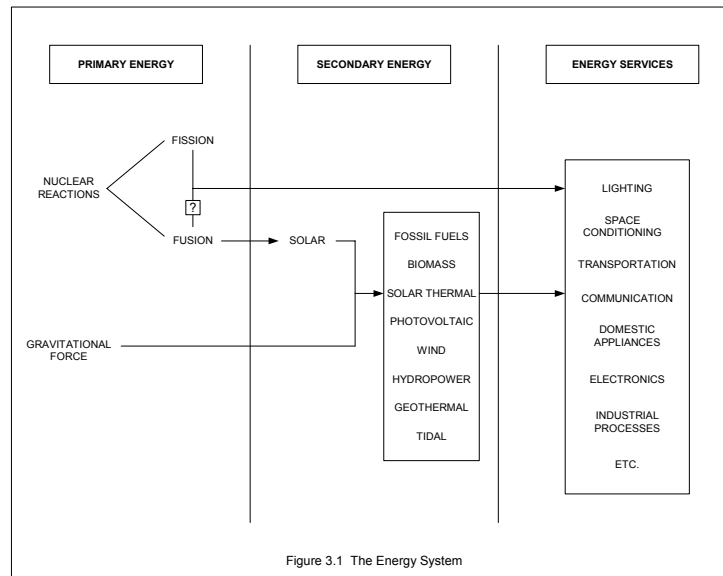

Figure 3.1 The Energy System

Primary Energy Sources

- There are only two primary energy sources:
 - gravitational force
 - the conversion of mass into energy via nuclear reactions.
- All secondary sources of energy are derived from these two primary energy sources.

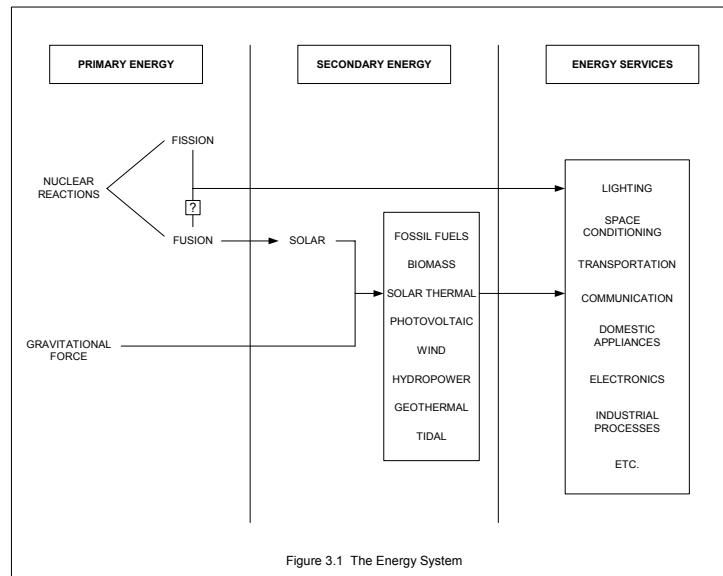

Figure 3.1 The Energy System

Primary Energy Sources

- **Gravitational force** drives tidal action and underlies the kinetic energy of falling water (used to generate electricity in hydroelectric projects).
- Gravitational forces during the formation of the planet – along with radioactive decay of elements like uranium – are also responsible for geothermal energy.

Primary Energy Sources

- **Nuclear reactions** – directly or indirectly – drive all of the other secondary energy sources.
conversion of mass into energy $E=mc^2$
- There are two types of nuclear reaction:
 - nuclear fission
 - nuclear fusion

no distinction between mass and energy

Primary Energy Sources

- *Nuclear fission* involves splitting the nuclei of heavy elements to form lighter elements.
- Existing nuclear power plants use the fission of uranium (the heaviest of the stable elements) to produce heat to steam drive turbines to produce electricity.
ALL to heat water

used for nuclear weapons as well

Primary Energy Sources

- *Nuclear fusion* involves fusing the nuclei of two lightweight atoms (like hydrogen) into a heavier one (like helium). destroy mass during this conversion
- There are currently no fusion reactors used to produce net energy on earth, due to technological obstacles. hydrogen bomb is fusion bomb

fusion creates vastly more energy compared to fission

fusion bombs vastly more powerful than fission bombs
however never used before

why no fusion reactors to produce energy? - difficult to contain reaction

Primary Energy Sources

- Experimental fusion reactors:
 - National Ignition Facility (California)
 - International Experimental Thermonuclear Reactor (France)
 - Max Planck Institute for Plasma Physics (Germany)

plans for 1 more

if can perfect fusion for electricity - will be good solution for energy needs

Primary Energy Sources

- The key role of nuclear fusion in the energy system today is via solar energy.
- The sun is a giant nuclear fusion reactor and all of the energy the earth captures from the sun derives from that primary source.
- Solar energy in turn powers most of the physical and biological processes that make up the natural system

Secondary Energy

- Most of our secondary energy sources are derived from solar energy.

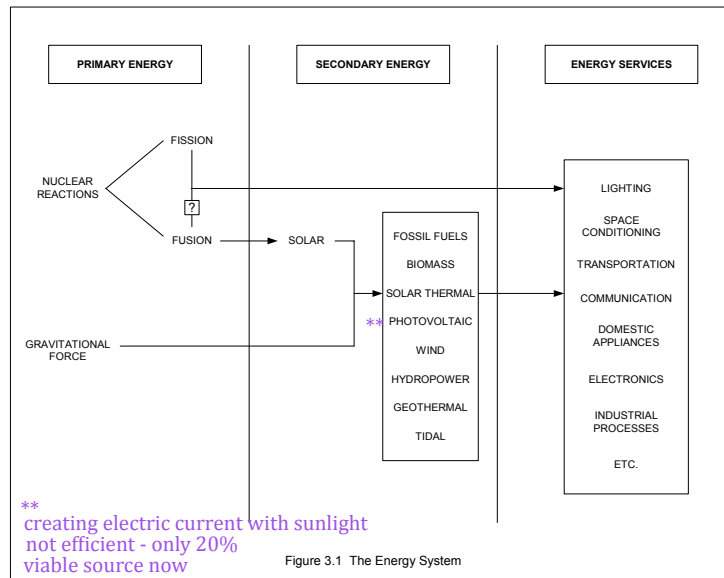

Growth, Trade and the Global Environment



tidal turbine

Growth, Trade and the Global Environment

do not like salt water
(obstacle)

Tangent: Geothermal vs. Geo-exchange

- Geothermal energy relates to heat from the core of the planet released to the surface.
- Geo-exchange relates to the differential heating and cooling of air and earth.

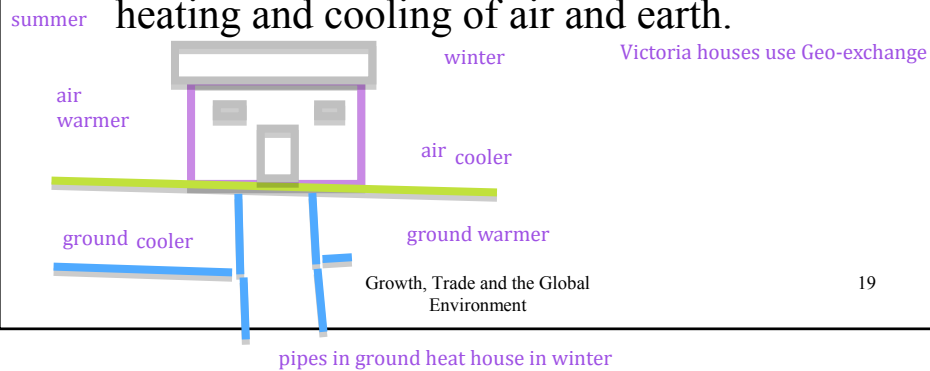

Energy Services

- Energy services are the services provided by energy in our production and consumption activities.

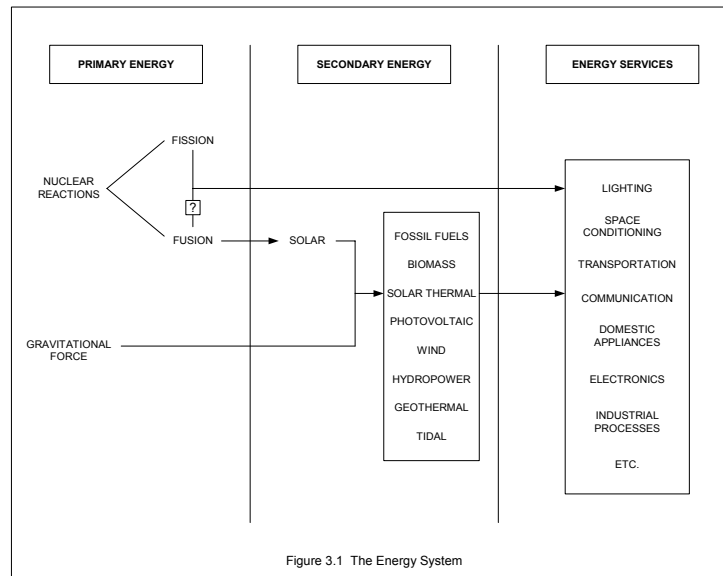

What about Hydrogen and Electricity?

- Hydrogen is not a source of energy.
- Hydrogen can be an effective means of storing and transporting energy – to be used in fuel cells or burned directly (with water as the only by-product) – but it is neither a primary nor secondary energy source.

nuclear reaction using hydrogen can be source of energy

What about Hydrogen and Electricity?

- Energy must be used to extract hydrogen either from water (by electrolysis) or from hydrocarbons (such as natural gas).

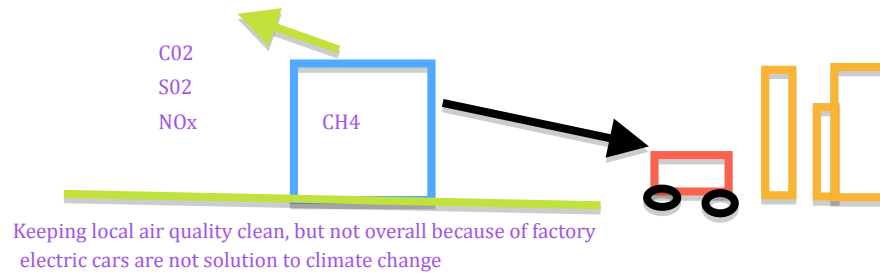

Growth, Trade and the Global
Environment

23

What about Hydrogen and Electricity?

- Electricity is not a source of energy either.
- It is a convenient means of packaging and transporting energy but it must be produced from a primary or secondary source.

Growth, Trade and the Global
Environment

24

Tangent: Technology and Access to Oil

- The Pre-sal Oil Fields (Brazil)

The Pre-sal Oil Fields (Brazil)

difficult to get to



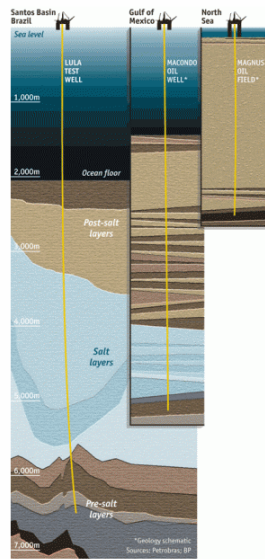

Growth, Trade and the Global Environment

3.3 The Environmental Impacts of Energy Use

The Environmental Impacts of Energy Use

- All energy use has environmental impacts regardless of the source.
- Impacts vary widely depending on the energy source - and some impacts are usually deemed to be less harmful than others - but there is no such thing as truly environmentally neutral energy use.

cleaner vs dirtier
no 'clean' energy

Growth, Trade and the Global
Environment

29

Fossil Fuels and Other Carbon-Based Fuels

- Atmospheric particulates busses are terrible for particulates
 - cause of respiratory illness
 - main sources: diesel fuel, coal and wood (especially in developing countries)
 - source of global *cooling* due to the reflection of sunlight offset global warming of CO2 with particulates, but not much

Growth, Trade and the Global
Environment

30

Fossil Fuels and Other Carbon-Based Fuels

- Carbon dioxide
 - the single most important contributor to anthropogenic climate change
 - source: any carbon-based fuel

Fossil Fuels and Other Carbon-Based Fuels

- Sulfur dioxide and nitrous oxides *impurities*
 - acidification of precipitation (which causes damage to aquatic ecosystems, forests, crops, buildings and other materials)
 - nitrous oxides also act as catalysts in the formation of *tropospheric ozone* (causes eye and respiratory irritation, and damage to forests, crops and materials)

Fossil Fuels and Other Carbon-Based Fuels

- sulfur dioxide is also believed to be a source of global cooling
- Volatile organic compounds (VOCs)
 - released during the transportation, transfer and combustion of petroleum products and natural gas
 - known carcinogens and catalysts in the formation of tropospheric ozone

Nuclear Power

do not create CO₂

- Three most important environmental risks:
 - the short-term and long-term storage of highly radioactive spent fuel
 - the disposal of contaminated coolants and other materials after reactor decommissioning
 - reactor core breach accidents (such as the 1986 accident at Chernobyl in Ukraine and the 2011 accident at Fukushima, Japan)

reactors last 30 years

Nuclear Power

- Primary danger is exposure to radioactivity
 - known to cause illness and death
 - long-term genetic damage even in small exposure doses

cancers

Hydroelectric Generation

- Large scale flooding that usually accompanies hydroelectric generation has some significant environmental impacts
 - deforestation see notes
 - foregone land use
 - habitat loss (for fish and wildlife)
 - mercury contamination associated with leaching from flooded soils and rocks

alternative to usual suspects - fossil fuels/nuclear/

Alternative Energy Sources

- Often hailed as environmentally clean; somewhat misleading.
- Producing electricity on a large scale using wind turbines would require the devotion of vast amounts of land to “wind farms”
noisy/not attractive
./kill birds/use land
- Similar land use requirements would arise from large scale biomass fuel production or large scale arrays of photovoltaic cells.

wind
intermittent

Growth, Trade and the Global Environment

37

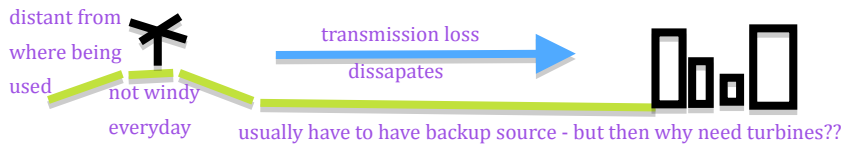

Alternative Energy Sources

- Nonetheless likely to become more important in the future – at least as transition fuels until more viable solutions are found (see section 3.5)

there are environmental impacts from 'clean sources'

Growth, Trade and the Global Environment

38

3.4 Climate Change

more people die from particulates than from climate change

Climate Change

- There are six main greenhouse gases (GHGs) but the most important in terms of overall impact – and the one most closely related to energy use – is carbon-dioxide.

Climate Change

burning fossil fuels builds
CO₂

- Carbon dioxide concentrations in the atmosphere have risen from around 280 parts per million (ppm) during the mid 1700s to around 380ppm today.
- Ice core samples indicate that concentrations have not been that high for over 500,000 years. why were CO₂ so high in past?

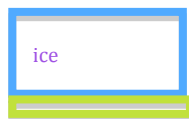

Growth, Trade and the Global
Environment

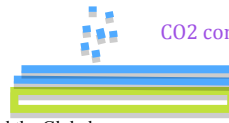

41

Climate Change

- At projected emission rates – along a “business-as-usual” path – atmospheric concentrations will reach 800ppm by 2100.
- Most climate models indicate that this will cause substantial long run warming of the planet.

Growth, Trade and the Global
Environment

42

3.4-1 Stock versus Flow

- Climate change is associated with the *stock* of accumulated carbon-dioxide in the atmosphere.
- Even if the flow of emissions was reduced to zero tomorrow, the stock of atmospheric carbon dioxide would persist, returning to pre-industrial levels only after several centuries.

Stock versus Flow

SEE NOTES

- Climate change due to atmospheric carbon-dioxide is believed to occur with very long lags, due to inertia in the natural system.
- The effects of the existing elevated stock will not be felt for another 50 – 100 years.

C02 emissions today, will affect in 50 years.
we are affected by C02 emissions from 50 years ago

Stock versus Flow

- These properties of the climate change process have two key implications for policy design:
 - cutting emissions today will not yield benefits until many years into the future
 - some climate change will inevitably occur over the coming century due to the elevated stock of carbon dioxide over the *past* century

technology advances, may be able to deal with climate change caused by past generations

no matter what we do, some climate change is coming

do we put resources into finding solutions for climate change, or into reducing the impact of the inevitable climate change?

Stock versus Flow

- These two implications raise important policy questions:
 - what is the appropriate mix of abatement versus defense (or adaptation)?
 - how do we deal with the intergenerational distribution of costs and benefits of climate policy?

Can we Reduce the Existing Stock?

- Can we take measures to actively reduce the existing stock (in addition to measures to reduce the flow of emissions)?
 - permanent afforestation
 - seeding the oceans with iron
produce algae and will extract CO2 from atmosphere
- Prospects are not good; some climate change now seems inevitable.
not sure of consequences from putting iron into ocean - it is irreversible

3.4-2 Potential Impacts of Climate Change

- The impacts of climate change are uncertain.
- A variety of climate models have produced various scenarios ranging from mild warming to dramatic temperature increases coupled with catastrophic sea level changes and an increased incidence of severe weather events.

Potential Impacts of Climate Change

- The uncertainty reflects an incomplete understanding of the complex dynamic processes that govern the terrestrial and oceanic carbon cycles and how they interact with the climate.

Likely Impacts

- Impacts expected even under relatively optimistic scenarios:
 - an overall warming but with possible exceptions in which some regions become cooler
 - changes in local weather patterns and a likely increase in the variance within those patterns (leading to less predictable weather)

farmers want predictable weather

Likely Impacts

- an increase in storm intensities from increase in temp in water
- changes in the distribution of wild plants and animals (including pests) and changes in the growing conditions for agricultural crops not being killed off in winters
- a rise in sea levels due to thermal expansion of water

now here can grow same crops due to temp increase

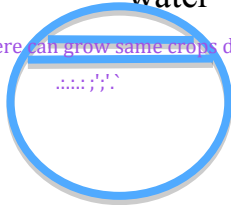

Likely Impacts

- Some of these changes could be positive in some cases, if they occur gradually enough to allow adaptation.
- For example
 - a warming of the Canadian and Russian climates could allow extended growing seasons over expanded northern ranges
 - lower heating costs in Canada

Likely Impacts

- Other changes – such as sea level rises and diminished predictability of weather – are likely to be very harmful.
- On balance, most studies indicate that the overall impact on the global economy will be negative, even under optimistic climate change scenarios.

Unlikely but High Cost Scenarios

- There are three main sources of concern with respect to the possibility of dramatic and highly damaging climatic changes:
 - ice sheet melt
 - Gulf Stream shutdown
 - self-reinforcing feedback loops

Ice Sheet Melt

- Melting of *sea ice* does not have a large impact on sea levels because the buoyancy of the floating ice currently displaces sea water.
- The ice sheets that cover Greenland and Antarctica are sitting on land. *danger!*
- If these ice sheets melt completely then sea levels would rise by around 90 meters.

Gulf Stream Shutdown

- The Gulf Stream is part of an oceanic cycle known as the North Atlantic Gyre.
- The cycle operates as follows:
 - rotation of the earth creates a circulation of water in the subtropics which brings warm salty water north from the equator
 - that warm water sinks as it moves north where it meets less salty water, which is less dense

Gulf Stream Shutdown

- northern water is less salty because there is less heat from the sun and hence, less evaporation

- as the warm water sinks it drags more warm water north and displaces colder water which flows south along the east coast of North America.

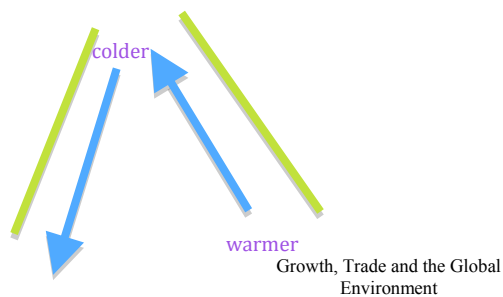

57

Gulf Stream Shutdown

- This process brings relatively warm water along the west coast of northern Europe creating a climate in western Europe that is far warmer than it would otherwise be.
- Example:
 - London has a latitude of 51.30 degrees
 - St. John's has a latitude of only 47.34 degrees

Growth, Trade and the Global Environment

58

Gulf Stream Shutdown

- If there is significant ice melt – whether from sea ice or ice sheets – the dilution of the salty north-flowing water could diminish (and potentially shutdown) the Gulf Stream.
- The climate of north-western Europe would then become much colder.

- could make east coast of north america warmer

Self-Reinforcing Feedback Loops

- There is a possibility that global warming will set-off self-reinforcing processes that will exacerbate the warming trend.
- Examples:

– reduced *albedo*

– release of methane and carbon dioxide due to warmer ocean water and thawing of permafrost
frozen soil houses methane, and CO2

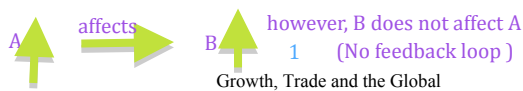

given A affecting B, if:

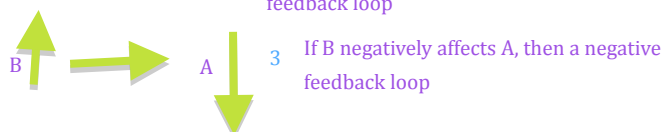

Self-Reinforcing Feedback Loops

- These feedback loops could potentially set the planet on a path of self-reinforcing runaway warming.
- This possibility leads to some of the most catastrophic climate change scenarios.

RUNAWAY GLOBAL WARMING - no stopping it when it gets to a certain level

Tangent: NRTEE Report (Sept 2011)

- National Roundtable on the Environment and the Economy (NRTEE); now defunct.
- “Paying the Price: the Economic Impacts of Climate Change for Canada”; available on the course website.
 - 2020: \$5 billion per year
 - 2050: Between \$21 and \$43 billion per year

3.4-4 Canada and Climate Change

- What is the optimal action for Canada?
 - A mix of defensive action (adaptation) and emissions reductions but the latter only as part of a multilateral global treaty.
- Unilateral emission reductions will yield almost no benefits and will involve huge costs.
- Why? Canada is a small player (1.5%).

Growth, Trade and the Global Environment

63

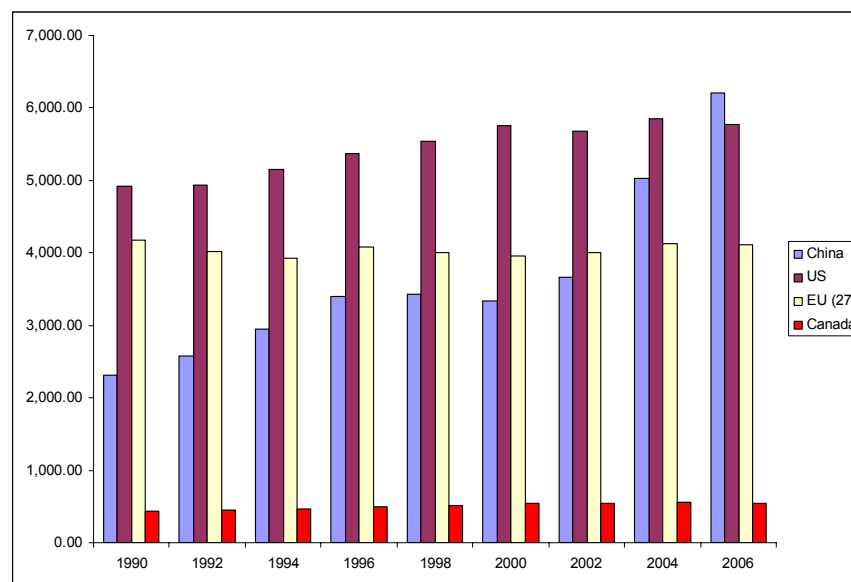

Growth, Trade and the Global Environment

64

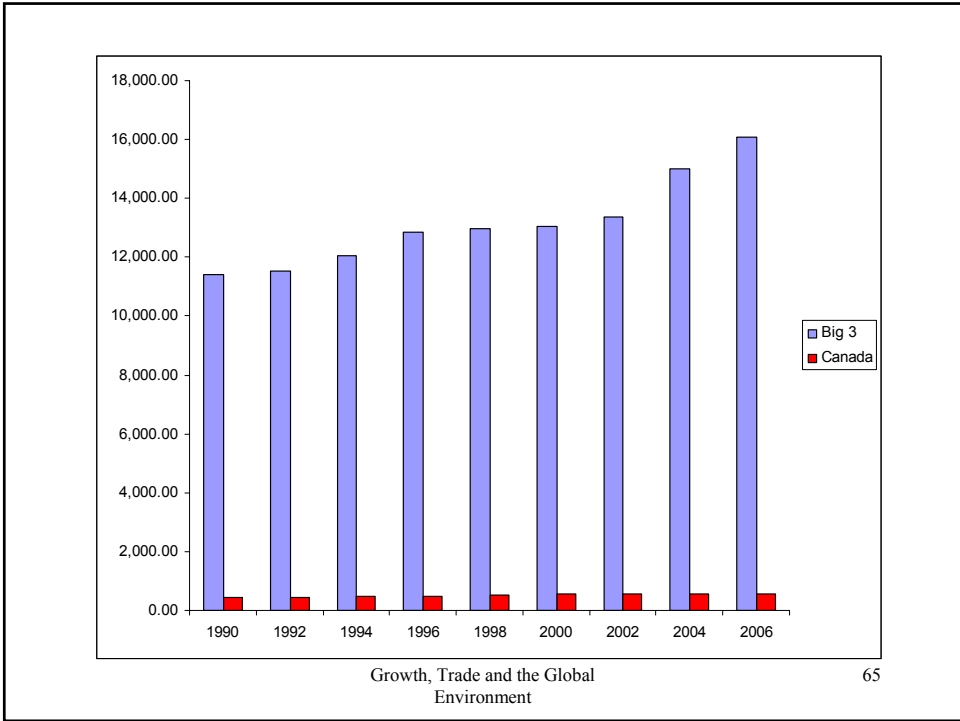

65

Tangent: Per Capita Emissions

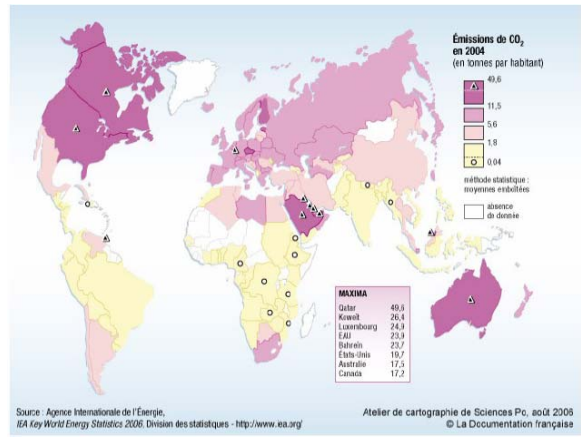

Growth, Trade and the Global Environment

66



Growth, Trade and the Global Environment

67

Are per capita emissions relevant?

- Key points:
 - a tonne of emissions causes the same damage regardless of which country emits it
 - large emitters have jurisdictional control of a larger volume of emissions
 - population is a choice variable
 - an equitable global agreement should be based on per capita wealth (a disputed view)

Growth, Trade and the Global Environment

68

Copenhagen 2009 “Commitments”

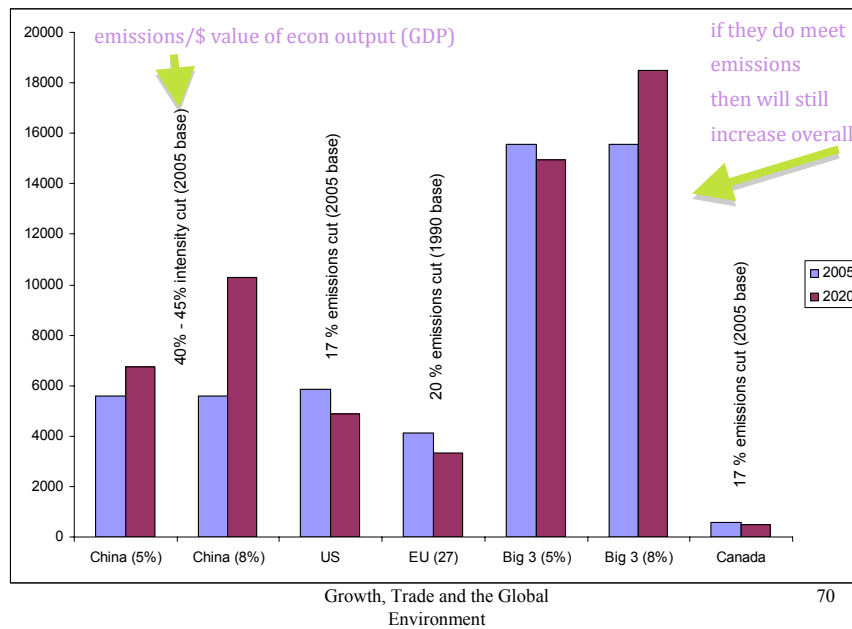

More Likely (Non-Cooperative) Outcome

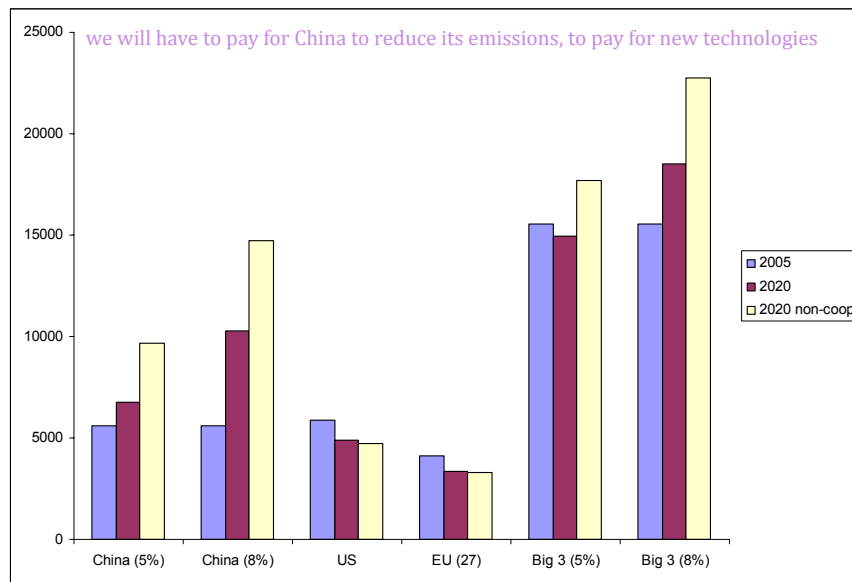

Growth, Trade and the Global Environment

72

3.4-3 The Distribution of Impacts

- The impacts of climate change will likely be felt most strongly by the people of the poorest countries, for two reasons:
 - these countries tend to rely more heavily on agriculture than richer countries
we rely 8% on agriculture here in Canada
 - these countries have fewer resources available to defend against climate change and adapt to it
we have resources to defend against it - seawalls, research to better our crops

3.5 The Energy Future

The Energy Future

- How will future energy demand be met without large scale environmental damage?
- Four potential answers:
 - improved energy efficiency
 - “renewable” energy sources
 - nuclear power
 - fossil fuels with geosequestration

Energy Efficiency

- The energy intensity of economic activity – measured as megajoules of energy per dollar of gross domestic product – has fallen more-or-less steadily over the past century.
- This reflects a substitution of knowledge for natural capital.

Energy Efficiency

- The scope for additional gains in energy efficiency are substantial.
- The key to extracting those gains is to create the right incentives, by letting prices reflect the true cost of energy use, including the cost of associated environmental damage.

Energy Efficiency

- However, energy-efficiency is *not* a source of energy; it cannot provide an answer to the fundamental question of long run energy supply.

“Renewable” Energy Sources

- Some scope for increased reliance on alternative energy sources:
 - small-scale hydroelectric
 - biomass
 - wind
 - solar
 - tidal
 - geothermal

“Renewable” Energy Sources

- Even the most optimistic forecasts for technological advances paint a future in which renewables continue to play only a modest role.

Nuclear Fission

- Politically unpopular and there are still many technological issues that need to be resolved with respect to the safe storage of radioactive waste.
- However, nuclear power is currently the only viable alternative to fossil fuels for large scale energy supply.

Fossil Fuels with Geosequestration

- Coal and “unconventional” oil and gas – from tar sands, shale-bed gas and methane hydrates on the sea floor – constitute a vast supply of energy sources that is still relatively untouched.
- Coal reserves alone could satisfy energy demand for the next 150 –200 years.

Fossil Fuels with Geosequestration

- What about the carbon dioxide?
- Geosequestration (carbon capture and storage):
 - carbon-dioxide is captured at source when the fuel is burned and then transported by pipeline to a site where it is pumped underground

Fossil Fuels with Geosequestration

- Existing pilot projects demonstrate that geosequestration at source is feasible and not prohibitively costly.
- There are some safety concerns such as the possibility of accidental release.

The Bottom Line

- The bottom line on the energy future:
 - there are no easy risk-free solutions.
- The only serious contenders for reliable large scale energy supply on the current horizon are nuclear fission and fossil fuels coupled with geosequestration.

The Bottom Line

- The development of nuclear fusion reactors would provide the ultimate answer.

End

4. Trade Liberalization and Multilateralism

4.1 Introduction

Introduction

- Trade and investment flows between countries - together with transboundary environmental impacts - create a web of international linkages between national economies and national environments.

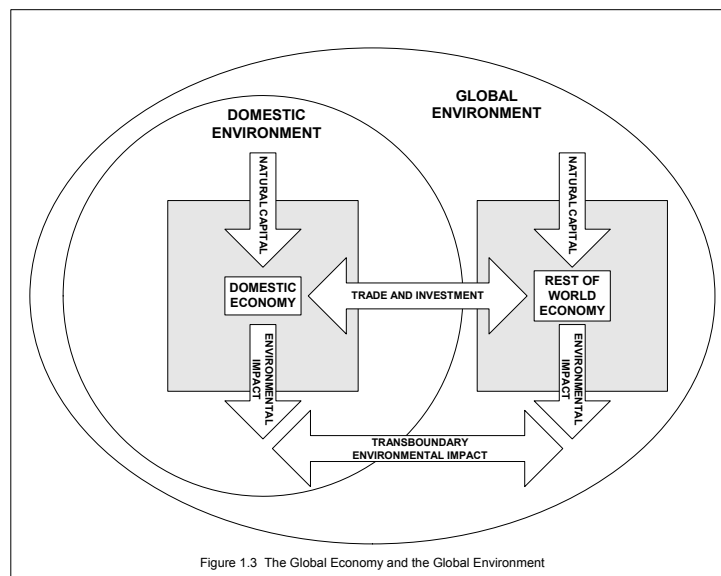

Figure 1.3 The Global Economy and the Global Environment

Introduction

- In this chapter we focus on international trade and investment.
- We begin with a basic discussion of how international trade and investment alters the flow of resources within a national economy.
- We then discuss the potential costs and benefits of trade liberalization.

Growth, Trade and the Global
Environment

5

4.2 International Trade and Investment Flows

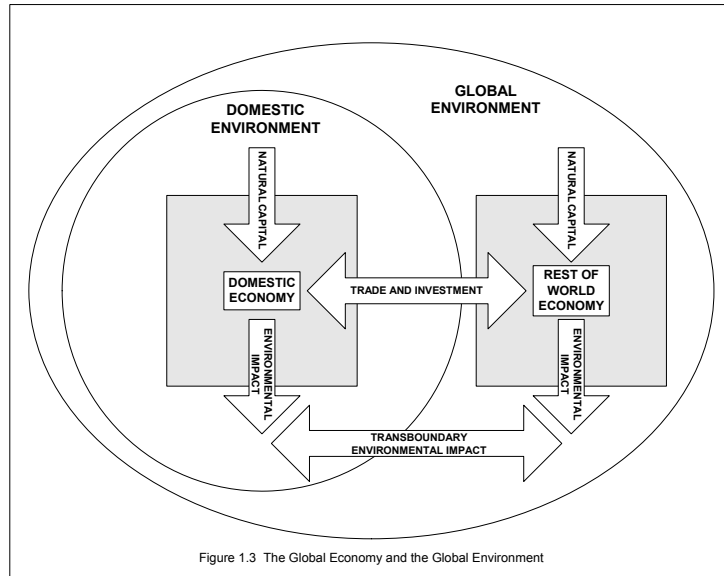

Figure 1.3 The Global Economy and the Global Environment

Growth, Trade and the Global Environment

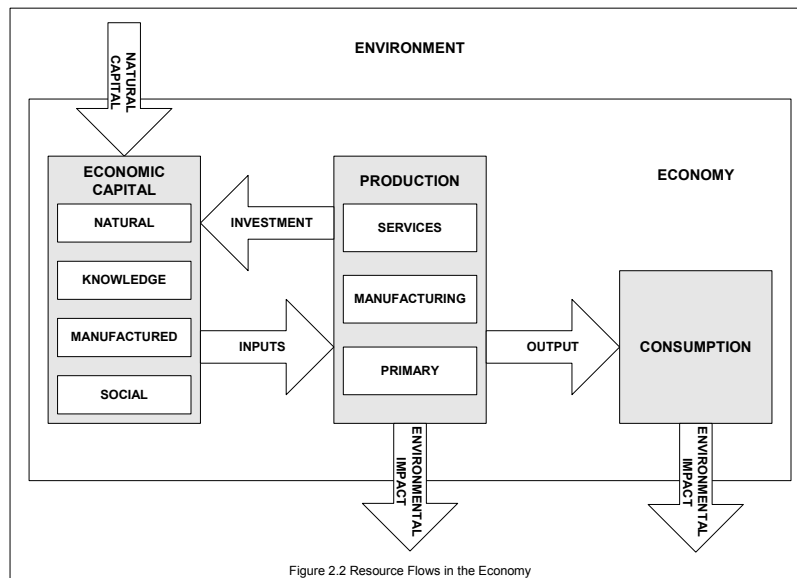

Figure 2.2 Resource Flows in the Economy

Growth, Trade and the Global Environment

International Trade and Investment Flows

- There are two key components to international trade and investment flows:
 - international investment
 - exports and imports

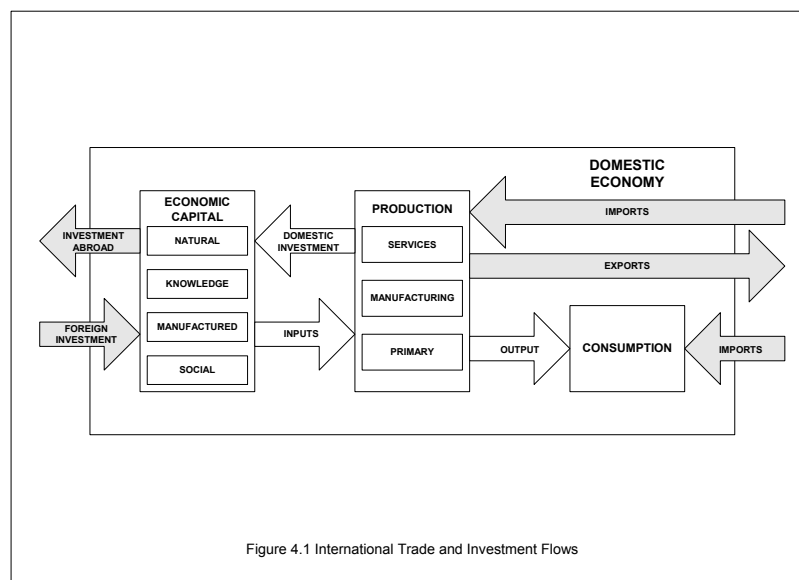
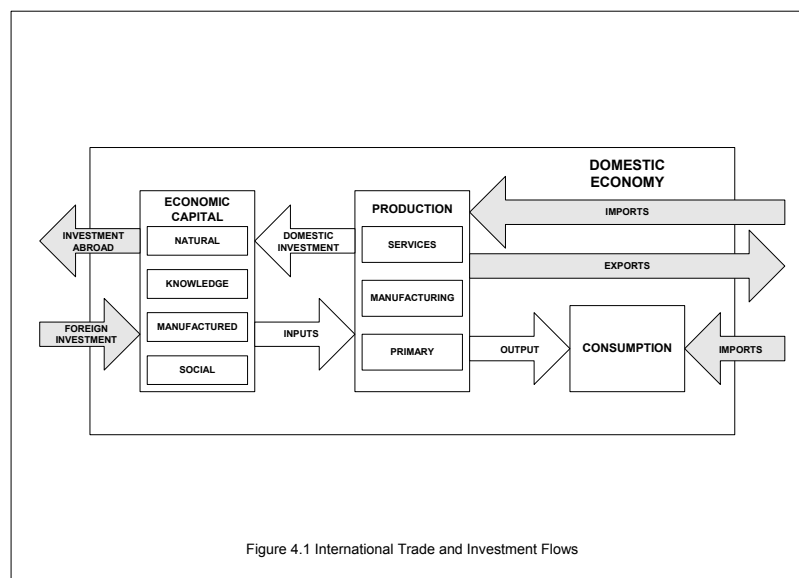

Figure 4.1 International Trade and Investment Flows

International Investment

- International investment refers to the flow of economic capital between countries.
- *Foreign investment* represents the augmentation of the domestic stock of economic capital from foreign countries.



International Investment

- *Investment abroad* is simply the reverse of foreign investment: the augmentation of foreign economic capital with resources from the domestic country.

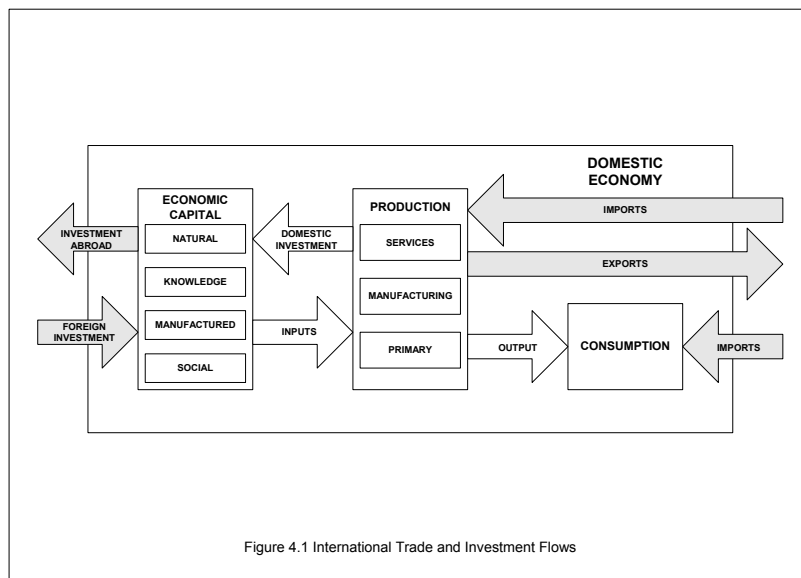

International Investment

- International investment may be
 - *indirect*, where financial investment by foreigners in domestic firms provides the funding (and knowledge) for the physical investment; or
 - *direct*, where foreign firms construct plant and equipment in the host country.

International Investment

- Transfers in knowledge are often called “technology transfers”, but it is important to distinguish between the transfer of physical equipment that embodies knowledge, and the transfer of knowledge *per se*.

International Investment

- The transfer of knowledge may be intentional or it may constitute an unintentional “spillover”.
- For example:
 - “reverse engineering” of imported equipment refers to the process of dismantling that equipment in order to learn how it works and how it is built.

International Investment

- The associated transfer of knowledge is a spillover from the transfer of the physical equipment.
- Such spillovers can actually constitute a barrier to the transfer of knowledge across countries.
 - Intellectual property rights are important for facilitating investment.

International Investment

- International investment also has an important role to play in the augmentation of social capital.
- Examples:
 - institutional structures
 - policy design knowledge

Exports and Imports

- Exports and imports refer to the transfer of goods and services between countries.

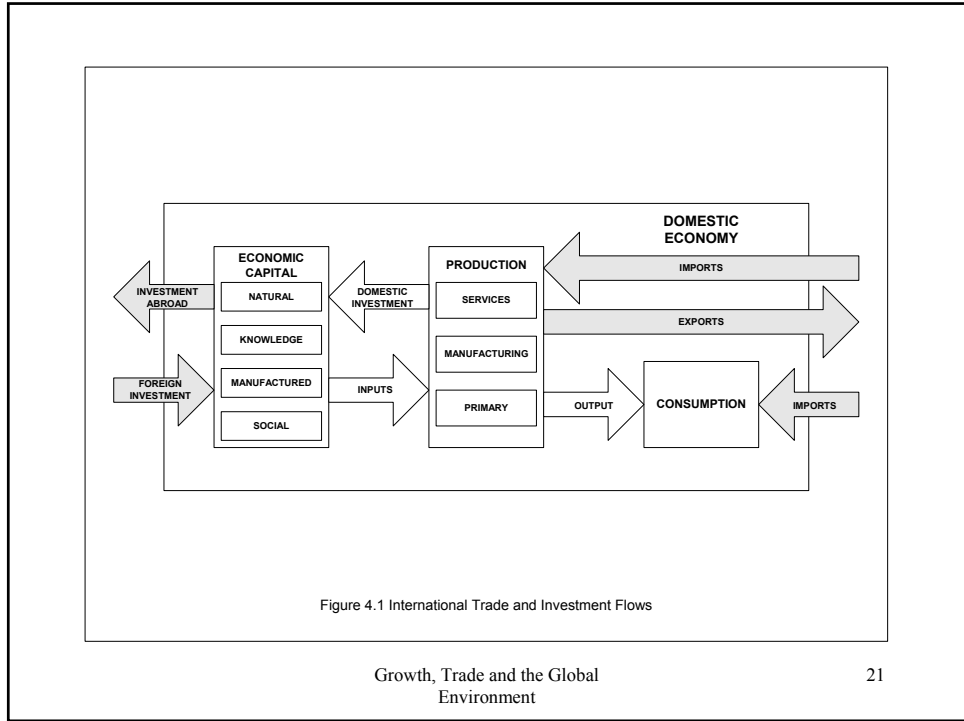

Exports and Imports

- The flow of goods between countries causes a geographical and jurisdictional separation between production and consumption.
- The direct link between natural capital utilization and environmental impact that holds at the global environment level need not hold at the level of individual country environments.

4.3 The Benefits and Costs of Trade Liberalization

The Benefits and Costs of Trade Liberalization

- Trade liberalization and multilateralism can be a positive force for sustainable development if policies are designed properly to capture the full benefits of trade and limit its potential costs.

4.3-1 Gains from Trade

- Trade is good:
 - trade allows the cooperative exchange of ideas, goods and services to the mutual benefit of both partners in the trade
- Two parts to our discussion:
 - the basis for trade
 - the benefits of trade

The Basis for Trade

- The main basis for trade is *heterogeneity* across trading partners with respect to economic capital.
- Two basic sources of heterogeneity:
 - historical differences in natural capital endowments
 - economies of scale and scope in production

Historical Differences in Natural Capital Endowments

- Most early trade reflected simple differences in climate and soil conditions across countries.
- Modern trade in raw materials still derives principally from differences in natural resource stocks.

Historical Differences in Natural Capital Endowments

- Over time, differences in natural capital endowments gradually induced differences in the development of other forms of economic capital.

Historical Differences in Natural Capital Endowments

- Those differences in economic capital became magnified over time as initially small degrees of divergence in the evolution of economic capital precipitated progressively larger degrees of divergence.

Historical Differences in Natural Capital Endowments

- Trade itself was a key factor in that divergence across countries:
 - *specialization* in production according to *comparative advantage*, based on economic capital differences, reinforced those differences over time

Tangent: Guns, Germs, and Steel

- Recommended reading:
 - Jared Diamond (1999), “Guns, Germs, and Steel: The Fates of Human Societies”

Economies of Scale and Scope

- “Economies of scale”:
 - unit production costs fall as the level of production increases

Economies of Scale and Scope

- Economies of scale derive from
 - the existence of fixed costs (including expenditures on research and development)
 - the physical characteristics of production processes (such as the more-than-proportionate relationship between the surface area and capacity of a cylindrical tank).
 - learning-by-doing over time

Economies of Scale and Scope

- “Economies of scope”:
 - the unit production cost of one product is lower if another product is produced in conjunction with it.
- Example:
 - economies of scope in the production of gasoline and jet fuel because they can both be produced using the same refining process.

Economies of Scale and Scope

- Why are economies of scale and scope important for trade?
- Two reasons:
 - they amplify and maintain the cross-country divergence in the historical evolution of economic capital
 - imperfect competition

Amplification and Maintenance of Cross-Country Differences

- Example:
 - development of steam engine in Britain gave that country a *technological leadership* advantage through learning-by-doing.
- The first-mover advantage can persist because economies of scale and scope create *barriers to entry* (cost advantages over would-be competitors).

Imperfect Competition

- The barriers to entry associated with economies of scale and scope can lead to *imperfect competition* in production:
 - production tends to be dominated by a small number of large firms.
- Much of the current global trade in industrial products comprises cross-country sales by large multinational corporations.

The Benefits of Trade

- The benefits of trade stem from four main sources:
 - the direct exchange of economic capital
 - specialization in production
 - the exploitation of economies of scale and scope
 - competitive pressure

Direct Exchange of Economic Capital

- Production usually requires a mix of capital types.
- Thus, a country with a relative abundance of one type of economic capital can benefit from an exchange with another country possessing a relative abundance of a different type.

The Benefits of Trade

- The benefits of trade stem from four main sources:
 - the direct exchange of economic capital
 - [specialization in production](#)
 - the exploitation of economies of scale and scope
 - competitive pressure

Specialization in Production

- The direct exchange of economic capital can often be prohibitively costly.
- An alternative way for two countries to effectively share their economic capital is to do so indirectly, through the exchange of produced goods.

Specialization in Production

- Each country can *specialize* in the production of goods to which its economic capital is best suited.
- Both countries benefit from the effective sharing of economic capital.

Appendix: Comparative Advantage and Specialization

	COUNTRY A	COUNTRY B
GOOD 1	12	4
GOOD 2	6	12

Table 4.1 Labour Productivity

Growth, Trade and the Global
Environment

43

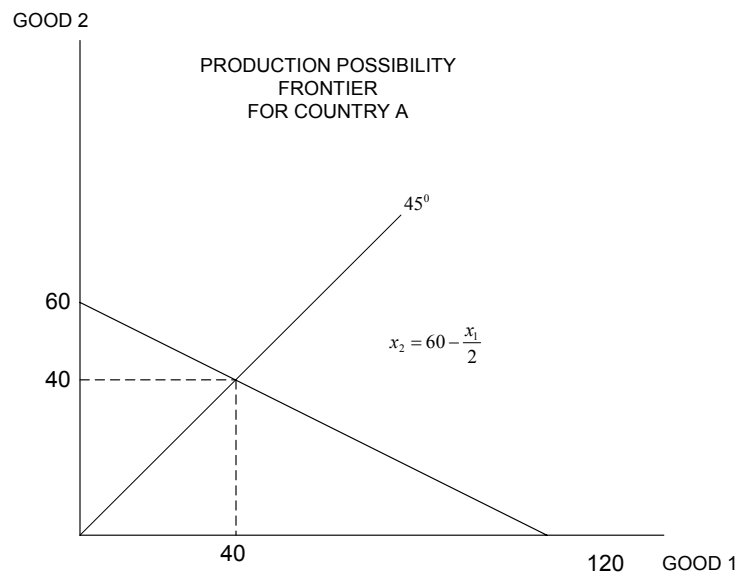

Growth, Trade and the Global
Environment

44

	COUNTRY A	COUNTRY B
GOOD 1	12	4
GOOD 2	6	12

Table 4.1 Labour Productivity

Growth, Trade and the Global Environment

45

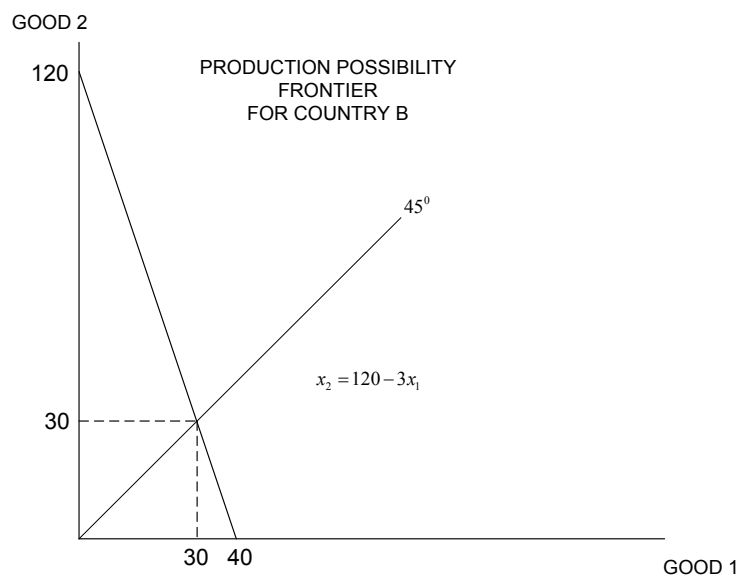

Growth, Trade and the Global Environment

46

Comparative Advantage and Specialization

- Total production without trade:
 - Good 1: 70 units
 - Good 2: 70 units
- Total production with specialization:
 - Good 1: 120 units
 - Good 2: 120 units

only trade, if in your interest, = most units from trading, then from not trading

Comparative Advantage and Specialization

- The division of goods is determined by bargaining (or competitive markets)
- Example:
 - equal sharing (60 units of each good)
- Trade cannot make either country worse off or else they would not trade.

Comparative Advantage and Specialization

- **Complications:**
 - non-linear PPFs
 - differences in preferences
 - uncertainty and irreversibility means that some diversity in production should be retained.

The Benefits of Trade

- The benefits of trade stem from four main sources:
 - the direct exchange of economic capital
 - specialization in production
 - the exploitation of economies of scale and scope
 - competitive pressure

Exploitation of Economies of Scale and Scope

- By selling to a large global market firms are more able to produce at volumes where unit costs are lower than if they were producing solely for a small domestic market.
- This means that fewer resources are required to achieve a given level of production.

The Benefits of Trade

- The benefits of trade stem from four main sources:
 - the direct exchange of economic capital
 - specialization in production
 - the exploitation of economies of scale and scope
 - competitive pressure

Competitive Pressure

- Industry concentration can lead to overpricing and under-production relative to what social costs and benefits dictate.
- Trade allows the pressure of *foreign competition* to moderate these distortions.
- The competitive pressure can also serve to foster innovation.

The Benefits of Trade

- The benefits of trade stem from four main sources:
 - the direct exchange of economic capital
 - specialization in production
 - the exploitation of economies of scale and scope
 - competitive pressure

4.3-2 The Costs of Trade Liberalization

- Two main sources of costs that can accompany trade liberalization:
 - structural adjustment (see Chapter 6 for detail)
 - strategic distortion of policy (see Chapter 8 for detail)

Structural Adjustment

- Structural adjustment:
 - the substitution and displacement that accompanies the shifts in consumption and production patterns associated with trade liberalization.
- A role for policy to manage adjustment and ensure that the costs of the adjustment do not fall too heavily on any single group.

Strategic Distortion of Policy

- Strategic distortion linked to industry concentration and the associated existence of *rents* (above-normal profits) to imperfectly competitive firms.
- Incentive to distort domestic policies in order to boost the global market share of the firms based there, and thereby capture a greater share of the associated rents.

Growth, Trade and the Global
Environment

57

4.4 Coordination vs. Uniformity in Multilateral Agreements

Coordination vs. Uniformity

- Multilateral agreements, and related international treaties and conventions, provide a mechanism for the *coordination* of standards and policies of all signatory countries.
- This international coordination is one of the most positive aspects of globalization.

Coordination vs. Uniformity

- The coordination of different standards and policies does not require that those standards and policies be the same across countries.
- Multilateral agreements should allow different countries to establish different standards and set different policies according to their specific characteristics.

Coordination vs. Uniformity

- The key to successful multilateralism is cooperation and coordination, not uniformity.

4.5 Trade Liberalization and Sustainable Development

Trade Liberalization and Sustainable Development

- Trade liberalization has both benefits and costs.
- On balance, the benefits will outweigh the costs under most circumstances, but good policy is needed to ensure that.
- This need for good policy design is particularly true with respect to the environment.

Trade Liberalization and Sustainable Development

- The rest of the course focuses on the details of the links between trade and the environment, and on the design of appropriate policies for the marriage of trade liberalization and sustainable development.

End

5. Scale, Technique and Composition Effects of Trade on the Environment

5.1 Introduction

Introduction

- Trade liberalization can have a dramatic effect on the volume and composition of resource flows through the economy.
- These changes can in turn have a significant impact on environmental quality.
- Our purpose in this chapter is to examine the key channels through which that impact occurs.

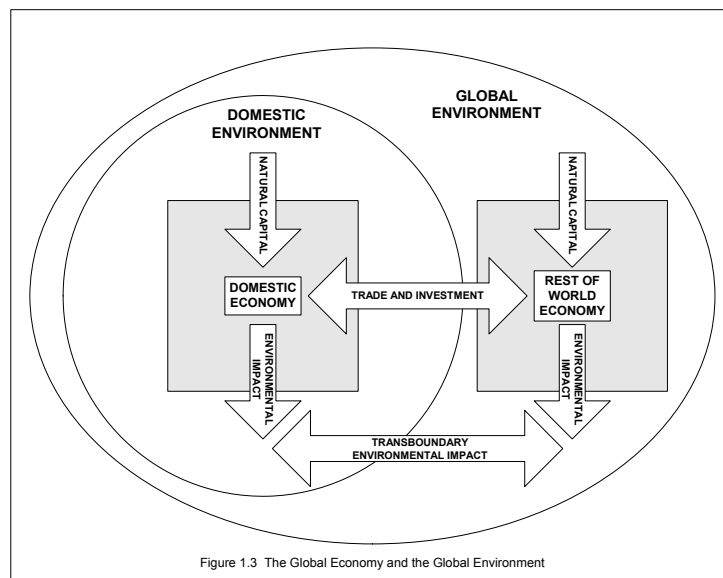

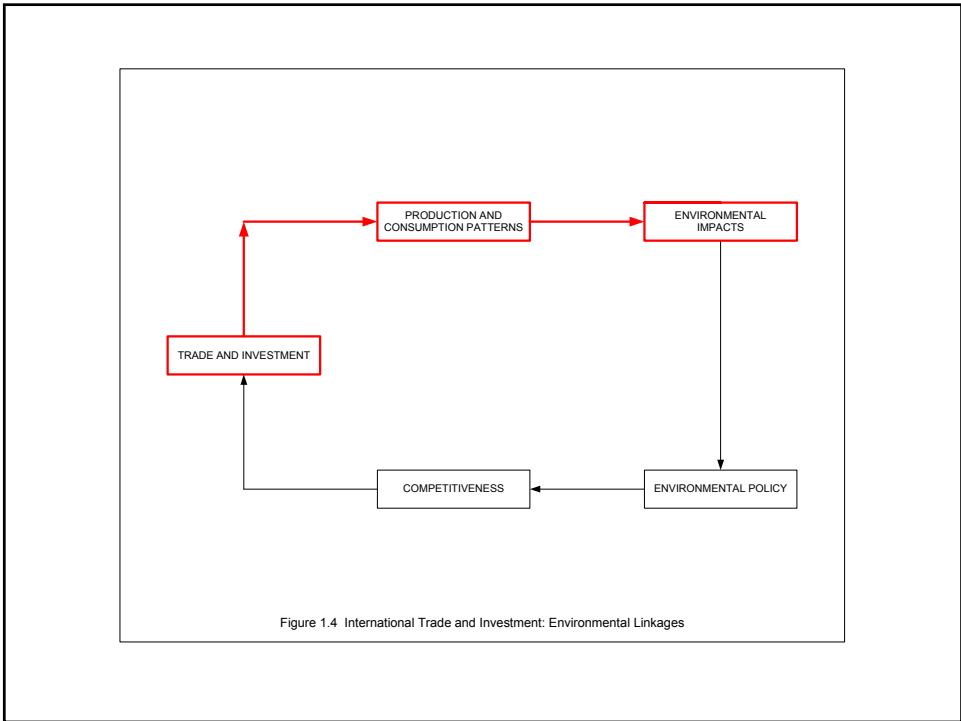
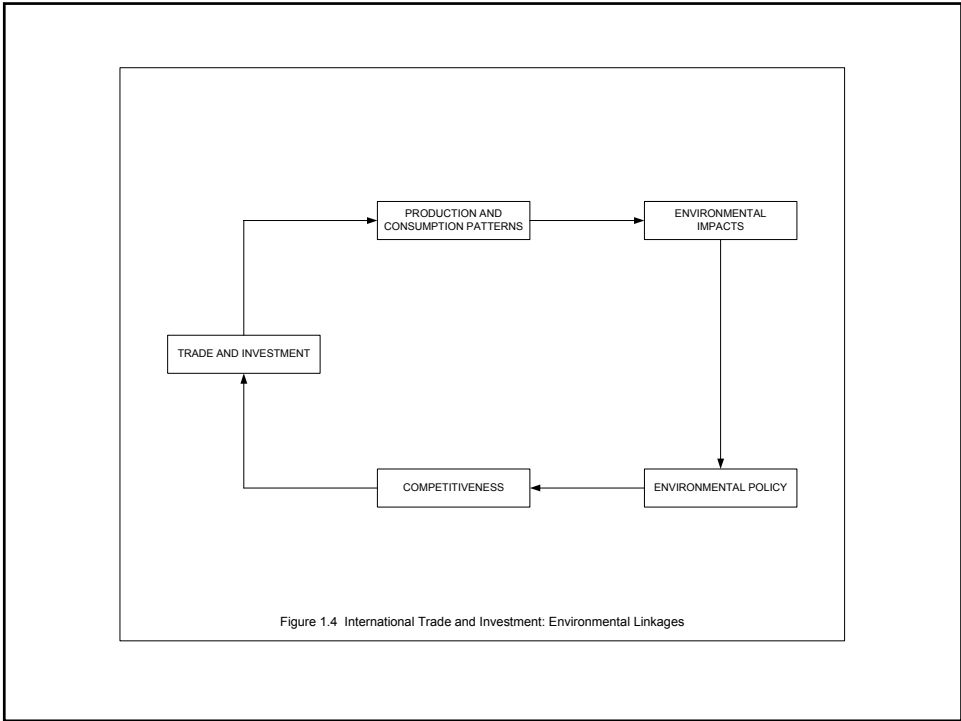

Introduction

- There are three such channels:
 - a scale effect
 - a technique effect
 - a composition effect

5.2 The Scale Effect of Trade

The Scale Effect of Trade

- Trade has the potential to benefit all parties involved by exploiting
 - comparative advantage due to differences between countries in the composition of economic capital stocks
 - economies of scale and scope

The Scale Effect of Trade

- That benefit arises as increased production and consumption.
- *All other things equal*, this typically translates into an increased throughput of material and a consequent increase in environmental impact.

The Scale Effect of Trade

- The trade-induced increase in the *scale* of production and consumption causes an increase in the scale of environmental impact.

The Scale Effect of Trade

- A particularly important element of the scale effect of trade is the growth in the demand for energy.

The Scale Effect of Trade

- Example from China:
 - coal consumption rose by 14% in each of 2006 and 2007
 - a new coal-fired power plant opens every 10 days
 - China now uses more coal than the US, European Union and Japan combined

The Scale Effect of Trade

- The scale effect is perhaps the most obvious effect of trade on environmental quality, and it is one that has caused considerable concern among those who see trade as a negative influence on the global environment.
- However, this impact can potentially be offset by *a technique effect*.

5.3 The Technique Effect of Trade

The Technique Effect of Trade

- The increase in wealth that accompanies an expansion of trade is likely to induce an increased demand for environmental quality.
- Most empirical evidence indicates that environmental quality is a so-called “normal good”; that is, a good whose demand increases with wealth.

The Technique Effect of Trade

- This increase in the demand for improved environmental quality has the potential to create
 - market pressure on industry to improve its environmental performance
 - political pressure on governments to tighten their environmental policy standards.

The Technique Effect of Trade

- The primary mechanism for that improvement is the adoption of *cleaner production techniques*.
- This represents a substitution out of natural capital into knowledge capital.
- This substitution means that a given scale of production has a smaller impact on the environment.

The Technique Effect of Trade

- The technique effect of trade is crucial; it holds the key to fostering sustainable development through trade liberalization.
- The substitution of knowledge capital for natural capital has the potential to offset – and perhaps even more-than-offset – the negative scale effect of trade.

The Technique Effect of Trade

- However, a number of crucial links must be in place in order for the technique effect to operate fully:
 - effective market pressure
 - effective political pressure
 - forward-looking policy

Effective Market Pressure

- There must exist effective channels through which consumer demand can influence firms with respect to the environmental profile of their goods.
- Some key elements are needed:
 - competition
 - information
 - policy to address externalities

Competition

- Consumer pressure is most effective when consumers have the choice of switching brands if they are dissatisfied with the environmental profile of their current brand choice.

Information

- If consumers are to be able to influence the environmental profiles of the products they buy then they need to be well informed about those environmental profiles.
- Similarly, “green investors” need to be well-informed about the environmental practices of the firms in which they invest

Information

- There is an important role for policy intervention in this area:
 - labeling programs
 - certification programs

Policy to Address Externalities

- Even well-informed consumers with choices available act in their private interest. benefits accrued to person
- Private costs and benefits may not reflect true social costs and benefits due to the presence of externalities. damaging air that we breathe
impact on everyone else (dont consider)
- Policy - ensuring that prices reflect true social cost - is needed to address this.

social cost is different then private costs/benefits - most ppl don't usually consider others
there are now prices for air pollution/ congestions - to take them into account

TAGENT DAVID SUZUKI
'economics is a form of brain damage'

don't talk about things, that you know nothing of

Effective Market Pressure

- Market pressure can be weakened by the geographical separation of consumption and production associated with trade.

the goods we consume, are not necessarily produced in this country, so we may be limited to affect, if not in our own country - so we need international regulations

need to coordinate internationaly with policy

The Technique Effect of Trade

- effective market pressure
 - competition
 - information
 - policy to address externalities
- effective political pressure
- forward-looking policy

Effective Political Pressure

- There must exist effective channels through which consumers can bring pressure to bear on their politicians to implement stricter environmental policies.
- Well developed *social capital* is crucial to the realization of a production technique effect, and to the attainment of sustainable development in general.

The Technique Effect of Trade

- effective market pressure
- effective political pressure
- forward-looking policy

Forward-Looking Policy

- There can be long lags between the growth in wealth that spawns heightened concern for the environment, and the consumer pressure needed to induce the adoption of cleaner techniques.

Forward-Looking Policy

- If those lags are long enough, then extensive and irreversible damage may be done to the environment before individuals become wealthy enough to be concerned about it.
- It is therefore crucial that policy-makers be forward-looking rather than just reactive.

Forward-Looking Policy

- This kind of forward-looking policy is all too uncommon; policy is often based on very limited planning horizons associated with short-term electoral cycles.

Need to be looking looking more forward to future

5.4 The Composition Effect of Trade

The Composition Effect of Trade

- The scale and technique effects operate in the same directions for all trading countries:
 - the scale effect tends to impact negatively on the environment
 - the technique effect tends to impact positively.
- In contrast: The composition effect impacts different countries in opposite ways.

The Composition Effect of Trade

- The composition effect relates directly to the changes in production patterns that accompany specialization according to comparative advantage and the exploitation of scale economies.

The Composition Effect of Trade

- Consider two countries, A and B:
 - country A has a relative abundance of natural capital
 - country B has a relative abundance of other forms of economic capital.

The Composition Effect of Trade

- Specialization according to comparative advantage will tend to induce
 - a relative expansion of natural capital-intensive industries in country A
 - a relative expansion of non-natural capital-intensive industries in country B.
- The *composition* of production will change in both countries, but in opposite directions.

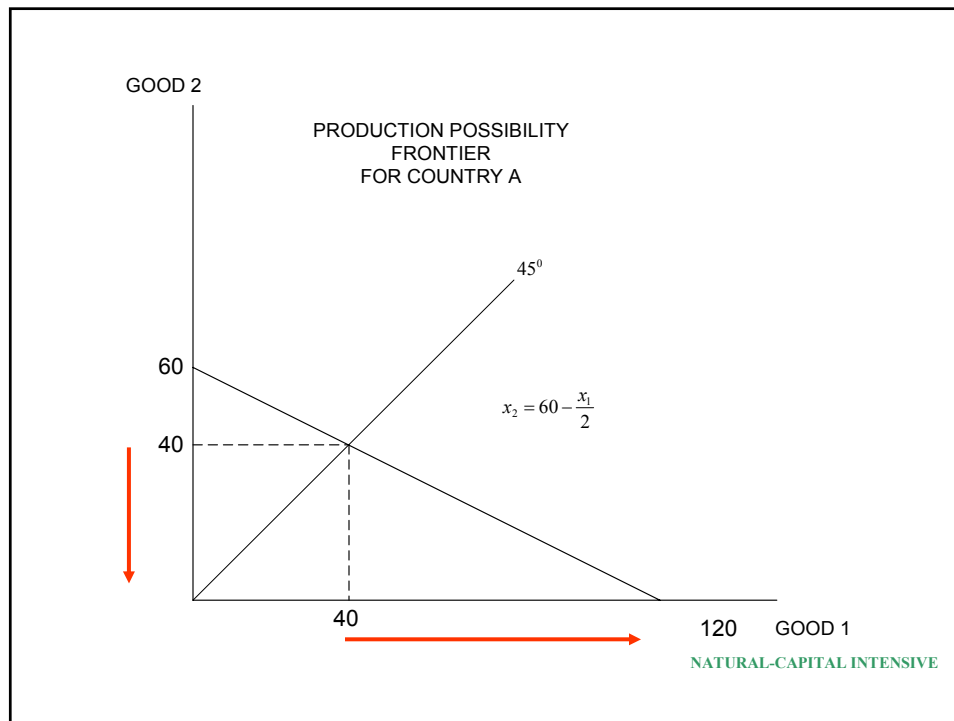

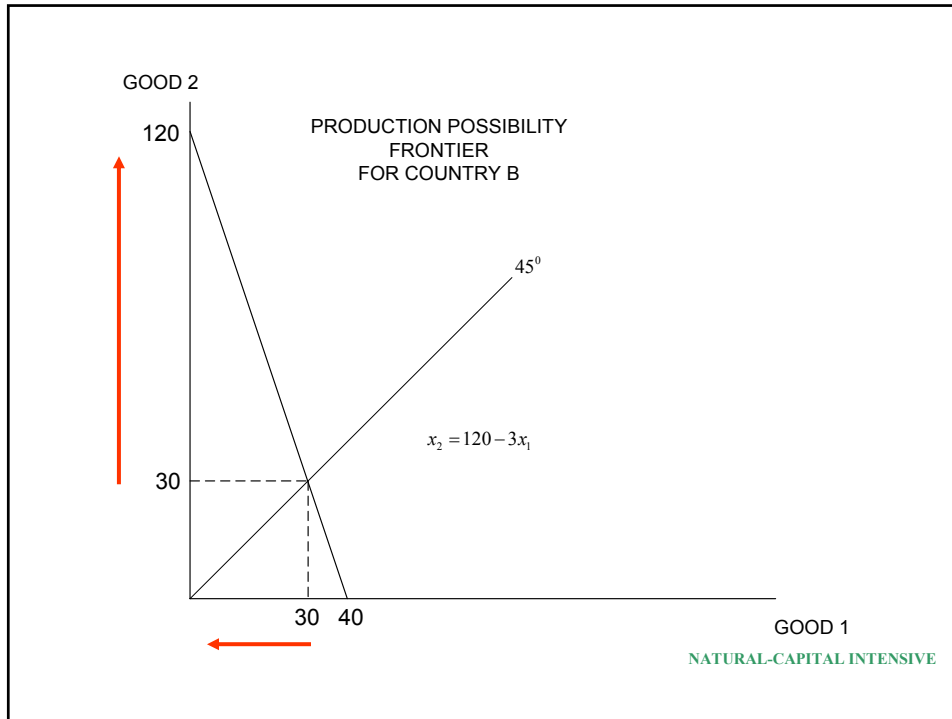

The Composition Effect of Trade

- The composition effect induces a negative environmental impact for some countries and a positive one for others.
- Countries with an abundance of natural capital relative to other forms of capital – especially knowledge capital – will tend to be affected negatively.

The Composition Effect of Trade

- It is important to note that specialization in *relatively* natural capital-intensive production does not necessarily mean a specialization in resource-based primary production.
- Polluting industrial activity can be relatively natural capital-intensive.

The Composition Effect of Trade

- It is this aspect of trade that underlies concerns that trade liberalization will induce a migration of relatively polluting industries to developing countries.

The Composition Effect of Trade

- However, an increase in *relatively* polluting industries –relative to those in developed countries – does not necessarily entail an increase in the *absolute* level of pollution.
- The technique effect of trade can mean that the absolute level of pollution actually declines even for countries that specialize in relatively polluting industries.

5.5 The Net Effect of Trade on the Environment: the Importance of Policy

The Net Effect of Trade

- Three effects of trade on the environment:
 - scale effect is negative
 - the technique effect is positive
 - the composition effect is positive for some countries and negative for others.
- So what is the likely net effect of trade on the environment?

The Net Effect of Trade

- The answer depends on policy.
- The key to fostering global sustainable development through trade is the technique effect (the substitution of knowledge capital for natural capital in production).
- Policy is needed to create the right incentives for innovation and technology adoption.

The Net Effect of Trade

- Policy design complicated by three issues:
 - structural adjustment (Chapters 6 and 7)
 - strategic interaction (Chapter 8)
 - transboundary pollution and the distribution of wealth (Chapter 9)

Tangent: The Environmental Kuznets Curve

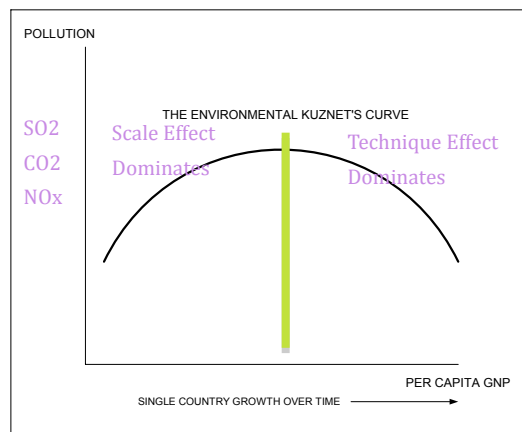

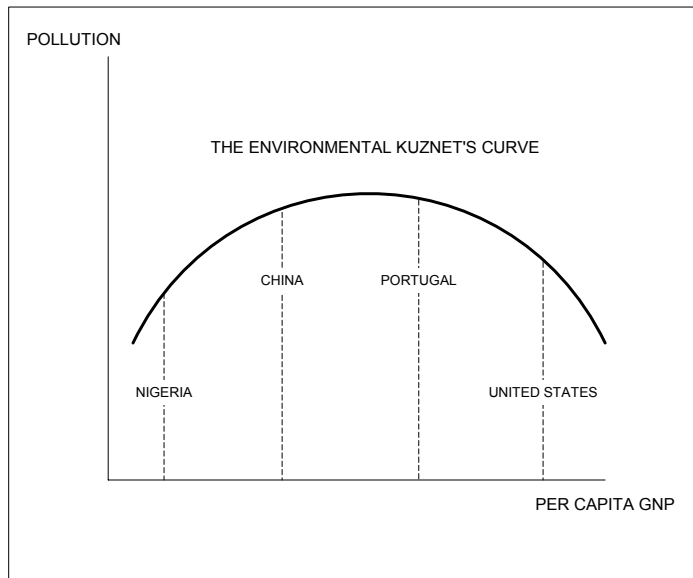

End

6. Trade Liberalization and Structural Adjustment

6.1 Introduction

Introduction

- Trade liberalization can precipitate substantial shifts in production patterns within an economy.
- Some sectors of the economy expand while other sectors contract.
- This means that trade liberalization can impose costs on some groups within society even while others derive benefits.

Introduction

- This chapter examines the key issues relating to structural adjustment:
 - a review of the adjustment that occurs in response to trade liberalization and how that adjustment affects different groups
 - discussion of key policy guidelines for the management of the structural adjustment process.

people lobby against change - and usually win

6.2 Trade Liberalization and Structural Adjustment

Trade Liberalization and Structural Adjustment

- Trade liberalization can lead to significant shifts in the patterns of production.
- The two principal forces at work
 - specialization according to comparative advantage
 - the exploitation of economies of scale and scope

Trade Liberalization and Structural Adjustment

- The combination of these two forces can cause complicated adjustments in the economy.
- These adjustments occur at two levels:
 - inter-sectoral adjustment
 - intra-sectoral adjustment

Inter-Sectoral Adjustment

- Inter-sectoral adjustment refers to adjustment across sectors according to factor intensities. (industrial categories)
- (Factor intensity refers to the mix of inputs – or factors – in the production process).
- This type of adjustment reflects specialization according to comparative advantage.

Inter-Sectoral Adjustment

- For example:
 - in wealthy countries, global trade liberalization has induced a shift towards knowledge-intensive manufacturing and services.
 - in the developing countries of Asia and Latin America, trade has induced a shift towards relatively low-skill labor-intensive, export-oriented manufacturing. This manufacturing also tends to be relatively pollution-intensive.

Inter-Sectoral Adjustment

- One important consequence of trade-induced inter-sectoral adjustment in developing countries is rapid urbanization. labour intensive, requires more people in central areas
- Manufacturing is concentrated in urban areas and the relative expansion of this sector has caused an influx of people from rural areas.
- See Chapter 7 for more discussion.

Intra-Sectoral Adjustment

- Intra-sectoral adjustment refers to adjustment across the industries and firms within a sector.
- This type of adjustment reflects the exploitation of economies of scale and scope.

Intra-Sectoral Adjustment

- Intra-sectoral adjustment can mean that
 - some industries and firms contract even though the sectors of which they are part expand on average
 - some firms and industries expand even though the sectors of which they are part contract on average.

6.3 Winners and Losers from Trade Liberalization

Winners and Losers from Trade Liberalization

- There are two main groups of beneficiaries from trade liberalization:
 - consumers access to greater range of goods
competitive pressure = cheaper prices
 - the stakeholders (workers, suppliers and shareholders) in industries that expand due to freer trade. thrive
- Those who lose from trade liberalization are the stakeholders in industries that contract.

people who lose their jobs, suppliers that lose clients

Winners and Losers from Trade Liberalization

- Typical textbook assertion:
 - trade liberalization is “welfare-enhancing”
- Translation:
 - the gains to the winners more than offset the losses to the losers
 - that is, the winners could, *in principle*, compensate the losers and still be better off.
 - a “potential Pareto improvement”

Winners and Losers from Trade Liberalization

- Nothing inherent about trade liberalization to ensure that winners actually compensate the losers.
- Trade liberalization can leave many groups worse off.

Winners and Losers from Trade Liberalization

- For some stakeholders, the costs of trade liberalization are likely to be short-lived:
 - well-diversified shareholders
 - workers with general skills that are easily transferred from one industry to another

Winners and Losers from Trade Liberalization

- For other stakeholders, the costs of adjustment are likely to be much higher, and much longer lived:
 - workers whose skills are highly specific to industries that fall into relative decline.

Tangent: Springsteen's "Youngstown"

- Springsteen (1995): *The Ghost of Tom Joad*
 - reference to John Steinbeck (1939): *Grapes of Wrath*
 - Steinbeck was awarded the Pulitzer Prize and the Nobel Prize for Literature
- Youngstown is the archetypal "rust belt" town in the Ohio Valley.

rust belt - part of mid western united states, manufacturing in decline due to trade liberalization

Excerpt from "Youngstown"

Well my daddy worked the furnaces
Kept 'em hotter than hell
I come home from 'Nam worked my way to scarfer
A job that'd suit the devil as well
Taconite, coke and limestone
Fed my children and made my pay
Them smokestacks reachin' like the arms of god
Into a beautiful sky of soot and clay

Excerpt from "Youngstown"

Well my daddy come on the Ohio works
When he come home from World War Two
Now the yard's just scrap and rubble
He said "Them big boys did what Hitler couldn't do."
These mills they built the tanks and bombs
That won this country's wars
We sent our sons to Korea and Vietnam
Now we're wondering what they were dyin' for

Growth, Trade and the Global
Environment

21

Excerpt from "Youngstown"

From the Monongahela valley
To the Mesabi iron range
To the coal mines of Appalachia
The story's always the same
Seven hundred tons of metal a day
Now sir you tell me the world's changed
Once I made you rich enough
Rich enough to forget my name

Growth, Trade and the Global
Environment

22

Excerpt from “Youngstown”

When I die I don't want no part of heaven
I would not do heaven's work well
I pray the devil comes and takes me
To stand in the fiery furnaces of hell

Growth, Trade and the Global
Environment

23

6.4 Policies for Managing Structural Adjustment

Policies for Managing Structural Adjustment

- Should we intervene to correct unequal impacts?
- Is “society” better off or worse when some of its members gain and others lose (especially when the losers are the least well-off in the first place)?

Policies for Managing Structural Adjustment

- These are - fundamentally - political questions, not economic ones.
- However, economic theory has something to say about inequality at a pragmatic level:
 - the tradeoff between equality and the creation of wealth.

The Trade-Off Between Equality and the Creation of Wealth

- The creation of wealth requires the existence of *incentives*.
- Equality of outcomes erodes those incentives (as for example, does taxation).
- Allowing some inequality in outcomes – which is quite distinct from inequality of opportunity – is essential to the creation of wealth.

Growth, Trade and the Global Environment

27

The Trade-Off Between Equality and the Creation of Wealth

- This negative relationship between equality of outcomes and wealth creation only extends so far.
- Extreme inequality undermines economic productivity for two important reasons:
 - risk of insurrection
 - asymmetric political pressure and growth-detering measures through lobbying.

Growth, Trade and the Global Environment

28

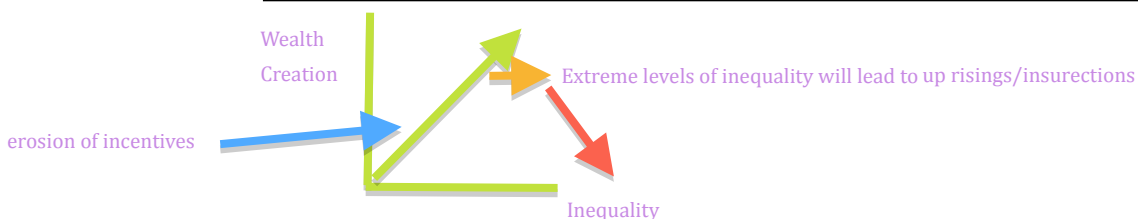

↑
Winners
-Consumers
-Stakeholders
Dispersed Benefit

↓
Losers
-stakeholders
-concentrated costs

The Trade-Off Between Equality and the Creation of Wealth

- Determining how much inequality to allow in a changing economy requires balancing
 - social justice
 - the creation of incentives
 - the prevention of damaging rent-seeking and political lobbying.

The Trade-Off Between Equality and the Creation of Wealth

- In general, achieving that balance will require some policy intervention to manage structural adjustment in response to trade liberalization.

extent? - depends on views of social justice

Principles for Managing Structural Adjustment

- First, structural adjustment should be managed rather than prevented:
 - generally inappropriate for government to support a declining industry with subsidies and indirect protectionist measures.
 - uncompetitive industries must be allowed to contract.

Principles for Managing Structural Adjustment

- *some* degree of domestic industrial concentration (that is, consolidation of industry into a fewer number of larger firms) will likely have to be allowed so that domestic companies can take advantage of scale economies

Principles for Managing Structural Adjustment

- Second, adjustment costs are usually lower if structural adjustment occurs slowly:
 - trade liberalization should be phased in over time, with changes announced well in advance, and *announced timetables for change* adhered to strictly.

Principles for Managing Structural Adjustment

- Third, incentive-based mitigation is likely to be far more productive than lump-sum compensation for affected individuals:
 - policies to assist displaced workers should typically be based on education and re-tooling – especially for younger workers – rather than on untied unemployment assistance.

Principles for Managing Structural Adjustment

- Fourth, management measures should foster economic flexibility:
 - it is almost always inappropriate for government to attempt to pick future “winners” and channel resources into those industries.
 - example from Ontario: clean energy

Principles for Managing Structural Adjustment

- the comparative advantage of government lies in the provision of political stability, enforceable property rights, general infrastructure and high quality general education.
- these *public factors* provide markets with a solid base from which to respond flexibly to changing global conditions.

End

7. Trade, Urbanization and the Environment

7.1 Introduction

Introduction

- Urbanization is one of the main consequences of the production shifts that accompany trade liberalization and technological change.
- The percentage of people living in cities is higher now than at any time in history, and the trend is towards further urbanization, especially in developing countries.

Introduction

- This chapter reviews the main issues with respect to trade, urbanization and the environment:
 - current trends towards urbanization
 - the link between urbanization and trade liberalization in developing countries
 - the main environmental impacts of urbanization
 - the role for policy with respect to urbanization.

7.2 Current Trends

Current Trends

- The fraction of the world's population living in urban areas:
 - 34% in 1974
 - 50% in 2000
 - projected to be 65% by 2020
- Over 5 billion people will be living in urban areas by the year 2020.

Current Trends

- The most rapid change is happening in developing countries.
- Urban population annual growth rates:
 - 3.5% in the developing world
 - 1% in developed countries

1	Tokyo	Japan	34.2
2	Mexico City	Mexico	22.8
3	Seoul	South Korea	22.3
4	New York	USA	21.9
5	Sao Paulo	Brazil	20.2
6	Bombay	India	19.9
7	Delhi	India	19.7
8	Shanghai	China	18.2
9	Los Angeles	USA	18.0
10	Osaka	Japan	16.8
11	Jakarta	Indonesia	16.5
12	Calcutta	India	15.7
13	Cairo	Egypt	15.6

14	Manila	Philippines	15.0
15	Karachi	Pakistan	14.3
16	Moscow	Russia	13.8
17	Buenos Aires	Argentina	13.5
18	Dhaka	Bangladesh	13.3
19	Rio de Janeiro	Brazil	12.2
20	Beijing	China	12.1
21	London	England	12.0
22	Tehran	Iran	11.9
23	Istanbul	Turkey	11.5
24	Lagos	Nigeria	11.1
25	Shenzhen	China	10.7
47	Toronto	Canada	4.6

Growth, Trade and the Global
Environment

9

Tangent: The Canadian Population

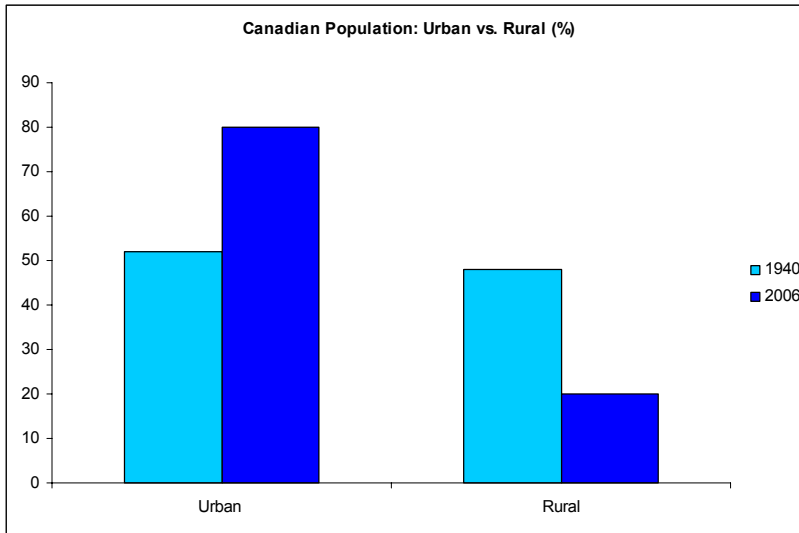

Growth, Trade and the Global Environment

11

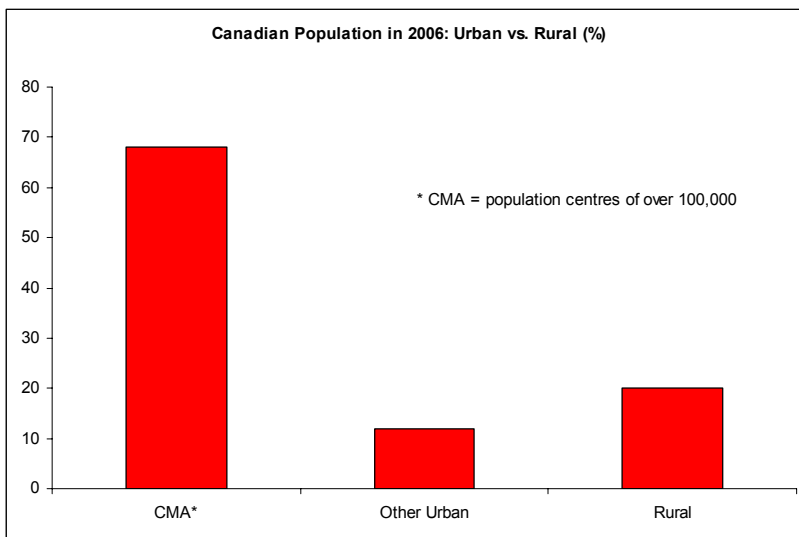

Growth, Trade and the Global Environment

12

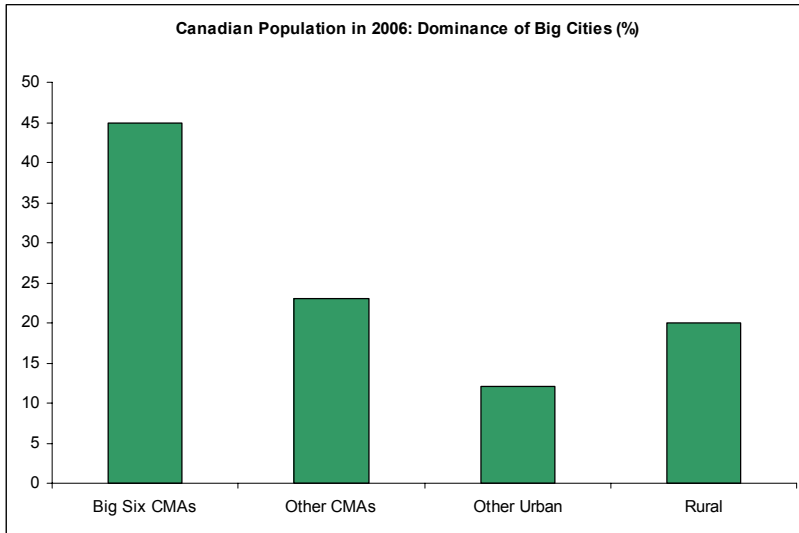

Growth, Trade and the Global Environment

13

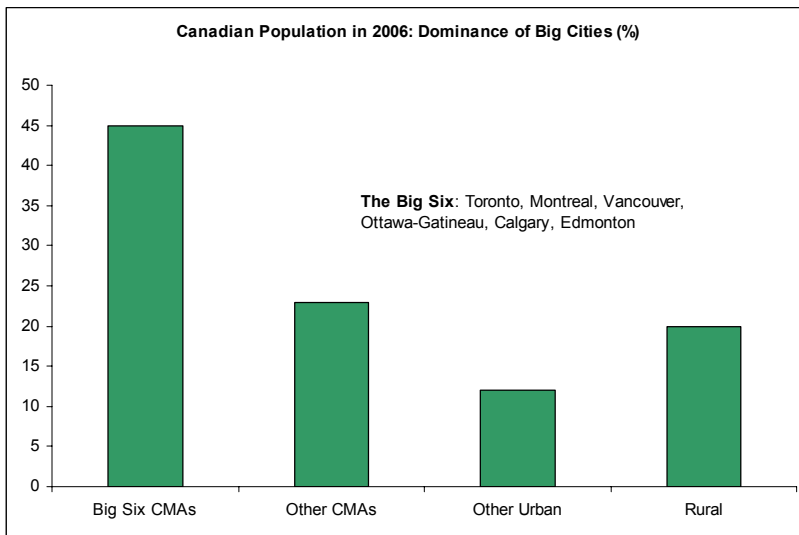

Growth, Trade and the Global Environment

14

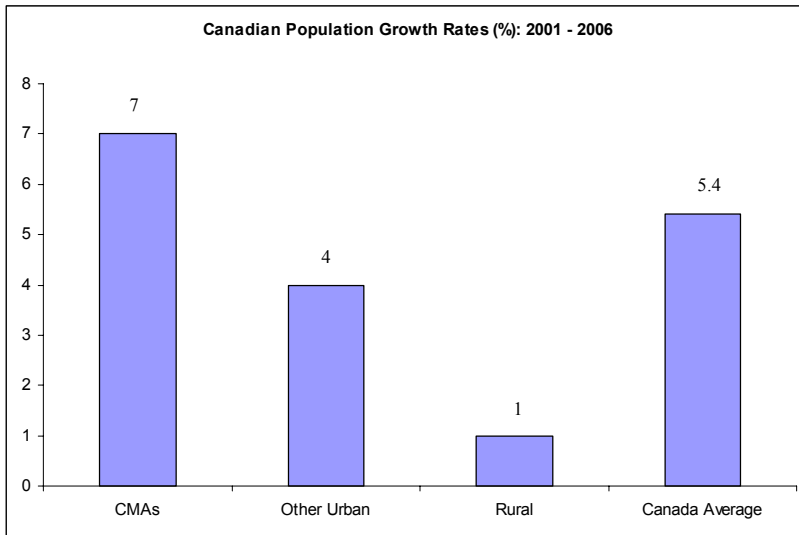

Growth, Trade and the Global Environment

15

7.3 Urbanization and Trade Liberalization

Urbanization and Trade Liberalization

- Our purpose here is to examine the determinants of rural-to-urban migration patterns and the implications for environmental quality.
- Consider Figures 7.1 and 7.2

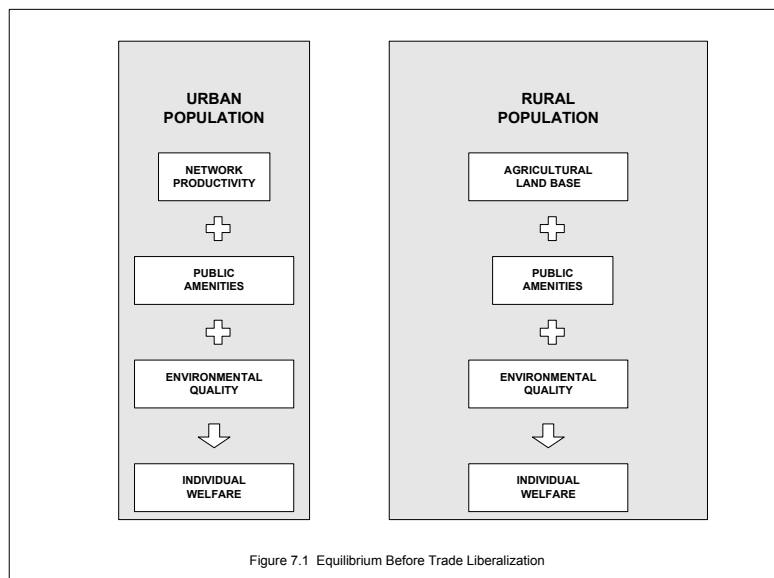

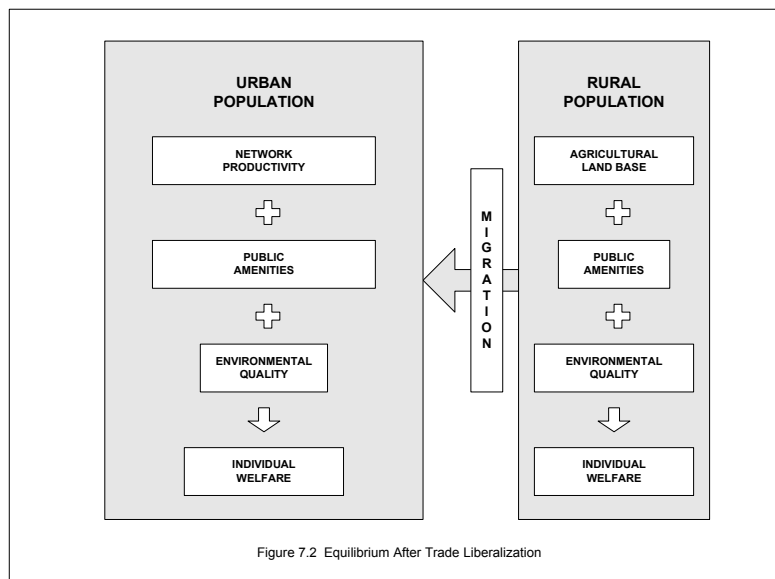

Figure 7.2 Equilibrium After Trade Liberalization

The Rural Economy

- Key determinants of individual welfare:
 - the agricultural land base
 - the level of public amenities and infrastructure (such as access to drinking water, sanitation, waste collection, health services, education, and communication and transportation links)
 - the level of environmental quality.

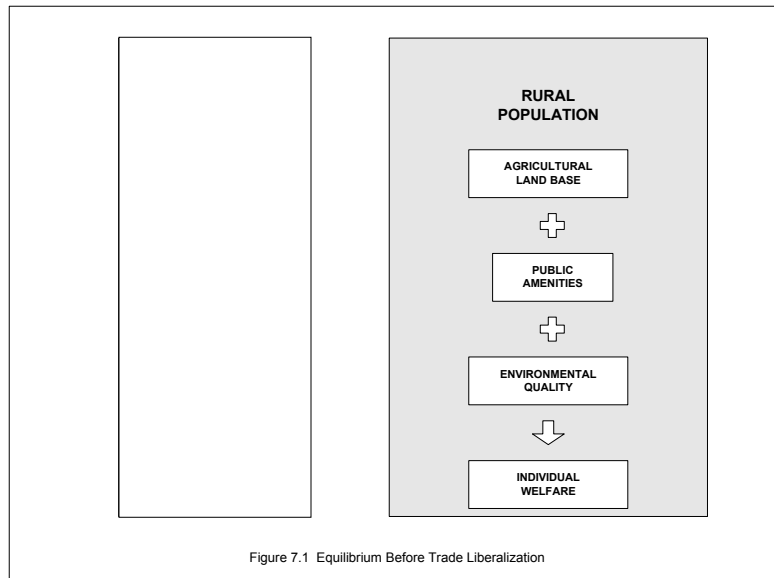
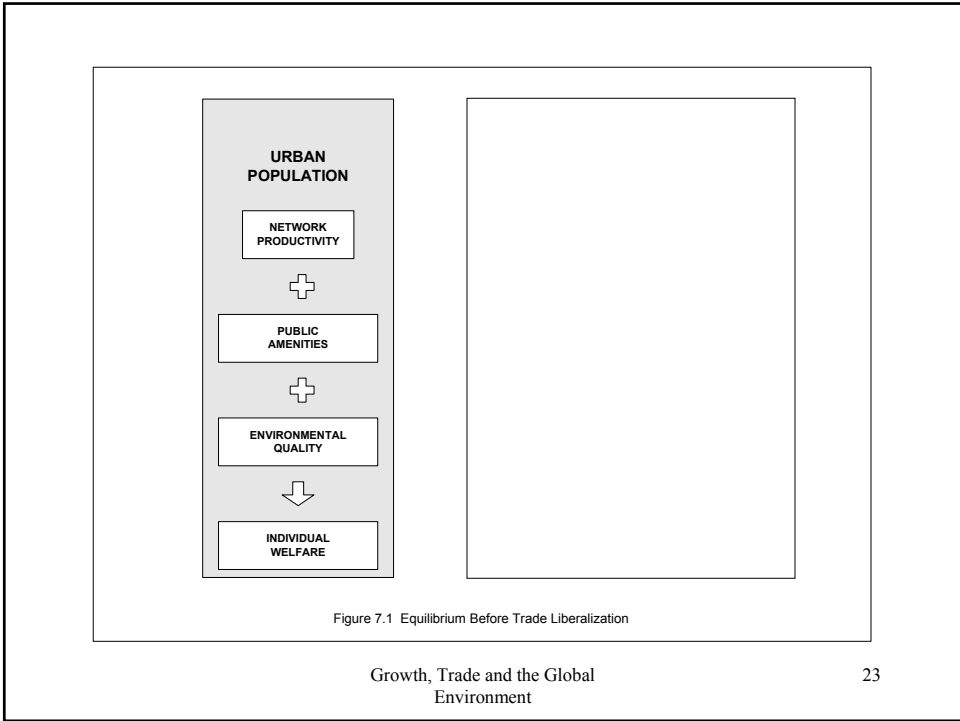

Figure 7.1 Equilibrium Before Trade Liberalization

The Urban Economy

- The primary determinants of wealth in the urban economy are manufacturing and services.
- The productivity of these sectors is determined largely by *network effects*.



The Urban Economy

- A network effect arises where the productivity of an activity or the use of a technology depends on the number of other people who are also engaged in that activity or using that technology.
- Standard examples:
 - telephones
 - computer operating systems.

Growth, Trade and the Global Environment 24

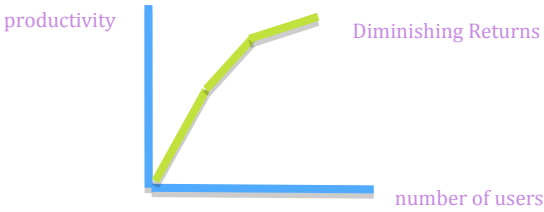

The Urban Economy

- Network effects pervade the manufacturing and service sectors, with respect to business contacts, information exchange, financial services, supply and distribution links, etc.

The Urban Economy

- The importance of network effects is one of the main reasons why the manufacturing and service sectors typically locate in cities:
 - the productivity of business networks relies to a large degree on people being within close proximity to each other.

The Urban Economy

- The network effects that bring people together in cities also facilitate the exploitation of *economies of scale and scope* in the provision of public amenities and infrastructure.

The Urban Economy

- This means that cities tend to be the engines of their own growth (**self-agglomeration**):
 - public factors boost the productivity of industry and foster the creation of additional wealth.
 - the creation of wealth allows the provision of additional infrastructure and amenities and draws more people to the cities.

The Urban Economy

- Three key factors limit the returns to city size:
 - economies of scale and scope in the provision of infrastructure and amenities eventually become exhausted
 - diminishing returns to network size

The Urban Economy

- the environmental resources of the city region are finite and so become stressed under the impact of the increasing production and consumption activity.
- Environmental stress manifests itself as air pollution, crowding, noise pollution, sanitation problems, solid waste problems, water pollution, etc.

Equilibrium

- People migrate to cities from rural areas because they expect a higher standard of living in the city.
- That migration continues until the level of welfare for an individual of given private wealth is more-or-less equated in the two regions.

Equilibrium

- Relocation costs will present an obstacle to migration for many people, so the equality of individual welfare is not exact.
- Moreover, misinformed beliefs may lead some people to migrate and actually become worse off, but the cost of relocation prevents them from returning to their original location.

Equilibrium

- In equilibrium, the productivity of the agricultural land base in the rural region is sufficiently high relative to the opportunities available in the urban industrial sectors that it just compensates for the relative lack of public amenities in the rural sector.

Equilibrium

- Many events can disrupt the relative population equilibrium between the rural and urban regions:
 - war, drought or pestilence in the rural area
 - disease outbreak or recession in urban regions
 - *absolute* population growth in both regions (especially since the agricultural land base is often strictly limited).

Equilibrium

- The “disruptive” event on which we wish to focus here is trade liberalization.

The Effect of Trade Liberalization

- Trade liberalization for many developing countries - especially in Asia and Latin America - has meant a shift in relative production patterns towards relatively low-skill labor-intensive, export-oriented manufacturing, reflective of comparative advantage.
- This shift favors the urban economy.

The Effect of Trade Liberalization

- In particular, the productivity of the urban industrial network has grown substantially as a result of trade liberalization.
- All other things equal, this would lead to a higher level of welfare for urban dwellers.

The Effect of Trade Liberalization

- However, that imbalance between relative welfare levels for rural and urban dwellers cannot persist as an equilibrium.
- Consequently, there is a migration from rural to urban areas.

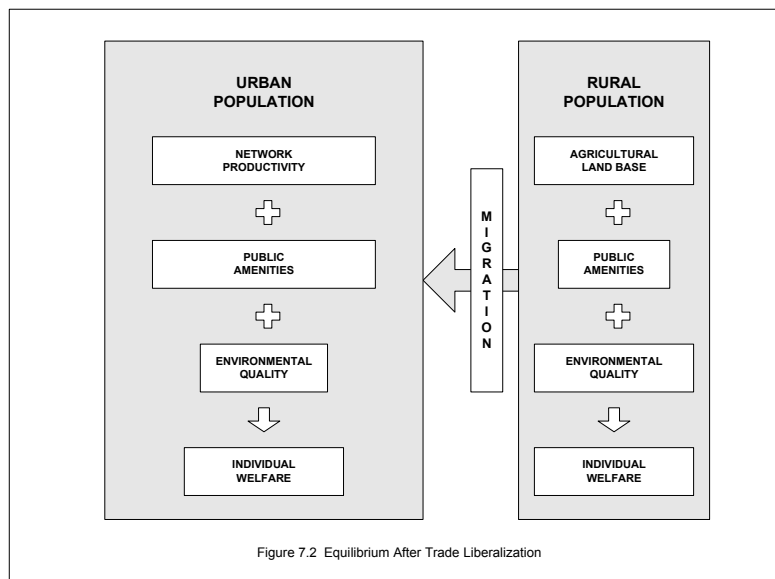

Figure 7.2 Equilibrium After Trade Liberalization

The Effect of Trade Liberalization

- Migration continues until welfare levels in the two regions are again equated.
- Three things bring about this equalization:
 - enhanced *per-capita* productivity in the rural region (associated with fewer people relying on the fixed agricultural land base)

The Effect of Trade Liberalization

- diminishing returns to labor in the urban industries (reflected as lower relative wages for manufacturing workers)
- reduced relative environmental quality in the urban region due to the increased scale of economic activity.

The Effect of Trade Liberalization

- The ensuing equilibrium involves a more productive urban industrial network, more urban infrastructure and public amenities, but lower relative environmental quality than before trade liberalization.

Relative vs. Absolute Environmental Quality

- Note that environmental quality in the urban area falls relative to that in the rural area but the *absolute* level of environmental quality in rural *and* urban areas could be higher after trade liberalization.
- Why? The technique effect of trade.

7.4 The Environmental Impact of Urbanization

The Environmental Impact of Urbanization

- The environmental impacts of urbanization stem from
 - the sheer number of people drawing upon limited assimilative capacity
 - the types of economic activity that typically characterize urban areas (such as manufacturing).

The Environmental Impact of Urbanization

- The main urban environmental problems are
 - air pollution
 - solid and hazardous waste disposal
 - wastewater disposal
 - water supply and sanitation problems

- Housing

7.5 Urbanization and the Environment: the Role for Policy

Urbanization and the Environment: the Role for Policy

- Our objective here is to characterize the “big picture” with respect to policy intervention.

Urbanization and the Environment: the Role for Policy

- Basic principle of all policy intervention:
 - implement a resource allocation target as a corrected equilibrium through the application of policy instruments to change private incentives.
- The resource allocation target is specified with respect to some welfare criterion; sustainable development is one such a criterion.

Urbanization and the Environment: the Role for Policy

- The key to good policy design is to first identify the important **private choices** that determine equilibrium outcomes, since this determines where policy instruments need to be targeted.
- Consider Figure 7.3.

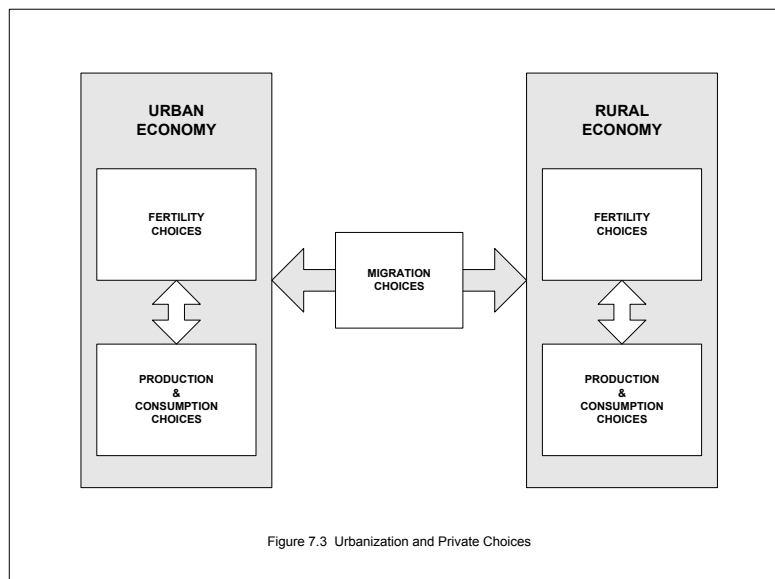

Figure 7.3 Urbanization and Private Choices

Urbanization and the Environment: the Role for Policy

- It is important to be clear what is meant by a “choice” in the economic sense:
 - an action based on preferences subject to the *constraints* faced by the individual.

Urbanization and the Environment: the Role for Policy

- For the urban poor in developing countries, the constraints may be so limiting as to allow only one action with respect to some activities.
- The action is nonetheless a “choice” in the economic sense.

Urbanization and the Environment: the Role for Policy

- Consider the choices that determine the quality of the urban and rural environments; see Figure 7.3

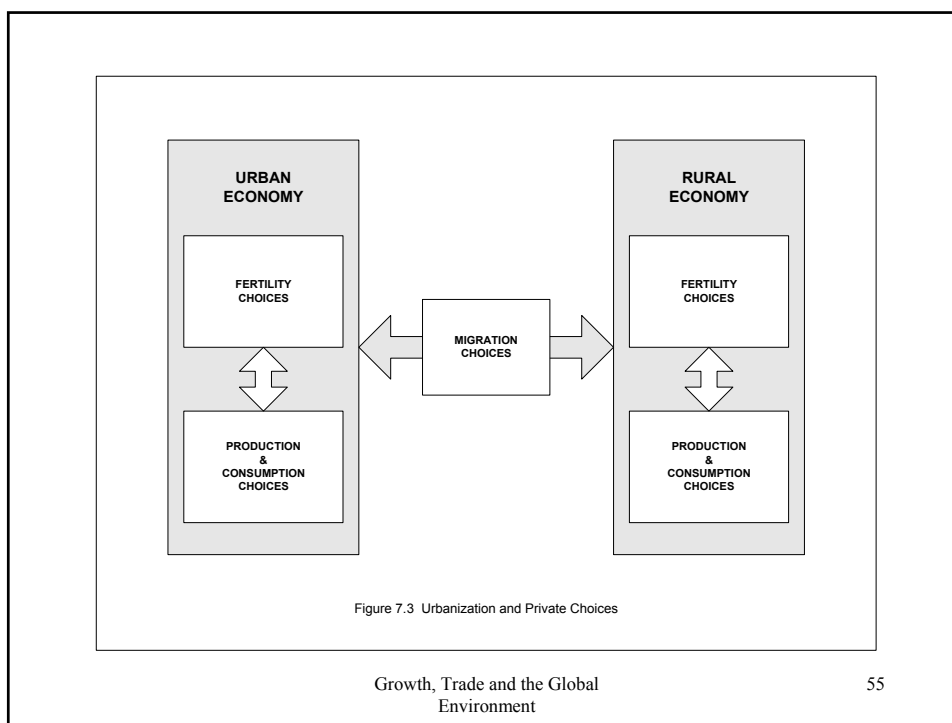

Urbanization and the Environment: the Role for Policy

- These choices are of course inter-related:
 - fertility and migration choices affect the constraints that in turn influence choices with respect to production and consumption
 - the production and consumption opportunities available affect migration and fertility choices.

Urbanization and the Environment: the Role for Policy

- A role for policy arises where the equilibrium outcome from private choices does not correspond to the resource allocation target as specified in terms of the welfare criterion.
- In particular, the equilibrium arising from private choices may not correspond to sustainable development.

Urbanization and the Environment: the Role for Policy

- Why?
 - a divergence of private costs and benefits from social costs and benefits.
- An important cause of that divergence is the presence of *externalities*.

Urbanization and the Environment: the Role for Policy

- An externality is a cost or benefit associated with an activity that is external to (that is, not felt by) the individual undertaking the activity.
- Externalities arise at all three choice levels illustrated in Figure 7.3.
- Consider each level in turn.

Externalities Associated With Production and Consumption

- If an individual (or firm) does not have to pay a price for the pollution they cause, then they have no incentive to take into account the impact of that pollution on others in their production and consumption choices.
- This will generally lead to a higher level of pollution than is optimal from a social perspective.

Externalities Associated With Fertility

- The private cost of fertility is generally less than the social cost.
- Why?
 - unpriced externalities associated with the production and consumption choices that children will make when they become adults
 - child-related subsidies, and publicly funded child health and education programs.

Externalities Associated With Fertility

- On the other hand, social benefits of fertility exceed the private benefits (that is, a positive externality from fertility):
 - the provision of young workers to provide productive trading opportunities for those too old to produce for themselves.
- On balance, there could be too little fertility or too much.

Aside: Dependency Rates

- The dependency rate for a country is the number of non-working age people per working age person.
- Estimate for Japan in 2050: 100%
- Forecast median age: 52

Externalities Associated With Fertility

- Any attempt to address the environmental problems associated with urbanization (and environmental issues more generally) must recognize the importance of fertility & population growth.
- This issue currently receives far less attention than it deserves.

Externalities Associated With Migration

- Two important externalities here:
 - no account of increased environmental impacts at new location or reduced environmental impacts at old location
 - economies of scale in infrastructure provision

Key Principles for Policy Design

- Specific policies: see Chapter 10.
- Two key policy design principles:
 - policy should *target the source of the problem*
 - under most circumstances, the best way to address an externality problem is to *internalize it through pricing* (tax external costs, subsidize external benefits).

Tangent: Population Growth

- The UN estimates that the global population reached 7 billion on 31 October 2011.
- The UN “medium fertility variant” projection is that population will stabilize at about 10 billion by 2080.
- In 1800, the global population was 1 billion.

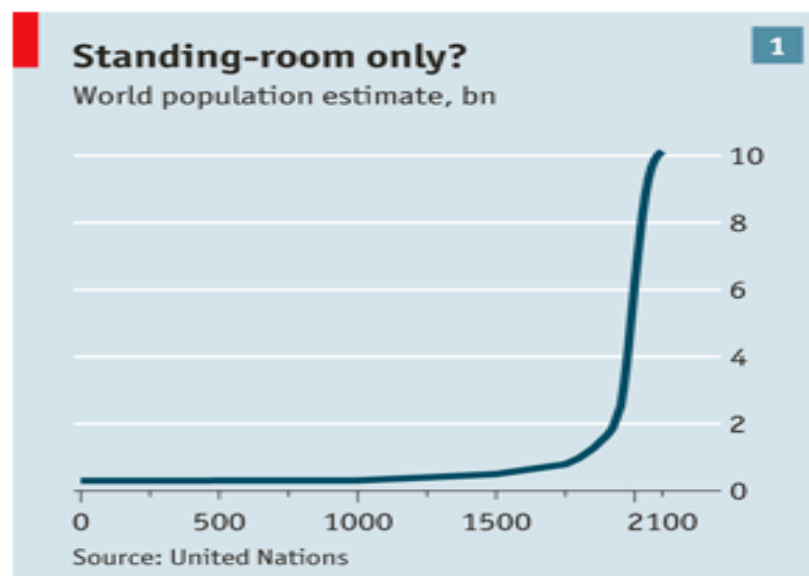
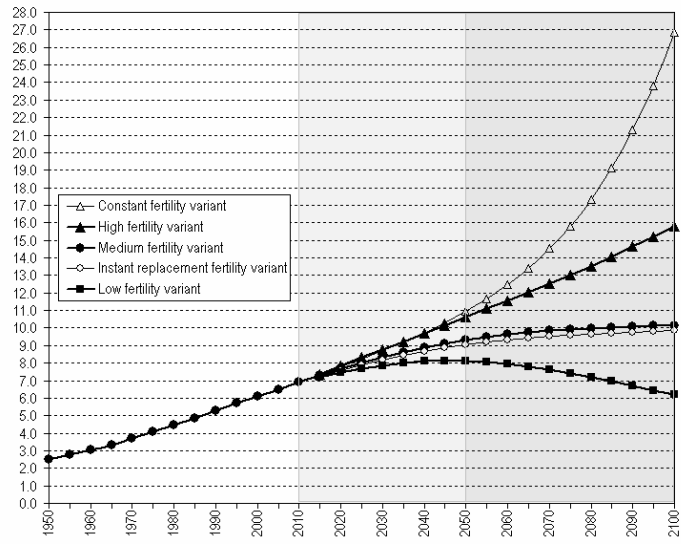

Figure 1: Estimated and projected world population according to different variants, 1950-2100 (billions)



Growth, Trade and the Global Environment

A staggering decline

World fertility rate*, five-year average

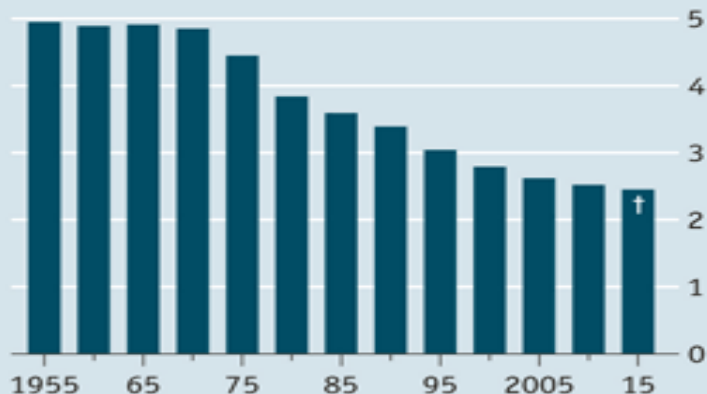

Source: United Nations *Live births per woman †Forecast

Growth, Trade and the Global Environment

Tangent: Population Growth

- There are wide variations across countries in terms of fertility rates.
- Much of the population growth will occur in sub-Saharan Africa

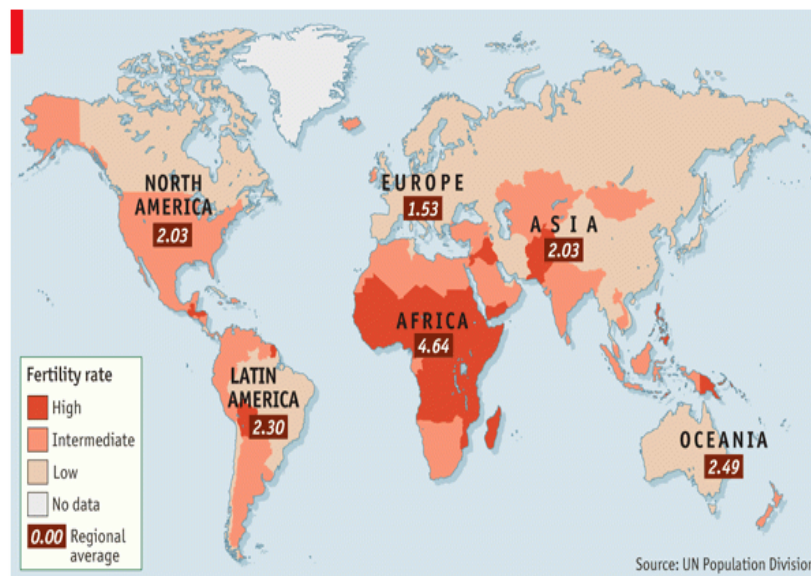

RELIGION AFFECTS FERTILITY RATES

Is it a Problem?

- There are a range of views as to whether population growth is a cause for concern.

An Optimistic View: from *The Economist* (22 Oct 2011)

- The big problem for agriculture is not the number of people, but signs that farm productivity may be levelling out. The growth in agricultural yields seems to be slowing down. There is little new farmland available. Water shortages are chronic and fertilisers are over-used.

output per
acre



From *The Economist* (22 Oct 2011)

– All these—plus the yield-reductions that may come from climate change, and wastefulness in getting food to markets—mean that **the big problems are to do with supply, not demand.** (emphasis added)

- Are they serious?

Growth, Trade and the Global
Environment

75

End



8. Trade, Competitiveness and the Environment

8.1 Introduction

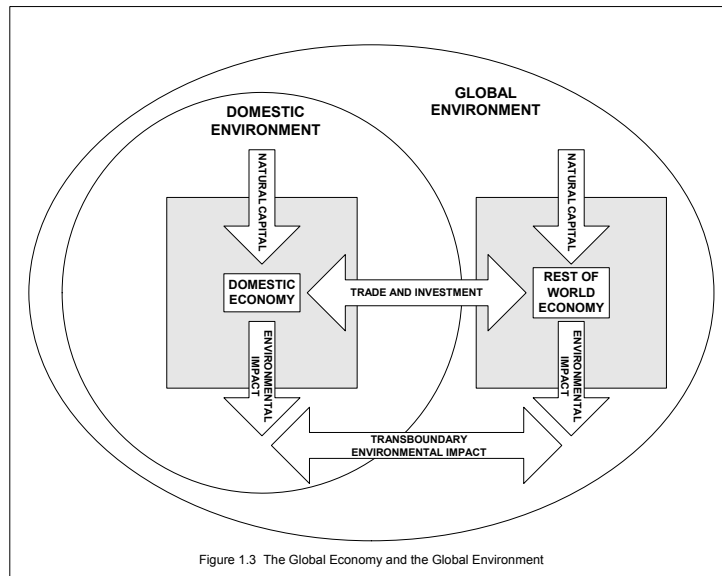

Figure 1.3 The Global Economy and the Global Environment

Growth, Trade and the Global Environment

3

Introduction

- Recall from Chapter 1 that the link between trade and the environment is bi-directional:
 - the production and consumption patterns associated with trade have substantial environment impacts
 - the policies designed to manage environmental impacts have important implications for competitiveness and the pattern of trade

Growth, Trade and the Global Environment

4

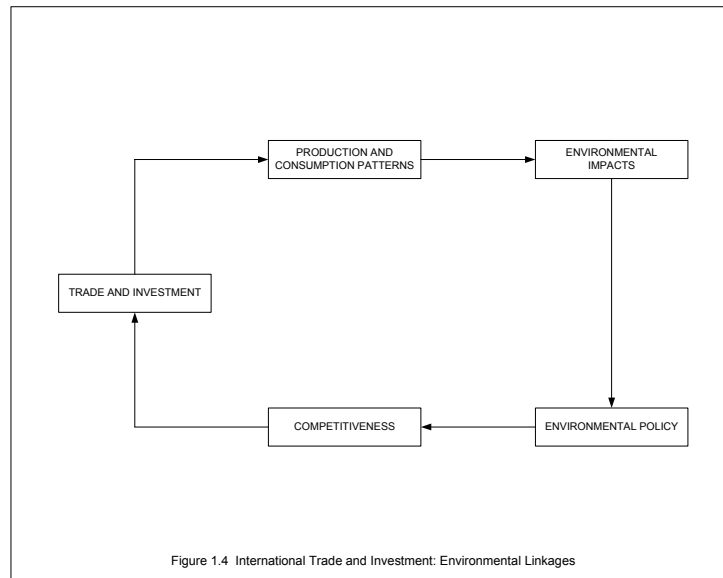
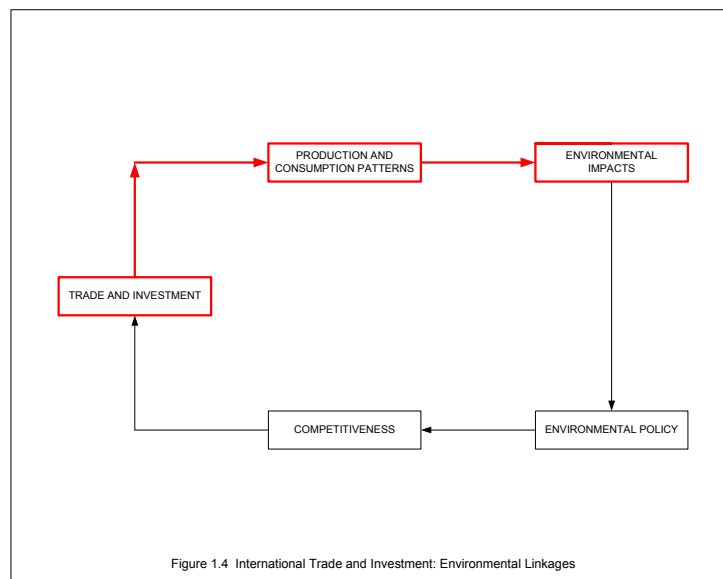

Figure 1.4 International Trade and Investment: Environmental Linkages

Introduction

- In Chapters 5 and 7 we focussed on the first of these links.



Introduction

- In this chapter we focus on the second.

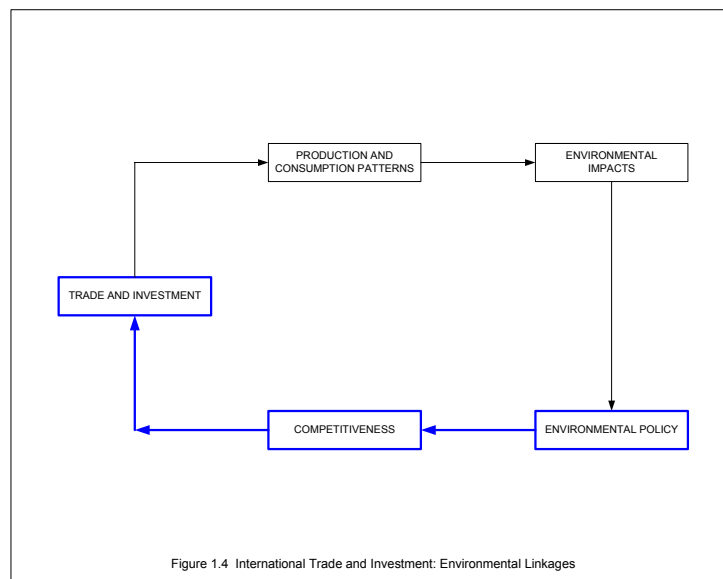

Figure 1.4 International Trade and Investment: Environmental Linkages

Introduction

- Our discussion will proceed as follows:
 - imperfect global competition and its relationship to the existence of economic rents
 - implications for the link between environmental policy and international competitiveness
 - the need for international cooperation, and the integration of environmental accords into trade liberalization agreements

8. 2 Imperfect Competition and Global Trade

Imperfect Competition and Global Trade

- Gains from trade liberalization stem from
 - specialization in production according to comparative advantage
 - the exploitation of economies of scale and scope
- At the same time, economies of scale can lead to concentration in the associated industries.

Imperfect Competition and Global Trade

- On the positive side:
 - the exploitation of economies of scale and scope through concentration can lead to substantial reductions in production costs Price > Cost
- On the negative side:
 - “imperfect competition”, where prices can be set well above production cost due to the absence of competitive pressure.

Imperfect Competition and Global Trade

- This means that the firms involved make *economic rent*:
 - ***** – a return on their investment higher than is ***** needed to make that investment worthwhile.
- This economic rent will be captured by
 - shareholders
 - labor (in the form of high-paying jobs)
 - government (through taxation)

Imperfect Competition and Global Trade

- What are the implications for environmental policy?

8.3 Environmental Policy and Competitiveness

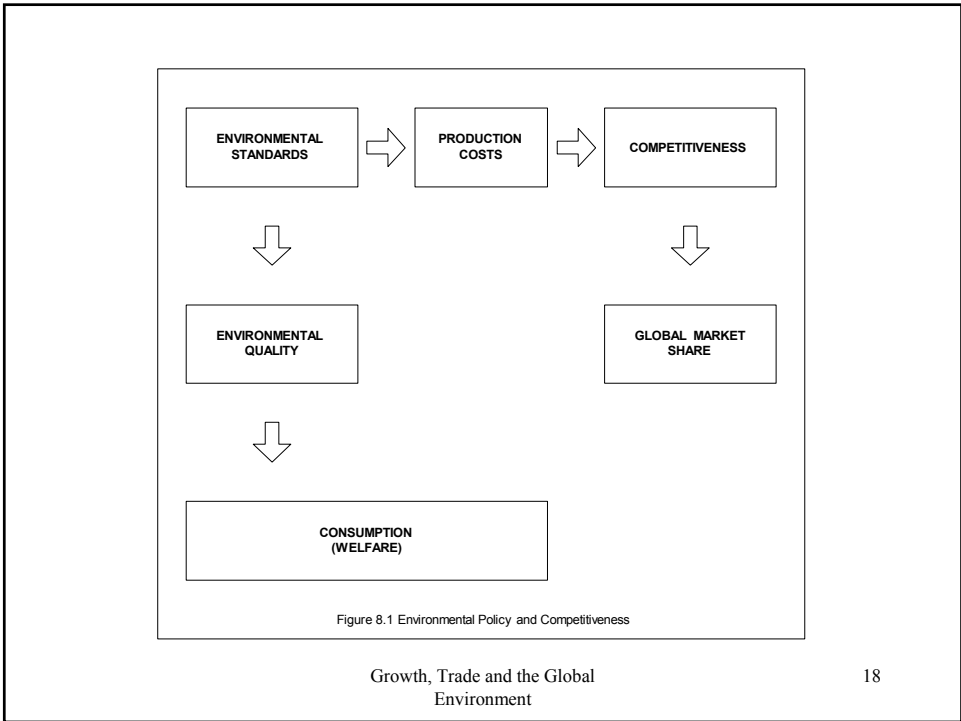
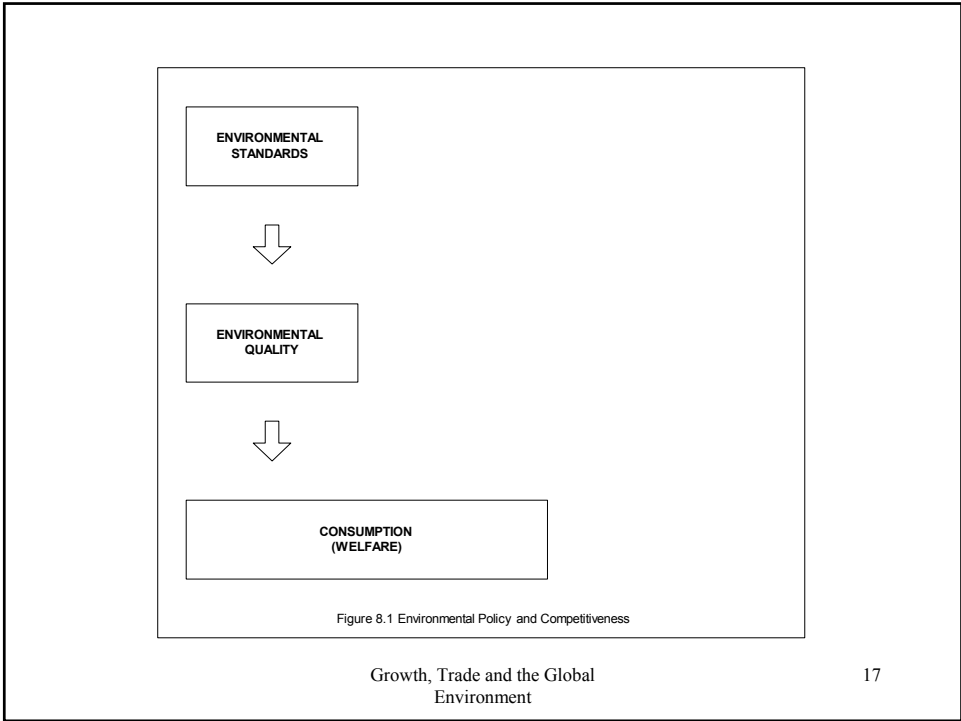

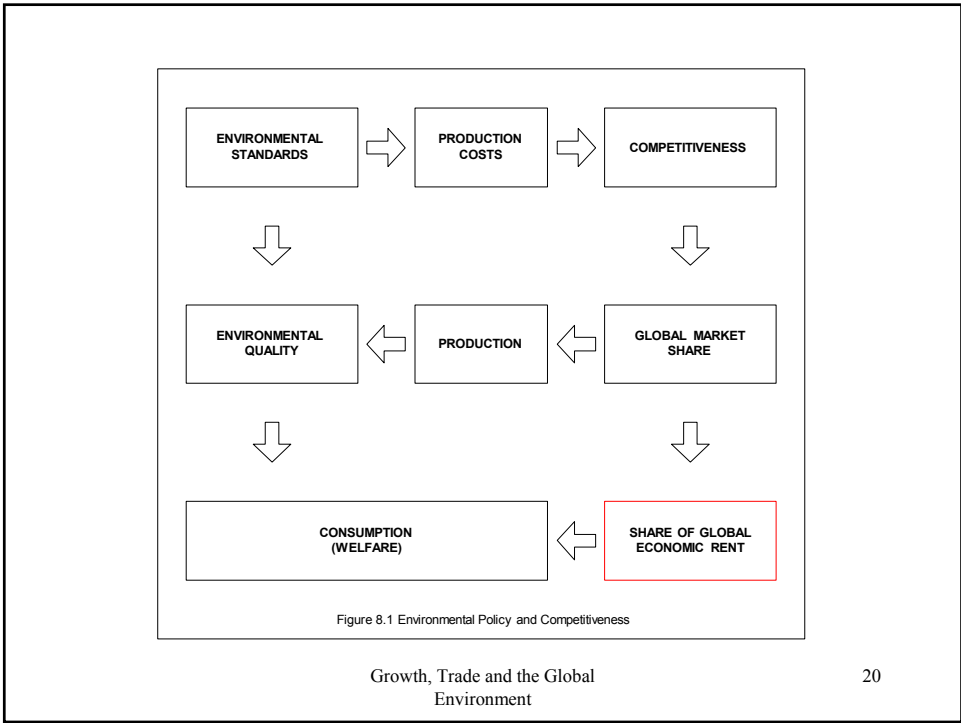
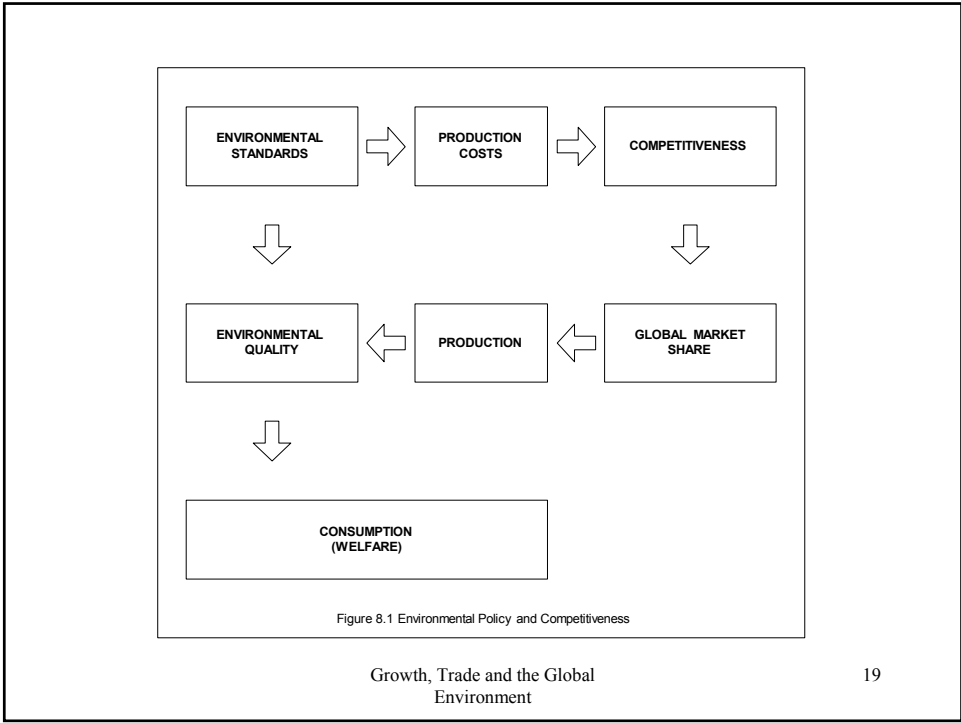

Competitiveness and the Share of Global Economic Rent

- Erosion of competitiveness leads to a loss of economic rent through three channels:
 - existing domestic producers lose market share and cut production
 - firms have an incentive to relocate to jurisdictions that have lower costs (pollution havens)
 - new investment tends to flow where production costs are lower

Some Important Qualifications

- The negative relationship between environmental standards and international competitiveness may not hold universally due to:
 - the productivity costs of poor environmental quality
 - the promotion of technological change
 - environmental protectionism

8.4 The Productivity Costs of Poor Environmental Quality

The Productivity Costs of Poor Environmental Quality

- Poor environmental quality overall can cause cost increases through reduced productivity, via
 - human health effects and higher effective labor costs
 - damage to other productive elements of natural capital
 - environmental conflict and political instability

8.5 The Promotion of Technological Change

The Promotion of Technological Change

- “Porter hypothesis”:
 - strict environmental standards can actually enhance competitiveness through the promotion of “technological leadership”
- This does not have strong empirical support or theoretical foundation.
- However, it does highlight the importance of knowledge and technological change.

The Promotion of Technological Change

- The key to fostering innovative effort:
 - create incentives through pricing environmental damage
- However, excessively strict standards designed to force more rapid innovation can be very costly (since innovative effort is costly).

The Promotion of Technological Change

- But there are many obstacles to innovation:
 - imperfect capital markets
 - appropriation problems
- *Targeted policies* (such as venture capital tax breaks and patent regulations) - not excessively strict environmental policy - should be used to address these obstacles.

8.6 Environmental Protectionism

Environmental Protectionism

- Strict environmental standards imposed on production in the domestic economy will typically erode international competitiveness.
- In contrast, strict environmental standards for imported goods can do just the opposite:
 - they can give a competitive edge to domestic producers who compete with those imports.

Environmental Protectionism

- Imposing restrictions on imported goods can sometimes be justified on legitimate environmental grounds:
 - environmental impacts associated with consumption in the importing country
 - transboundary pollution from production in the exporting country

green house gasses are transboundary - therefore put restrictions by 'import tax' for goods that produce green house gas in other countries that do not have limits

Environmental Protectionism

- In other instances, the case is more difficult to justify:
 - for example, psychic transboundary costs rather than physical damage
- Psychic costs are a legitimate economic cost but they are difficult to prove.

Environmental Protectionism

- The line between environmental management and environmental protectionism can also be blurred by product certification programs (such as ISO 14000) and “eco-labeling”:
 - they typically (and inappropriately) impose uniform standards for certification (for rich and poor countries alike)

The Potential for a “Race to the Bottom”

- We have considered three qualifications to the negative link between strict environmental standards and the share of global economic rent:
 - the productivity costs of poor environmental quality
 - the promotion of technological change
 - environmental protectionism

The Potential for a “Race to the Bottom”

- Now let us return to the implications of a negative link (due to the impact of regulations on production costs):
 - the potential for a race to the bottom

8.7 The Potential for a “Race to the Bottom”

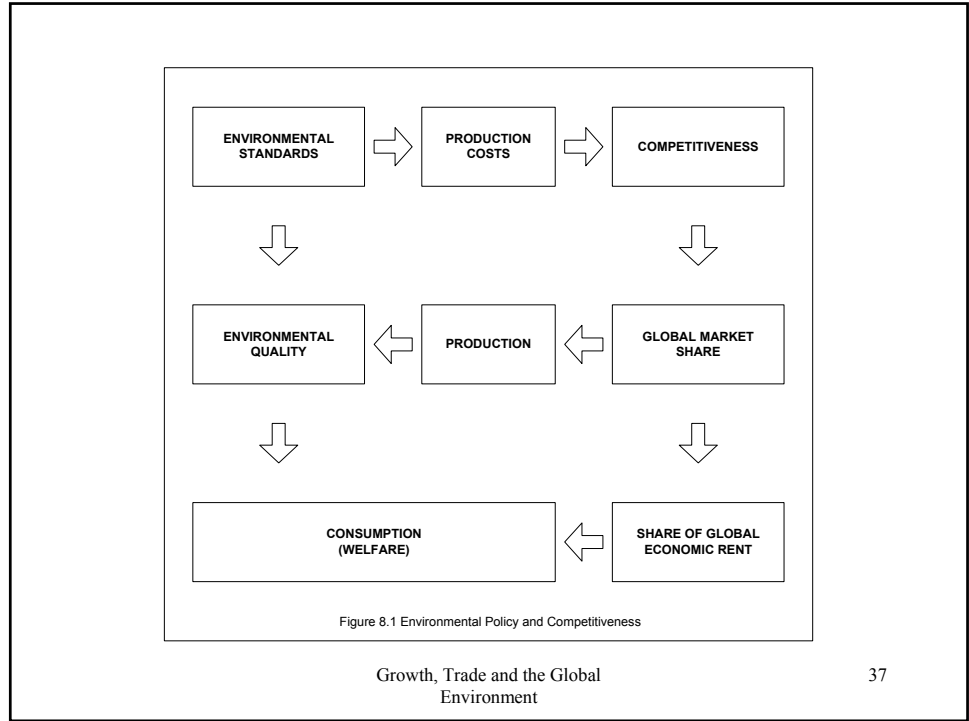

The Potential for a “Race to the Bottom”

- Each country has an incentive to relax its environmental standards to gain a competitive edge (in the form of lower costs) for its firms.
- However, no country actually achieves that competitive edge because all countries act in the same way.

The Potential for a “Race to the Bottom”

- The result:
 - a Nash equilibrium with lax environmental standards and lower welfare for all countries.

Tangent: the Prisoners’ Dilemma Game

< 2 >

		C	D
< 1 >	C	*	2, 5
	D	4, 4	NE 3, 3

one shot game - will defect - because no consequence from that

The Potential for a “Race to the Bottom”

- What is the solution to this “race to the bottom” problem?
 - international cooperation and policy integration

8.8 Integration and International Cooperation

Integration and International Cooperation

- Trade liberalization does not eliminate the incentive for individual countries to attempt to capture a larger share of global rents; trade liberalization simply restricts the set of policy instruments available for that purpose.

Integration and International Cooperation

- As the use of tariffs and quotas is restricted, non-trade policy instruments – such as environmental standards, health and safety standards, and tax policies – are often distorted to pursue trade-related objectives.
- This can mean that the net benefits of trade liberalization are greatly diminished.

Integration and International Cooperation

- Key implication:
 - mutually beneficial multilateralism must involve more than trade liberalization alone
- Trade liberalization agreements should include comprehensive side agreements on environmental protection (and other social policies).

Integration and International Cooperation

- Achieving such agreements is complicated by the presence of transboundary pollution and the highly skewed distribution of global wealth.
- This is the subject of Chapter 9.

End

9. Trade, Transboundary Pollution and the Distribution of Global Wealth

9.1 Introduction

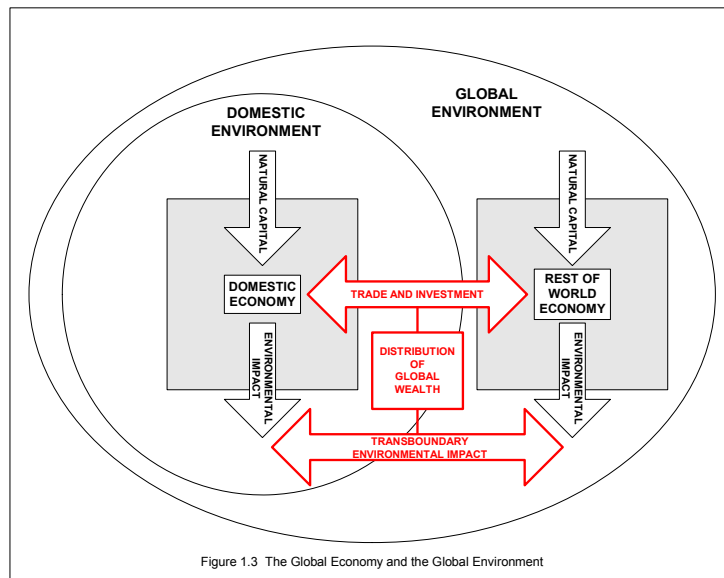
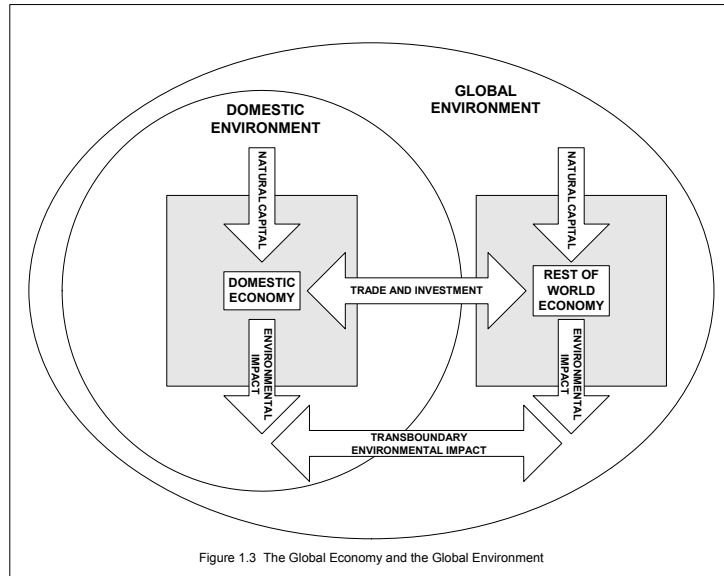

9.2 The Transboundary Pollution Problem

The Transboundary Pollution Problem

- Transboundary environmental impacts:
 - those whose effects are felt beyond the boundaries of the country (or the province or the state) in which the source activity is undertaken.

The Transboundary Pollution Problem

- Transboundary pollution is an *international negative externality*:
 - a cost imposed on other countries for which the polluting country does not have to pay.
- That external cost is not taken into account by the polluting country when setting its own environmental standards.

The Transboundary Pollution Problem

- Consequence:
 - standards are set too low from a global perspective.

Tangent: the Prisoners' Dilemma Again

< 2 >

		C	D
< 1 >	C	*	2, 5
	D	5, 2	NE 3, 3

9.3 Transboundary Pollution and the Trade-Related Distortion of Environmental Policy

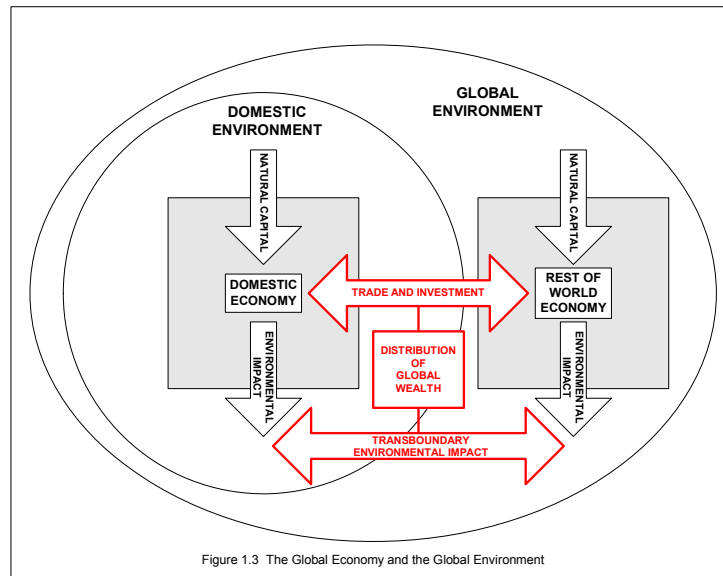

Transboundary Pollution and the Trade-Related Distortion of Environmental Policy

- Recall from Chapter 8:
 - individual countries may have an incentive to relax environmental standards in order to boost their international competitiveness.

Transboundary Pollution and the Trade-Related Distortion of
Environmental Policy

- Transboundary pollution flows can exacerbate that problem, for two reasons:
 - the trade-related distortion gives rise to a higher level of pollution from each country which in turns leads to a higher flow of transboundary pollution.

Transboundary Pollution and the Trade-Related Distortion of
Environmental Policy

- the transboundary nature of the pollution means that the environmental cost to any individual country from relaxing its standards for rent-seeking goals is smaller than it would be if the entire effects of its pollution were felt within its borders.
 - ⇒ leads each country to relax its standards by an even larger degree than it otherwise would.

Transboundary Pollution and the Trade-Related Distortion of
Environmental Policy

- Important example:
 - greenhouse gas emissions and energy costs

Tangent: Carbon Leakage

- Unilateral action to reduce emissions by one country can cause emissions to rise from other countries:
 - shift in market share to more-polluting technologies
 - lower global prices for carbon-based fuels

Tangent: Abatement vs. Defense

- Abatement is subject to an externality problem
- The availability of defensive action exacerbates the problem

9.4 Trade, Transboundary Pollution, and the Distribution of Global Wealth

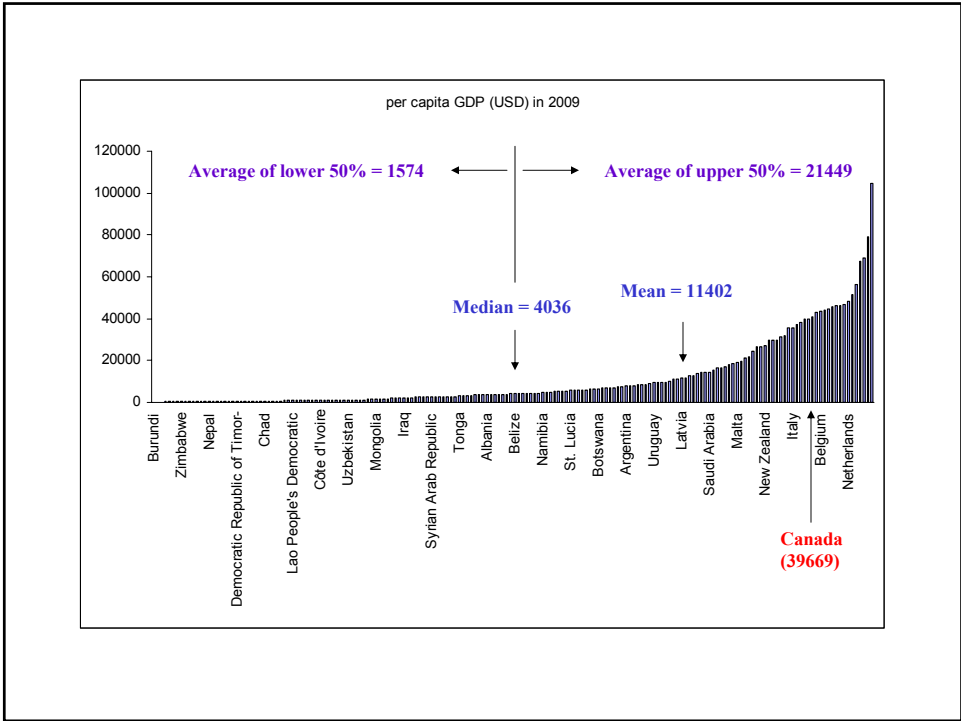

	rank	income
Luxembourg	1	80000
Norway	2	53000
Brunei	3	51000
United States	6	46000
Canada	12	39000
Mexico	54	14000
Brazil	78	9700
China	100	5300
India	129	2600
Afghanistan	176	733
Burundi	177	372
DR Congo	178	312

Trade, Transboundary Pollution, and the Distribution of
Global Wealth

- The key to resolving the distortion of environmental policy:
 - cooperation across countries.
- Such cooperation can be especially hard to achieve when countries differ in wealth levels.
- Why?

Trade, Transboundary Pollution, and the Distribution of
Global Wealth

- Better existing technology in rich countries means that abatement costs are higher in those countries than in poor countries; it is harder for rich countries to make additional improvements.
- Thus, efficient abatement - minimizing the overall abatement costs - requires relatively greater abatement from poor countries.

Trade, Transboundary Pollution, and the Distribution of
Global Wealth

- This means that efficient global abatement could actually make the poorer countries worse off.
- This scenario very likely applies to China, India and Brazil in the case of greenhouse gases.

Trade, Transboundary Pollution, and the Distribution of
Global Wealth

- How can we get these countries to participate under these circumstances?
 - explicit side payments
 - technology transfers

Trade, Transboundary Pollution, and the Distribution of
Global Wealth

- Limitations on the transfer of technology:
 - incentives for knowledge creation are eroded if the creator cannot capture at least some of the gains from its creation
 - ⇒ patents
 - strategic trade considerations and the desire to retain a competitive edge

Trade, Transboundary Pollution, and the Distribution of
Global Wealth

- The “solution”:
 - global cooperation and multilateralism

Example: Climate Finance

- Copenhagen 2010:
- \$100b per year (by 2020) commitment from rich countries to fund green initiatives in developing countries
- Spending so far in 2011: \$21b

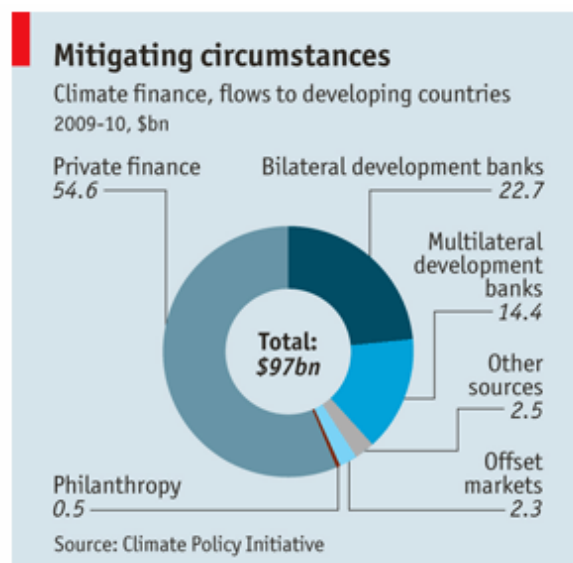

Tangent: Coalition Theory

- When is a cooperative treaty self-enforcing?
 - that is, when would all signatory countries prefer to remain in compliance with the treaty rather than defect?
- This may not be possible with universal membership
 - implication: unanimity goal under the current UNFCCC process is flawed

End

10. Economic Incentives, Environmental Regulation, and Trade

10.1 Introduction

Introduction

- This chapter provides a brief overview of environmental regulation.
- Our discussion will proceed as follows:
 - some general principles with respect to environmental policy design
 - three broad classes of policy instruments

Introduction

- potential impediments to the application of policy instruments
- the implications of trade and competitiveness considerations for the design of environmental policy.

Introduction

- The discussion here is only cursory.
- There is a vast body of knowledge on environmental policy design over which we will only skim.

10.2 General Principles for Environmental Policy Design

General Principles for Environmental Policy Design

- Two basic paradigms with respect to policy intervention in an economy:
 - the central planning paradigm soviet chinese style - restrict ind players
 - better – the regulated market paradigm demand orientated
- Our interest is in the second of these.

General Principles for Environmental Policy Design

- The regulated market paradigm:
 - resource flows are determined principally by ind players decentralized market forces - and the actions of firms and individuals that underlie those market forces - but those forces are regulated and shaped, to varying degrees, by policy intervention.

General Principles for Environmental Policy Design

- The policy problem:
 - to implement a resource allocation target as a corrected market equilibrium through the application of policy instruments to change the incentives of economic agents (firms and individuals).

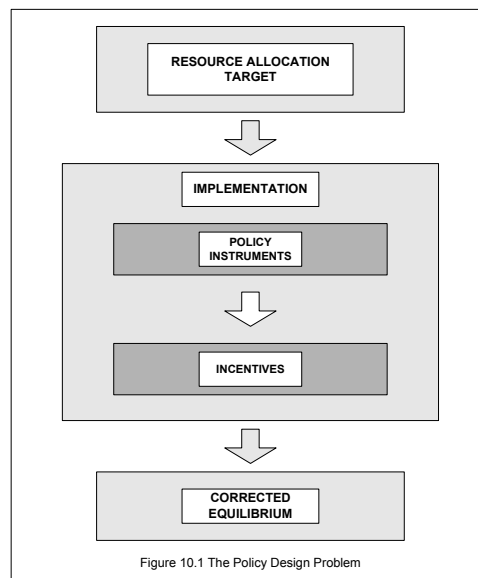

Figure 10.1 The Policy Design Problem

The Resource Allocation Target

- One element of the target is *economic efficiency* (or *Pareto efficiency*):
 - the target allocation should be such that it is *not* be possible to find an alternative allocation in which everyone in the economy (now and in the future) would be better off than in the target allocation.

The Resource Allocation Target

- Economic efficiency does not isolate a unique optimal resource allocation; many allocations can satisfy the efficiency criterion.
- The key difference between different efficient allocations relates to the *distribution of wealth* across individuals.

The Resource Allocation Target

- Thus, a resource allocation target must generally also have a distributional element; that is, some notion of “fairness” or ‘social justice’.
- The determination of “fairness” is not an economic issue, but a political one.

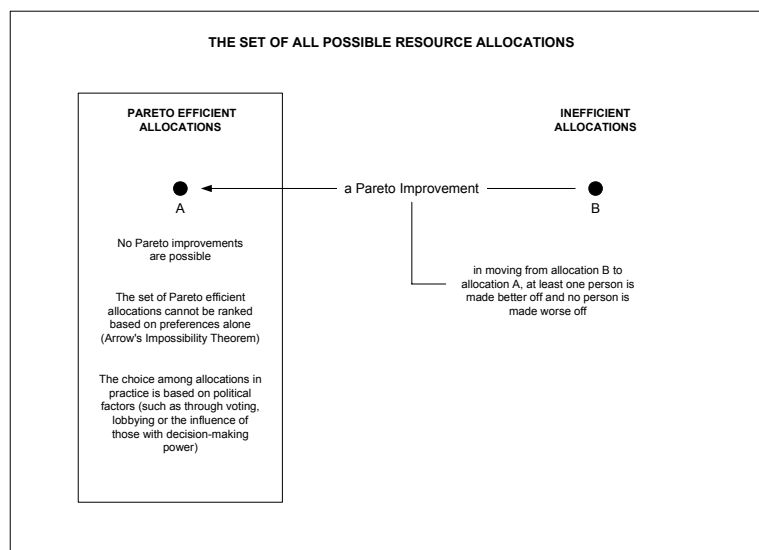

Figure 10.1A Pareto Efficiency and Resource Allocation

Tangent: Sustainability as a Target

- What is “sustainable development”?
- There are hundreds of definitions, all of them fuzzy. Example:
 - “development that meets the needs of the current generation without detracting from the ability of future generations to meet their own needs”.
 - World Commission on Environment and Development (1988)

Tangent: Sustainability as a Target

- A reasonable summary definition:
 - “living standards should not fall over time”
- Three questions to ponder:
 - what if “sustainability” is not feasible?
 - can we measure “aggregate natural capital”?
 - what if “sustainability” is not consistent with democratically expressed preferences of those currently alive?

Implementation of the Resource Allocation Target

- The next step in the policy design problem is to implement the chosen resource allocation target through the application of policy instruments.

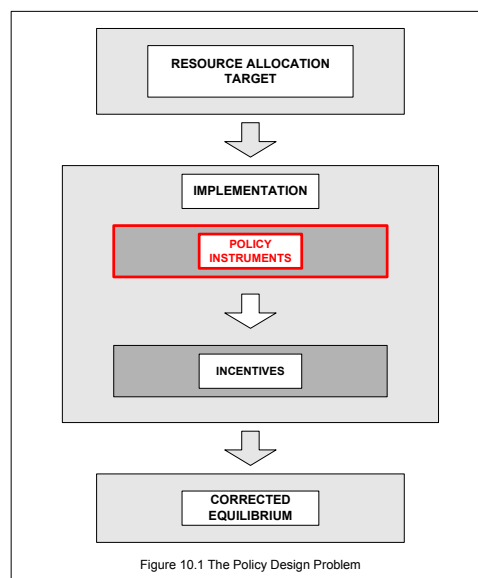

Figure 10.1 The Policy Design Problem

Implementation of the Resource Allocation Target

- The application of policy instruments is a two-tier process:
 - the choice of regulatory regime
 - the choice of instrument values

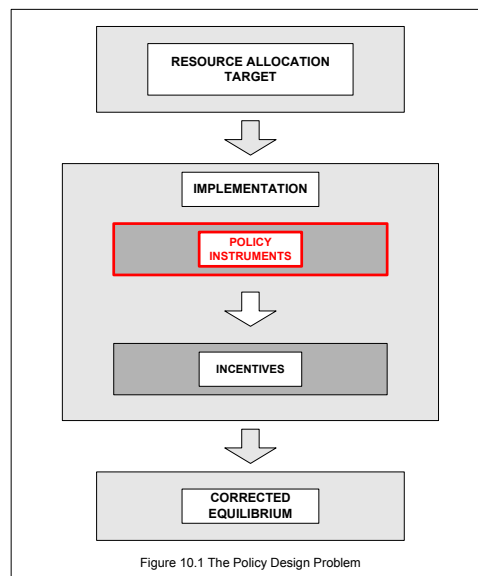
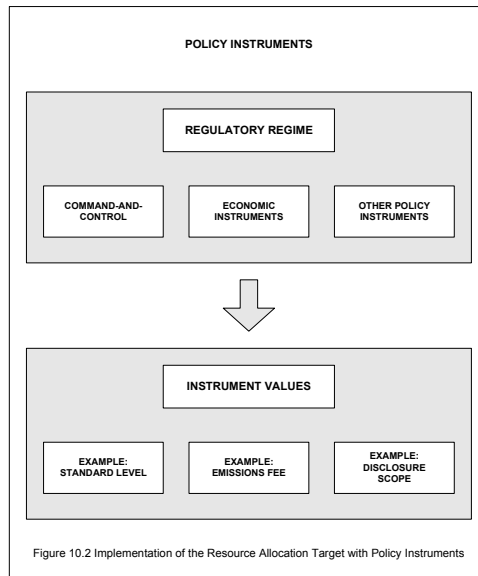

Figure 10.1 The Policy Design Problem



Implementation of the Resource Allocation Target

- An important principle in the use of instruments (regardless of the regulatory regime):
 - **the policy instrument should be targeted at the source of environmental damage**
- Example:
 - the mercury content of effluent vs. the volume of effluent itself; car ownership vs. car use

10.3 Command-and-Control Regulation

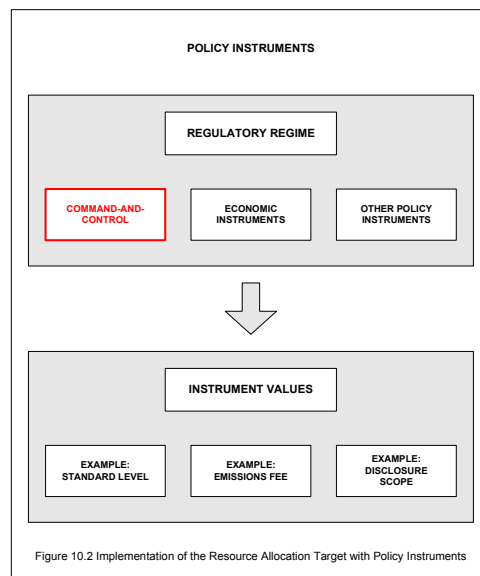

Command-and-Control Regulation

- The key characteristic of command and control (CAC) regulation:
 - the regulator specifies what individual firms can and cannot do, enforced by the threat of penalties for non-compliance
- Two main types of CAC regulation:
 - performance standards
 - design standards (or technology standards)

Performance Standards

- Performance standards place restrictions and conditions on the day-to-day performance of the regulated source (such as a factory or utility).

Tangent: Other Regulatory Areas with Performance Standards

- Speed limits
- Accounting practices
- Occupational health and safety standards

Performance Standards

- Various types of performance standards:
 - restrictions on emissions per unit time
 - restrictions on emissions per unit of output or input (sometimes referred to as “intensity” standards)
 - restrictions on the use of polluting inputs
 - mandated use of non-polluting inputs
 - restrictions on output

Performance Standards

- Among performance standards, emission standards are best, for two reasons:
 - emission standards give the regulated source more *flexibility* in meeting its target level of emissions and therefore allow it to choose the least-cost method for achieving its target
 - other types of standards can actually have *perverse effects* if not set very carefully

Performance Standards

- In general, performance standards should target the source of environmental damage as closely as possible.
 - If emissions are the source of damage then the standard should restrict emissions, and not some related variable, like emissions-per-unit-input or emissions-per-unit-output.

Performance Standards

- Targeting the source of damage can be difficult in some cases, especially for
 - non-point source pollutants
 - mobile source pollutants
- “Second best” policies may be necessary in those cases.

Design Standards

- Design standards (sometimes called technology standards) impose requirements for the use of particular pollution control equipment or a particular production technology.

Tangent: Other Regulatory Areas with Design Standards

- Safety standards for cars and aircraft
- Building codes for houses
- Safety standards for mines
- Training requirements for accreditation

Design Standards

- Design standards are often easier to monitor than performance standards and are therefore often preferred by regulators.
- Key cautionary point to bear in mind:
 - the mere existence of a cleaner technology does *not* necessarily mean that its adoption is worthwhile from a social perspective

Design Standards

- The social benefits of adopting a cleaner technology – in the form of reduced damage and reduced monitoring costs – must be weighed against the costs.
- An important part of that cost can be the foreclosure of an option to wait for the advent of even better technology.

Design Standards

- The adoption of cleaner technologies holds the long-term key to sustainable development but technology adoption decisions at any point in time must be based on sound cost-benefit analysis.

Tangent: Subsidies for Electric Vehicles

- Is this truly a “green” policy?
 - almost surely not
- Two effects of a subsidy:
 - a composition effect (a change in the mix of vehicles sold)
 - a consumption effect (an increase in overall vehicle sales)

Tangent: Subsidies for Electric Vehicles

- Composition effect has local air quality benefits but may lead to higher greenhouse gases depending on electricity source (eg. coal)

Uniform Standards and Cost-Effectiveness

- Command-and-control standards – of all types – have two major drawbacks:
 - generally not a cost-effective instrument for achieving aggregate emission targets
 - cost-effectiveness requires *non-uniform* standards based on relative abilities to reduce emissions but those abilities are usually unknown by the regulator
 - standards do not put a price on emission levels below the level of the standard

10.4 Economic Instruments

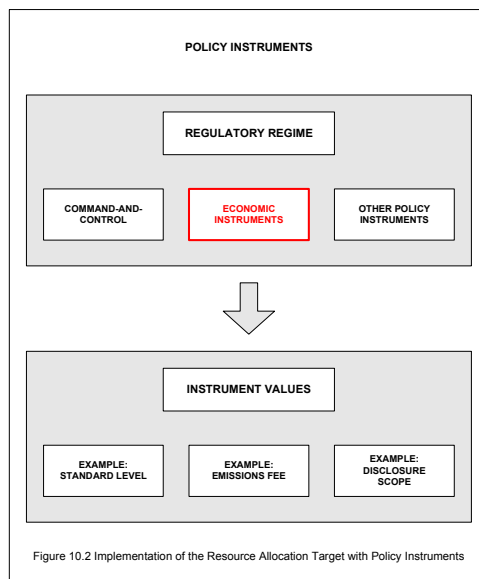

Economic Instruments

- “Economic instruments” (sometimes called “market-based instruments”) refers to a class of policy instruments that attach an explicit price to pollution.

Economic Instruments

- Economic instruments have a number of potential advantages over command-and-control instruments:
 - the creation of ongoing incentives for abatement and cleaner technology adoption
 - least-cost implementation of aggregate targets with fewer regulatory information requirements

Economic Instruments

- There are three main types of economic instrument, each of which puts an explicit price on pollution (either directly or indirectly):
 - emission fees
 - tradeable emission permits and tradeable emission reduction credits
 - deposit-refund type schemes

Emission Fees

- Emission fees directly assign an explicit price per unit of emissions.
- Example:
 - a fee of \$50 per ton of effluent solvent from an industrial plant

Tangent: Marginal Abatement Costs

- “Marginal abatement cost” refers to the cost of reducing emissions by one more unit.
- Key result in policy design theory:
 - the aggregate cost of achieving an aggregate emissions target is minimized when marginal abatement costs are equated across sources.

Tangent: Marginal Abatement Costs

- An illustrative example:
 - allocating emission reductions across two firms

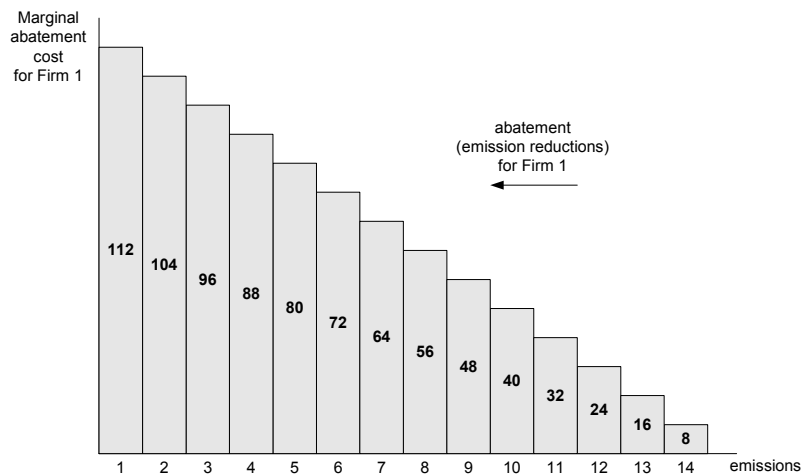

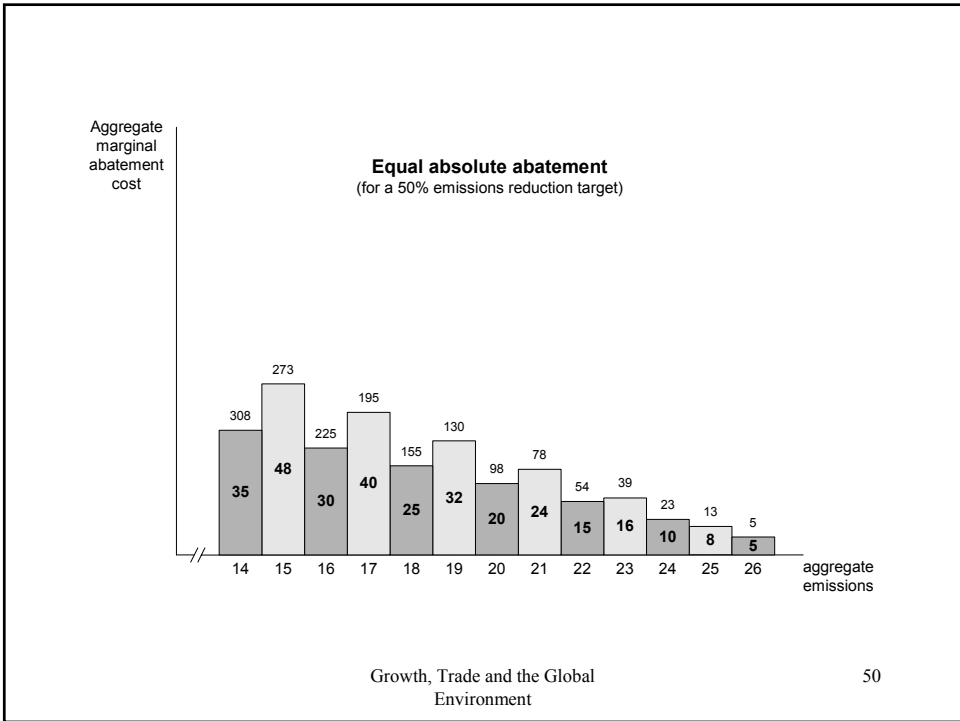
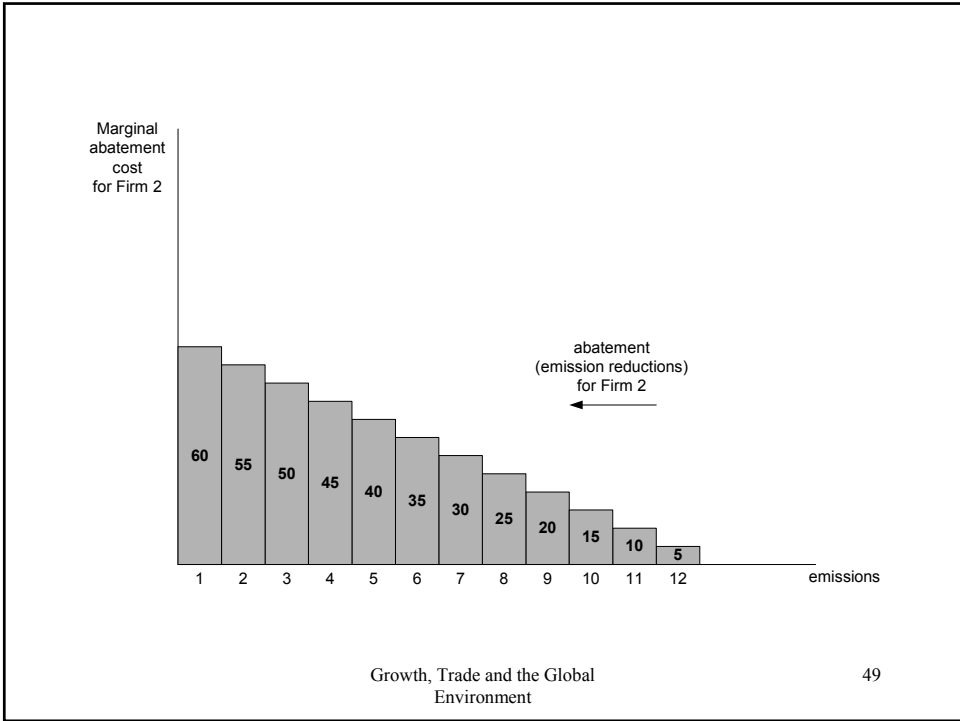

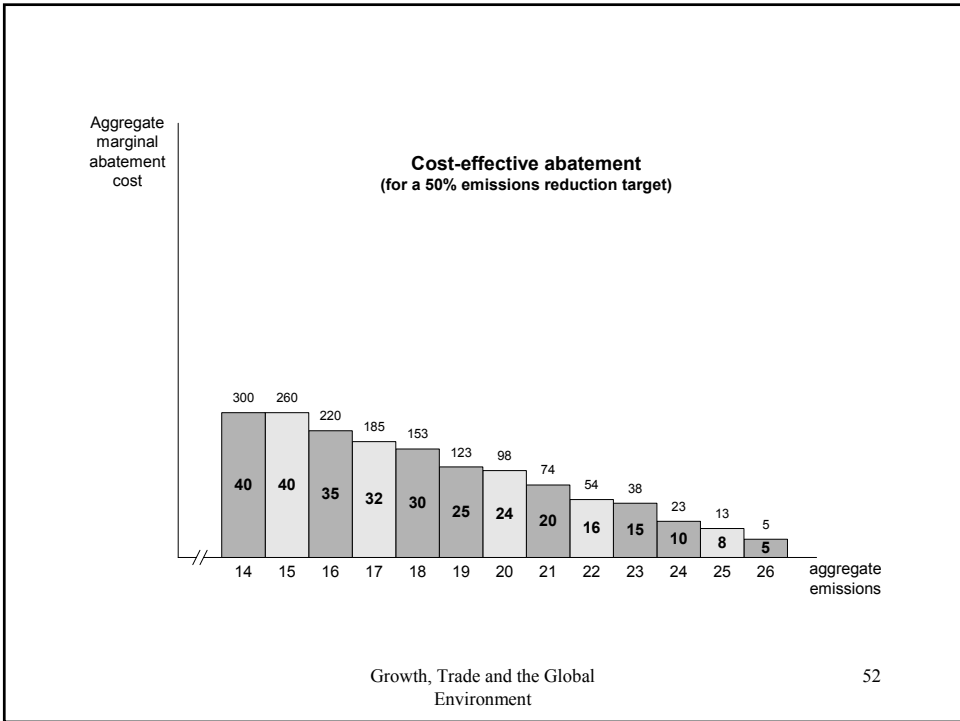
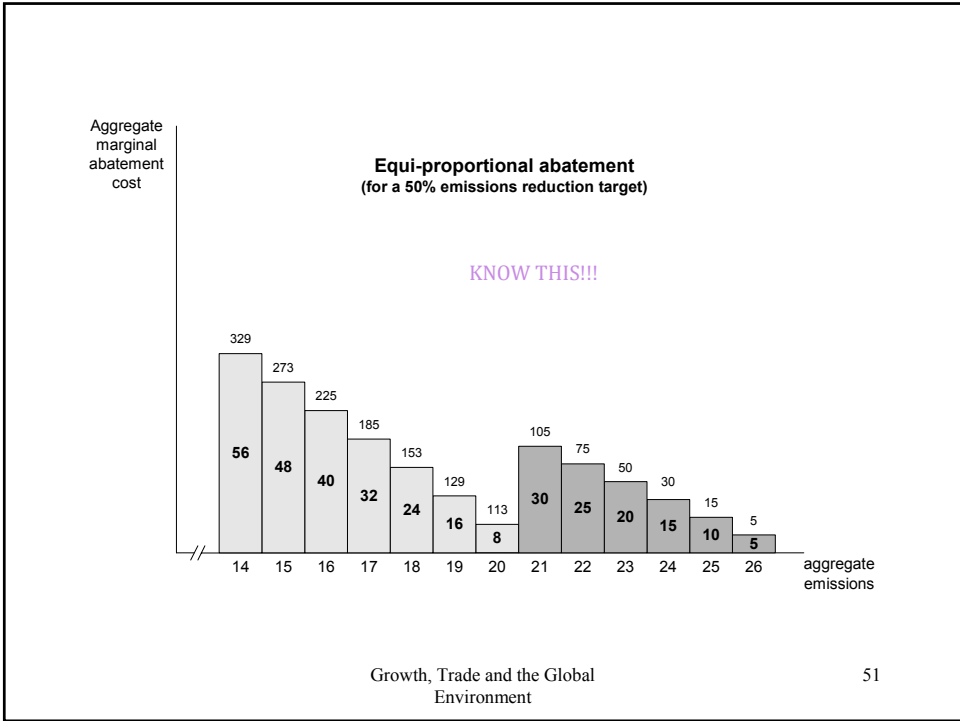

Tangent: Marginal Abatement Costs

- Is the Cost-Effective Solution Equitable?
- Cost-effective abatement (for a 50% reduction) requires:
 - abatement for firm 1: 5 units (36% reduction)
 - abatement for firm 2: 8 units (67% reduction)
 - abatement cost for firm 1: \$120
 - abatement cost for firm 2: \$180

Tangent: Marginal Abatement Costs

- Implementation via an Emissions Tax
- The emissions tax yields:
 - the cost-effective solution without direct centralized control
 - an equitable solution (the “pollutor pays principle”)

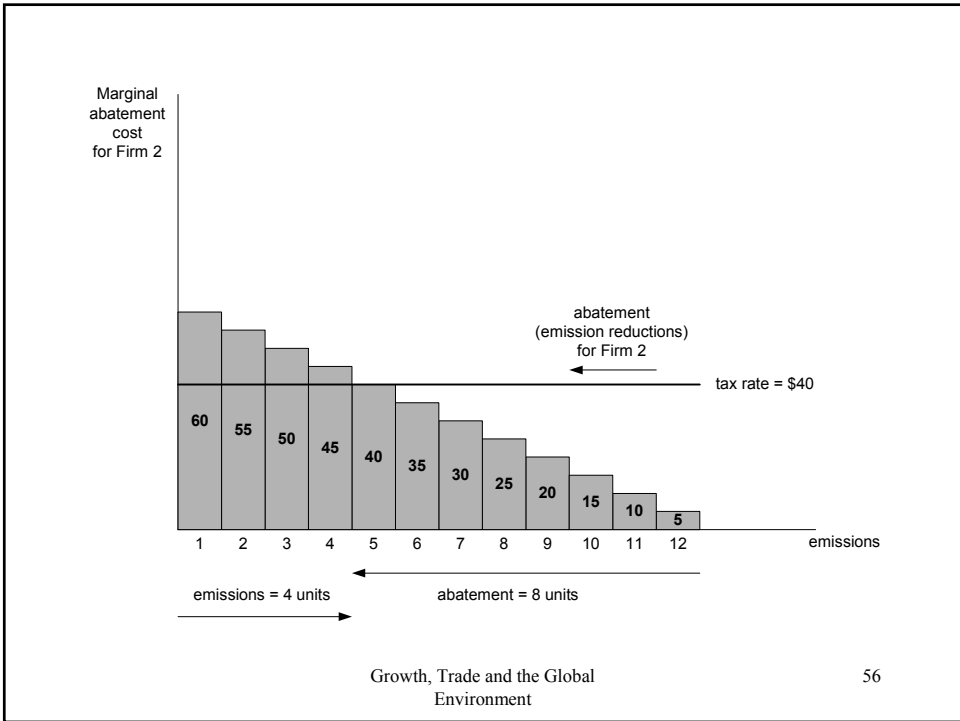
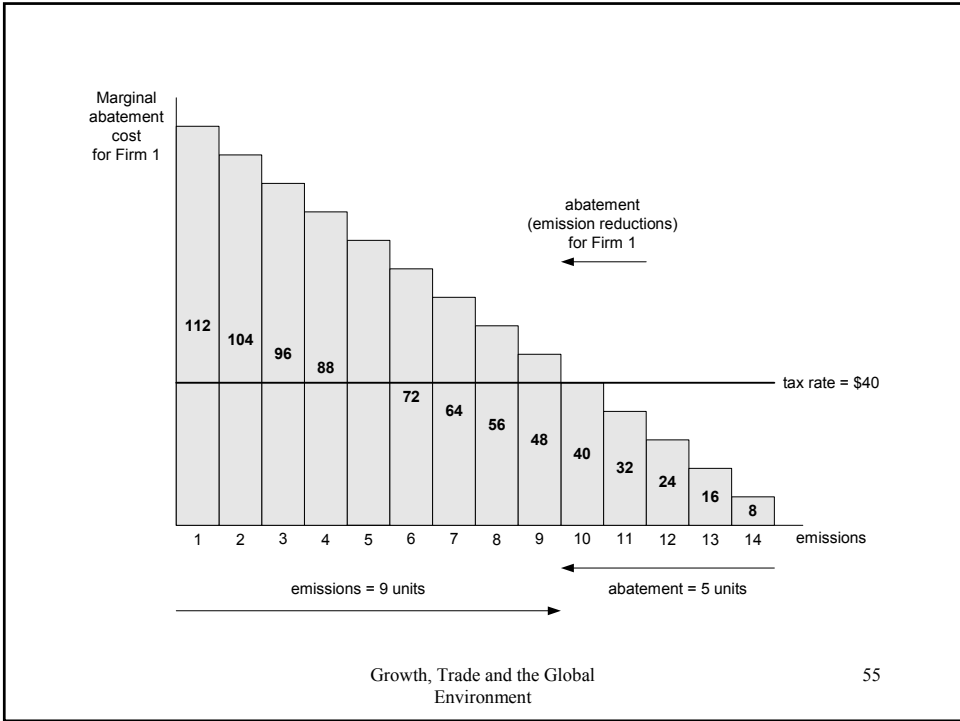

Tangent: Marginal Abatement Costs

- Cost Incidence under the Tax
- Firm 1:
 - abatement cost (for 5 units): \$120
 - tax payment (for 9 units): \$360
 - total cost for firm 1: \$480

Tangent: Marginal Abatement Costs

- Firm 2:
 - abatement cost (for 8 units): \$180
 - tax payment (for 4 units): \$160
 - total cost for firm 2: \$340

Emission Fees

- Emission fees can implement an aggregate emissions target at least cost because all sources face the *same* emissions price:
 - by each source finding the balance between its own marginal abatement cost and the emissions price, marginal abatement costs are indirectly brought into equality across sources.

Tangent: The BC Carbon Tax

- The BC carbon tax rises over time according to a pre-announced escalator:
 - 1 July 2009: \$15 per tonne of CO₂-equivalent
 - 1 July 2010: \$20 per tonne of CO₂-equivalent
 - 1 July 2011: \$25 per tonne of CO₂-equivalent
 - 1 July 2012: \$30 per tonne of CO₂-equivalent

Carbon Tax Rates by Fuel Type						
	Units for Tax Rates	July 1 2008	July 1 2009	July 1 2010	July 1 2011	July 1 2012
Liquid Fuels						
Gasoline	¢/Litre	2.34	3.51	4.68	5.85	7.02
Light Fuel Oil *	¢/Litre	2.69	4.04	5.38	6.73	8.07
Heavy Fuel Oil	¢/Litre	3.15	4.73	6.30	7.88	9.45
Aviation Fuel	¢/Litre	2.46	3.69	4.92	6.15	7.38
Jet Fuel	¢/Litre	2.61	3.92	5.22	6.53	7.83
Kerosene	¢/Litre	2.54	3.81	5.08	6.35	7.62
Naphtha	¢/Litre	2.55	3.83	5.10	6.38	7.65
Methanol	¢/Litre	1.09	1.64	2.18	2.73	3.27
Gaseous Fuel						
Marketable Natural Gas	¢/GJ** or ¢/M ³ ***	49.66 1.90	74.49 2.85	99.32 3.80	124.15 4.75	148.98 5.70
Raw Natural Gas	¢/M ³ ***	1.90	2.85	3.80	4.75	5.70
Propane	¢/Litre	1.54	2.31	3.08	3.85	4.62
Butane	¢/Litre	1.76	2.64	3.52	4.40	5.28
Ethane	¢/Litre	0.98	1.47	1.96	2.45	2.94
Refinery Gas	¢/M ³ ***	1.76	2.64	3.52	4.40	5.28
Coke Oven Gas	¢/M ³ ***	1.61	2.42	3.22	4.03	4.83
Solid Fuels						
Low Heat Value Coal	\$/Tonne	17.77	26.66	35.54	44.43	53.31
High Heat Value Coal	\$/Tonne	20.77	31.16	41.54	51.93	62.31
Coke	\$/Tonne	24.87	37.31	49.74	62.18	74.61
Petroleum Coke	¢/Litre	3.67	5.51	7.34	9.18	11.01
Combustibles						
Tires – shredded	\$/Tonne	23.91	35.87	47.82	59.78	71.73
Tires - whole tires	\$/Tonne	20.80	31.20	41.60	52.00	62.40
Peat	\$/Tonne	10.22	15.33	20.44	25.55	30.66

Growth, Trade and the Global Environment

61

Emission Fees

- The main drawback with emission fees relative to command-and-control standards is the difficulty of ensuring that the aggregate emissions target is achieved.
- This requires setting the right price in relation to abatement costs, about which the regulator usually does not have good information.

Growth, Trade and the Global Environment

62

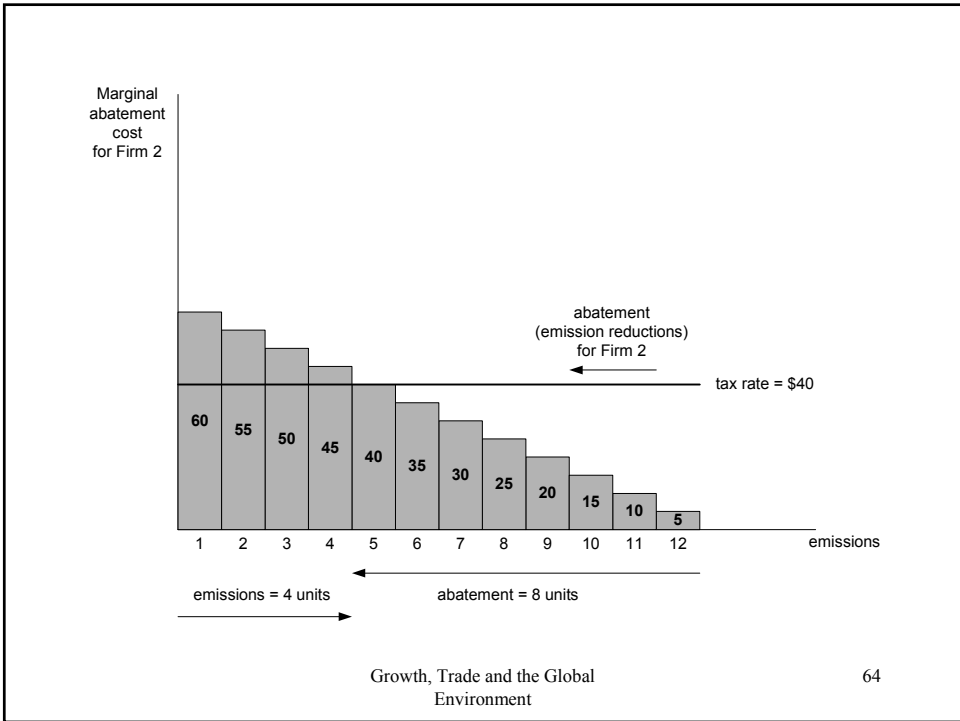
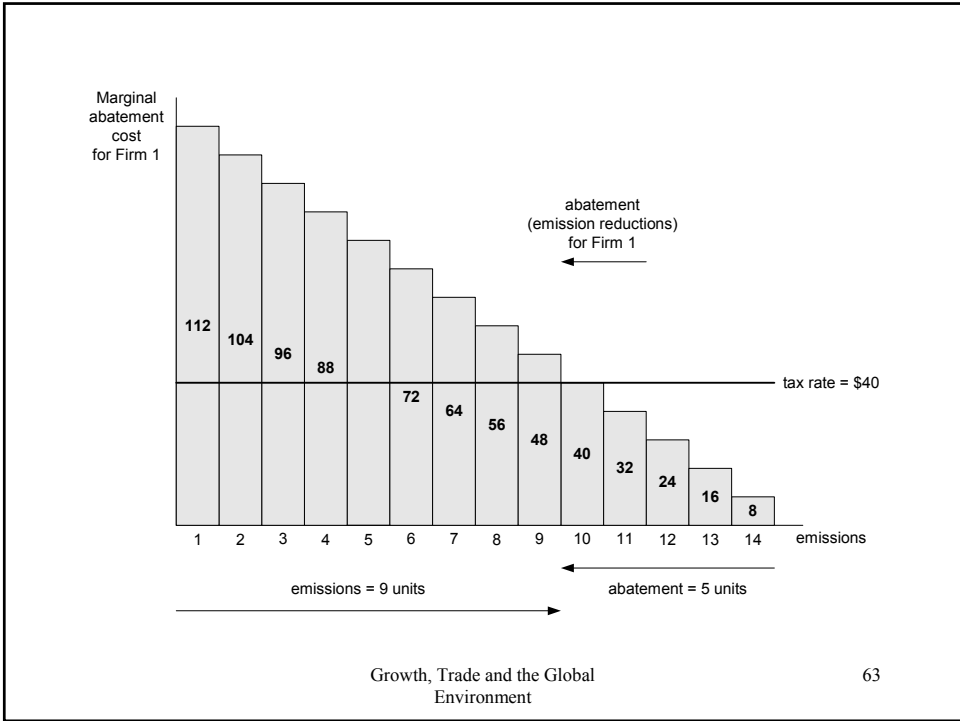

Emissions Trading

- Emissions trading can overcome the informational problem with emission fees.
- A tradeable emission permit scheme works as follows:
 - the regulator sets the quantity of aggregate emissions directly by assigning a specific number of permits

Emissions Trading

- permits can then be traded between emissions sources
- trading in the permit market creates a price for those permits
- all sources face the same market price for permits and this leads to the equalization of marginal abatement costs (and least-cost implementation of the aggregate target)

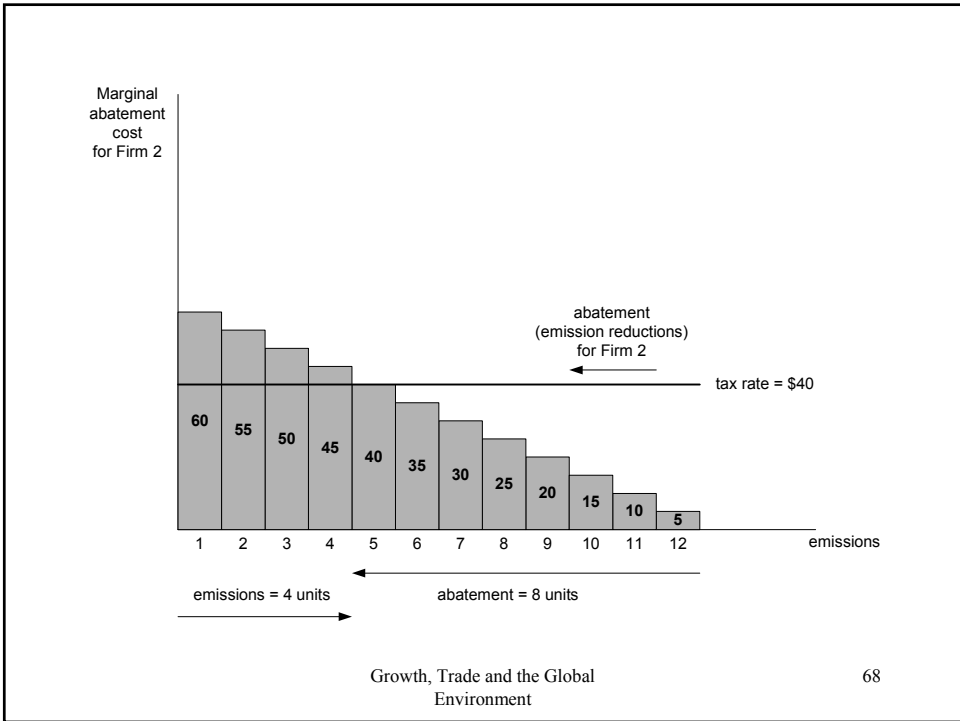
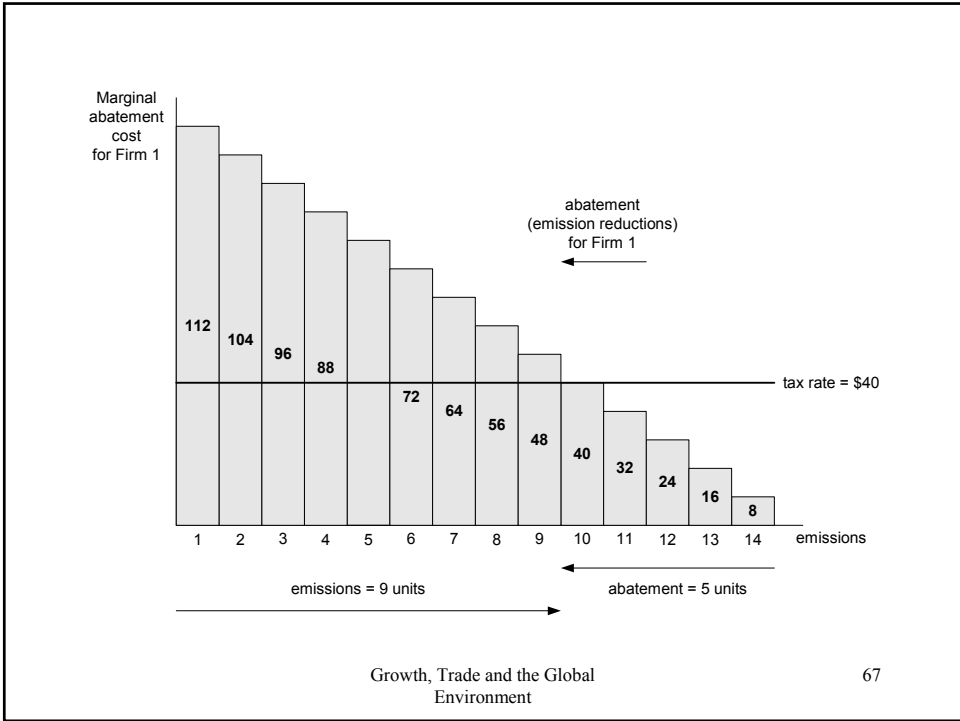

Emissions Trading

- Best example to date:
 - sulfur dioxide emissions trading in the US
- Scaled down versions of emissions trading that only allow one-to-one “trades” and “offsets” across sources, can also yield substantial cost savings in the implementation of an aggregate emissions target.

Deposit-Refund Schemes and Environmental Securities

- A deposit is added to the price a good (such as a beverage container) paid by the consumer upon purchase and refunded to the consumer if the waste product from the good is returned.
- It creates an incentive for the consumer to return the waste product rather than discard it as litter or send it to a garbage dump.

Deposit-Refund Schemes and Environmental Securities

- The deposit-refund scheme can be applied to a wide variety of goods, including
 - beverage containers
 - packaging
 - paints
 - used motor oils
 - car tires
 - exhausted batteries

Tangent: 100% Recovery?

- Should a deposit-refund scheme aim for 100% return rates?
- Generally not; the targeted return rate should balance costs and benefits.

Deposit-Refund Schemes and Environmental Securities

- *Environmental securities* are a variation on the deposit-refund scheme:
 - a security (or bond) is required before a risky activity is undertaken
 - the security is refunded only if no damage occurs
 - this creates incentives for precautionary action

10.5 Other Policy Instruments

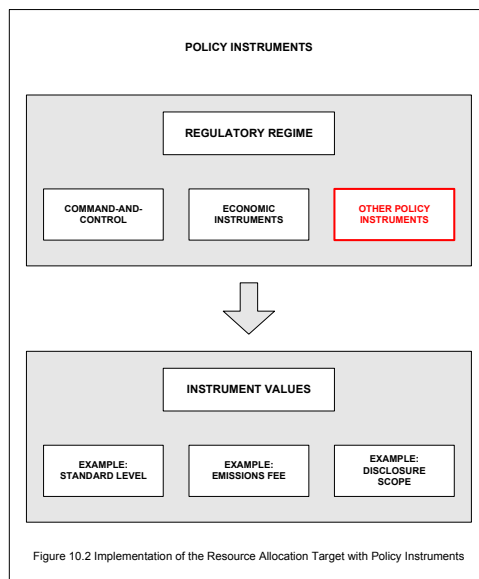

Other Policy Instruments

- Two other instruments worthy of note:
 - legal liability (under tort law)
 - information disclosure schemes (such as eco-labeling and certification programs)
- See text for further discussion.

Tangent: Tort Law

- **Common law** is the body of law established through legal precedents in the courts. different judges may have different responses
- **Civil (or statute) law** is the body of law written directly by a legislative body (such as Congress or Parliament).

however, judges unlikely to reject previous precedents - reasons may be different though

Tangent: Tort Law

- Within common law is a body of law known as **tort law**.
- A “tort” is a breach of duty (other than contractual duty), that has associated damages for which the perpetrator is liable under law. no written contract - yet expectations - tort law applies
- An agent damaged by a tort has a right to litigate (sue) the perpetrator.

Tangent: Tort Law

- Among the legal doctrines under tort law are: **nuisance** (such as being adversely affected by loud music from a neighbor); **trespass, negligence** (where the failure of the perpetrator to take “due care” in some action causes harm to another agent), and **strict liability**.

Tangent: Tort Law

- Under strict liability the source agent is liable for damages to the affected agent regardless of whether or not due care was taken.

Tangent: Information Disclosure Schemes

- Two types of disclosure
 - information about products
 - information about firms

Information about Products

- The disclosure of information about products is meant to shift consumer demand away from environmentally damaging products and product brands.
- Information policies of this type include
 - product-class information campaigns
 - certification and eco-label programs

Information about Products

- **Eco-label and certification programs** allow producers to attach a standardized label or symbol to their products if they have been certified as having satisfied certain conditions with respect to the environmental profile of the product.

Information about Products

- The main positive attributes of a government-sponsored eco-label program are
 - ease of recognition by the consumer reduces the costs of information acquisition
 - consumer confidence in the validity of the environmental claims is often buoyed by the formal government endorsement.

Information about Products

- Eco-label programs have two main limitations:
 - high recognizability relies on common usage which means the “environmentally friendliness” criterion cannot be set too high
 - the specificity of the environmental impacts of different products limits the general applicability of the eco-label.



Information about Firms

- The disclosure of information about the environmental profile of firms is targeted at three audiences:
 - green consumers who might boycott the products of a “black-marked ” firm
 - green (or “ethical”) investors
 - investors who expect a link between information disclosure and future profitability.

Information about Firms

- The release of “negative” environmental information about a firm signals two things that could adversely affect profitability:
 - a possible shift in consumer demand
 - the prospect of tighter (and costlier) standards or enforcement.
- The release of “positive” information is likely to have the opposite effect.

Information about Firms

- What is the effect of information release?
- There is some evidence for an impact on stock prices of highly polluting firms after the publication of the US toxics release inventory (TRI).

Information about Firms

- However, this stock price effect appears to be short-lived.
- This suggests that investors are more concerned with the possible impact that information may have on profitability than with the information *per se*; stock prices recover if no profitability impact materializes.

10.6 Impediments to the Application of Policy Instruments

Impediments to the Application of Policy Instruments

- Two main impediments to the application of environmental policy instruments:
 - political obstacles
 - monitoring and enforcement costs

Political Obstacles

- There are many political obstacles.
- Our focus here is on just one:
 - equity considerations

Political Obstacles

- It is sometimes argued that uniform standards are a “fairer” form of policy instrument than economic instruments because the explicit pricing of pollution means that the relatively wealthy are able to pollute more.

Political Obstacles

- Two responses to this critique of economic instruments:
 - the inefficiency associated with uniform standards (that is, the higher-than-necessary aggregate cost of meeting a given pollution target) means that resources are being wasted that could otherwise potentially have been devoted to improving the lot of the poor

Political Obstacles

- economic instruments ensure that all agents - including relatively wealthy polluters - pay a price for the environmental damage their own activities cause.
 - In contrast, the cost of achieving an environmental quality target under uniform standards is often spread across rich and poor arbitrarily.
 - Examples: water rationing versus water pricing; insulation standards versus electricity pricing

Monitoring and Enforcement Costs

- No environmental regulation is effective if the regulated agents do not comply with it.
- Fostering compliance generally requires monitoring and enforcement (M&E), and M&E is costly.

Monitoring and Enforcement Costs

- The design of M&E policy is an important determinant of its cost.
- Two points to consider here:
 - polluters respond to the magnitude of the *expected penalty* for non-compliance
 - the expected penalty is the actual penalty weighted by the probability of being discovered in non-compliance

Monitoring and Enforcement Costs

- *self-reporting* can be a valuable part of M&E policy
 - the key is to set modest fines for non-compliance (to encourage the reporting of spills, etc.) but large fines for false reporting

10.7 Trade, Competitiveness, and the Choice of Environmental Policy Instruments

Trade, Competitiveness, and the Choice of Environmental
Policy Instruments

- A key feature of economic instruments is their potential to be more cost-effective in implementing environmental quality goals than command-and-control policies.
- That feature of economic instruments becomes even more important when the policy problem is framed in a trade context, due to competitiveness considerations.

Trade, Competitiveness, and the Choice of Environmental
Policy Instruments

- Two issues of importance:
 - economic instruments, when applied in concert with the polluter pays principle, can raise government revenue that would otherwise have to be raised through more conventional distorting taxes, such as income taxes.
 - shifting away from these taxes in favour of environmental taxes can actually enhance competitiveness

Trade, Competitiveness, and the Choice of Environmental
Policy Instruments

- different policies have different implications for
the *incidence* of the cost of pollution abatement

End

11. Topics on the Economy & the Environment: Biodiversity

11.1 What is Biodiversity?

- **Biodiversity** (or biological diversity) refers to the number and variety of living organisms.
- Three different levels of biodiversity:
 - genetic diversity
 - species diversity
 - ecosystem diversity

What is Biodiversity?

- Genetic diversity:
 - variety of genetic information in all living organisms
- Species diversity:
 - variety of species
- Ecosystem diversity:
 - variety of ecological processes or habitats

What is Biodiversity?

- There is no universally accepted precise definition of biodiversity.
- This is due partly to:
 - the complexity of the issue; and
 - an “index number problem”: the choice of index for measuring any multi-faceted entity depends on what aspects of it are deemed most valuable.

11.2 Threats to Biodiversity

- The main threat to biodiversity is the destruction of tropical rainforests.
- Tropical rainforests are thought to hold between 50 and 90 percent of all species on earth, including 65 percent of vascular plants and up to 96 percent of insects.

Threats to Biodiversity

- Only a small percentage of these species have been catalogued: around 1.4 million out of the estimated 10 million species on earth.
- Thus, much of the concern over the loss of biodiversity arises from the fact that we do not even know what we are losing.

Threats to Biodiversity

- The extinction of species is not a new or unnatural phenomenon - there have been many mass extinctions throughout earth's history - but the current rate of human-induced species extinction is extremely high.
- At current deforestation rates, vast numbers of species will be lost over the next century.

11.3 The Biodiversity Policy Challenge

- The economic approach to biodiversity policy is one based on balancing costs and benefits:
 - on one hand: biodiversity is valuable and its loss has associated costs for society;
 - on the other hand: activities like timber harvesting, agriculture, industrial development, etc. also have value.

The Biodiversity Policy Challenge

- The benefits of damaging activities may sometimes outweigh the costs of the associated biodiversity loss and should be allowed to proceed.
- In other instances those benefits will not be high enough to justify the biodiversity loss.

The Biodiversity Policy Challenge

- The policy challenge:
 - to strike an optimal balance between the conservation of biodiversity and the pursuit of other development goals.

The Biodiversity Policy Challenge

- Meeting that challenge raises two key issues:
 - How should we value biodiversity?
 - What measures can be implemented to ensure those values are taken into account in resource allocation choices?

11.4 The Economic Value of Biodiversity

- The total economic value of any environmental resource can be decomposed conceptually into separate components:
 - use value; and
 - passive use (or “non-use”) value

The Economic Value of Biodiversity

- **Use value** comprises the value attached to “sensuous interaction” with the environmental resource or the ecological services it provides.

The Economic Value of Biodiversity

- Biodiversity provides a wide array of ecological services that support human life and happiness. For example:
 - the resilience and adaptability of ecosystems;
 - the efficiency of nutrient storage and recycling;
 - insurance against the risk of disease and pestilence in agriculture;

The Economic Value of Biodiversity

- the development of new food types, cosmetics and medicines;
- soil protection;
- water runoff regulation;
- pollution breakdown and assimilation;
- recreation and ecotourism.

The Economic Value of Biodiversity

- **Passive use** value refers to values that arise from the protection of a resource even if the resource is not actively used.
- Passive use value comprises three elements:
 - option value
 - bequest value
 - existence value

The Economic Value of Biodiversity

- **Option value** is the value of retaining the option to make active use of biodiversity in the future.
- An important example is the value of preserving biodiversity for the future development of medicines to fight hitherto unknown diseases.

The Economic Value of Biodiversity

- **Bequest value** is the value attached to conserving biodiversity for future generations.

The Economic Value of Biodiversity

- **Existence value** is the value attached to the continuing existence of biodiversity, independent of any potential use it might serve, either now or in the future.
- For example, many people attach a value to the survival of a variety of whale species in the wild even if they will never see one.

The Economic Value of Biodiversity

- The collective value of the earth's ecosystems is probably infinite: humans would not survive without them.
- More important from an economic perspective is the valuation of **marginal changes in biodiversity**: what is the value lost when a species becomes extinct or a unique ecosystem is lost?

The Economic Value of Biodiversity

- These values are needed to determine the optimal balance between the conservation of biodiversity and the pursuit of other valuable activities - such as forestry or industrial development - that might cause a loss of biodiversity.

11.5 Biodiversity: An Economic Framework

- To value marginal changes in biodiversity we need a framework for thinking about how an individual species or individual ecosystem contributes to diversity.
- That is, we need to ask: what is diversity?

Biodiversity: An Economic Framework

- We will focus on a framework developed by Andrew Metrick and Martin Weitzman (1998).
- The Metrick-Weitzman framework is imperfect (for reasons to be discussed later) but it provides a useful starting point.

Biodiversity: An Economic Framework

- The Metrick-Weitzman framework is couched in terms of species diversity but we can also apply the framework at the level of ecosystem diversity.

Biodiversity: An Economic Framework

- Think of a species as a library, whose books represent the genes of that species.
- The book collections in different libraries overlap to some extent – in the same way that different species share some of the same genes – but the overlap is not complete.

SPECIES 1			SPECIES 2			SPECIES 3		
A2	A5	A9	A3	A7	A8	A1	A4	A6
B3	B6	B9	B1	B4	B7	B2	B5	B9
C1	C7	C9	C2	C4	C10	C3	C5	C6
D2	D8	D10	D3	D8	D9	D1	D4	D7

Biodiversity: An Economic Framework

- The value of a species has two components:
 - the direct value of the species itself (both use and passive use values); and
 - the value of the genetic information embodied in it (both use and passive use values)
- In the library analogy: the library building itself has value and so too does its collection of books.

Biodiversity: An Economic Framework

- Measuring the direct value of the species is relatively straightforward (at least conceptually).

Biodiversity: An Economic Framework

- The more difficult conceptual problem is measuring the value of the genetic information embodied in the species, especially given that some of that information also resides in other species.
- The key is to determine the distinctiveness of that information.

Biodiversity: An Economic Framework

- We can think of distinctiveness in terms of **evolutionary distance**.
- Think of a species as arising from an evolutionary branching process, as illustrated by the evolutionary tree for six species of primate in the next slide.

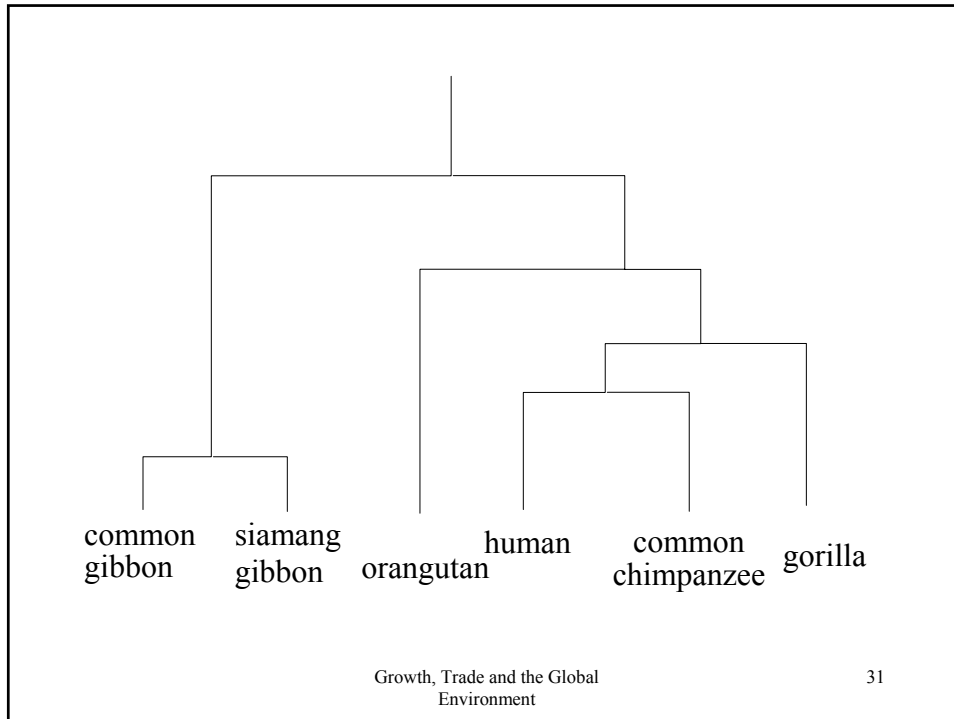



Biodiversity: An Economic Framework

- The two most closely related (in terms of greatest genetic overlap) are the two species of gibbon; they became separated from each other relatively recently along the evolutionary path.

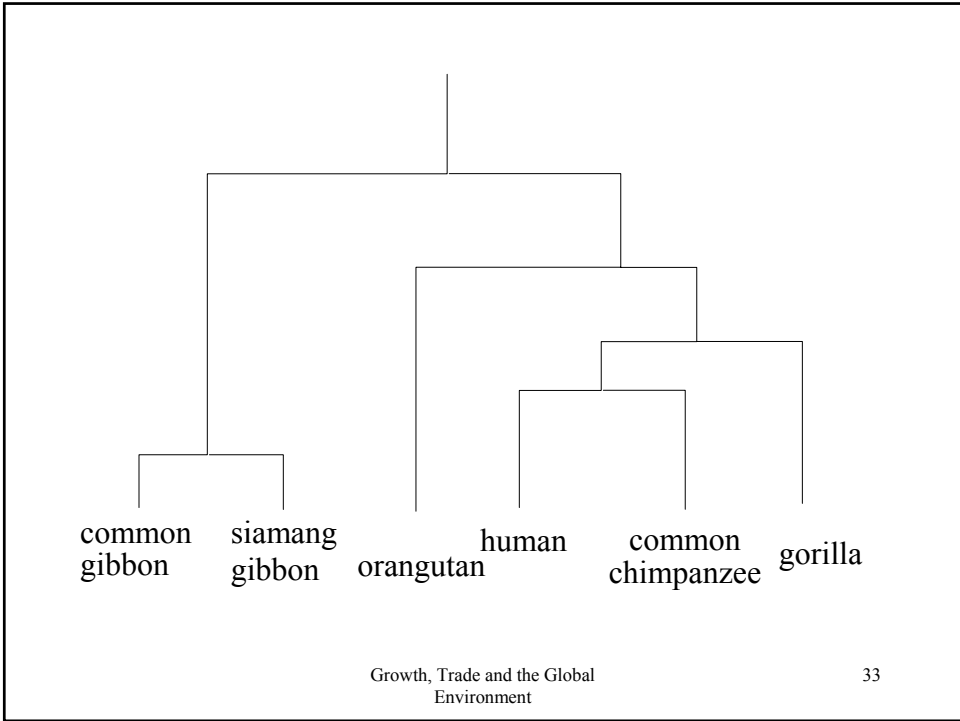
Growth, Trade and the Global Environment 32

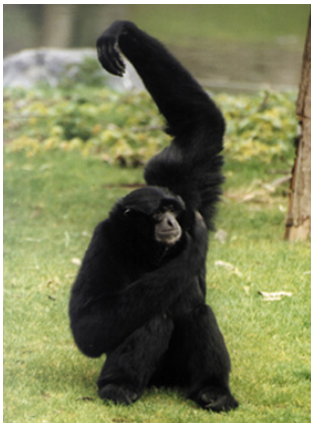

Biodiversity: An Economic Framework

Growth, Trade and the Global Environment 34

Biodiversity: An Economic Framework

- The smallest loss of genetic information from a single species extinction among these six primates would occur if one of the two species of gibbon was lost.

Biodiversity: An Economic Framework

- However, if both species of gibbon were lost, a whole evolutionary line would be lost, and there would be a significant loss of biodiversity.

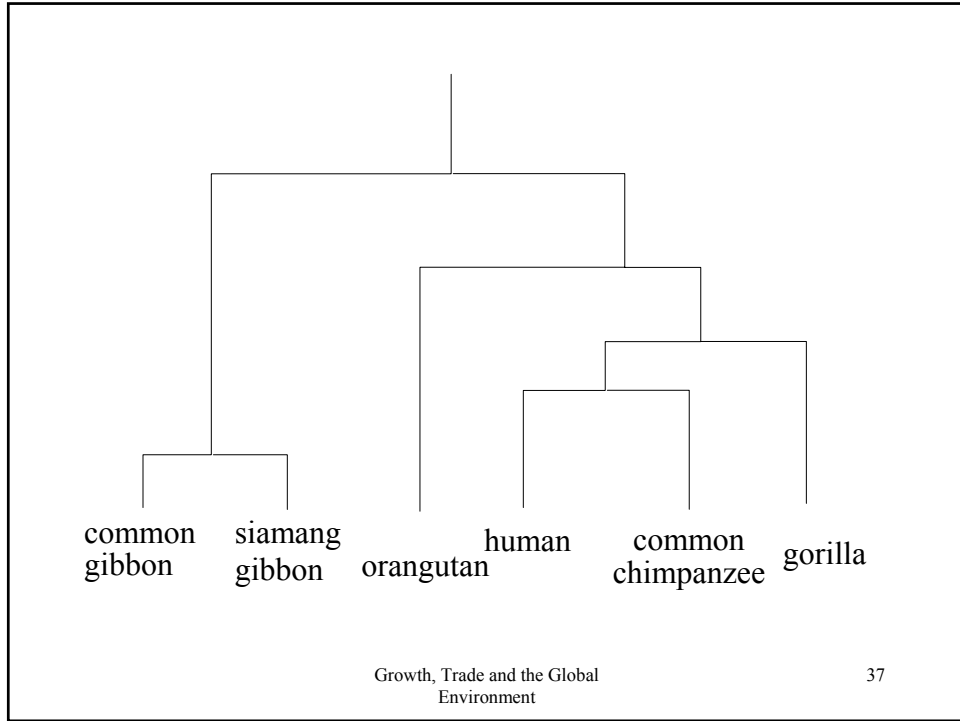

Biodiversity: An Economic Framework

- Thus, the value of any one species depends critically on the extinction risk faced by genetically similar species.

Growth, Trade and the Global Environment 38

Biodiversity: An Economic Framework

- An optimal conservation strategy in the primate example might be to devote relatively few resources to protecting the common gibbon if the siamang gibbon is reasonably safe.
- Conversely, the common gibbon might warrant strong protection if the siamang faces a high risk of extinction.

Biodiversity: An Economic Framework

- In general, the distinctiveness of a species can be represented by the length of its evolutionary branch off the rest of the tree.
- Under some conditions, a measure of diversity can be defined in terms of the total length of all vertical branches on the tree.

Biodiversity: An Economic Framework

- Now let us apply this framework to the problem of ranking different species (or ecosystems) in terms of their biodiversity value.
- This will not give us dollar values for biodiversity - that requires a lot more steps - but it can provide a conceptual framework for setting conservation priorities.

Biodiversity: An Economic Framework

- Weitzman shows that if our objective is to maximize the total value of biodiversity - the direct value of species plus the value of their genetic information - then conceptually the solution is to rank species according a **preservation index (PI)**.

The Weitzman Preservation Index

$$PI_i = [D_i + U_i] \left[\frac{\Delta S_i}{C_i} \right]$$

D_i = distinctiveness of species i

U_i = direct value of species i

ΔS_i = change in probability of survival if
protected

C_i = cost of protecting species i

Biodiversity: An Economic Framework

- The PI ranks species in order of their biodiversity value (direct value plus diversity value) per dollar of cost, weighted by the increase in their probability of survival through protection.
- Quantifying each of these four variables is not easy; more work is needed in the area.

Biodiversity: An Economic Framework

- However, the framework points to four key factors to consider in the design of a conservation strategy:
 - the genetic distinctiveness of a species
 - the direct value of a species
 - survival probability with protection
 - the cost of protection

Biodiversity: An Economic Framework

- These same four considerations also apply at the ecosystem level but the problem of defining distinctiveness at the ecosystem level is an order of magnitude more complex.

End