Laboratory 2 – Units, Dimensions & Significant Figures
Assigned Week of September 24-28, 2012
Due October 1-4*, 2012
(*see Section V for important details on submission and dates)

I — Introduction:

We often become annoyed when we have to make tedious conversions between various units. At times, it seems so unbearable that a question comes to mind: why do we bother with units anyway? And why do textbook problems keep giving quantities first in pounds and then in kilograms (or worse, in both!)? An interesting and instructive Canadian case study comes to mind, where passengers of Air Canada’s flight 143 learned the importance of units the hard way.

On July 23, 1983, twelve kilometres above the Manitoba countryside, the unthinkable happened: a brand new Air Canada Boeing 767-200, flying from Montreal to Edmonton, ran out of fuel. The 120 tonne, \$40-million aircraft became a glider, dropping at over 600 metres per minute with no hope of reaching the closest city airport, which was in Winnipeg. Amazingly, the powerless aircraft made a successful emergency landing at an abandoned airbase in Gimli. The incident became so famous, that the aircraft was given a nickname – the “Gimli Glider”. In fact, in Western Canadian slang, “to pull a Gimli Glider” is to make a spectacular foul-up. So what really happened? How could a modern jetliner, equipped with the latest technology and piloted by skilled people, run out of gas at 26 000 feet? There was no fuel leak or engine malfunction. The hard truth is that the ground crew simply did not put enough fuel into the aircraft before it departed. Let’s see how this happened.

A Boeing 767 is normally fuelled using a device known as the Fuel Quantity Information System Processor (FQIS), which operates all of the internal pumps and reports to the pilots on the status of the fuel load. However, Flight 143’s FQIS was not working properly, and instead, the fuel load was measured with an aircraft dipstick. The maintenance worker, who found that the fuel gauge did not work on ground inspection, incorrectly assured the pilot that the aircraft was certified to fly without the functioning gauge if the crew checked the fuel tank levels regularly. Crew members measured the 2 fuel tank levels at 62 cm and 64 cm. This corresponded to 3 758 L and 3 924 L for a total of 7 682 L according to the aircraft’s manual (notice that at the time the Canadian government was painfully introducing the metric system nationwide). The ground crew knew that the flight required 22 300 kg of fuel. The problem they faced was: with 7 682 L of fuel on the aircraft, how many more litres were needed to make the total 22 300 kg of fuel? One crew member informed the other that the “conversion factor” (being the fuel density) was 1.77. So it was calculated that the aircraft needed an additional 4 917 L of fuel for the flight. The crucial fault was that no one ever questioned *what were the units of the conversion factor*. Thus, the ground crew’s calculations were:

$$7\,682\text{ L} \times 1.77 = 13\,597\text{ kg of fuel on board}$$

$$22\,300\text{ kg needed} - 13\,597\text{ kg on board} = 8\,703\text{ kg to be added}$$

$$8\,703\text{ kg} / 1.77 = 4,916\text{ L of fuel to be added}$$

The metric changeover in Canada should have been accompanied by further education on the airline's part. The "conversion factor" of 1.77 was actually the fuel's density in *pounds* per litre, not kilograms. The fuel's density in kilograms per litre was actually 0.803. The ground crew should have computed the following:

$$\begin{aligned}7\,682\text{ L} \times 0.803\text{ kg/L} &= 6\,169\text{ kg of fuel on board} \\22\,300\text{ kg needed} - 6\,169\text{ kg on board} &= 16\,131\text{ kg to be added} \\16\,131\text{ kg} / 0.803\text{ kg/L} &= 20\,163\text{ L of fuel to be added}\end{aligned}$$

The bottom line is that by not accounting for the units in the density of the fuel, the ground crew added 4 916 L of fuel to an aircraft that needed 20 163 L of fuel and nearly killed more than 60 people! Units are important!!

It is absolutely essential to understand the concepts of dimensions, dimensional measurements, significant figures and unit systems before the fundamental tools—mathematics and physics—can be applied to an engineering situation. The fundamental meaning of a dimension was introduced in class. In addition, dimensional measurements and significant figures were discussed. Finally it was pointed out that there is more than one primary unit system used to quantify engineering measurements based on mathematical equations. While the *Système Internationale (SI)* is preferred, the gravitational system (otherwise known as *FPS*) and the hybrid American system are still very much employed in the engineering world. Therefore you will have to be familiar with all three systems in your professional lifetime. These are all brought together in this laboratory exercise.

IntelliCAD: You are going to need to do some software sketching in this laboratory exercise and you will need some experience in this regard. You will become familiar with the sketching capabilities of a computer aided drafting (CAD) system called IntelliCAD, which is similar to AutoCAD.

In this laboratory exercise, you are asked to produce some sketches in support of the calculations for your report. IntelliCAD sketching is not just used in this laboratory; it will be used as a general sketching tool in support of laboratory exercises to come later, and it will also be used for producing engineering drawings near the end of this course.

II — Problem Statement:

Part 1: The efficiency η of a pump is defined as the (dimensionless) ratio of the power developed by the flow to the power required to drive the pump:

$$\eta = \frac{Q\Delta P}{\text{input power}}$$

where Q (with dimensions of volume/time) is the volume flow rate and ΔP is the pressure increase produced by the pump. In turn, Q can be calculated as the product of the cross-sectional area (A) for flow and the average flow velocity (v_n) perpendicular to that area ($Q = v_n A$).

You are given three different pumps to analyse for efficiency:

1. **Pump 1** has an input power is 16 HP (horsepower). It develops a pressure increase of 35 lbf/in² when its flow rate is 2.1## m³/min, where ## is to be replaced by the last two digits of your student number (e.g. for 10022245, ## is 45, for 10022100, ## is 00)
2. 267 kW of power is supplied to **Pump 2**. This allows it to raise the pressure of a flow, traveling at an average velocity of 11,811 in/min through a 1.00 m by 1.00 m rectangular cross-sectional area, from 760 mm of Hg (millimetres of mercury) to 915 mm of Hg.
3. A flow is pumped at a rate of 55 061 US gal/hr (United States gallons per hour) through **Pump 3**, which is supplied with 29 041 Btu/hr, and which raises the pressure from 15 psi to 2 atm (two atmospheres).

Unfortunately, each pump's performance characteristics are presented in all three unit systems – SI, FPS and with US units – which makes comparisons difficult. You are asked to rank these pumps in terms of efficiency according to their η values expressed in %.

Note: A table of conversion factors is given at the end of this document. A number of software tools to convert units can also be found (many freely available) on the Internet. However, good engineering practice is to use tools only if you know you can trust them.

Part 2: In order to become familiar with basic IntelliCAD operation, read Chapter 15 in your textbook; follow the instructions to generate Figure 15.25 in the textbook.

Part 3: Imagine that a particular mechanical device contains three different steel alloy components, shown in isometric view in Figures 1, 2 and 3. In order to protect these components from corrosion, the components are to be covered with an expensive coating. To determine the amount and cost of the coating, the total surface area must be calculated first. The surface areas can be readily calculated from sketches done in IntelliCAD with the 'area' command, after dimensioning each component's three primary views: top, front and side. You are to produce the working (detail) drawings and calculate the surface area of each component. (In addition, you will report the volume of each component.)

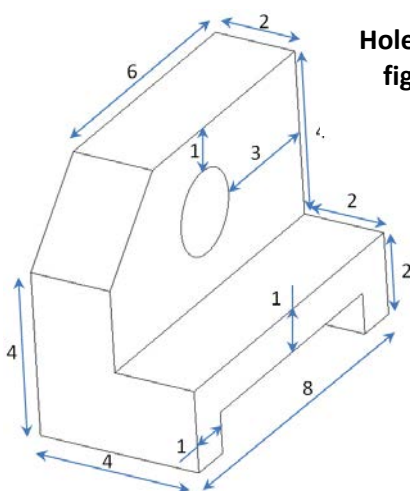

Figure 1

Hole radii in the two figures are 1 cm.

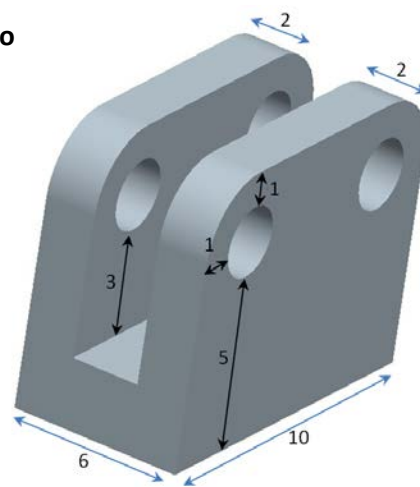

Figure 2

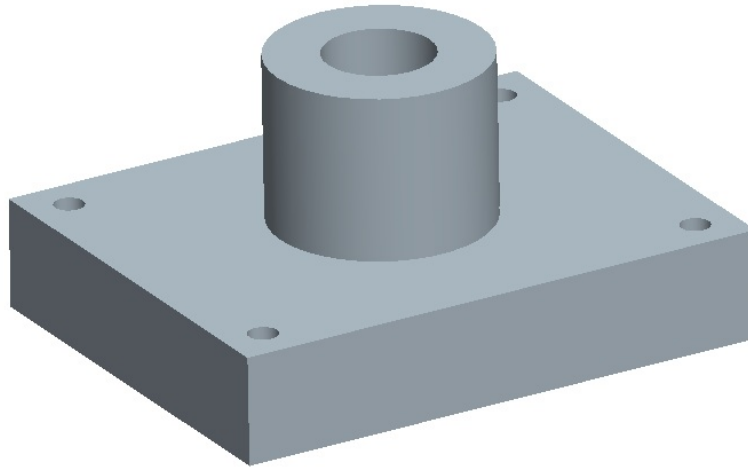

Figure 3: The precise dimensions of this component are given below:

- The base of the rectangular block is 8.0 cm × 10.0 cm
- A circular protrusion (diameter 4.0 cm and height 3.0 cm) is connected to the base such that the symmetry axis is normal to the top face plane and intersects the geometric centre of the base.
- There is a hole through the center of the protrusion that extends through the base to the bottom of the base. The diameter of the hole is 2.0 cm, and the depth of the hole is 5.0 cm.
- There are four through-holes, one at each corner of the rectangular top face: Diameter = 0.5# cm. Replace “#” with the last digit of your student number (**Note: these 4 holes go all the way through the base**)
- The center of each of the 4 through-holes is 0.7# cm from each edge. Replace “#” with the second last digit of your student number

III — Steps and Calculations:

1. For Part 1, calculate the efficiencies (η), as percentages, for each of the three pumps, keeping good track of the units and their conversions, and significant figures. Use the efficiencies to rank the pumps from most efficient to least efficient.
2. Generate Figure 15.25 following the instructions in Chapter 15 of the textbook.
3. Provide engineering drawings for each of the components given in Part 3. Refer to Chapter 12 of your textbook for guidance on how to produce engineering drawings. Include only the most essential dimensions and follow the dimensioning rules outlined in your textbook. Make sure to show all hidden lines and centre lines. The drawings must have an appropriate title block; a template is available on WebCT.
4. Calculate the total volume (cm^3) and the total surface area (cm^2) of the parts shown in Figures 1,2 & 3 and write it on the drawing by hand (*supporting calculations should be attached in an appendix*): write “Total surface area = # cm^2 ” and “Total volume = # cm^3 ” both results with 7 sig. figs. The ‘area’ command in IntellCAD may provide a useful check of your calculations.

IV — Report Requirements and Deliverables:

Using the guidelines presented in Laboratory 1, produce a formal laboratory report that summarizes your findings.

- In the “Results and Discussion” section of your report, among other things, you should:
 - report the results obtained for efficiency of the pumps calculated in Part 1;
 - rank the pumps from most to least efficient;
 - report the surface areas of the components shown in Figs. 1, 2 & 3;
 - report the volumes of the components shown in Figs. 1, 2 & 3;
 - try to avoid leaving any important data in the Appendix(ces) unmentioned and unsupported in the body of the discussion.
- In the appendix(ces) you must include:
 - all your calculations and conversion factors used in Parts 1 and 3;
 - a copy of Figure 15.25 produced in Part 2 using IntelliCAD. **Sign and date your printed reproduction;**
 - working drawings with proper title blocks of the three components in Part 3. On each drawing handwrite the volume and surface area of the component.
- Don’t forget that the written text of the report must be no longer than 1 page. Additional materials are to be included as appendix pages - sketches, figures and tables, etc. Note that the figures and tables must be properly labelled, titled and supported with text as described above.

Deliverables Summary	
<i>The lab assignment includes the following pages:</i>	
1.	Title page
2.	One-page report
3.	IntelliCAD Drawing of Figure 1 with a title block (total surface area and volume should be handwritten on the page <u>with 7 sig figs</u>)
4.	IntelliCAD Drawing of Figure 2 with a title block (total surface area and volume should be handwritten on the page <u>with 7 sig figs</u>)
5.	IntelliCAD Drawing of Figure 3 with a title block (total surface area and volume should be handwritten on the page <u>with 7 sig figs</u>)
6.	Your version of Figure 15.25 reproduced in IntelliCAD (Part 2): sign and date the printed reproduction.
7.	Typed or handwritten calculations
8.	IMPORTANT: upload an electronic version of your assignment to the P: drive folder*

*File name: “Lab Section_Student number.doc OR .docx” (e.g. “C3_100812345.doc” is for C3 Lab section)

V — Submission and Timing:

If your lab session is on Monday, Tuesday, Wednesday, or Thursday, then your report is to be submitted to the Teaching Assistant within the first 30 minutes of your next laboratory period (October 1 to October 4, 2012). **LATE SUBMISSIONS WILL NOT BE ACCEPTED.**

***If your lab session is on Friday:** Friday October 5, 2012 is University Day (there are no undergraduate classes). For those with labs normally held on Friday, this laboratory is due no later than 16:30 on Thursday October 4, 2012 in the ECOR 1010 slot of the orange cabinet located outside of 3135ME. **LATE SUBMISSIONS WILL NOT BE ACCEPTED.**

VI — Marking:

Laboratory submissions will be marked on a 10-point scale: 9-10 (excellent); 7-8 (good); 5-6 (marginal); less than 5 (fail). **Be sure that you are familiar with the University's policy on plagiarism and academic integrity. Your instructors are obligated to report all suspected violations to the Associate Dean's office for investigation (see also chapter 14 at www4.carleton.ca/calendars//ugrad/current_regulations).**

Length

1 ft = 0.3048 m

1 m = 3.2808 ft

1 in = 2.54 cm

1 cm = 0.3937 in

1 mi. = 5280 ft

1 km = 0.6214 mi.

Mass

1 lbm = 0.453592 kg

1 kg = 2.20462 lbm

1 slug = 14.594 kg

1 slug = 32.174 lbm

1 ton = 2000 lbm

1 tonne = 1000 kg

Pressure

1 psi = 6.894757 kPa

1 Pa = 145.04×10^{-6} psi

1 bar = 100 kPa

1 atm = 101.325 kPa

1 atm = 14.696 psi

1 in. Hg = 0.4912 psi

1 mm Hg = 0.1333 kPa

1 in. Hg = 3.387 kPa

Energy

1 Btu = 1.055056 kJ

1 kJ = 0.947817 Btu

1 lbf.ft = 1.35582 J

1 J = 0.73756 lbf.ft

1 cal = 4.1840 J

1 IT cal = 4.1868 J

1 Btu = 778.169 lbf.ft

Volume

1 ft³ = 0.028317 m³

1 m³ = 35.315 ft³

1 in³ = 16.387 cm³

1 cm³ = 0.061024 in³

1 US gal = 0.0037854 m³ = 231 in³

1 Imp gal = 1.2009 US gal

1 lt. = 0.001 m³

1 lt. = 0.0353 ft³

Density

1 lbm/ft³ = 16.018 kg/m³

1 kg/m³ = 0.062428 lbm/ft³

Specific Volume

1 ft³/lbm = 0.062428 m³/kg

1 m³/kg = 16.018 ft³/lbm

Force

1 lbf = 4.448222 N

1 N = 0.224809 lbf

1 dyne = 1×10^{-5} N

Specific Energy

1 Btu/lbm = 2.326 kJ/kg

1 kJ/kg = 0.42992 Btu/lbm

1 Btu/lbmol = 2.326 kg/kmol

1 kJ/kmol = 0.42992 Btu/lbmol

Energy Transfer Rate

1 Btu/s = 1.055056 kW

1 kW = 0.947817 Btu/s

1 HP = 550 lbf.ft/s

1 HP = 2545 Btu/hr

1 HP = 0.7457 kW