

NAME: Solution LAB: _____ STUDENT NO. _____

APSC 150 – 2010/11 Term I
CASE 2: Chemical Reaction Car

6:30 – 8:30 pm, Monday, October 25, 2010

Quiz Instructions

THIS IS A CLOSED-BOOK, CLOSED-NOTES QUIZ

Internet use is not permitted during the quiz

Please be sure to clearly write your name, **student number** and your laboratory section on your scantron card. Please do this NOW!

Your scantron card is the only thing to be marked, so be sure you fill your answers accurately

Number of questions = 10 ; Total marks = 115 ; (100 is the full mark + 15 bonus)

Good luck

(10 marks)

1. In the following reaction:

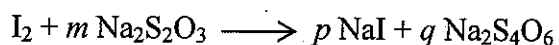

m is equal to:

- A. 0.5
- B. 1
- C. 2
- D. 3
- E. 4

$$I: \boxed{2 = p}$$

$$Na: 2m = p + 2q$$

$$S: 2m = 4q$$

$$O: 3m = 6q$$

$$\therefore 2m = p + m$$

$$\boxed{m = p = 2}$$

$$m = 2q \Rightarrow \boxed{q = 1}$$

$$\boxed{m = 2} \checkmark$$

(5 marks)

2. For the chemical reaction: $A \longrightarrow 4B + 2C$

the reaction rate, r , can be expressed as:

A. $\frac{1}{4} \frac{dB}{dt}$

B. $6 \frac{dA}{dt}$

C. $\frac{1}{6} \frac{dA}{dt}$

D. $4 \frac{dB}{dt}$

E. $2 \frac{dC}{dt}$

$$r = -\frac{dA}{dt} = \frac{1}{4} \frac{dB}{dt} = \frac{1}{2} \frac{dC}{dt}$$

(6 marks)

3. Hydrogen peroxide decomposes at 303 K according to the following reaction:

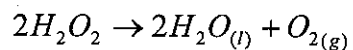

If 75 grams of hydrogen peroxide is used initially, **the mass of oxygen and water produced would be:**

Hint:

The molecular weights (M_w) of H_2O_2 , H_2O , and O_2 are: 34, 18, and 32 [g/mole], respectively.

- A. 50 [grams]
- B. 75 [grams]
- C. 125 [grams]
- D. 68 [grams]
- E. 100 [grams]

Reactants \longrightarrow Products

$$m_{in} = m_{out}$$

(10 marks)

4. If the reaction described in question 2 decomposes according to the following reaction:

$$[H_2O_2] = [H_2O_2]_0 e^{-kt}$$

and half of the hydrogen peroxide initially decomposes in 4 minutes. The value of k would be:

- A. 0.13 [minute]
- B. 0.17 [minute]
- C. 5.77 [1/second]
- D. 5.77 [1/minute]
- E. 0.17 [1/minute]

as in version (1)

$$k = -\frac{\ln 0.5}{t_{1/2}}$$

$$= -\frac{\ln 0.5}{4 \text{ min}}$$

$$k = 0.17 \left[\frac{1}{\text{min}} \right]$$

(11 marks)

5. An air tank drains into the atmosphere under the conditions given in the Figure below.

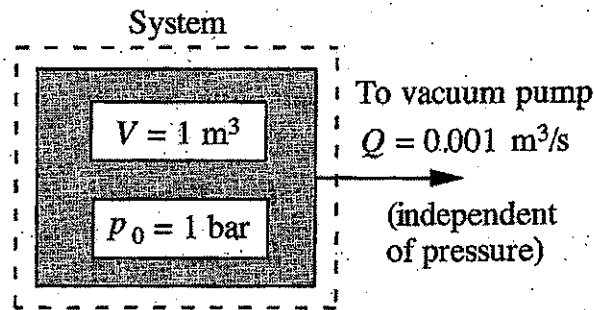

Which of the following is incorrect?

- A. The mass balance for this system is given by: $\frac{dm}{dt} = -\dot{m}_{out}$
- B. The mass of the gas in the control volume is represented by: $m = \frac{M_w PV}{RT}$
- C. The rate at which mass is lost from the tank is given by: $\dot{m}_{out} = Q\rho$
- D. The pressure in the tank diminishes according to: $P(t) = P_0 e^{-Q_0 t/V}$
- E. The density in the tank diminishes according to: $\ln \frac{\rho}{\rho_0} = \frac{V}{Q} t$

* See version(1) for more details about the solution of the quiz

(17 marks)

6. The pipe flow, shown in the Figure below, fills a cylindrical tank as shown. The diameters of the tank and the pipe are D and d , respectively. If at time $t = 0$, the water depth in the tank is 40 cm, the time required to fill the remainder of the tank is:

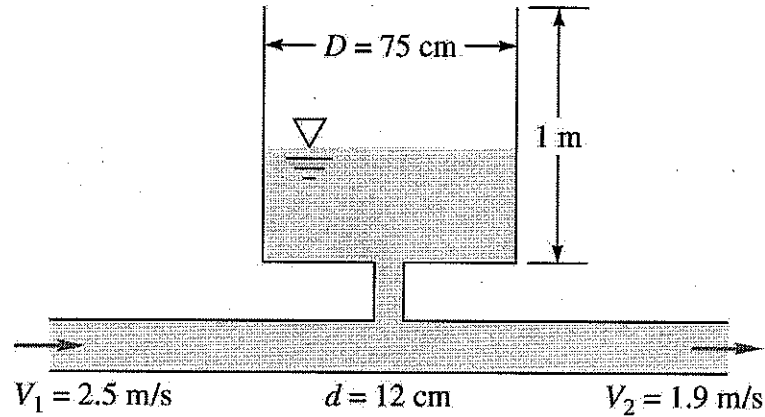

Hint:

The conservation of mass equation is: $\frac{dm}{dt} = \dot{m}_m - \dot{m}_{out}$

- A. 6.25 [min]
- B. ∞
- C. 46 [s]
- D. 39 [s]
- E. 156 [s]

See the detailed solution in version 1

$$0.6 = \left(\frac{0.12}{0.75} \right)^2 (2.5 - 1.9) t$$

$$t = 39 \text{ [s]}$$

(14 marks)

7. For the tank given below, if the initial $h = 125$ cm (at $t = 0$); the initial exit velocity of the liquid (u_2) would be:

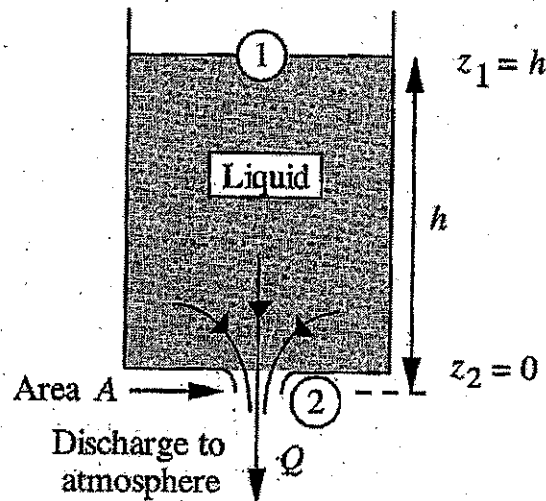

Hints:

$$g = 9.81 \text{ m/s}^2 ; \rho = 1000 \text{ kg/m}^3$$

Bernoulli's equation between points (1) and (2) is: $\frac{P_1}{\rho} + \frac{u_1^2}{2} + gz_1 = \frac{P_2}{\rho} + \frac{u_2^2}{2} + gz_2$

- A. 3.50 [m/s]
- B. 49.52 [cm/s]
- C. 4.95 [m/s]
- D. 24.53 [m/s]
- E. 49.52 [m/s]

See version 1 of the quiz

$$u_2(t=0) = \sqrt{2(9.81)(1.25)}$$
$$= 4.95 \left[\frac{\text{m}}{\text{s}} \right]$$

(12 marks)

8. A police jeep is moving at 80 km/h and is chasing a stolen jeep moving at 160 km/h. If the police officer fires a bullet with a muzzle velocity of 180 m/s, the velocity with which the bullet strikes the stolen jeep would be:

- A. 80 [m/s]
- B. 100 [m/s]
- C. 158 [m/s]
- D. 180 [m/s]
- E. 100 [km/h]

Same as in version 1

$$V_{\text{strike}} = (80 - 160) \times \frac{10^3}{3600} + 180$$
$$= 158 \left[\frac{\text{m}}{\text{s}} \right]$$

(14 marks)

9. The dredger, shown in the Figure below, is loading sand that has a density = 2600 kg/m^3 onto a barge. If the sand leaves the dredger pipe at 2 m/s with a volumetric flow rate = $0.005 \text{ m}^3/\text{s}$, the tension on the mooring line caused by this loading process would be:

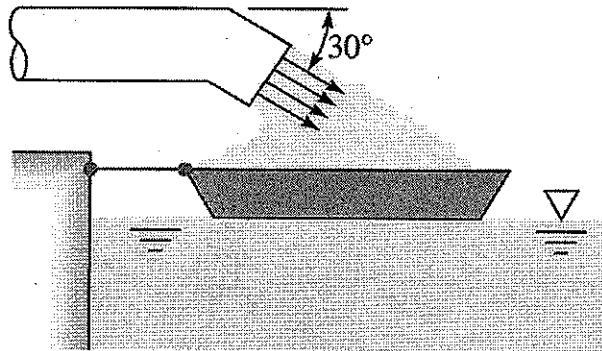

Hints:

$$g = 9.81 \text{ m/s}^2$$

The force/momentum conservation equation is: $\frac{d(mu)}{dt} = \sum F = (\dot{m}u)_{out} - (\dot{m}u)_{in}$

- A. 4 [kg m/s²]
- B. 13 [kg m/s²]
- C. 22.52 [kg m/s²]
- D. 25.69 [kg m/s²]
- E. 26 [kg m/s²]

See version 1

$$T = - 2600 \frac{\text{kg}}{\text{m}^3} \times 0.005 \frac{\text{m}^3}{\text{s}} \times 2 \frac{\text{m}}{\text{s}} \times \cos(\pi/6)$$
$$= - 22.52 \text{ [N]} \text{ to the left (-x)}$$

(16 marks)

10. As shown in the Figure below, the vane turns the water jet completely around. The diameter of the vane $D_0 = 10$ cm, and the density of water $\rho = 1000$ kg/m³.

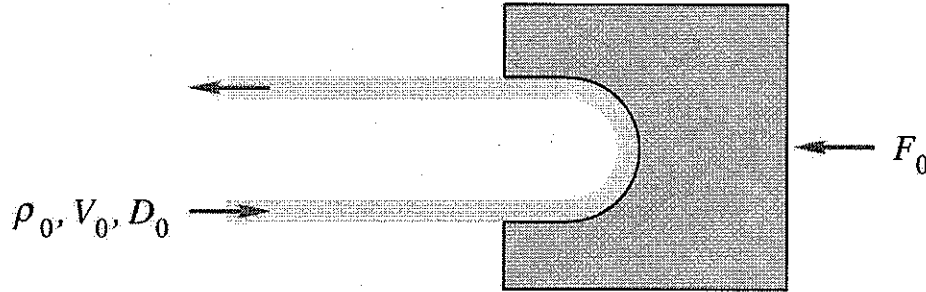

If the maximum possible support force, $F_0 = 5$ Newton, the maximum jet velocity V_0 should be:

Hint:

The force/momentum conservation equation is: $\frac{d(mu)}{dt} = \sum F = (\dot{m}u)_{out} - (\dot{m}u)_{in}$

A. 0.00 [m/s]

B. 0.06 [m/s]

C. 0.40 [m/s]

D. 56 [cm/s]

E. 32 [cm/s]

$$\begin{aligned} & \downarrow \quad \downarrow \\ & 0 \quad F_0 \\ \dot{m}_{out} &= \dot{m}_{in} \\ A_{out} &= A_{in} \Rightarrow V_{out} = V_{in} = V_0 \end{aligned}$$

$$\begin{aligned} \therefore F_0 &= \dot{m} (V_{out} - V_{in}) = \dot{m} (2V_0) \\ &= 2(\rho A_0 V_0) V_0 = 2\rho A_0 V_0^2 = 2\rho \left(\frac{D_0}{2}\right)^2 \pi V_0^2 \end{aligned}$$

$$\Rightarrow V_0 = \sqrt{\frac{F_0}{\rho \left(\frac{\pi}{2}\right) D_0^2}} = \sqrt{\frac{5}{1000 \left(\frac{\pi}{2}\right) (0.1)^2}} = 56 \left[\frac{\text{cm}}{\text{s}}\right]$$