

GNG1105E – Midterm Exam

October 24 2019

Student Number: _____

****NOTE: This exam is CLOSED BOOK and must be completed individually.**

- Calculators are permitted.
- You have 1 hour and 15 minutes to complete this exam.
- There are **three** questions. Marks for each question are as indicated.
- You must submit your question sheet with your answer booklet.
- This exam is double-sided.

1. A welded connection is in equilibrium under the action of the four forces shown. Knowing that $F_A = 8 \text{ kN}$ and $F_B = 16 \text{ kN}$, determine the magnitudes of the other two forces.

[5 marks]

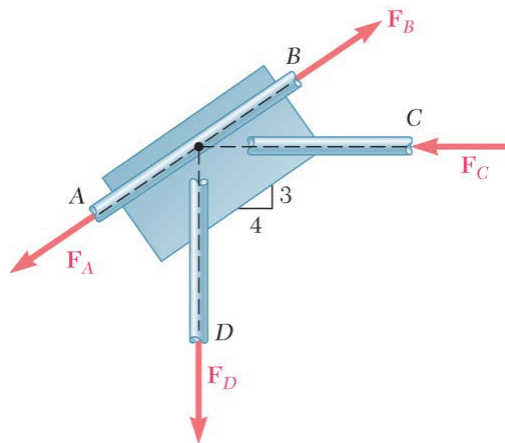

2. To test the strength of a 625 x 500 mm suitcase, forces are applied as shown. If $P = 88 \text{ N}$, a) determine the resultant of the applied forces, and b) locate the two points where the line of action of the resultant intersects the edge of the suitcase. **[15 marks]**

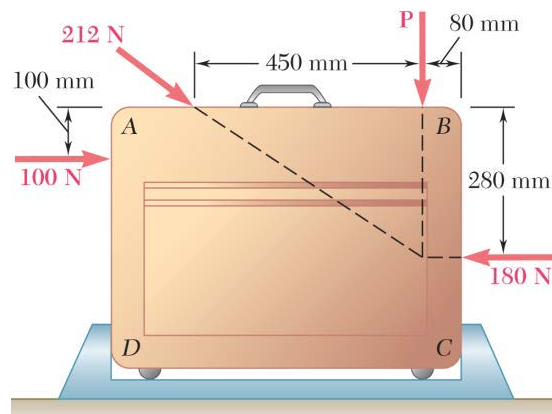

3. The rigid L-shaped member ABC is supported by a ball-and-socket joint at A and by three cables. If a 1.8 kN load is applied at F, determine the tension in each cable and the components of the reaction at A. **[20 marks]**

