

Data Communication and Computer Networks

1. Computer Networks & The Internet

Dr. Aiman Hanna

Department of Computer Science & Software Engineering
Concordia University, Montreal, Canada

These slides have mainly been extracted, modified and updated from original slides of :
Computer Networking: A Top Down Approach, 6th edition Jim Kurose, Keith Ross
Addison-Wesley, 2013

Additional materials have been extracted, modified and updated from:
Understanding Communications and Networking, 3e by William A. Shay 2005

History of Communications

For 1000s of years through auditory & visual senses

- Visual senses:
 - » Face to face
 - » Reading messages/letters/symbols/sketches
 - » Seeing visual signals (smoke, fire, ..etc).
 - » ...
- Auditory senses:
 - » Direct listening
 - » Listening through messengers
 - » ...

History of Communications

- ❖ Drastic change in **1837**
 - The invention of the **telegraph** by Samuel Morse
 - Characters of a message were translated into long and short electrical impulses
 - These impulses were then transmitted over a copper wire
 - The association between the characters and the impulses was called **Morse Code**

- ❖ **1876: The Magical invention of **Telephony** by Alexander Graham Bell**
 - Bell showed that voice can be converted directly into electrical energy
 - This energy can then be transmitted over a wire using continuously varying voltages

History of Communications

❖ Switchboards

- Early telephones required a pair of wires that connects telephones at both ends
- That changed with the invention of the switchboard, a switching device that connected lines between two phones
- Establishing connections was activated through an operator at the switchboard



OLD SWITCHBOARD OF BELL EXCHANGE SERVING CHINATOWN, SAN FRANCISCO CALIFORNIA



History of Communications

❖ 1945: ENIAC

- Electronic Numerical Integrator And Calculator
- The 1st electronic computer
- Designed for computing ballistics for World War II
- Although did not play a direct role in communication, it did show that calculations and decision making could be done electronically

❖ 1947: The Transistor

- Allowed smaller and affordable computers to be built
- Computers applications developed during the 1960s made routing and processing telephone calls economically possible
- The increased utilization of computers by businesses resulted in a growing need to transfer information between these computers as well

History of Communications

❖ **Electronic Communications -**

The massive need in relatively short time

- The 1st form of communication between systems were done through magnetic tapes
- Information were copied from on system into a tape; which is transferred to another system, possibly a remote one
- The development of the Personal Computer (PC) in the 1980s was a milestone in electronic communication
- The infusion of millions of PCs into, virtually, everywhere created a further massive need to make information easily accessible
- At this point it was clear that the need for electronic communication was no longer a luxury, rather a necessity and a must

❖ **1990s: The **World Wide Web (WWW)** & The **Internet****

- *WWW is application* that enabled information from around the world to become easily accessible from one's desk.
- The Internet is an electronic network of computers that includes nearly every university, government, and research facility in the world, as well as many commercial sites
- The Internet started with four interconnected computers in 1969 and was known as ARPAnet

What's the Internet: "nuts and bolts" view



- ❖ millions of connected computing devices:
 - *hosts* = *end systems*
 - running *network apps*

- ❖ *communication links*

- fiber, copper, radio, satellite
- transmission rate: *bandwidth*

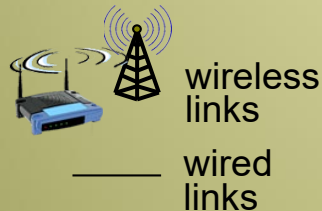

- ❖ *Packet switches*: forward packets (chunks of data)
 - *routers* and *switches*

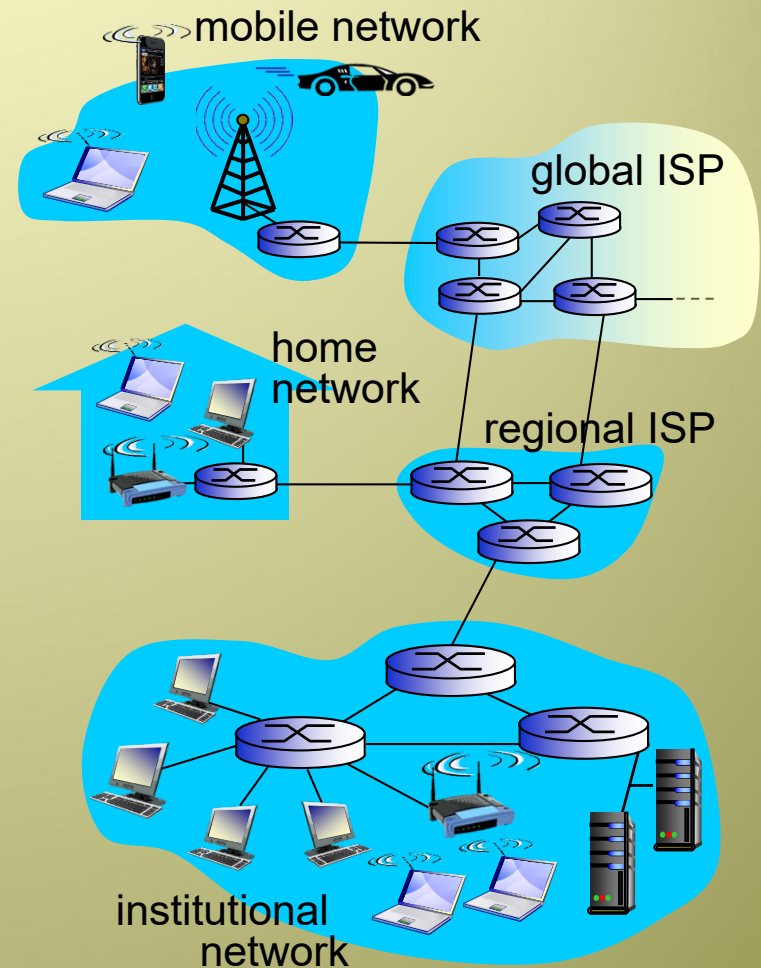

“Computer Networks”; an Outdated Term?

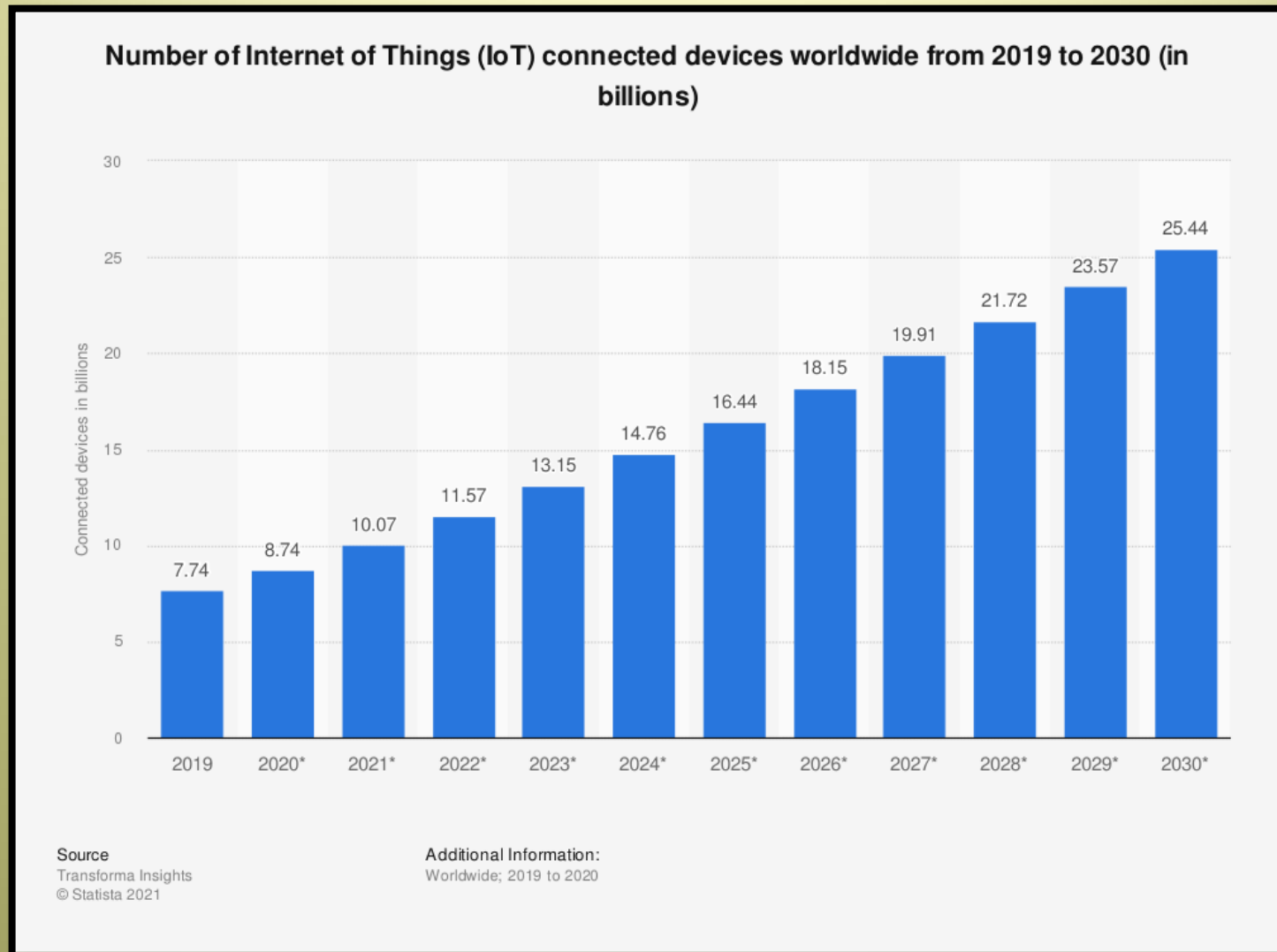

What's the Internet: "nuts and bolts" view

- ❖ **Internet: "network of networks"**
 - Interconnected ISPs
- ❖ **protocols** control sending, receiving of msgs
 - e.g., TCP, IP, HTTP, Skype, 802.11
- ❖ **Internet standards**
 - RFC: Request for comments
 - IETF: Internet Engineering Task Force

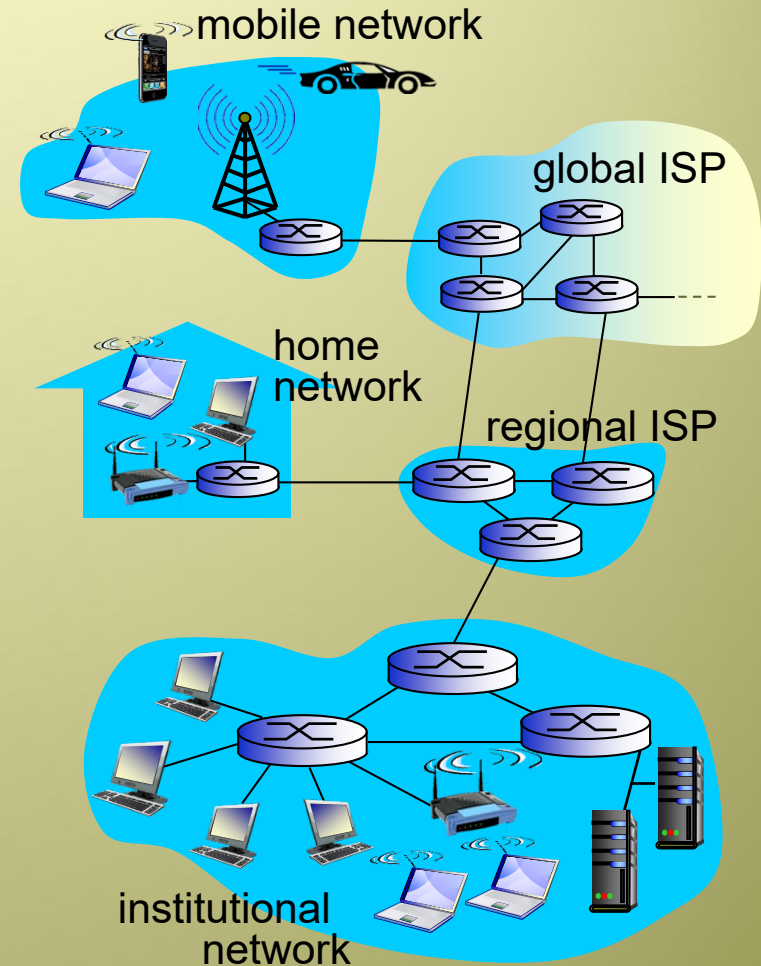

“Fun” Internet appliances



Internet refrigerator



Web-enabled toaster:
Designs, weather, news, etc.



Tweet-a-watt:
monitor energy use



PoIP: IP picture frame
<http://www.ceiva.com/>



Slingbox:
Control & watch cable
TV remotely



Internet phones

What's the Internet: a service view

- ❖ *Infrastructure that provides services to applications:*
 - Web, VoIP, email, games, e-commerce, social nets, ...
 - Distributed applications
- ❖ *provides programming interface to apps*
 - hooks that allow sending and receiving app programs to “connect” to Internet
 - Provides various service options, analogous to postal service

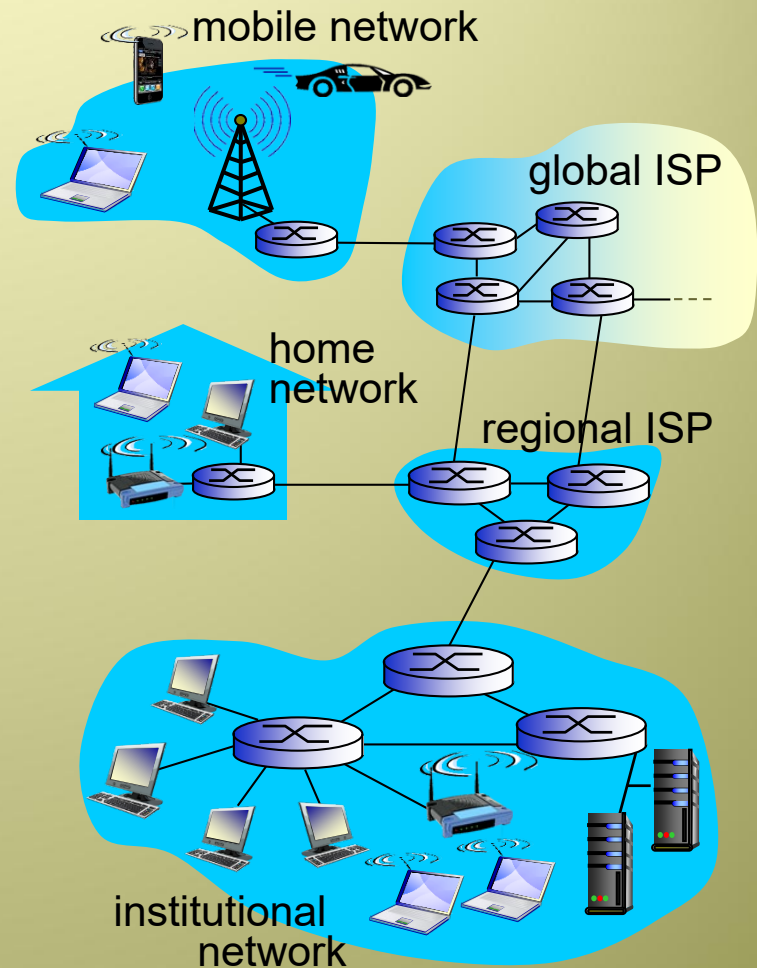

What's a protocol?

human protocols:

- ❖ “what's the time?”
 - ❖ “I have a question”
 - ❖ introductions
- ... specific msgs sent
- ... specific actions taken when msgs received, or other events

network protocols:

- ❖ machines rather than humans
- ❖ all communication activity in Internet governed by protocols

protocols define format, order of msgs sent and received among network entities, and actions taken on msg transmission, receipt

What's a protocol?

a human protocol and a computer network protocol:

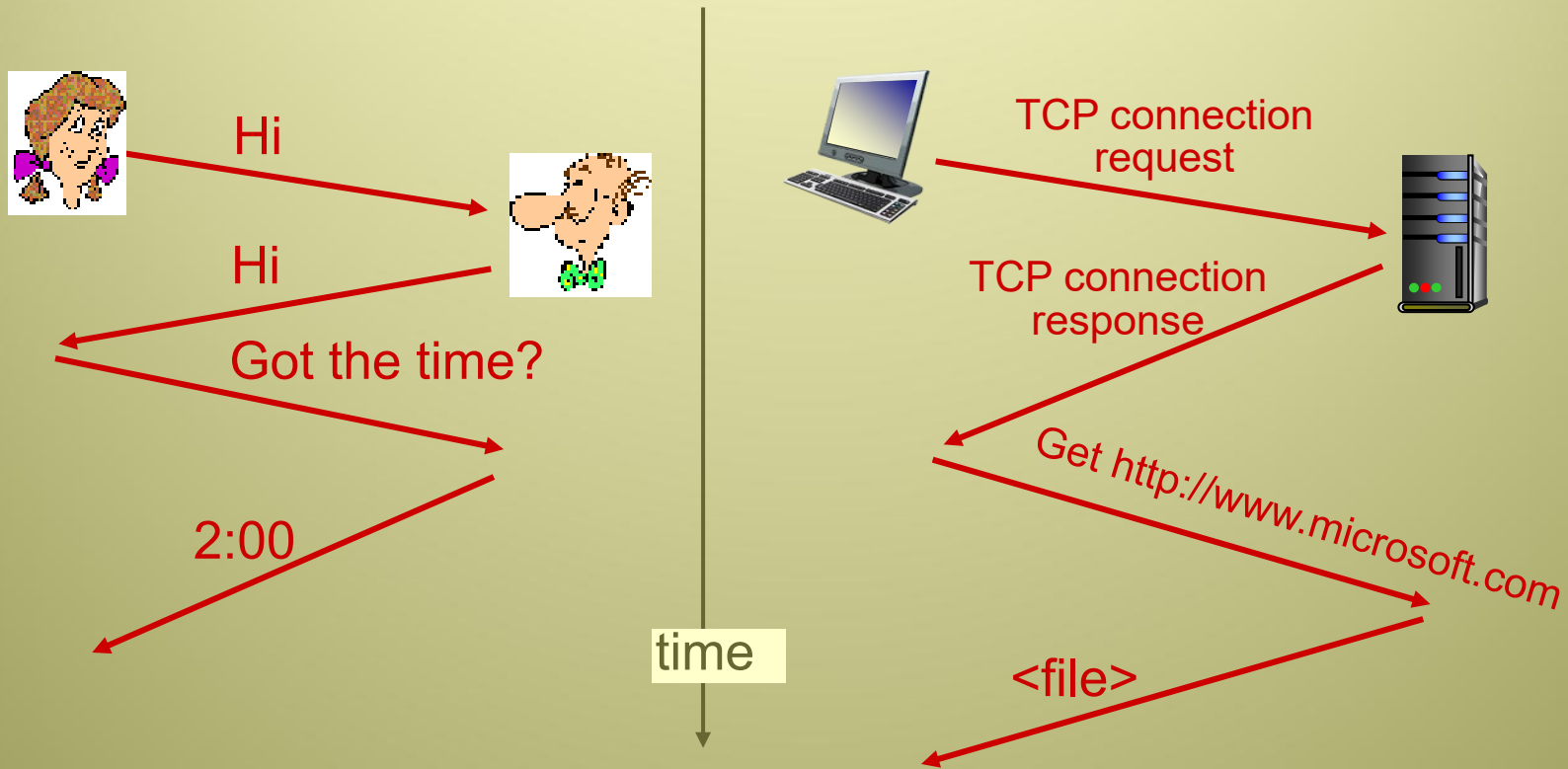

Q: other human protocols?

A closer look at network structure:

❖ *network edge:*

- Hosts/end systems: clients and servers
- servers often in data centers

❖ *access networks, physical media:* wired, wireless communication links

❖ *network core:*

- interconnected routers
- network of networks

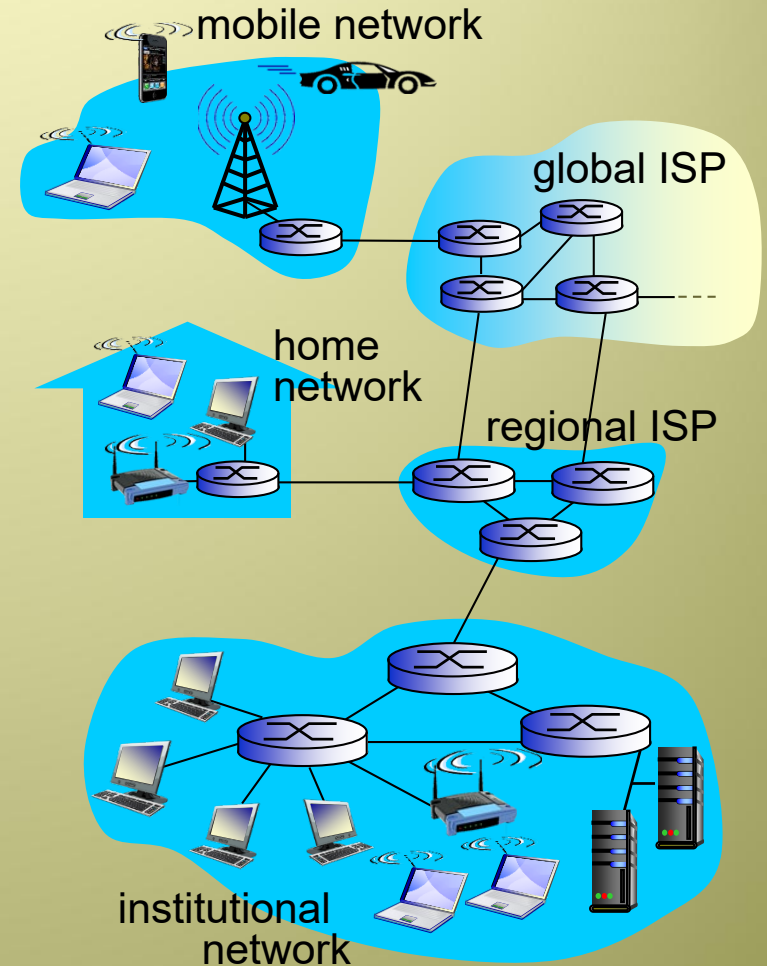

Access networks and physical media

Q: How to connect end systems to edge router?

- ❖ residential access nets
- ❖ institutional access networks (school, company)
- ❖ mobile access networks

keep in mind:

- ❖ bandwidth (bits per second) of access network?
- ❖ shared or dedicated?

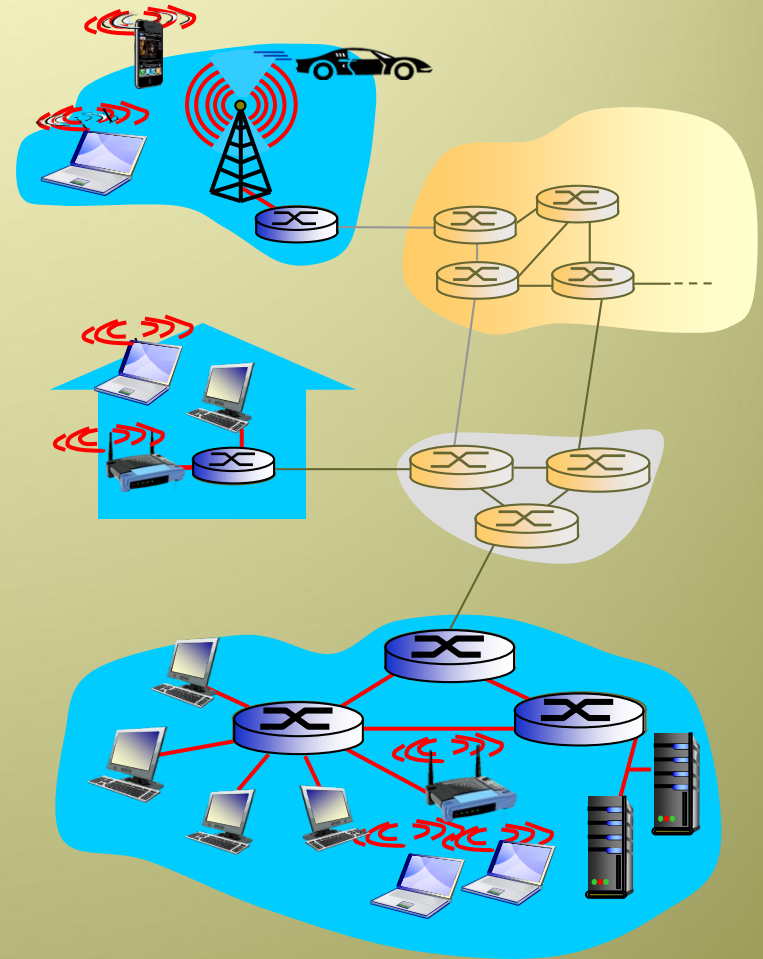

Modems and early ISP connections

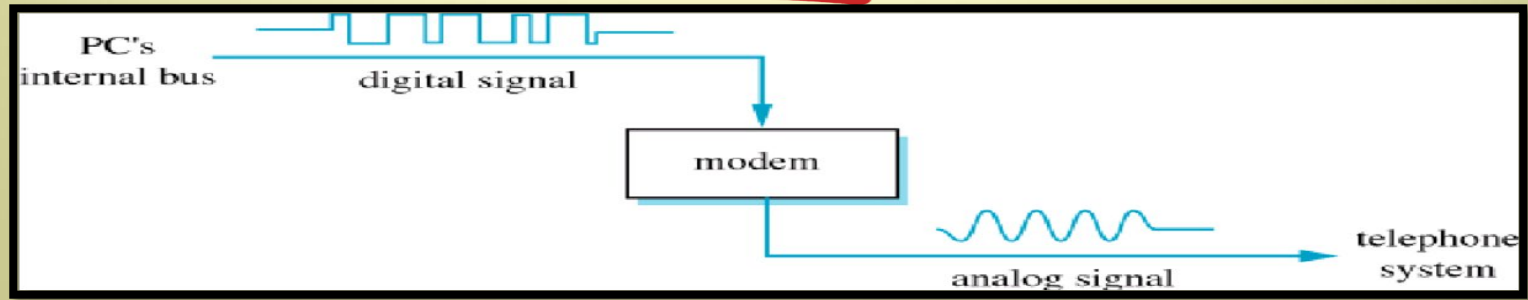

- ❖ During the 1980s, 2400 & 9600 bps modems became common
- ❖ In early 1990s, modems with a rate of 28.8 and 33.6 kbps became common
- ❖ Not longer after that, 56 kbps modems were achievable when connecting directly with ISPs

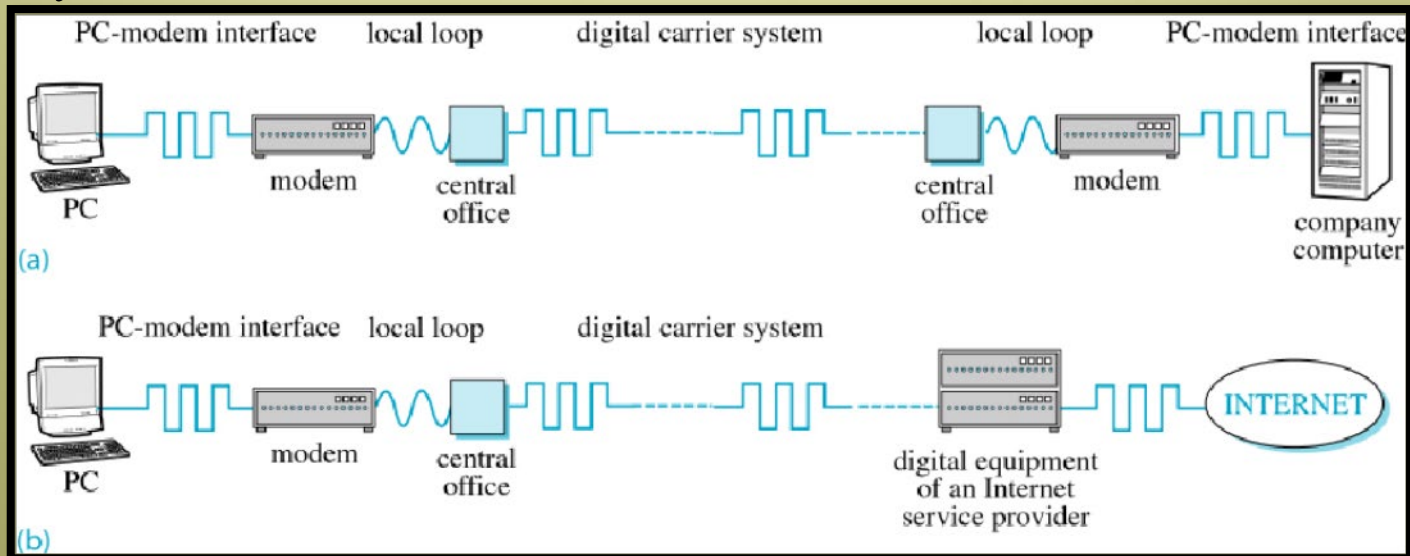

Access net: digital subscriber line (DSL)



Local Loop - POTS (Plain Old Telephone Service) Configuration

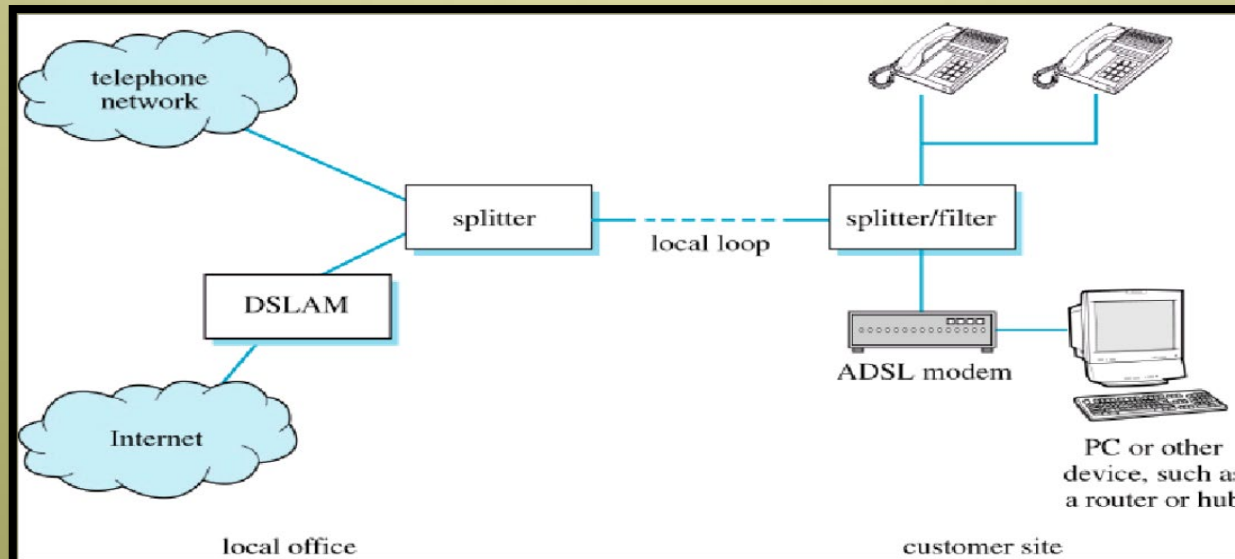

Asymmetric DSL (ADSL) Connection

Access net: digital subscriber line (DSL)

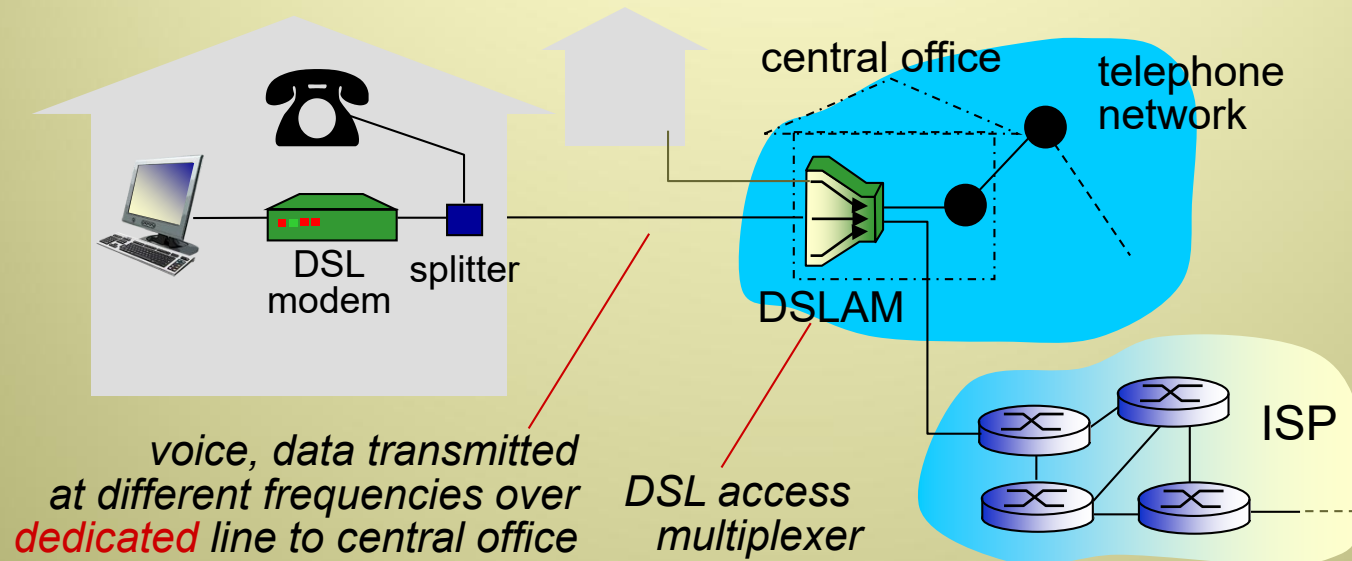

- ❖ use *existing* telephone line to central office DSLAM
 - data over DSL phone line goes to Internet
 - voice over DSL phone line goes to telephone net
- ❖ < 2.5 Mbps upstream transmission rate (typically < 1 Mbps)
- ❖ < 24 Mbps downstream transmission rate (typically < 10 Mbps)

Access net: cable network

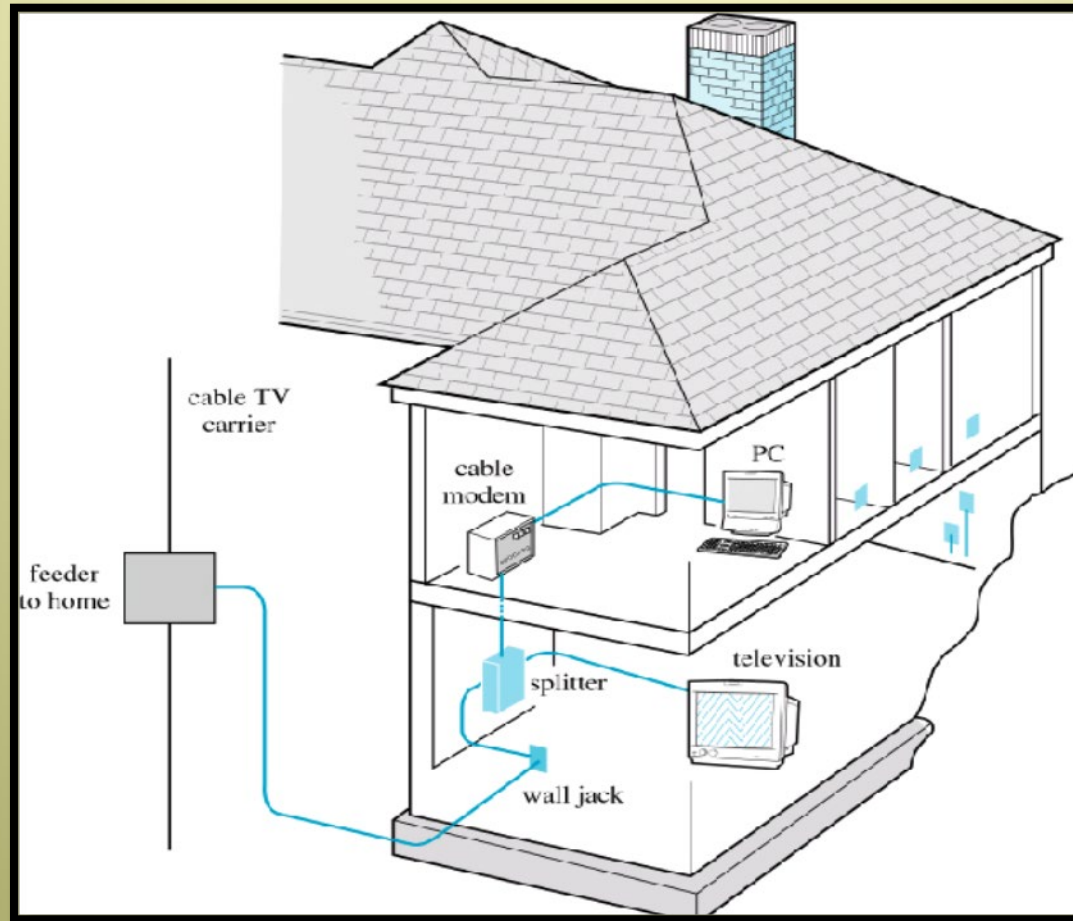

Cable Internet Access

Access net: cable network

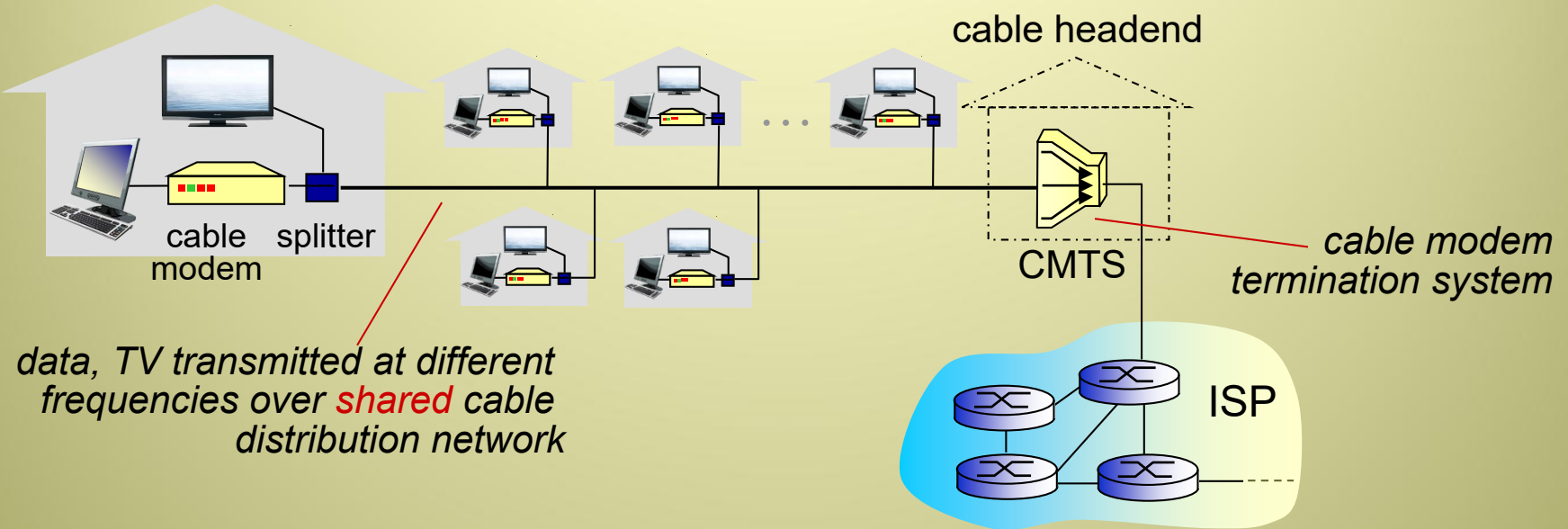

❖ HFC: hybrid fiber coax

- asymmetric: up to 30Mbps downstream transmission rate, 2 Mbps upstream transmission rate
- ❖ **network** of cable, fiber attaches homes to ISP router
 - homes *share access network* to cable headend
 - unlike DSL, which has dedicated access to central office

Access net: cable network

- ❖ Example: speed testing over a cable Internet access – Mid 2013

The screenshot shows a web browser window with the URL `testvitesse.videotron.ca/index-en.htm`. The page is titled "SPEED TEST" and contains the following information:

- Measure your Internet access speed.**
- To ensure the validity of the speed test, you must:**
 1. plug the computer directly into the cable modem;
 2. verify that the computer is not running other tasks;
 3. check that only the speed test uses the Internet connection.
- Restart test** button
- Download speed:** 38.22 Mbps
- Upload speed:** 1.55 Mbps
- Your IP:** 173.178.215.22
- PING:** 9ms
- Powered by **net metrics** and **OOKLA**

At the bottom, there is a section titled "Need more speed?" with the text "Choose the Internet access that best suits your needs." and a link to "Visit our Internet Services".

Access net: cable network

- ❖ Example: speed testing over a cable Internet access – September, 2020

The screenshot shows the Videotron website's speed test interface. The page title is "Speed test" and the subtitle is "Measure your Internet access speed." The test results are displayed in a 2x2 grid:

Metric	Value
PING	18 ms
DOWNLOAD	45.0 Mbps
JITTER	1 ms
UPLOAD	11.0 Mbps

The download and upload results are partially obscured by yellow redaction bars. A large yellow circle with the word "AGAIN" inside indicates a failed test. The website footer includes the Videotron logo and the URL "testvitesse.videotron.ca".

Access net: digital subscriber line (DSL)

VDSL – Very High Data Rate DSL

- ❖ The local loop causes many DSL problems
- ❖ Signal degrades over long distance, so DSL is not available if the house is more than 3.5 miles from the local office
- ❖ New improved local loop using fiber/copper hybrid is used, which improves quality, reduces the copper length and makes VDSL possible

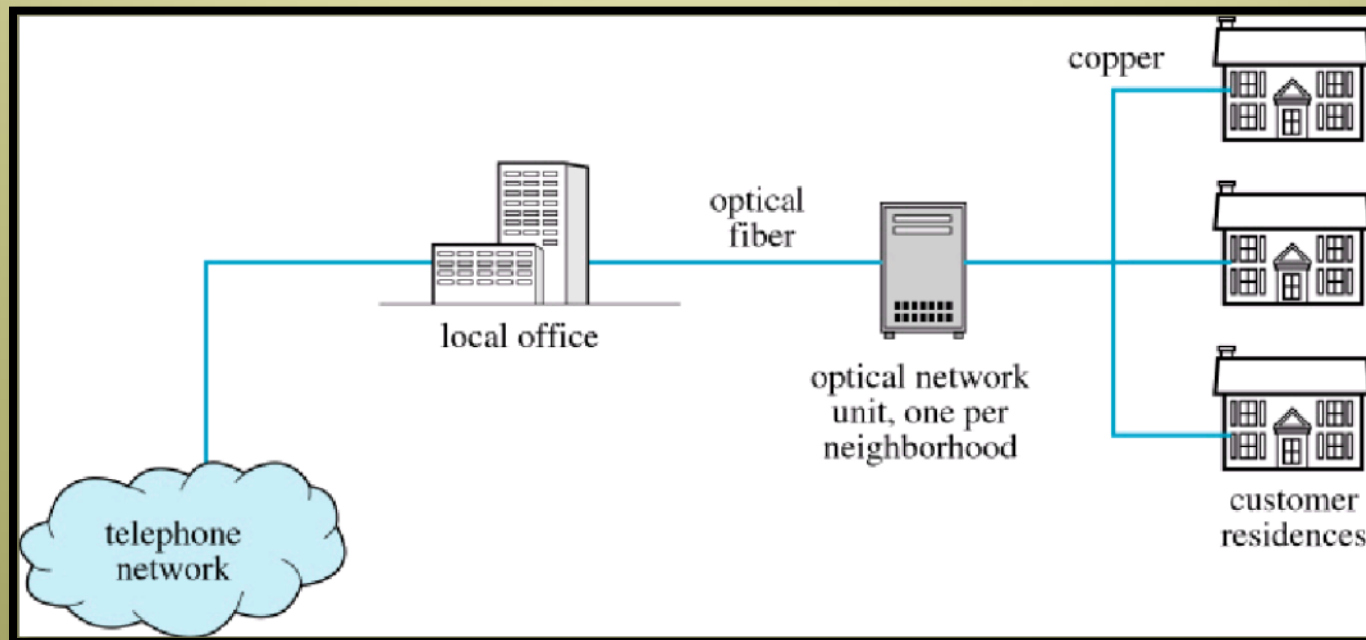

Local Loop: Fiber/Copper Hybrid

Access net: Ethernet & WiFi

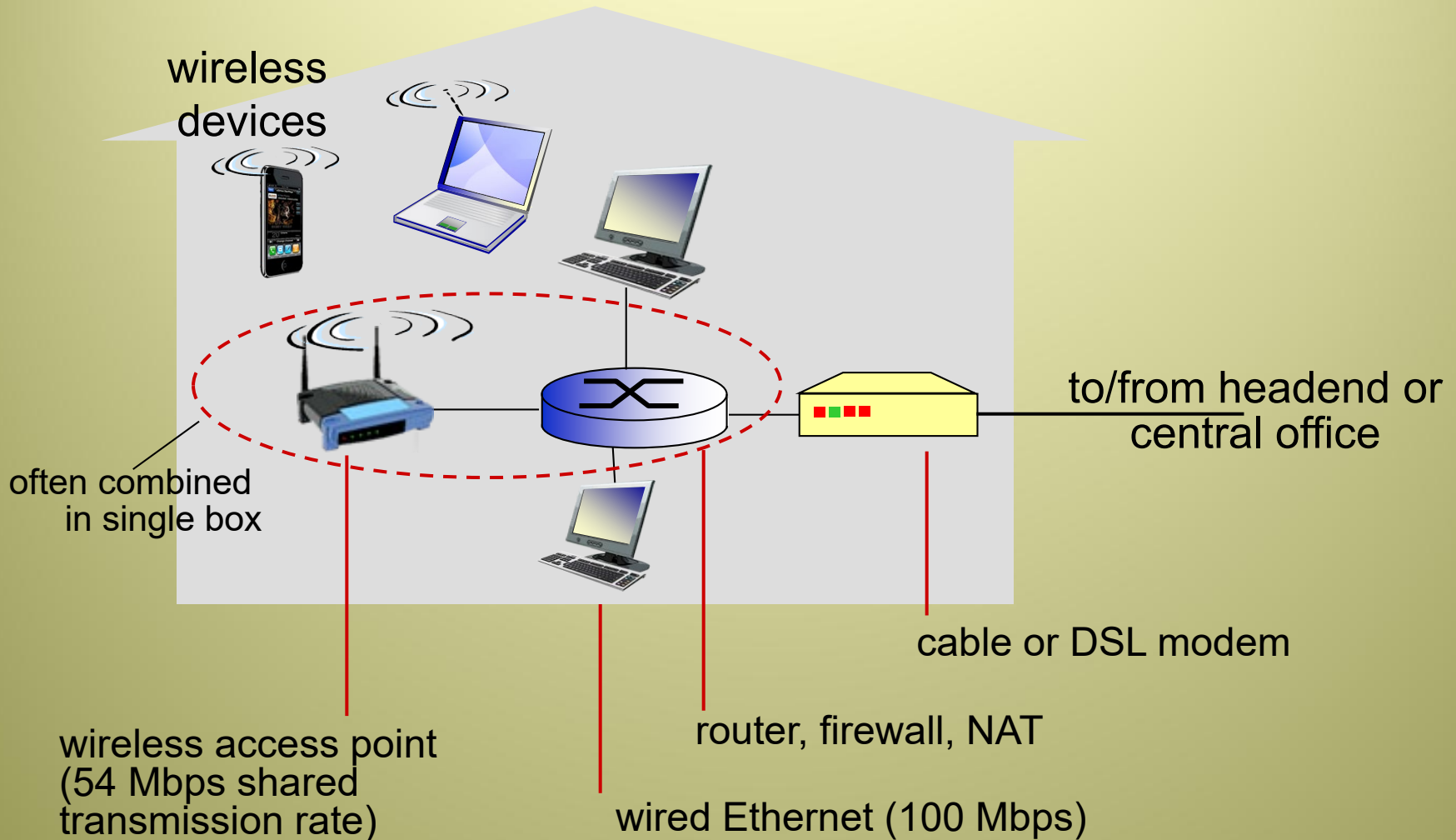

Enterprise access networks (Ethernet)

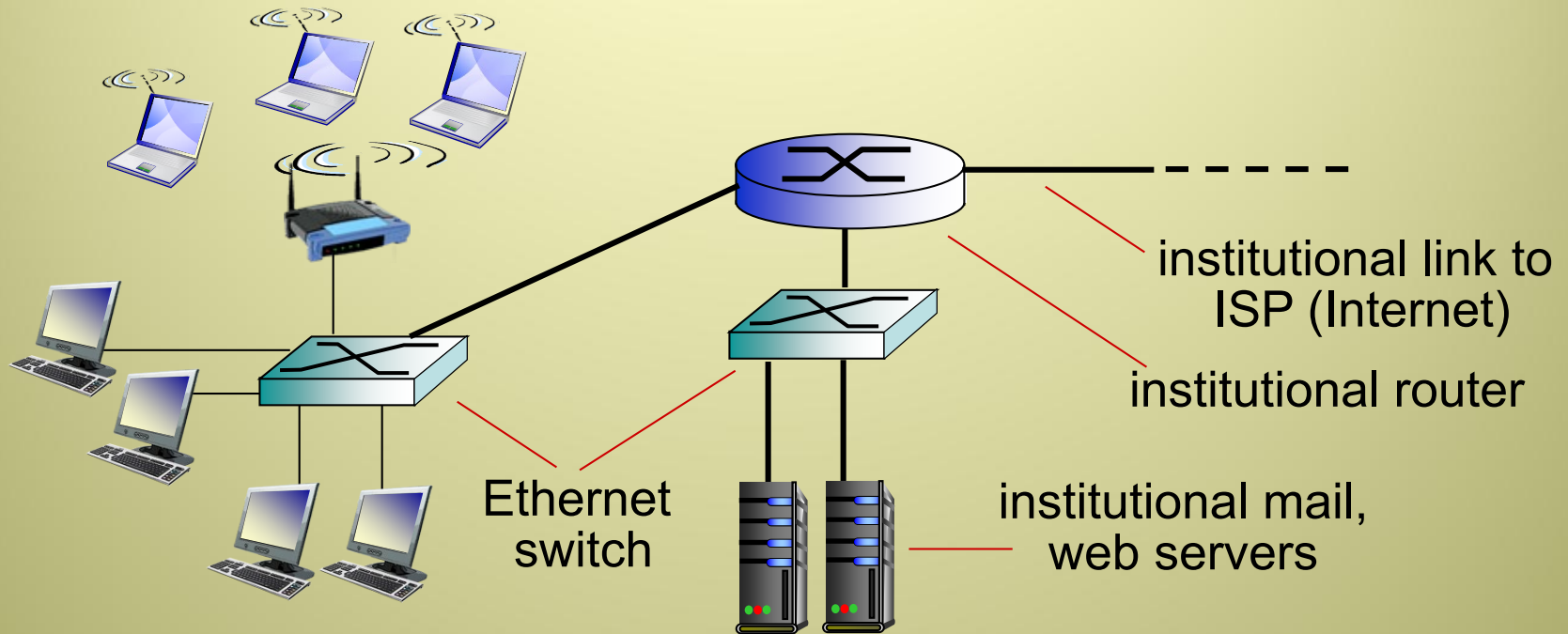

- ❖ typically used in companies, universities, etc
- ❖ 10 Mbps, 100Mbps, 1Gbps, 10Gbps transmission rates
- ❖ today, end systems typically connect into Ethernet switch

Wireless access networks: 3G and LTE

- ❖ shared *wireless* access network connects end system to router
 - via base station aka “access point”

wireless LANs:

- within building (100 ft)
- 802.11b/g (WiFi): 54 Mbps transmission rate

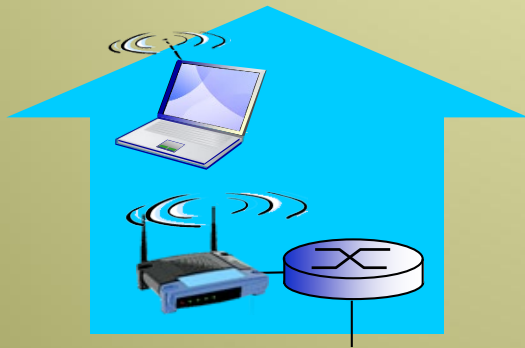

to Internet

wide-area wireless access

- provided by telco (cellular) operator, 10's km
- between 1 and 10 Mbps
- 3G, 4G: LTE



to Internet

Physical media

- ❖ **bit:** propagates between transmitter/receiver pairs
- ❖ **physical link:** what lies between transmitter & receiver
- ❖ **guided media:**
 - signals propagate in solid media: copper, fiber, coax
- ❖ **unguided media:**
 - signals propagate *freely*, e.g., radio

twisted pair (TP)

- ❖ two insulated copper wires



- Category 5: 100 Mbps, 1 Gbps Ethernet
- Category 6: 10Gbps



Physical media: twisted pairs

- ❖ Copper is usually used due to its less resistance to electricity, as well as high resistance to corrosion
- ❖ Twisted wires use balanced signals; 180° out of phase
- ❖ More twists reduce ***crosstalk***, the electromagnetic interference between adjacent pairs
 - Although copper has less resistance to electricity, signal will eventually die (***attenuate***)
 - ***Repeaters*** are used to solve this problem
 - Two types of twisted pair wires exist: Unshielded (UTP) & Shielded (STP); they have different cost & quality

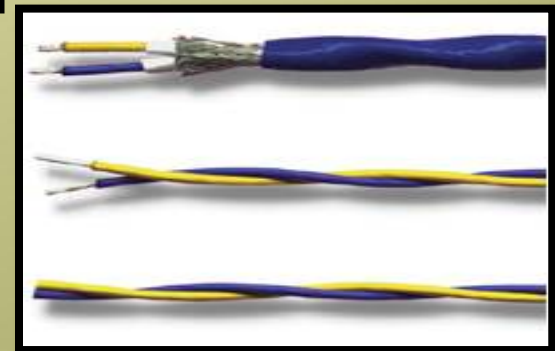

Physical media: coax, fiber

coaxial cable:

- ❖ two concentric copper conductors
- ❖ Bidirectional
- ❖ 10s of Mbps
- ❖ broadband:
 - multiple channels on cable
 - HFC

fiber optic cable:

- ❖ glass fiber carrying light pulses, each pulse a bit
- ❖ high-speed operation:
 - high-speed point-to-point transmission (e.g., 10' s-100' s Gpbs transmission rate)
- ❖ low error rate:
 - repeaters spaced far apart
 - immune to electromagnetic noise

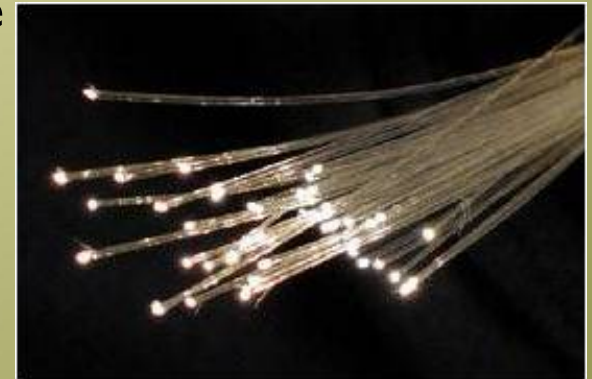
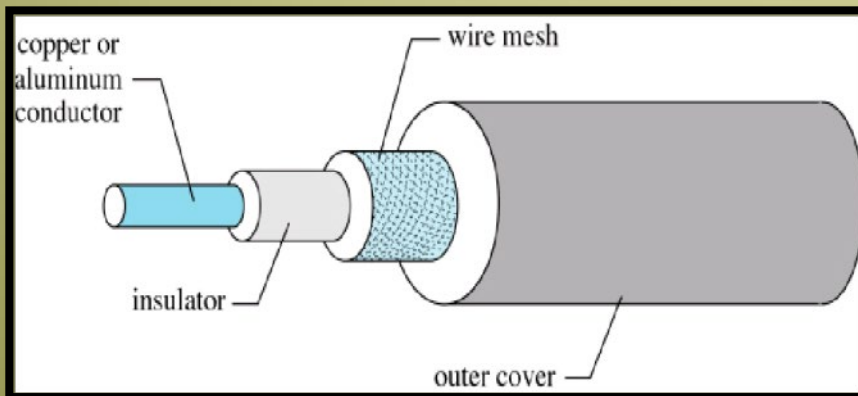

Physical media: terrestrial radio

- ❖ signal carried in electromagnetic spectrum
- ❖ no physical “wire”
- ❖ Bidirectional
- ❖ propagation environment effects:
 - reflection
 - obstruction by objects
 - interference

radio link types:

- ❖ **terrestrial microwave**
 - e.g. up to 45 Mbps channels
- ❖ **LAN** (e.g., WiFi)
 - 11 Mbps, 54 Mbps
- ❖ **wide-area** (e.g., cellular)
 - 3G cellular: ~ few Mbps

Physical media: terrestrial radio

❖ Microwave Transmissions

- Often through Horn Antenna
- Towers are used as repeaters to solve earth curvature's and signal loss problems

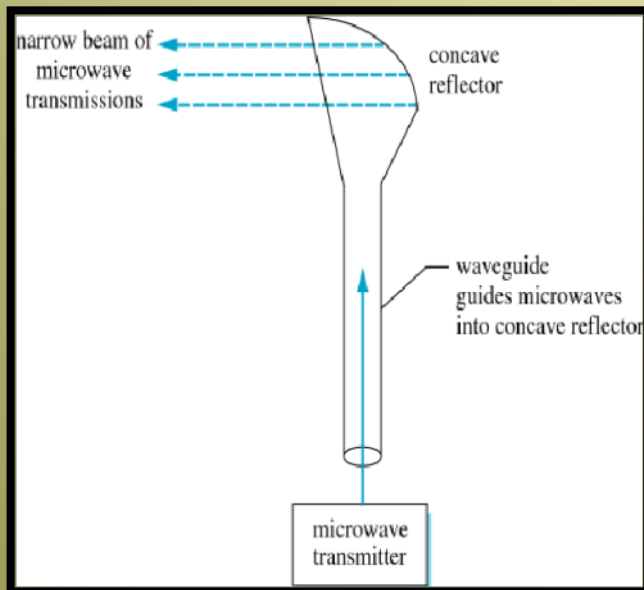

Horn Antenna

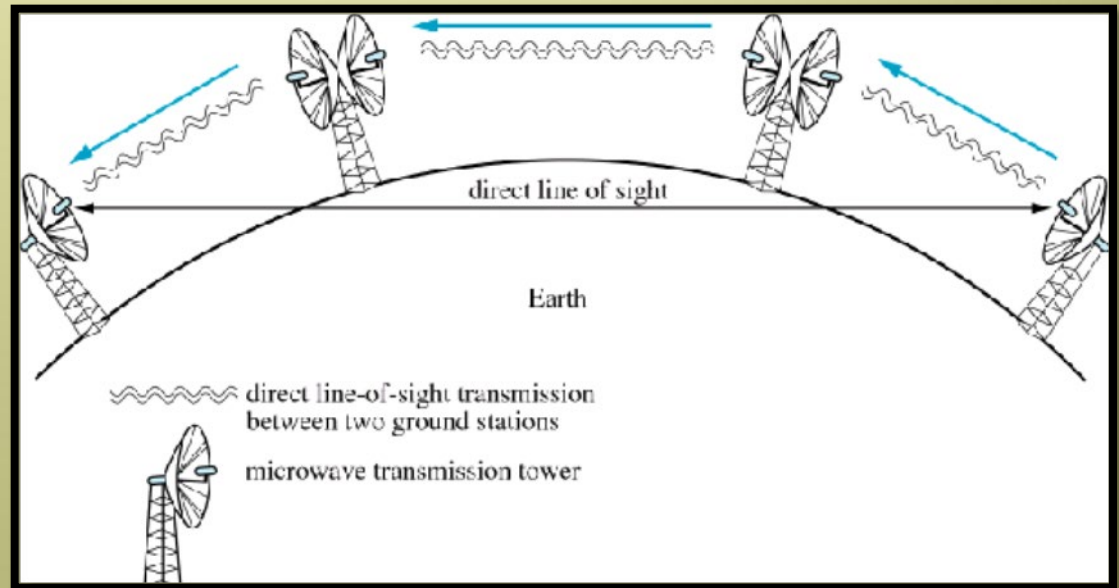

Microwave Towers as Repeaters

Physical media: satellite radio

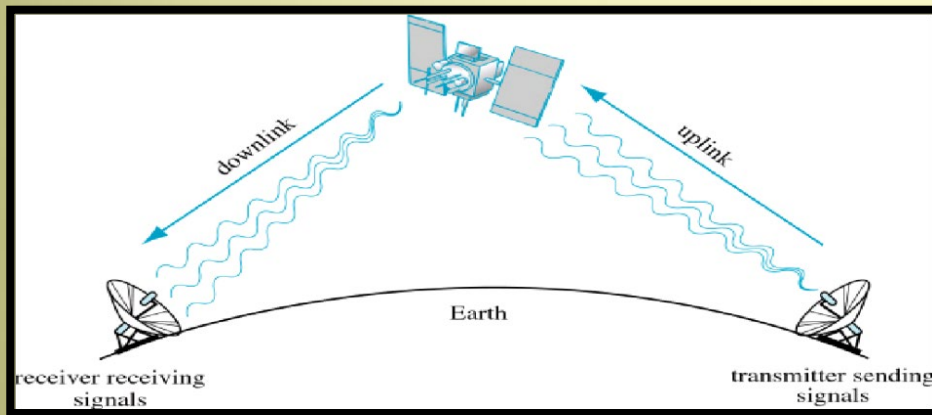

❖ satellite communications

- A science fiction in 1945; A common science today!
- Primarily, it is a microwave transmission in which one of the towers is a satellite
- In 1957, the Soviet Union launched the Sputnik
- geosynchronous versus low altitude/low-earth orbit (LEO)
- Kbps to 45Mbps channel
- 280 msec end-end delay

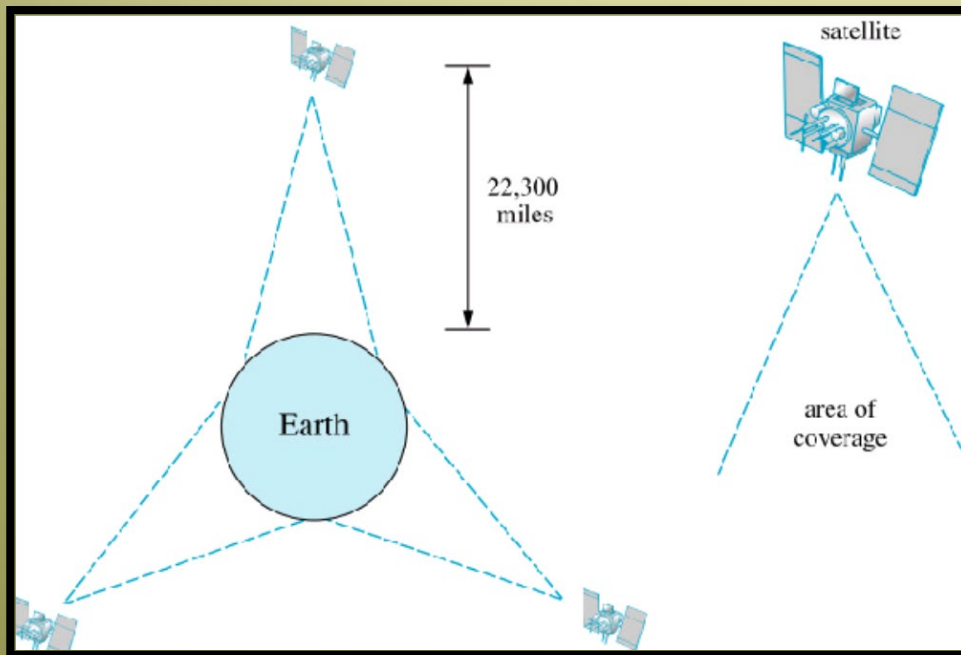

The network core

- ❖ mesh of interconnected routers

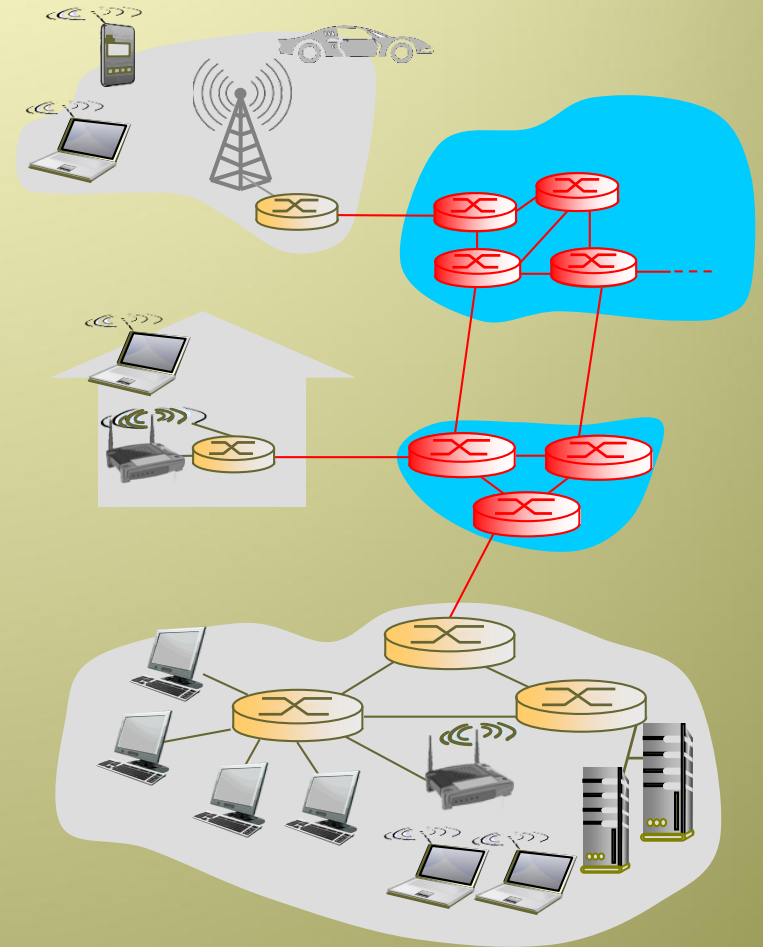

The network core

❖ message-switching:

- *Message*: unit of information
- A route is established when a message is to be sent
- A sending node attach the message along with the destination address, chooses a route, then forwards it to the first node in that route
- The message, in its entirety, is temporarily stored at that node, while logic is working the next node in the following possible route
- Once the following node is known the message is routed to it
- This is know as **Store-and-Forward**

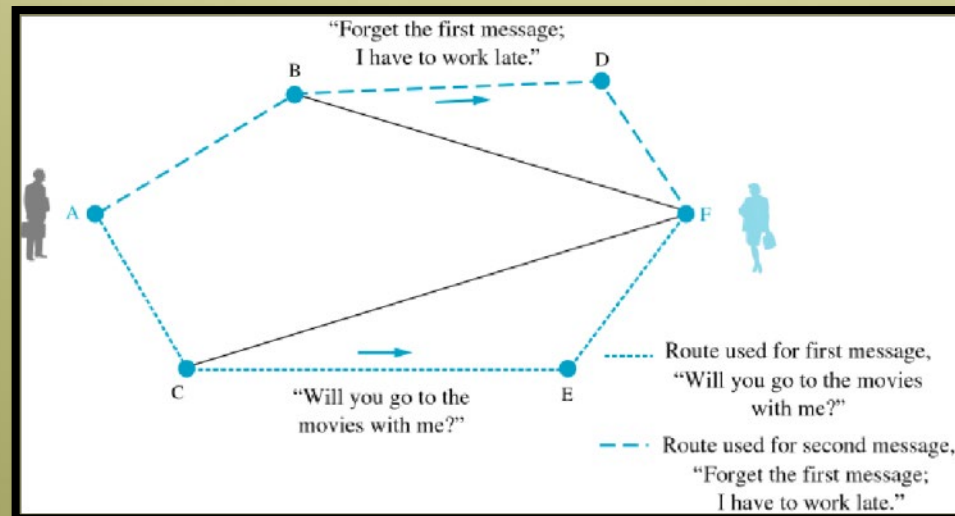

The network core

- ❖ packet-switching: hosts break application-layer messages into *packets*
 - forward packets from one router to the next, across links on path from source to destination
 - each packet transmitted at full link capacity

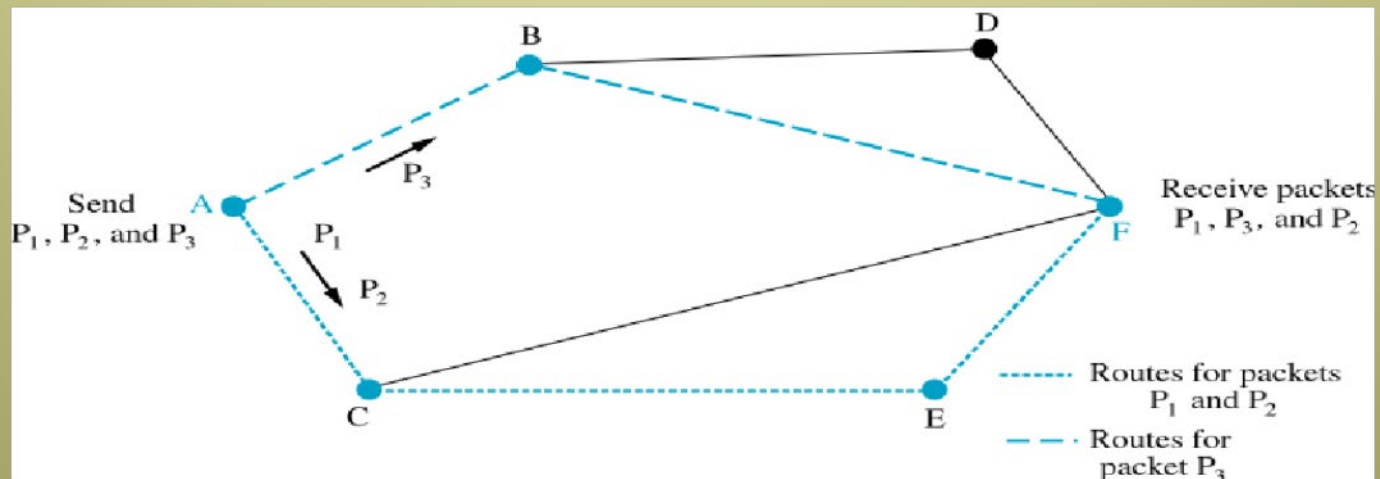

Host: sends *packets* of data

host sending function:

- ❖ takes application message
- ❖ breaks into smaller chunks, known as *packets*, of length L bits
- ❖ transmits packet into access network at *transmission rate R*
 - link transmission rate, aka link *capacity*, aka *link bandwidth*

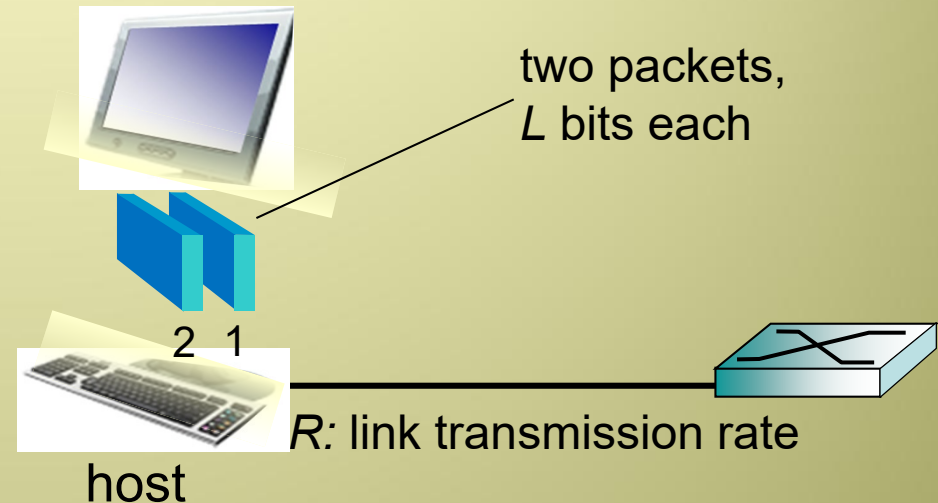

$$\text{packet transmission delay} = \text{time needed to transmit } L\text{-bit packet into link} = \frac{L \text{ (bits)}}{R \text{ (bits/sec)}}$$

Packet-switching: store-and-forward

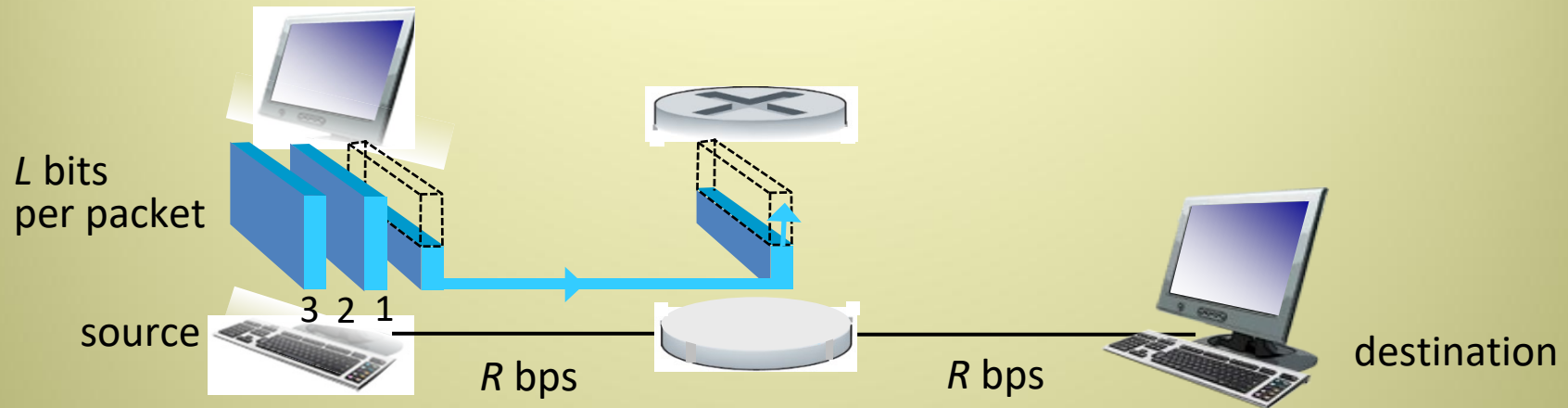

- ❖ takes L/R seconds to transmit (push out) L -bit packet into link at R bps
- ❖ *store and forward*: entire packet must arrive at router before it can be transmitted on next link
- ❖ end-end delay = $2L/R$ (assuming zero propagation delay)

- one-hop numerical example:*
- $L = 7.5$ Mbits
 - $R = 1.5$ Mbps
 - one-hop transmission delay = 5 sec
- } more on delay shortly ...

Packet-switching: store-and-forward

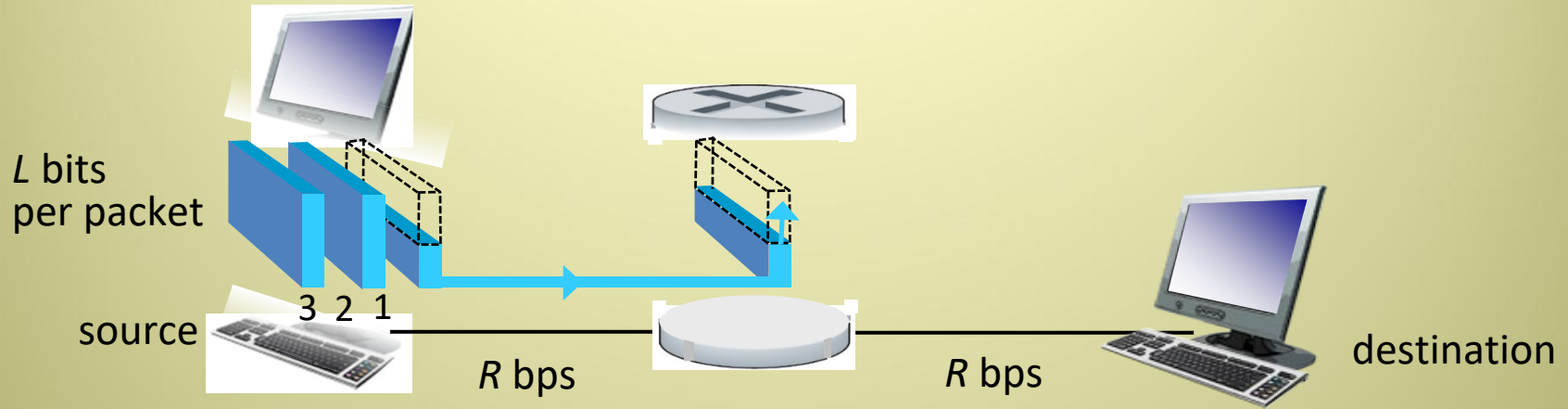

- ❖ takes $4L/R$ seconds to receive all 3 packets
- ❖ In the general case, sending one packet through N links ($N-1$ connecting routers) would cost an end-to-end delay as follows:

$$d_{\text{end-to-end}} = N L/R$$

(again, this is assuming zero propagation delay)

Packet Switching: queueing delay, loss

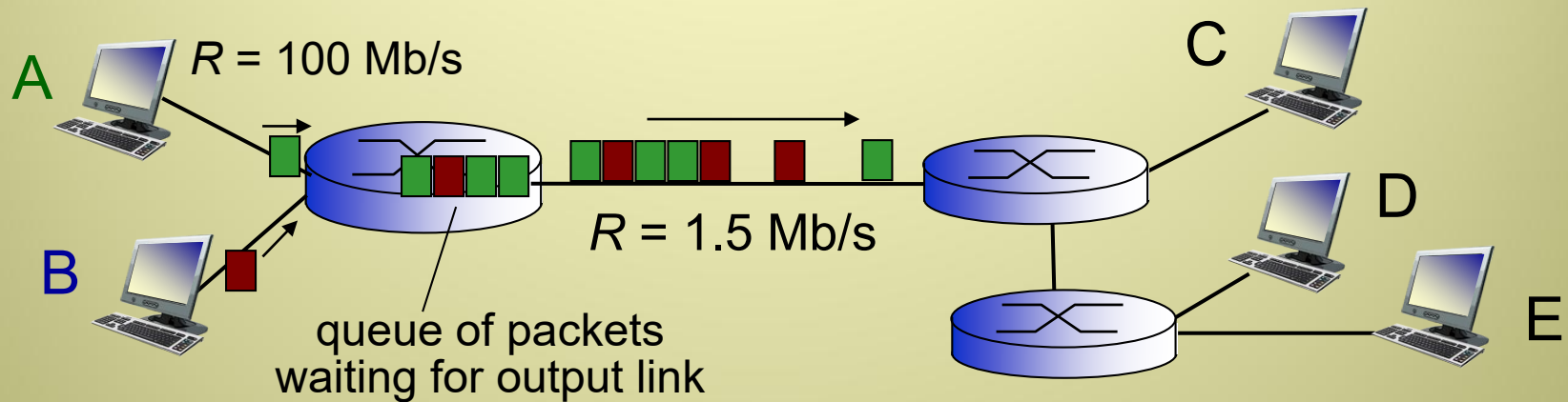

queueing delay and loss:

- ❖ If arrival rate (in bits) to link exceeds transmission rate of link for a period of time:
 - packets will queue, wait to be transmitted on link, consequently causing delays
 - packets can be dropped (lost) if memory (buffer) fills up

Packet Switching: Virtual circuit vs Datagram

- ❖ Packet switching has two common routing methods
 - **Datagram**
 - **Virtual circuit**
- ❖ Sending through different routes is flexible; why?
- ❖ However, packets may arrive out of order!
- ❖ With virtual circuit, network protocols establish a route (virtual circuit) before sending any packets.
- ❖ Consequently, packets are guaranteed to arrive in order
- ❖ **Important Note: The circuit is not dedicated**

Two key network-core functions

routing: determines source-destination route taken by packets

- *routing algorithms*

forwarding: move packets from router's input to appropriate router output

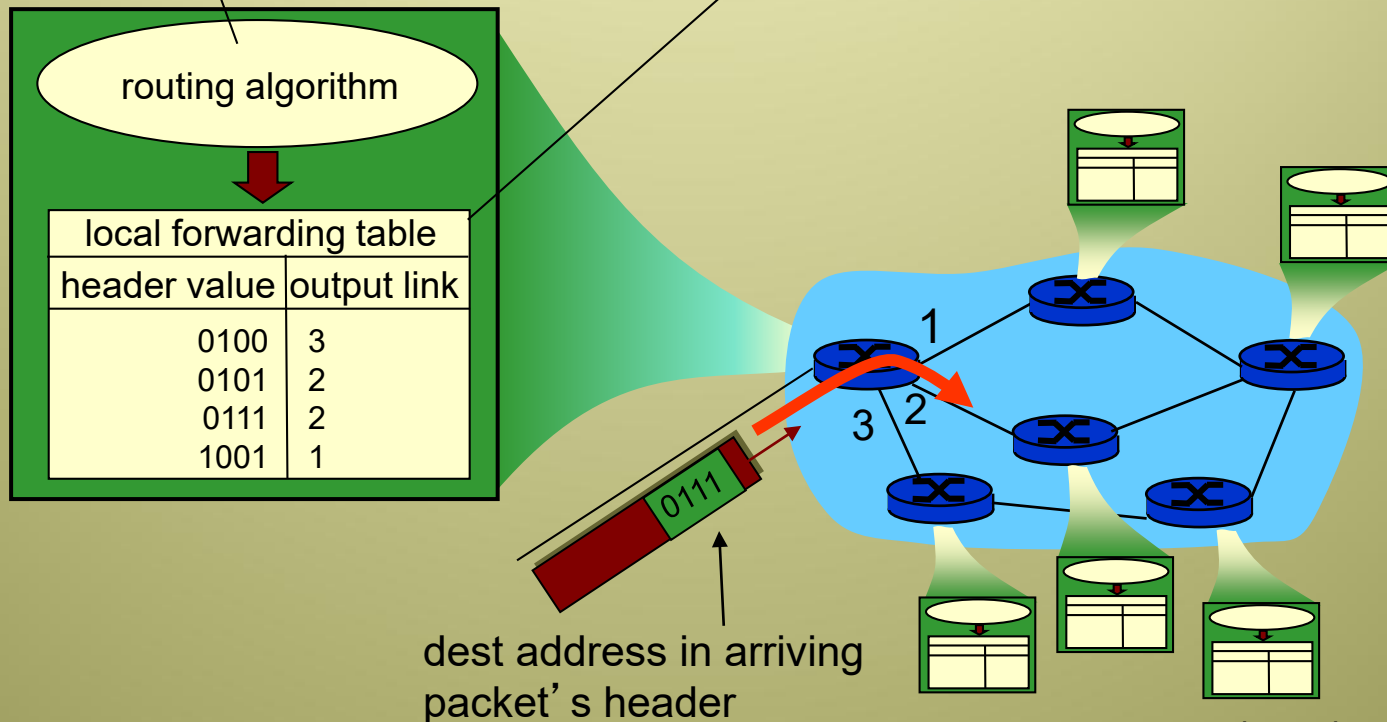

Alternative core: circuit switching

end-end resources allocated to, reserved for, “call” between source & dest:

- ❖ In diagram below, each link has four circuits.
 - call gets 2nd circuit in top link and 1st circuit in right link.
- ❖ dedicated resources: no sharing
 - circuit-like (guaranteed) performance
- ❖ circuit segment idle if not used by call (*no sharing*)
- ❖ Commonly used in traditional telephone networks

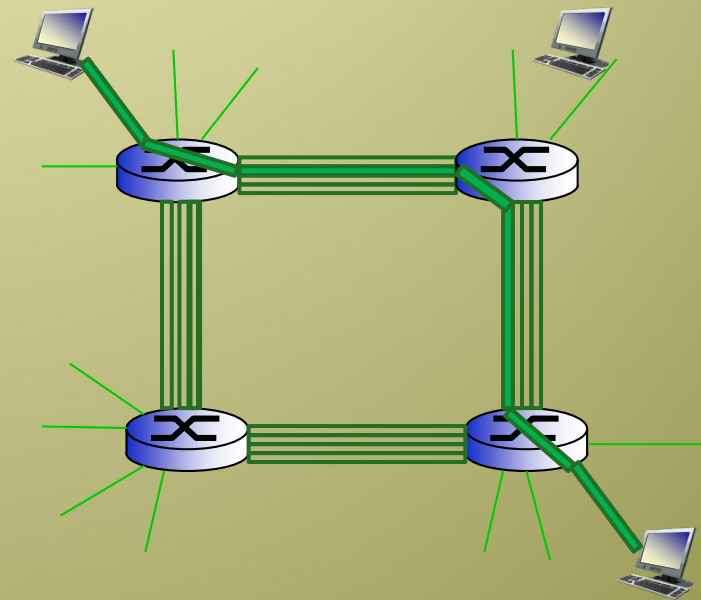
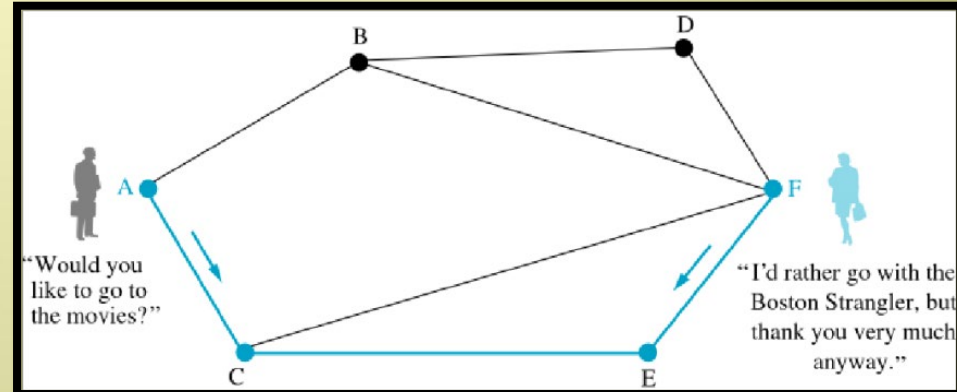

Bit rate & Bandwidth

❖ Bit Rate

- How many **bits per second** (bps) a link can transmit
- Rates range from 100s bps to billions of bps (gigabits) and now pushing for trillion bps (terabit)

❖ Bandwidth

- **Period:** Time needed for a signal to complete one cycle
- **Frequency:** Number of cycles per second, measured in **Hertz** (Hz)

$$f = 1 / p$$

- For example, if $p = 0.5$ microseconds (μsec) then $f = 2$ MHz
- A given medium can accommodate a range of frequency
- **Bandwidth** is the difference between the highest and the lowest possible frequency that can be transmitted
- For example, telephone signals can handle frequencies between 300 Hz & 3300Hz; the bandwidth is hence 3000 Hz
- In other words, very high or very low audible sounds cannot pass through the telephone

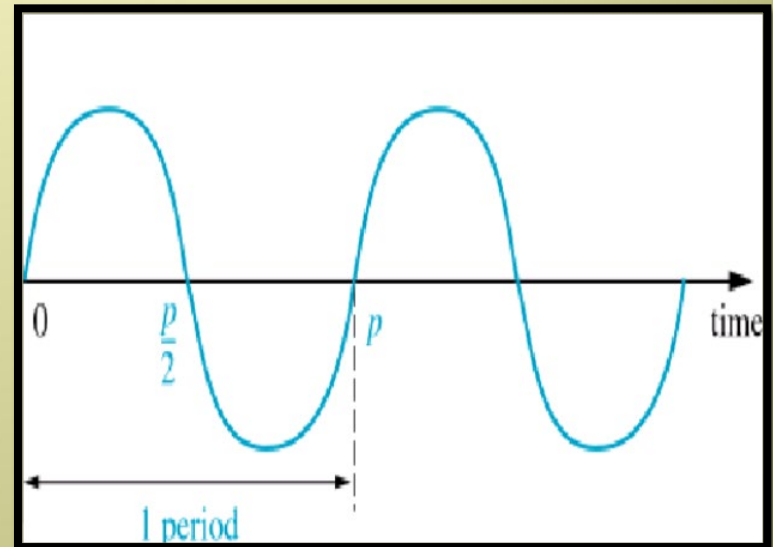

Multiplexing: FDM versus TDM

FDM

Example:

4 users

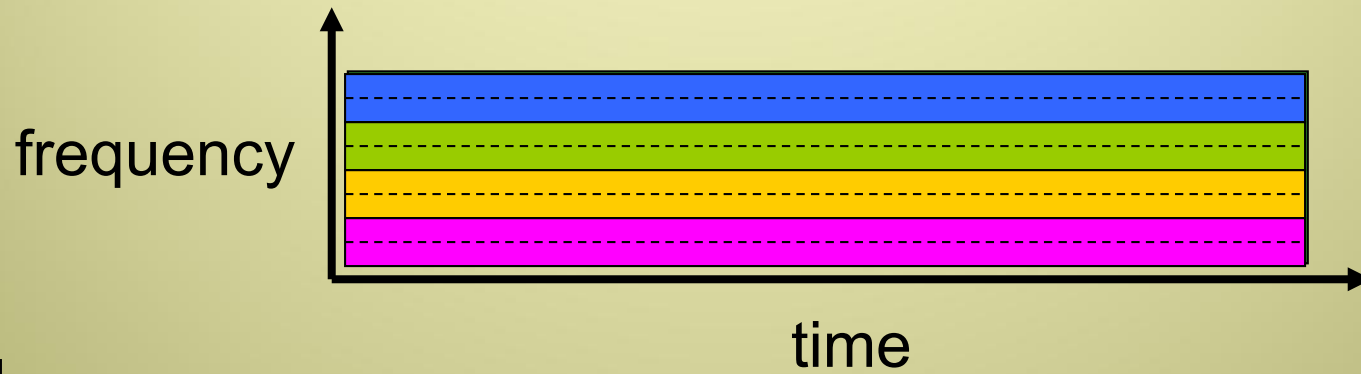

TDM

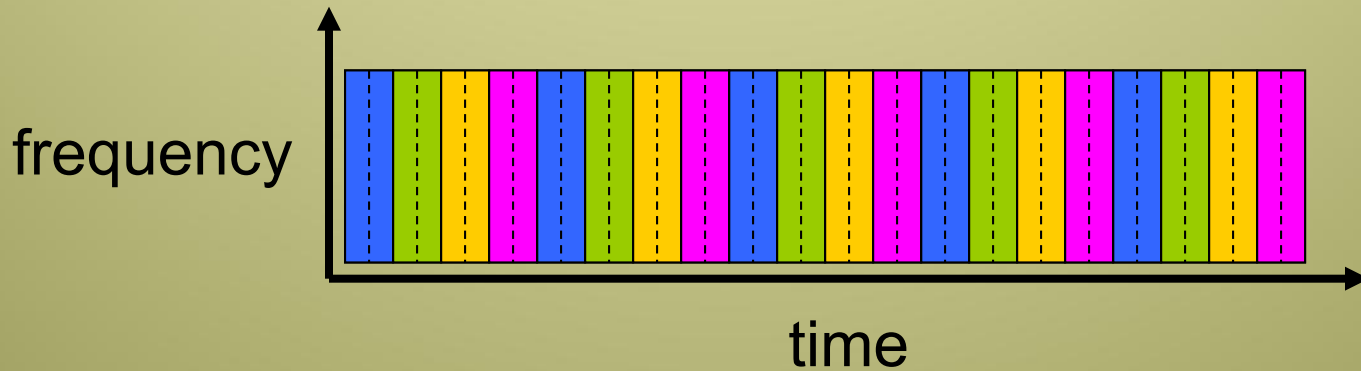

Frequency-Division Multiplexing (FDM)

- ❖ The signals from all inputs are combined into as a single, more complex analog signal
- ❖ The channels themselves are separated by a **guard band**

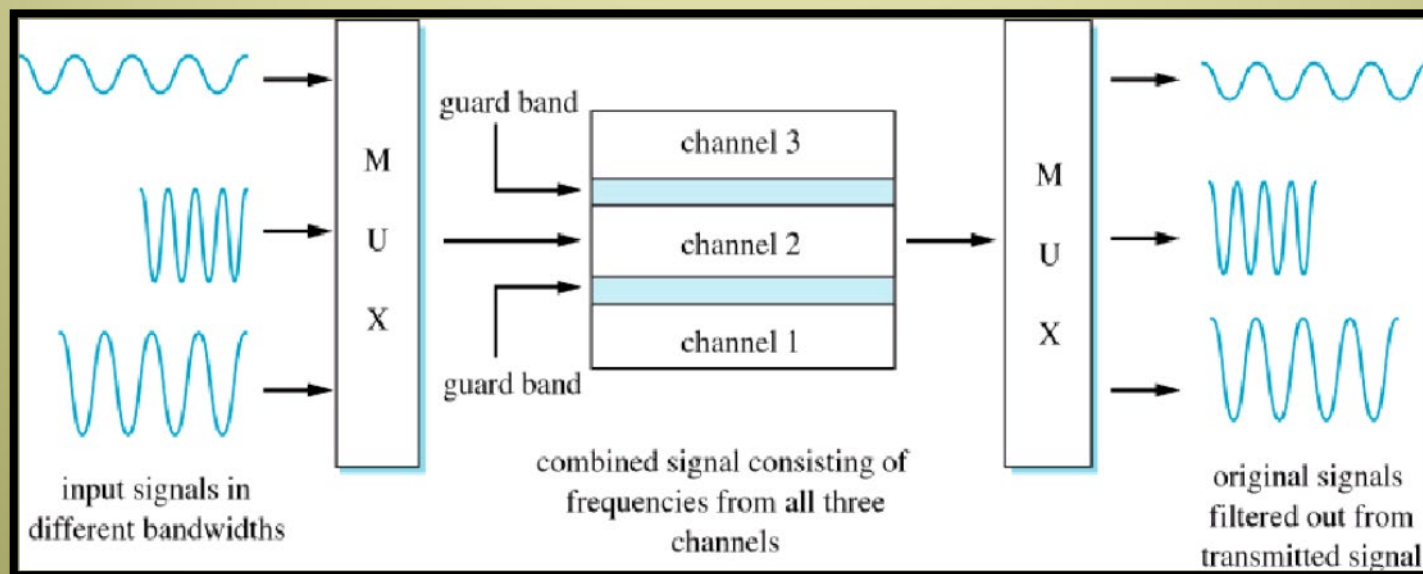

Time-Division Multiplexing (TDM)

- ❖ TDM keeps the signals physically distinct but logically packages them together
- ❖ The optimal performance is achieved when the combined input rate is equal to the output rate
- ❖ A faster combined input rate would result in signals being dropped and a slower input rate would result in frames that are partially full so the channels are underused

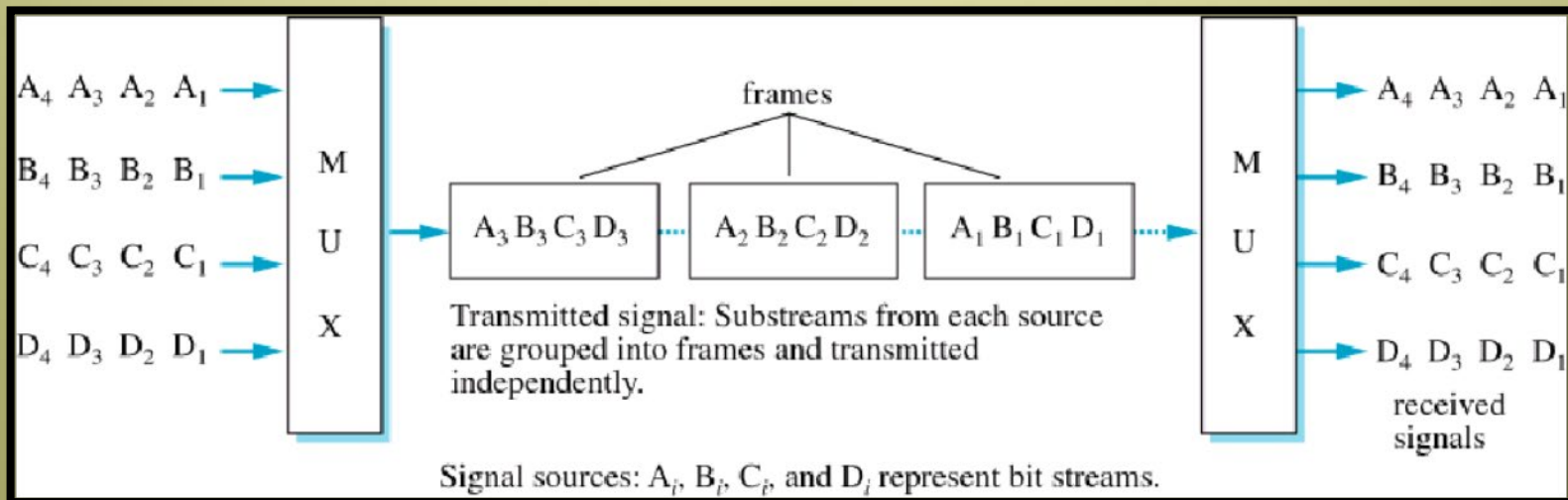

Time-Division Multiplexing (TDM)

T1/DS1 Digital Carrier

- ❖ A standard used for long-distance communication
- ❖ Uses TDM to combine many voice channels into one Digital Signal 1 (**DS1**) frame
- ❖ *T1* refers to the circuit, *DS1* refers to the signal
- ❖ DS1 frame has 24 channels of 8 bits each, and one framing bit for synchronization

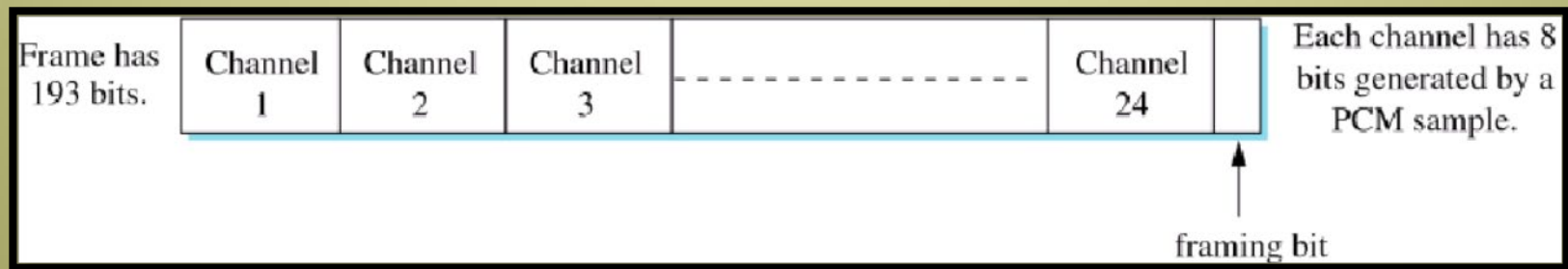

DS1 Frame

Time-Division Multiplexing (TDM)

T1/DS1 Digital Carrier

- ❖ T1 rate:
 - 8-bit sample * 8000 samples/second → 64 Kbps
 - To support this rate, T1 must transmit a DS1 frame each 1/8000 seconds → must transmit 8000 * 193 bits each second
 - → Data rate of 1.544 Mbps (1.536 Mbps of actual data)
- ❖ This rate is considered slow compared to optical fiber capabilities
- ❖ That is the reason there are other carriers with more channels and faster bit rate
- ❖ T1 is not only used for voice communication; other companies lease phone lines to transfer digital information between computers

Carrier	Digital Signal No.	No. of Channels	Bit Rate, Mbps
T1	DS1	24	1.544
T2	DS2	96	6.312
T3	DS3	672	44.736
T4	DS4	4,032	274.176

Time-Division Multiplexing (TDM)

Example

- ❖ Assume a TDM with 24 slots TDM and a bit rate of 1.536 Mbps.
- ❖ Assume also that end-to-end circuit establishment requires 500 ms.
- ❖ How much time is needed to send a file of size 960 Kbits?
 - Each circuit is capable of transmitting $1.536 \text{ Mbps}/24 = \mathbf{64 \text{ kbps}}$
 - To send 960 kbits it requires: $960 \text{ kbits}/64 \text{ kbps} = \mathbf{15 \text{ seconds}}$
 - Total time needed to send the file: $\mathbf{15.5 \text{ seconds}}$

Packet switching versus circuit switching

packet switching allows more users to use network!

example:

- 1 Mb/s link
- each user:
 - 100 kb/s when “active”
 - active 10% of time

❖ *circuit-switching:*

- 10 users

❖ *packet switching:*

- with 35 users, probability > 10 active at same time is found to be less than .0004 *
- probability of ≤ 10 active users at the same time is .9996 \rightarrow packet switching provides essentially the same performance of circuit switching while allowing more than 3 times the number of users

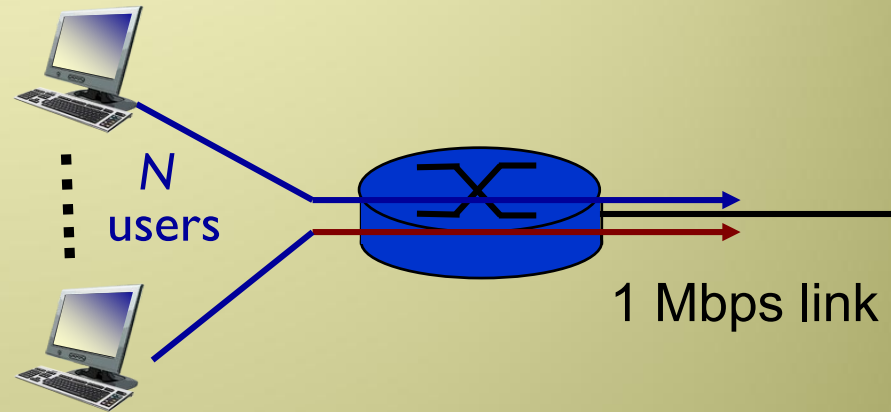

Q: what happens if > 35 users ?

- Proof is irrelevant and beyond the scope of this coverage

Packet switching versus circuit switching

So, is packet switching a “slam dunk winner”?

- ❖ great for bursty data
 - resource sharing
 - simpler, no call setup
- ❖ **excessive congestion possible:** packet delay and loss
 - protocols needed for reliable data transfer, congestion control
- ❖ **Q: How to provide circuit-like behavior?**
 - bandwidth guarantees needed for audio/video apps
 - still an unsolved problem (will be discussed later in details)

Internet structure: network of networks

- ❖ End systems connect to Internet via **access ISPs** (Internet Service Providers)
 - Residential, company and university ISPs
- ❖ Access ISPs in turn must be interconnected.
 - ❖ So that any two hosts can send packets to each other
- ❖ Resulting network of networks is very complex
 - ❖ Evolution was driven by **economics** and **national policies**
- ❖ Let's take a stepwise approach to describe current Internet structure

Internet structure: network of networks

Question: given *millions* of access ISPs, how to connect them together?

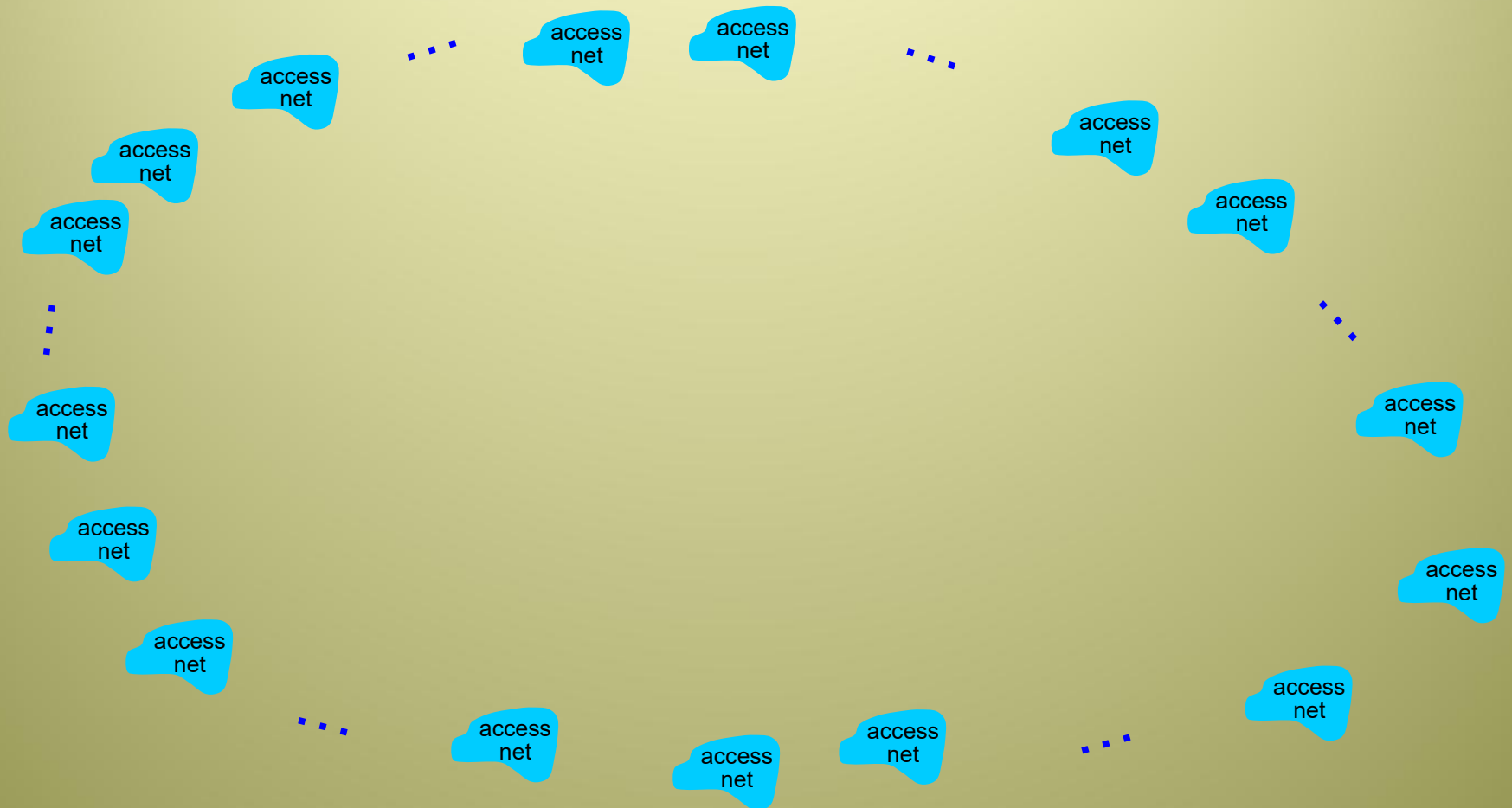

Internet structure: network of networks

Option: connect each access ISP to every other access ISP?

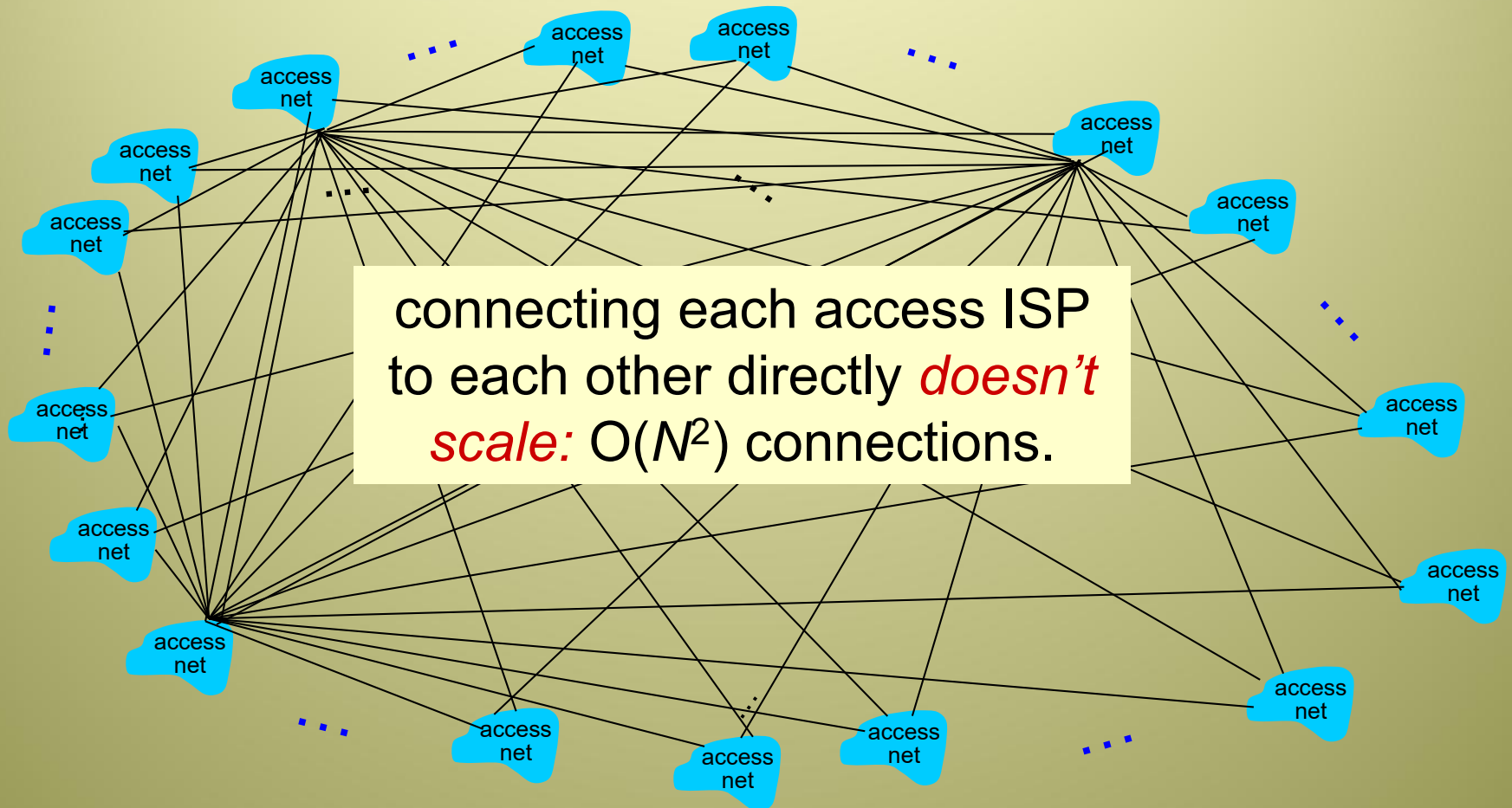

Internet structure: network of networks

Option: connect each access ISP to a global transit ISP? Customer and provider ISPs have economic agreement.

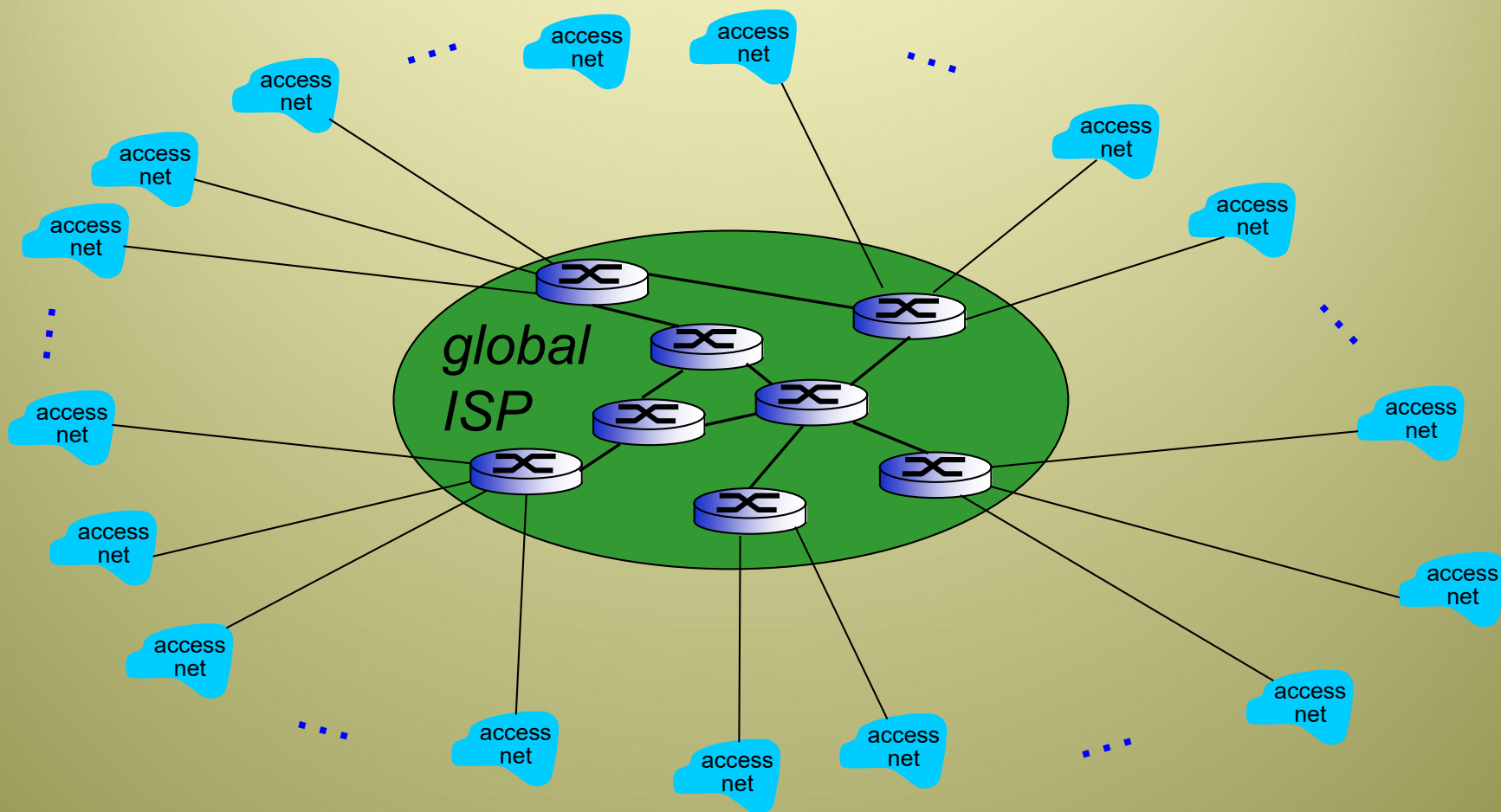

Internet structure: network of networks

But if one global ISP is viable business, there will be competitors

....

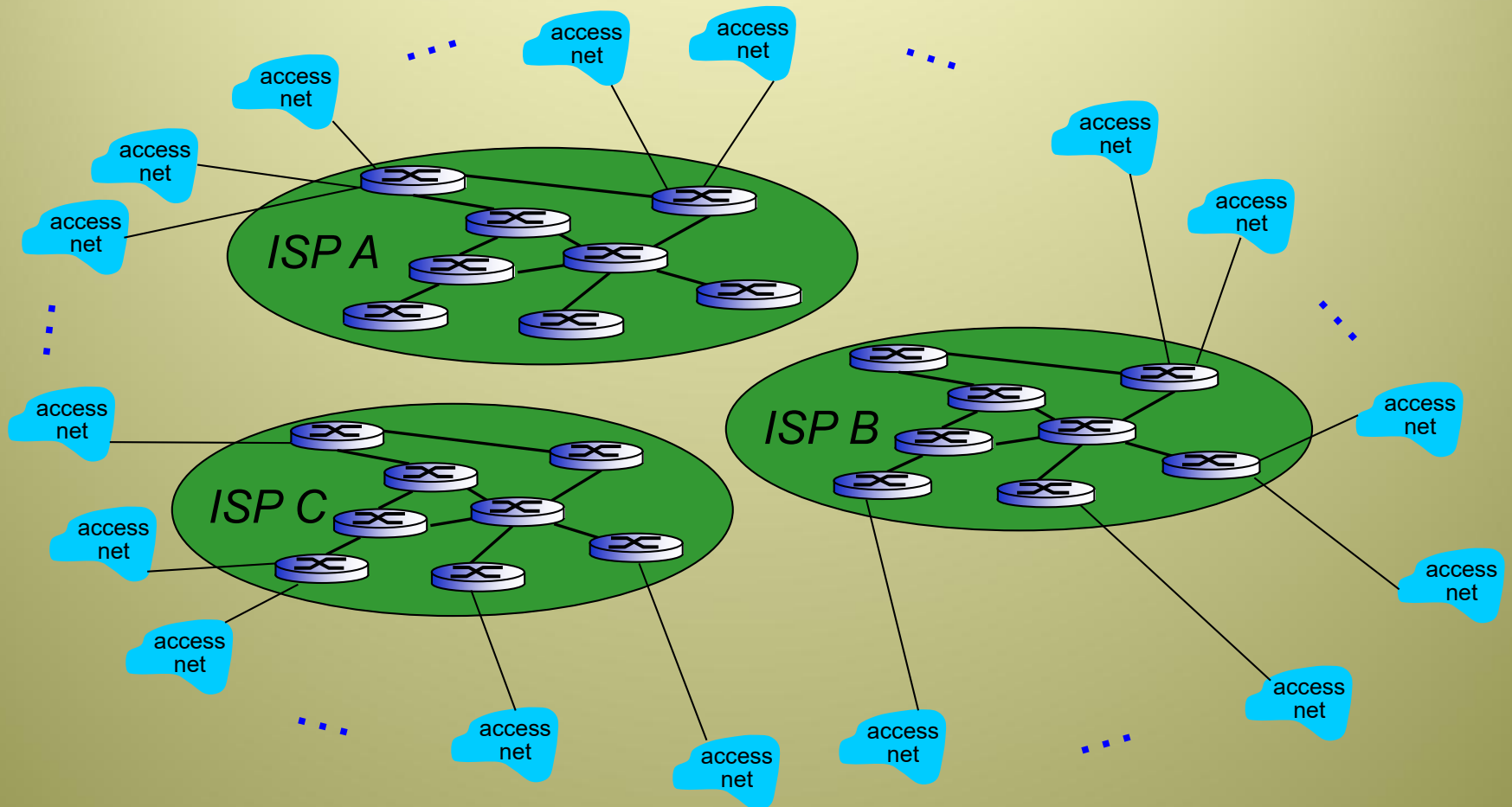

Internet structure: network of networks

But if one global ISP is viable business, there will be competitors
.... which must be interconnected; leading to a 2-tier hierarchy

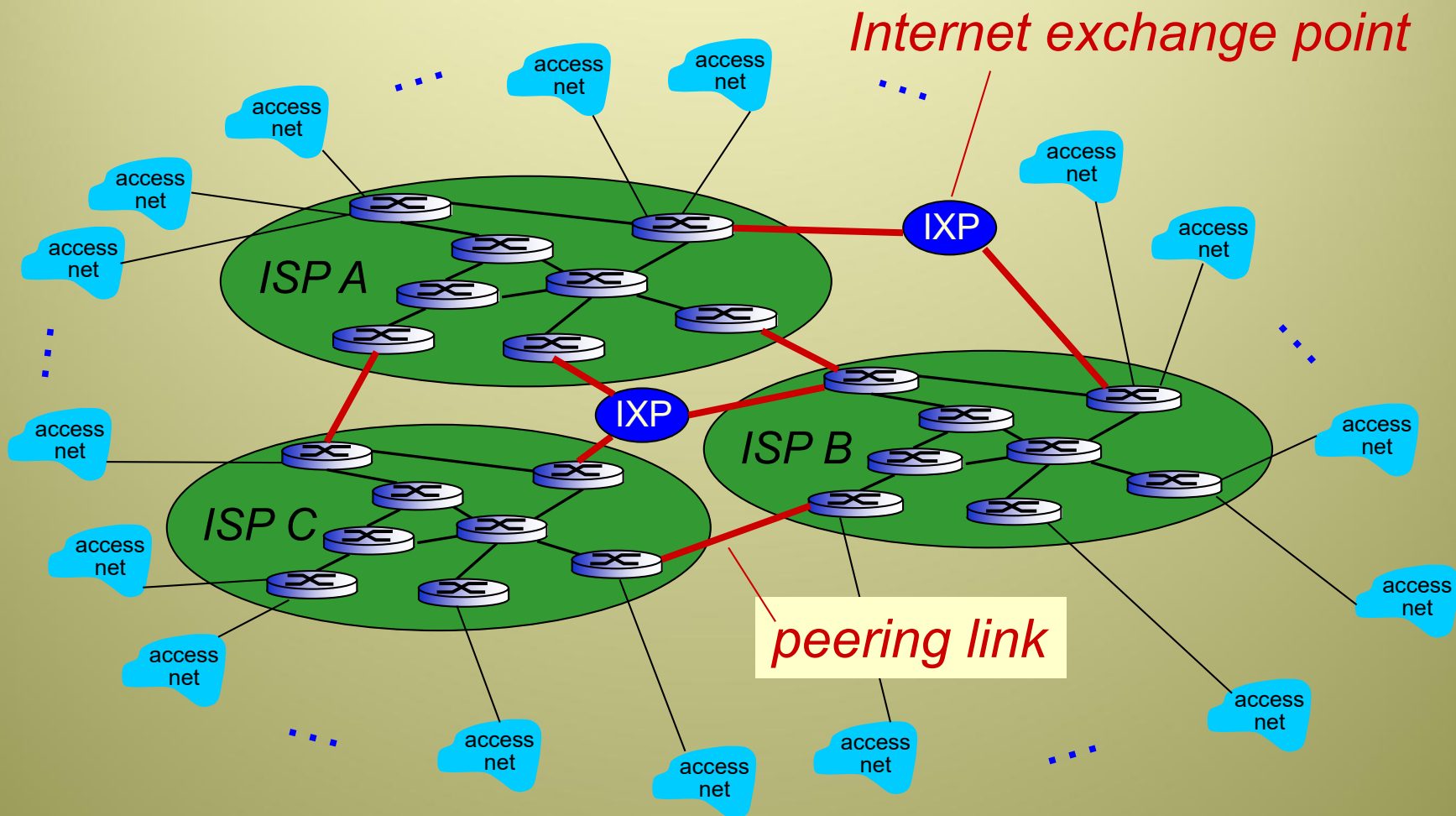

Internet structure: network of networks

... and regional networks may arise to connect access nets to ISPs

- PoPs and multi-home are possible

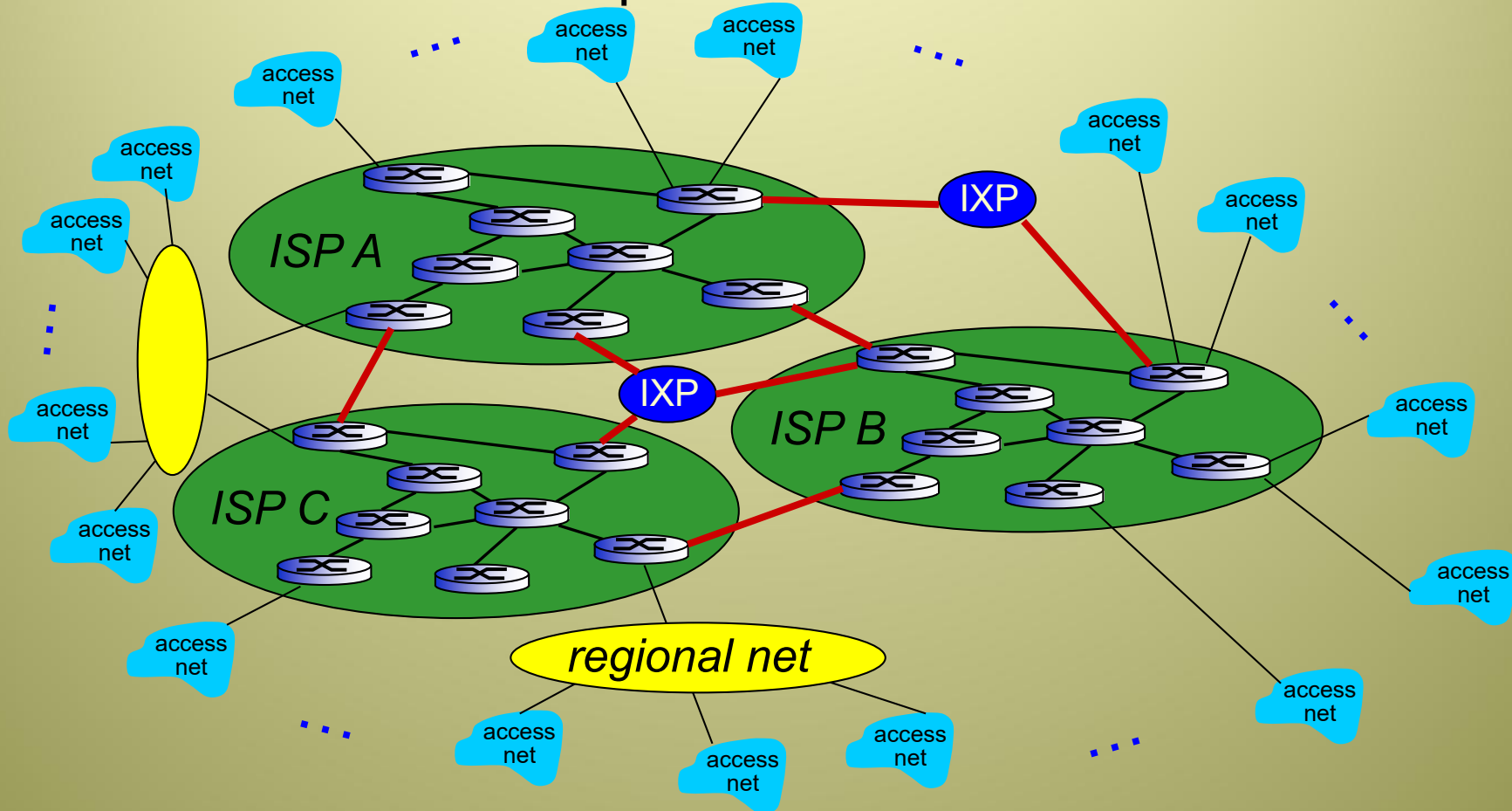

Internet structure: network of networks

... and content provider networks (e.g., Google, Microsoft, Akamai) may run their own network, to bring services, content close to end users

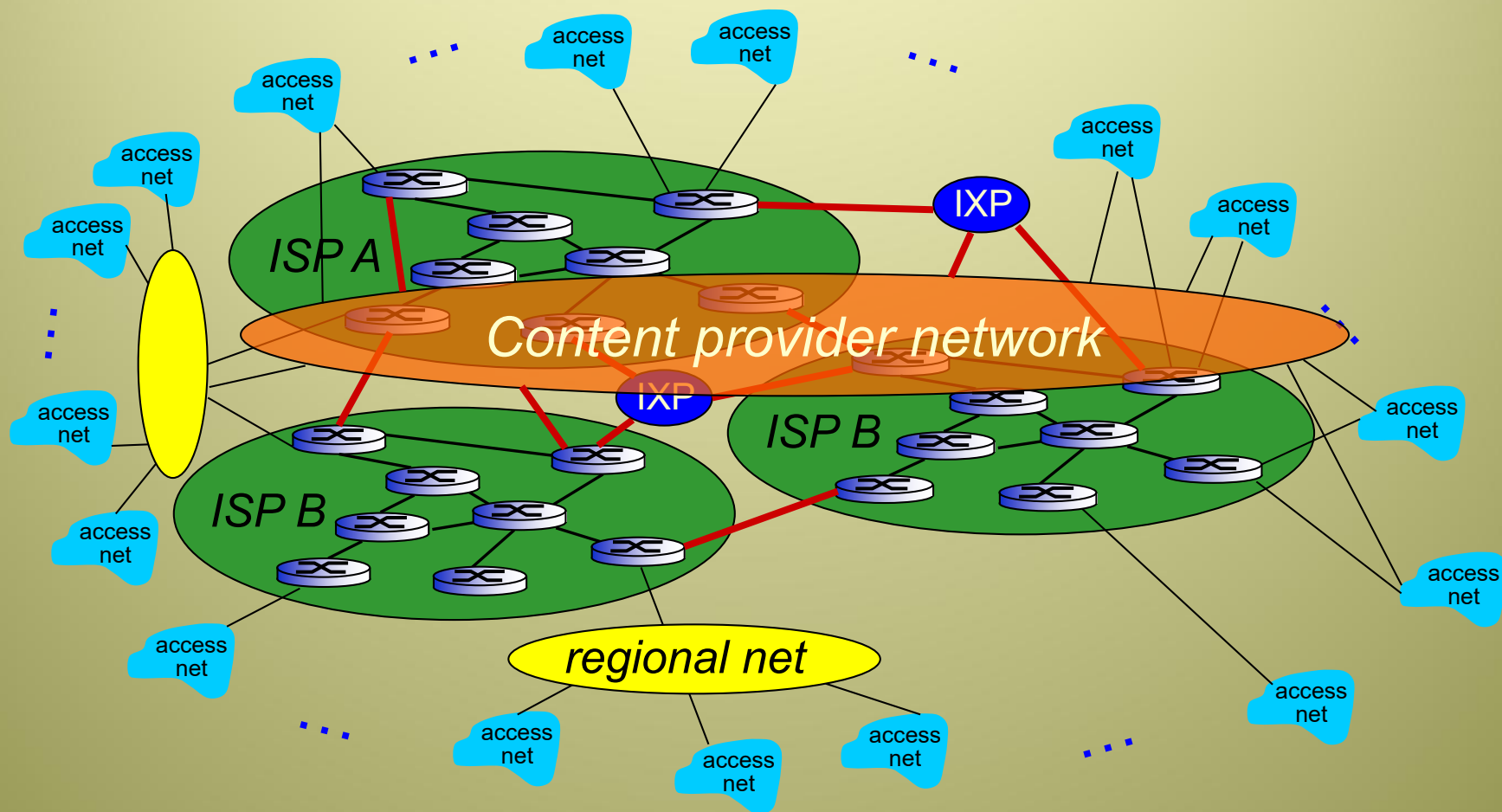

The 2021 Internet structure

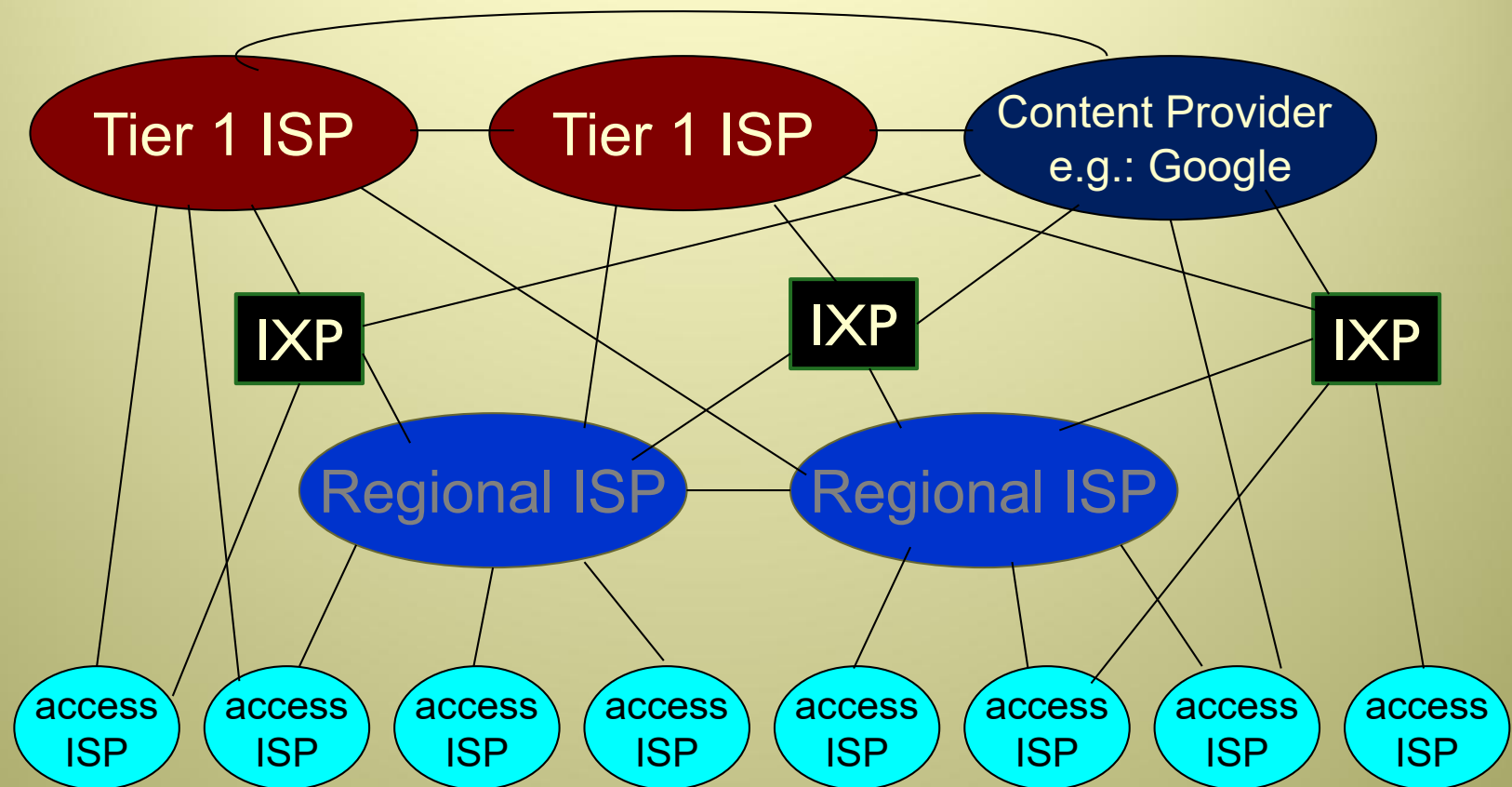

- ❖ at center: small # of well-connected large networks
 - “tier-1” commercial ISPs (e.g., Level 3, Sprint, AT&T, NTT), national & international coverage
 - content provider network (e.g, Google): private network that connects it data centers to Internet, often bypassing tier-1, regional ISPs

Tier-1 ISP: e.g., Sprint

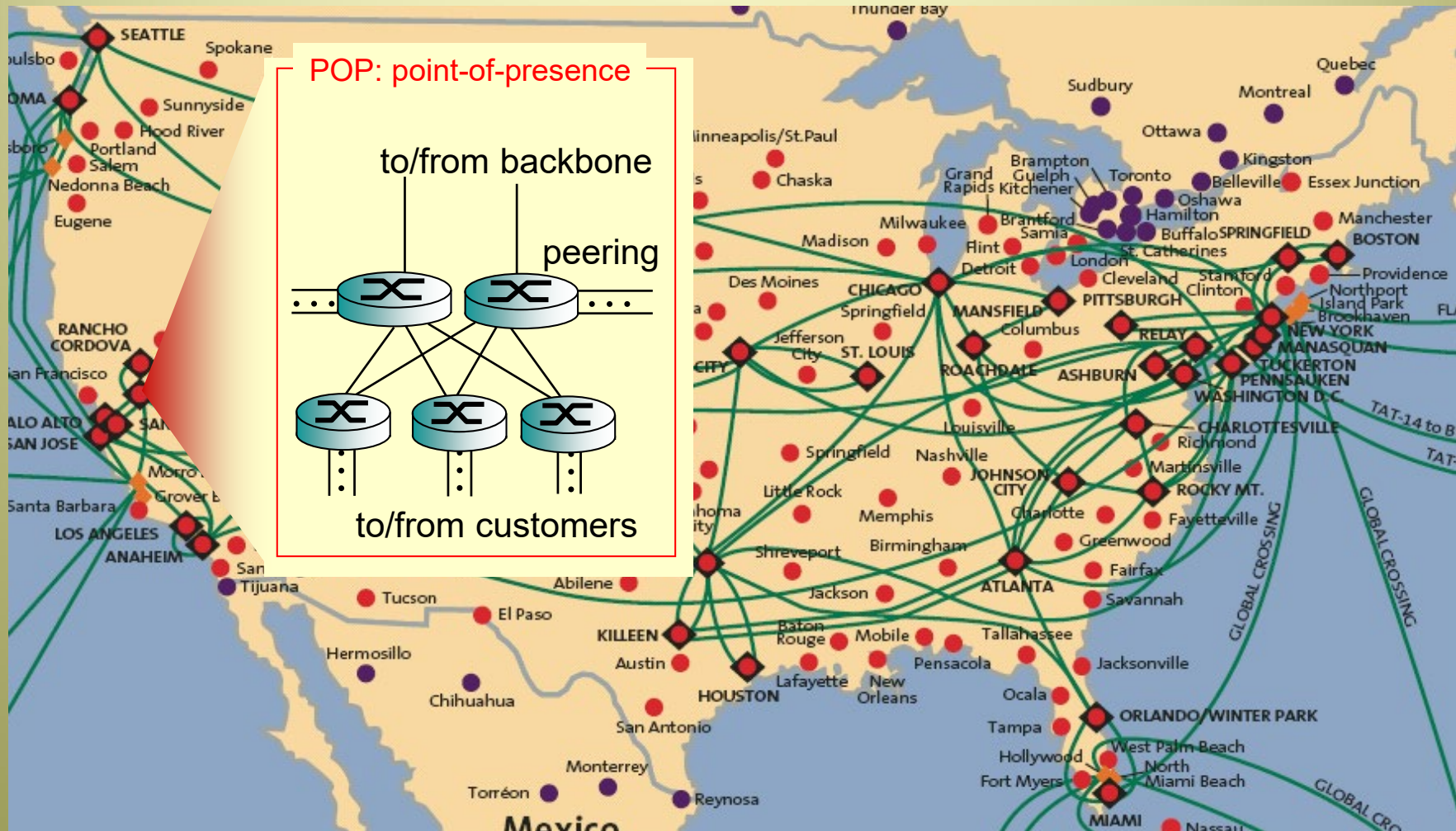

How do loss and delay occur?

packets *queue* in router buffers

- ❖ packet arrival rate to link (temporarily) exceeds output link capacity
- ❖ packets queue, wait for turn

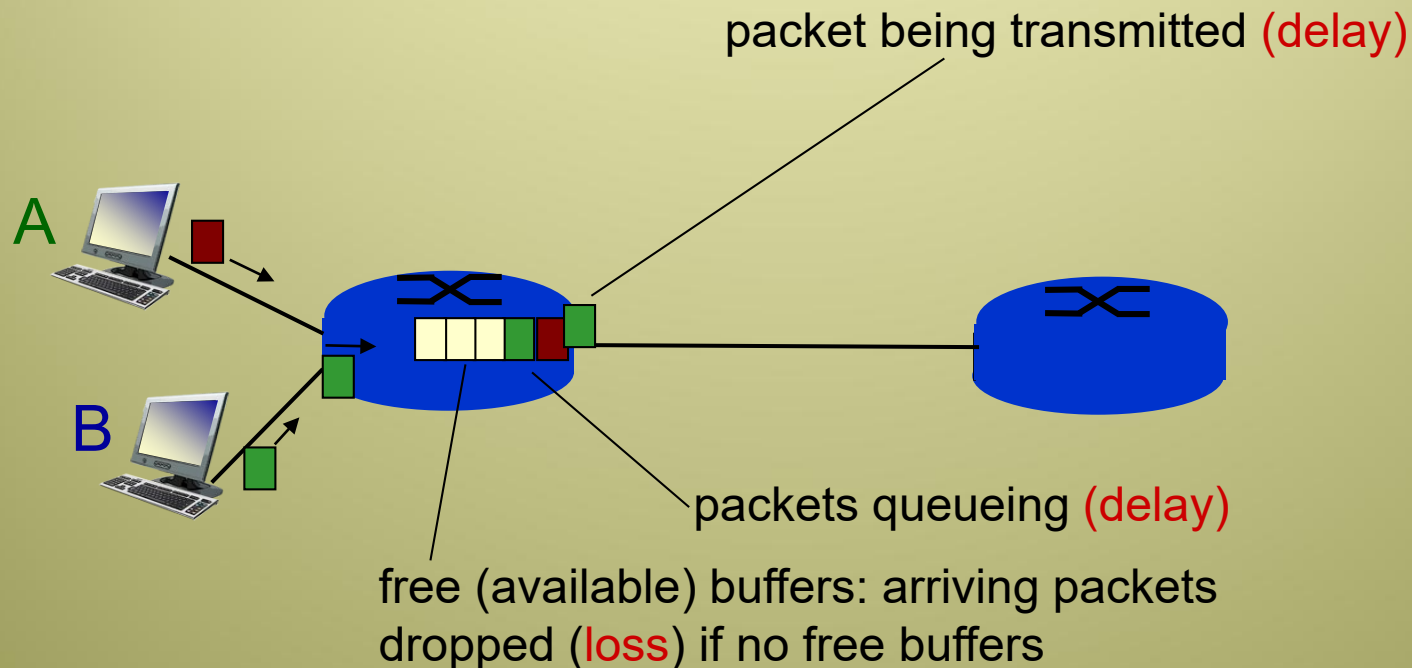

Four sources of packet delay

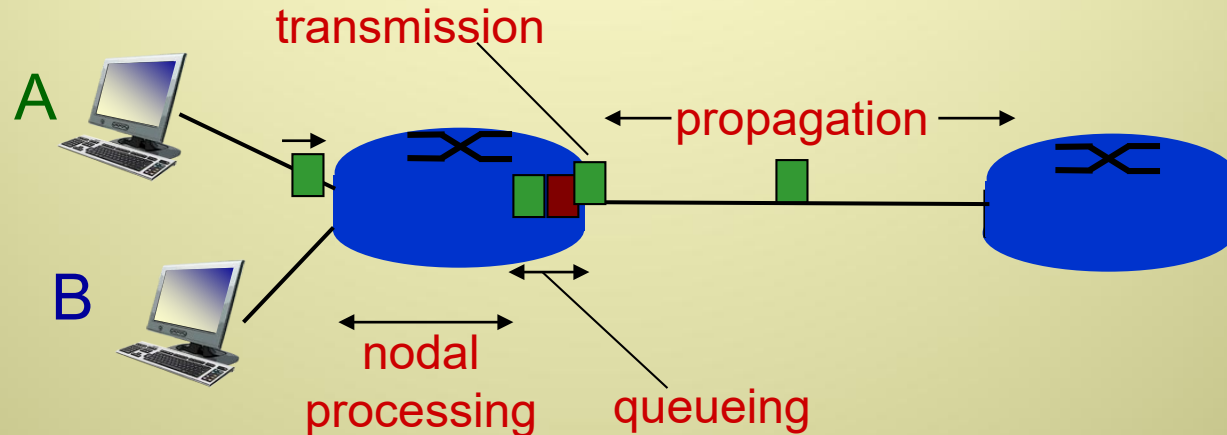

$$d_{\text{nodal}} = d_{\text{proc}} + d_{\text{queue}} + d_{\text{trans}} + d_{\text{prop}}$$

d_{nodal} : total nodal delay

d_{proc} : nodal processing

- check bit errors
- determine output link
- typically $< \mu\text{sec}$

d_{queue} : queueing delay

- time waiting at output link for transmission
- depends on congestion level of router

Four sources of packet delay

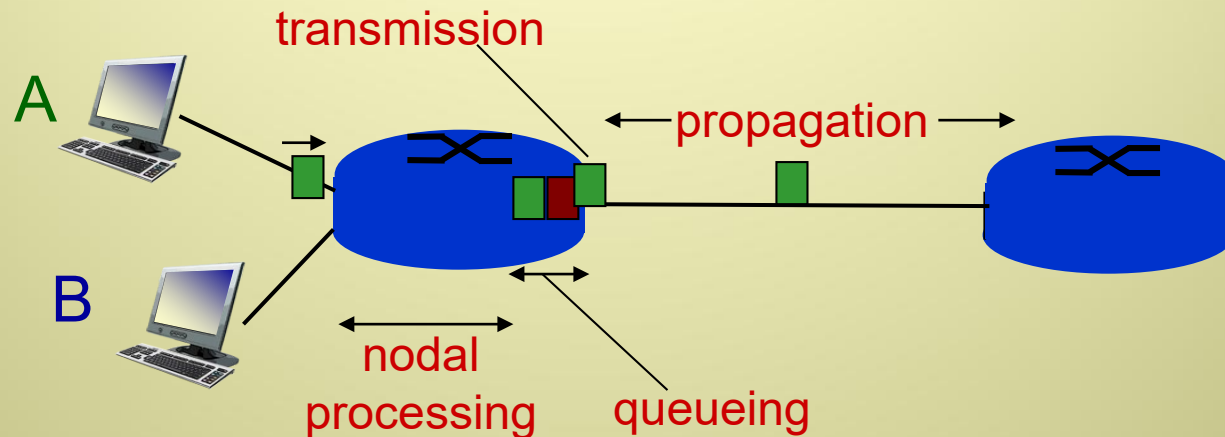

$$d_{\text{nodal}} = d_{\text{proc}} + d_{\text{queue}} + d_{\text{trans}} + d_{\text{prop}}$$

d_{trans} : transmission delay:

- L : packet length (bits)
- R : link bandwidth (bps)
- $d_{\text{trans}} = L/R$

d_{prop} : propagation delay:

- d : length of physical link
- s : propagation speed in medium ($\sim 2 \times 10^8$ m/sec)
- $d_{\text{prop}} = d/s$

d_{trans} and d_{prop}
very different

Caravan analogy

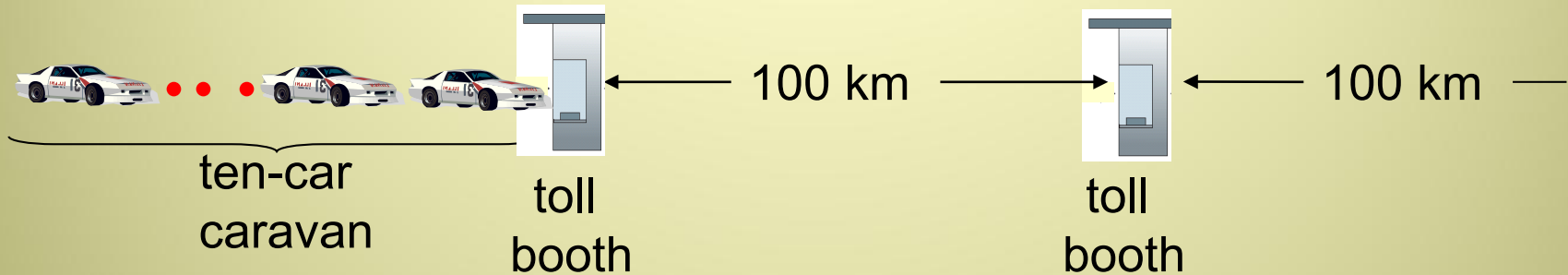

- ❖ cars “propagate” at 100 km/hr
- ❖ toll booth takes 12 sec to service car (bit transmission time)
- ❖ car ~ bit; caravan ~ packet
- ❖ **Q: How long until caravan is lined up before 2nd toll booth?**
- time to “push” entire caravan through toll booth onto highway = $12 * 10 = 120$ sec
- time for last car to propagate from 1st to 2nd toll booth: $100\text{km} / (100\text{km/hr}) = 1$ hr
- **A: 62 minutes**

Caravan analogy (more)

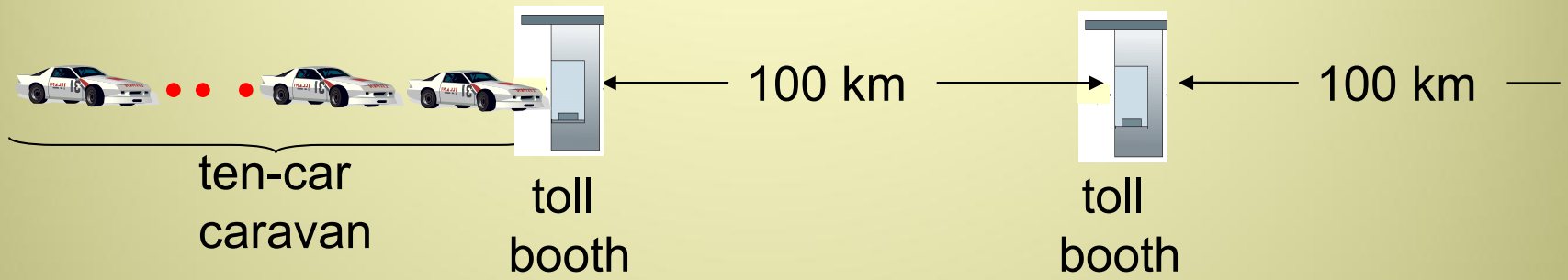

- ❖ suppose cars now “propagate” at 1000 km/hr
- ❖ and suppose toll booth now takes 60 seconds to service a car
- ❖ **Q: Will cars arrive to 2nd booth before all cars serviced at first booth?**
 - **A: Yes!** after 7 min, 1st car arrives at second booth; three cars still at 1st booth.

Queueing delay (revisited)

- ❖ R : link bandwidth (bps)
- ❖ L : packet length (bits)
- ❖ a : average packet arrival rate (# of packets/sec)
- ❖ **Traffic intensity: La/R**
- ❖ $La/R \sim 0$: avg. queuing delay small
- ❖ $La/R \rightarrow 1$: avg. queuing delay large
- ❖ $La/R > 1$: more “work” arriving than can be serviced, average delay infinite!

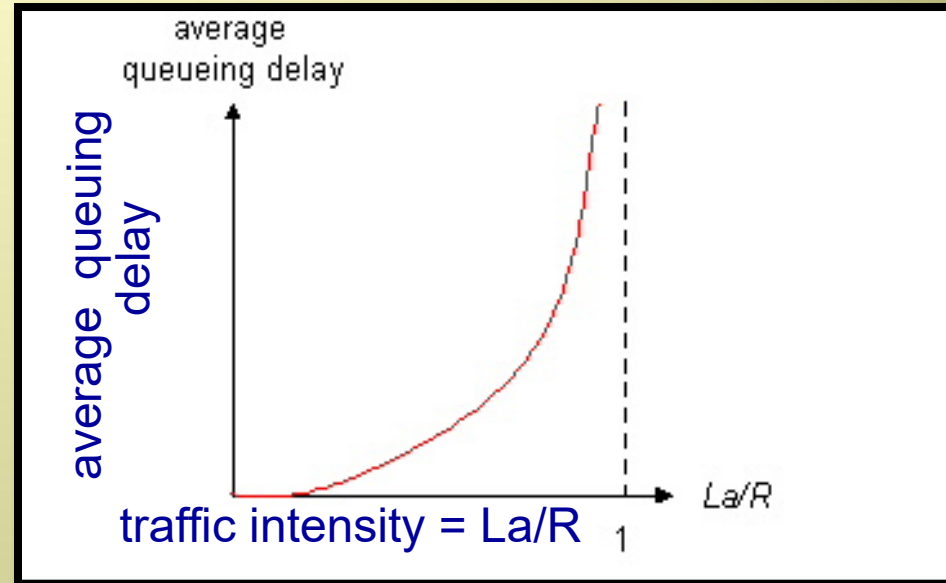

$La/R \sim 0$



$La/R \rightarrow 1$

“Real” Internet end-to-end delays and routes

- ❖ end-to-end delay: total delay between a source and destination
- ❖ provides what do “real” Internet delay & loss look like?
- ❖ `traceroute` program: provides delay measurement from source to router along end-end Internet path towards destination. For all i :
 - sends three packets that will reach router i on path towards destination
 - router i will return packets to sender
 - sender times interval between transmission and reply.

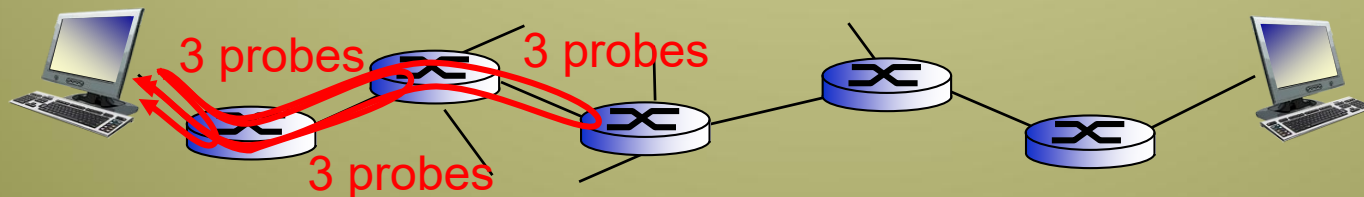

“Real” Internet delays, routes

traceroute: gaia.cs.umass.edu to www.eurecom.fr

3 delay measurements from
gaia.cs.umass.edu to cs-gw.cs.umass.edu



1	cs-gw (128.119.240.254)	1 ms	1 ms	2 ms
2	border1-rt-fa5-1-0.gw.umass.edu (128.119.3.145)	1 ms	1 ms	2 ms
3	cht-vbns.gw.umass.edu (128.119.3.130)	6 ms	5 ms	5 ms
4	jn1-at1-0-0-19.wor.vbns.net (204.147.132.129)	16 ms	11 ms	13 ms
5	jn1-so7-0-0-0.wae.vbns.net (204.147.136.136)	21 ms	18 ms	18 ms
6	abilene-vbns.abilene.ucaid.edu (198.32.11.9)	22 ms	18 ms	22 ms
7	nycm-wash.abilene.ucaid.edu (198.32.8.46)	22 ms	22 ms	22 ms
8	62.40.103.253 (62.40.103.253)	104 ms	109 ms	106 ms
9	de2-1.de1.de.geant.net (62.40.96.129)	109 ms	102 ms	104 ms
10	de.fr1.fr.geant.net (62.40.96.50)	113 ms	121 ms	114 ms
11	renater-gw.fr1.fr.geant.net (62.40.103.54)	112 ms	114 ms	112 ms
12	nio-n2.cssi.renater.fr (193.51.206.13)	111 ms	114 ms	116 ms
13	nice.cssi.renater.fr (195.220.98.102)	123 ms	125 ms	124 ms
14	r3t2-nice.cssi.renater.fr (195.220.98.110)	126 ms	126 ms	124 ms
15	eurecom-valbonne.r3t2.ft.net (193.48.50.54)	135 ms	128 ms	133 ms
16	194.214.211.25 (194.214.211.25)	126 ms	128 ms	126 ms
17	* * *			
18	* * *			
19	fantasia.eurecom.fr (193.55.113.142)	132 ms	128 ms	136 ms

trans-oceanic link

* means no response (probe lost, router not replying)



* Do some traceroutes from exotic countries at www.traceroute.org

Packet loss

- ❖ queue (buffer) preceding link in buffer has finite capacity
- ❖ packet arriving to full queue dropped (lost)
- ❖ lost packet may be retransmitted by previous node, by source end system, or not at all

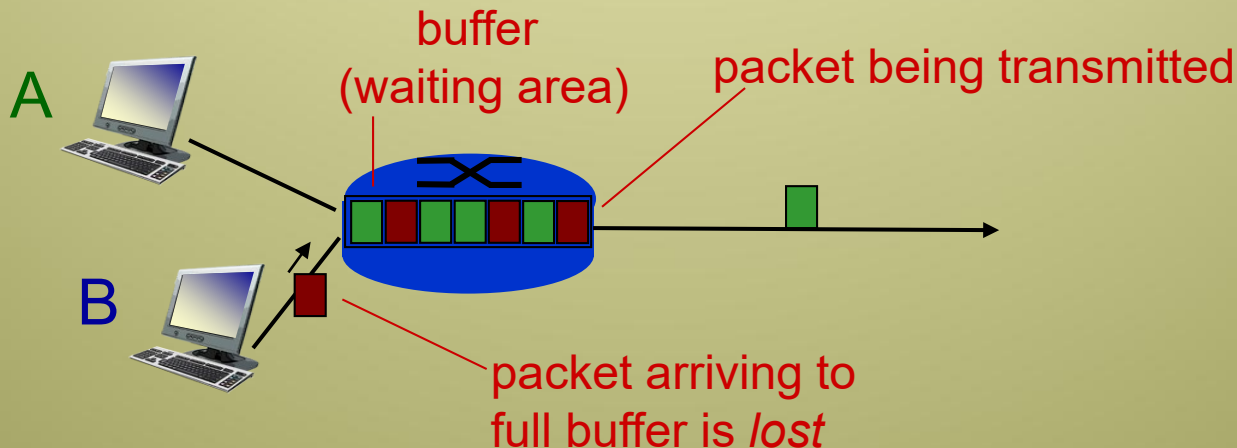

Throughput

- ❖ *throughput*: rate (bits/time unit) at which bits transferred between sender/receiver
 - *instantaneous*: rate at given point in time
 - *average*: rate over longer period of time

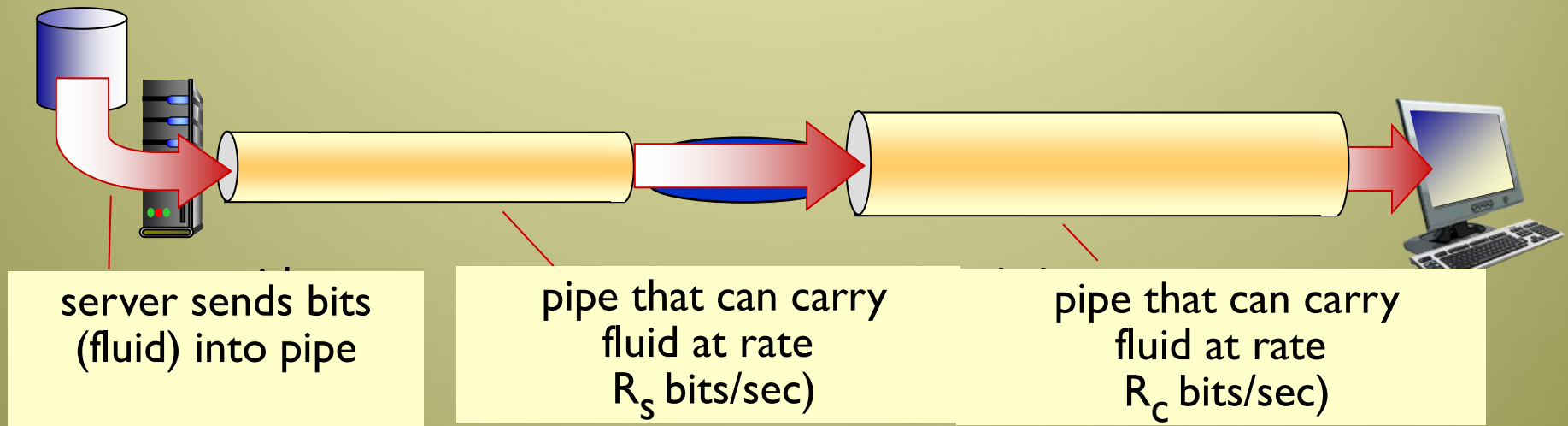

Throughput (more)

❖ $R_s < R_c$ What is average end-end throughput?

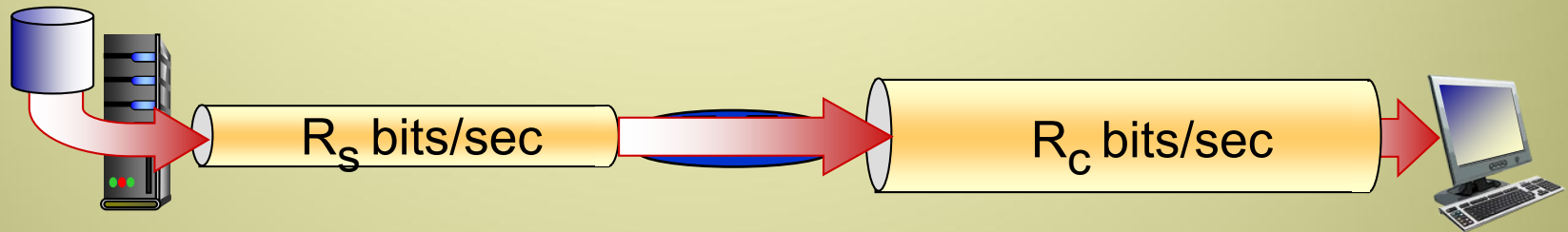

❖ $R_s > R_c$ What is average end-end throughput?

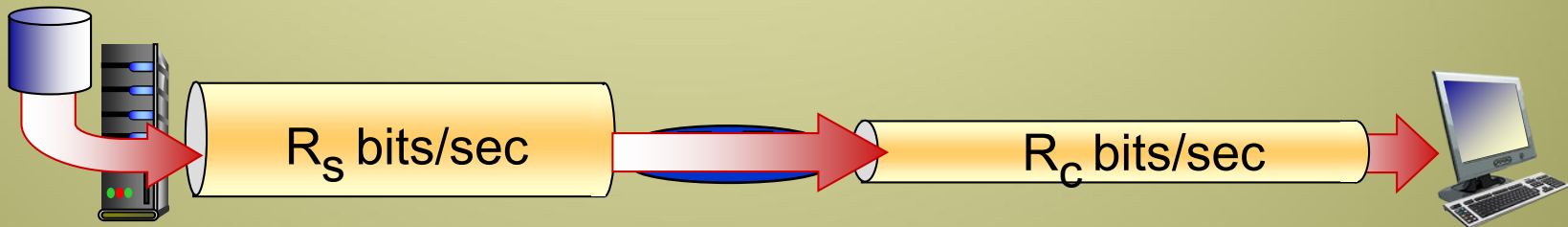

bottleneck link

link on end-end path that constrains end-end throughput

Throughput (more)

- ❖ Example: what is the needed **time** to send a music file of size 32Mbit over the following network if $R_s = 2\text{Mbps}$ and $R_c = 4\text{Mbps}$?

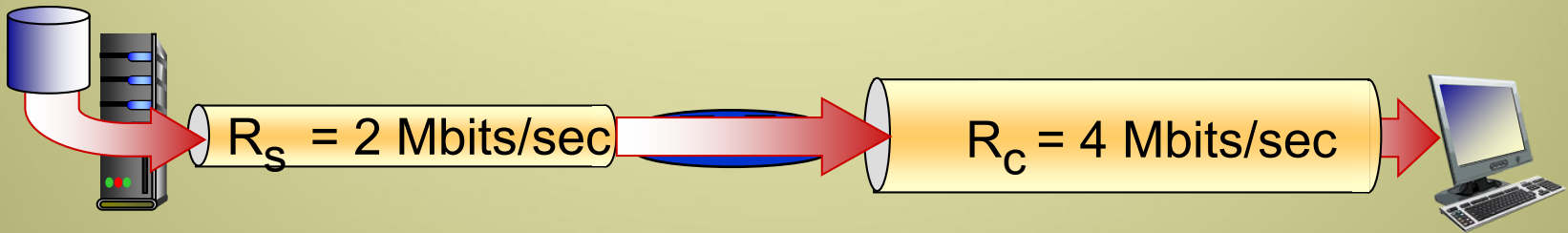

- ❖ Time needed = $32\text{M}/2\text{Mbps} = 16$ seconds

Throughput: Internet scenario

- ❖ Assume 10 servers and 10 clients are connected to the core of the network
- ❖ per-connection end-end throughput: $\min(R_c, R_s, R/10)$
- ❖ in practice: R_c or R_s is often bottleneck

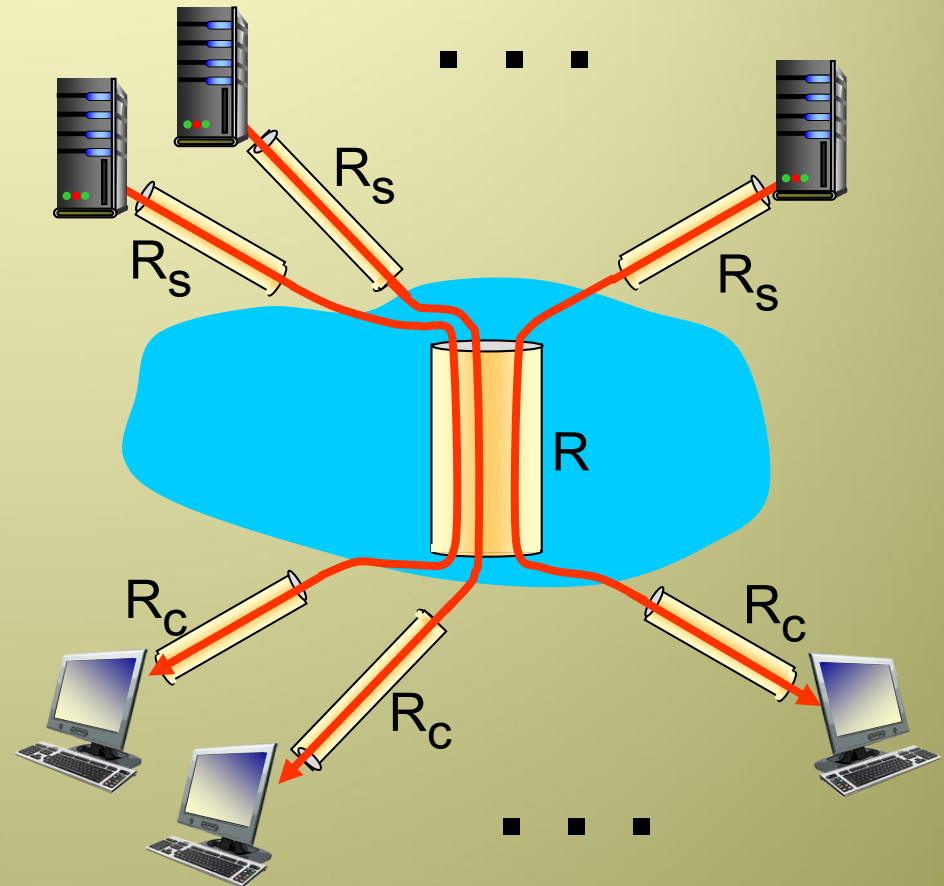

10 connections (fairly) share backbone bottleneck link R bits/sec

Protocol “layers” – The ISO OSI Vision

*Networks are complex,
with many “pieces”:*

- hosts
- routers
- links of various media
- applications
- protocols
- hardware, software

Question:

is there any hope of
organizing structure of
network?

.... or at least our
discussion of networks?

Open Systems & The OSI Model

- ❖ *Open system*: A set of protocols that would allow any two different systems to communicate regardless of their underlying architecture
- ❖ The **Open System Interconnect (OSI)** Model:
 - Introduced by ISO
 - Employs 7 layers, where each layer performs specific functions and communicate with the one above and below it (**service model**)
 - Higher layers deal more with the user applications, services and activities
 - Lower layers deal more with the actual transmission of information
 - Advantages of layered model?

Organization of air travel

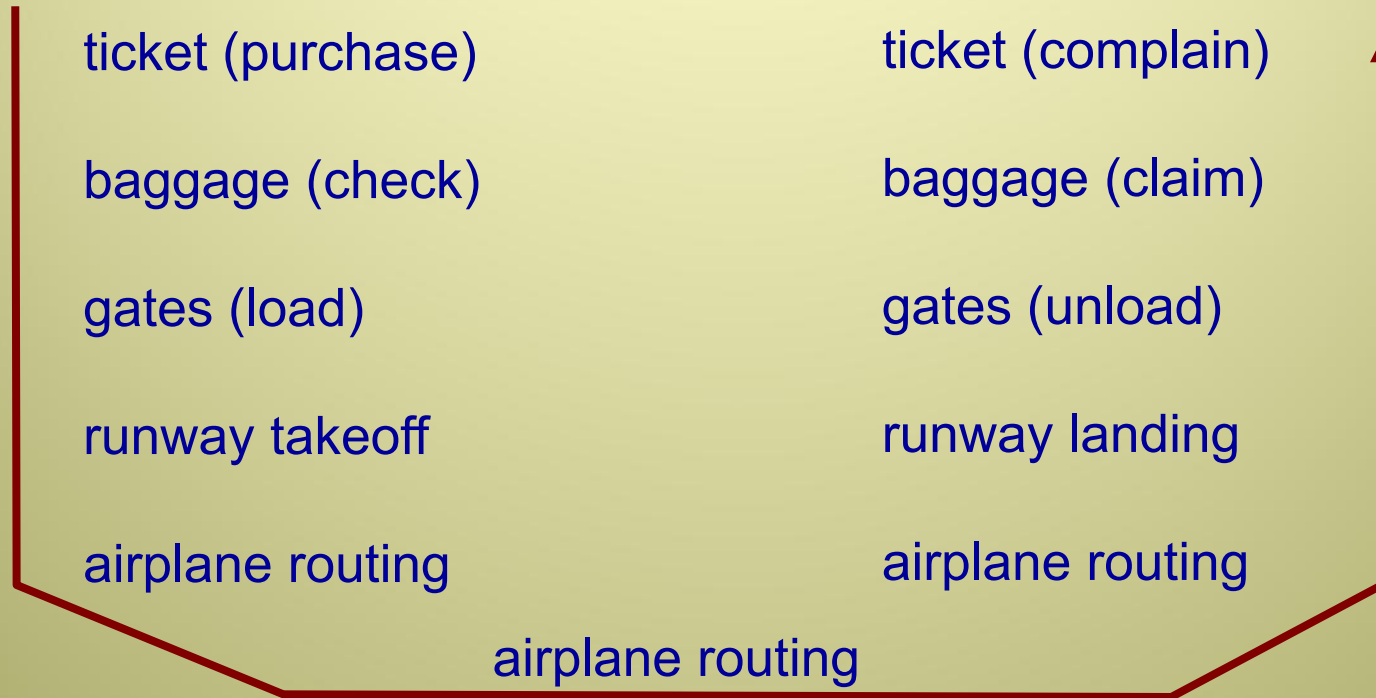

❖ a series of steps

Layering of airline functionality

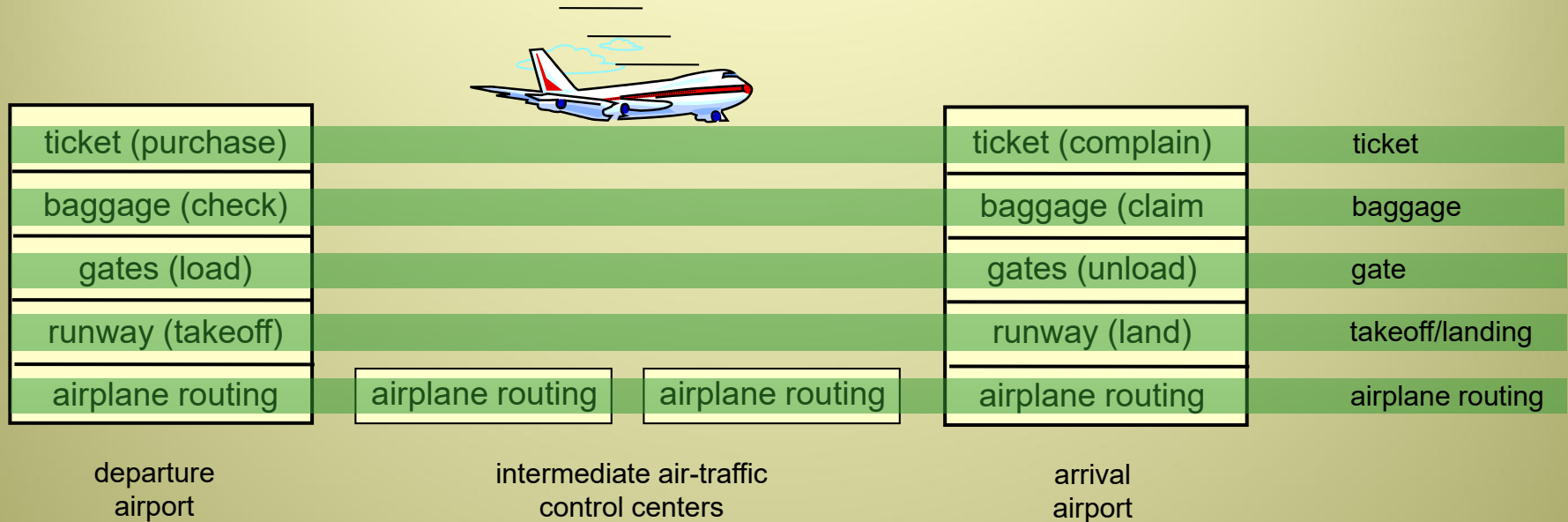

layers: each layer implements a service

- via its own internal-layer actions
- relying on services provided by layer below

Why layering?

dealing with complex systems:

- ❖ explicit structure allows identification, relationship of complex system's pieces
 - layered *reference model* for discussion
- ❖ modularization eases maintenance, updating of system
 - change of implementation of layer's service transparent to rest of system
 - e.g., change in gate procedure doesn't affect rest of system
- ❖ layering considered harmful?

ISO/OSI reference model

- ❖ *application*: supporting network applications
 - FTP, SMTP, HTTP, DNS
- ❖ *presentation*: allow applications to interpret meaning of data, e.g., encryption, compression, machine-specific conventions
- ❖ *session*: synchronization, checkpointing, recovery of data exchange
- ❖ *transport*: process-process data transfer (**segments**)
 - TCP, UDP
- ❖ *network*: routing of **datagrams** from source to destination
 - IP, routing protocols, billings
- ❖ *link*: data transfer between neighboring network elements (**frames**)
 - Ethernet, 802.111 (WiFi), PPP
- ❖ *physical*: bits “on the wire” - copper, TP, Fiber, etc.

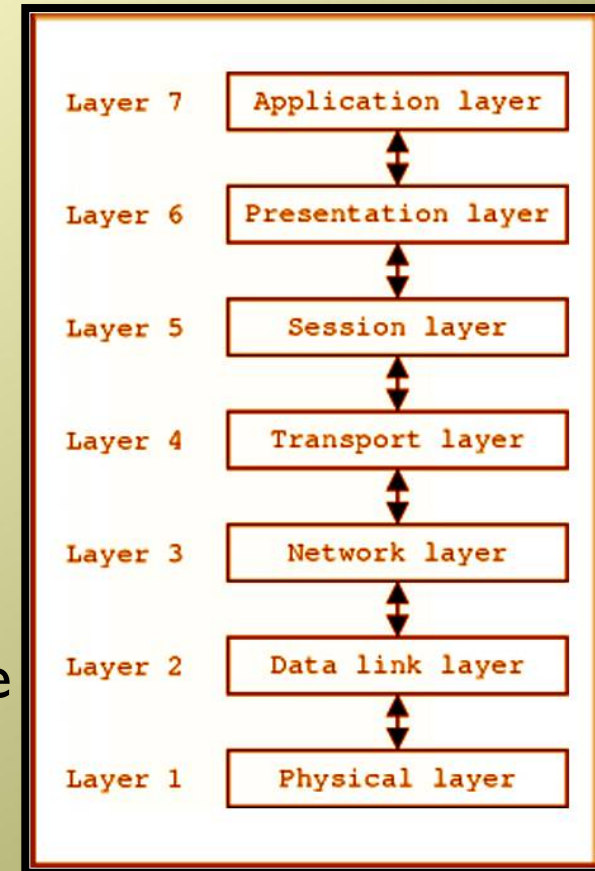

ISO/OSI model

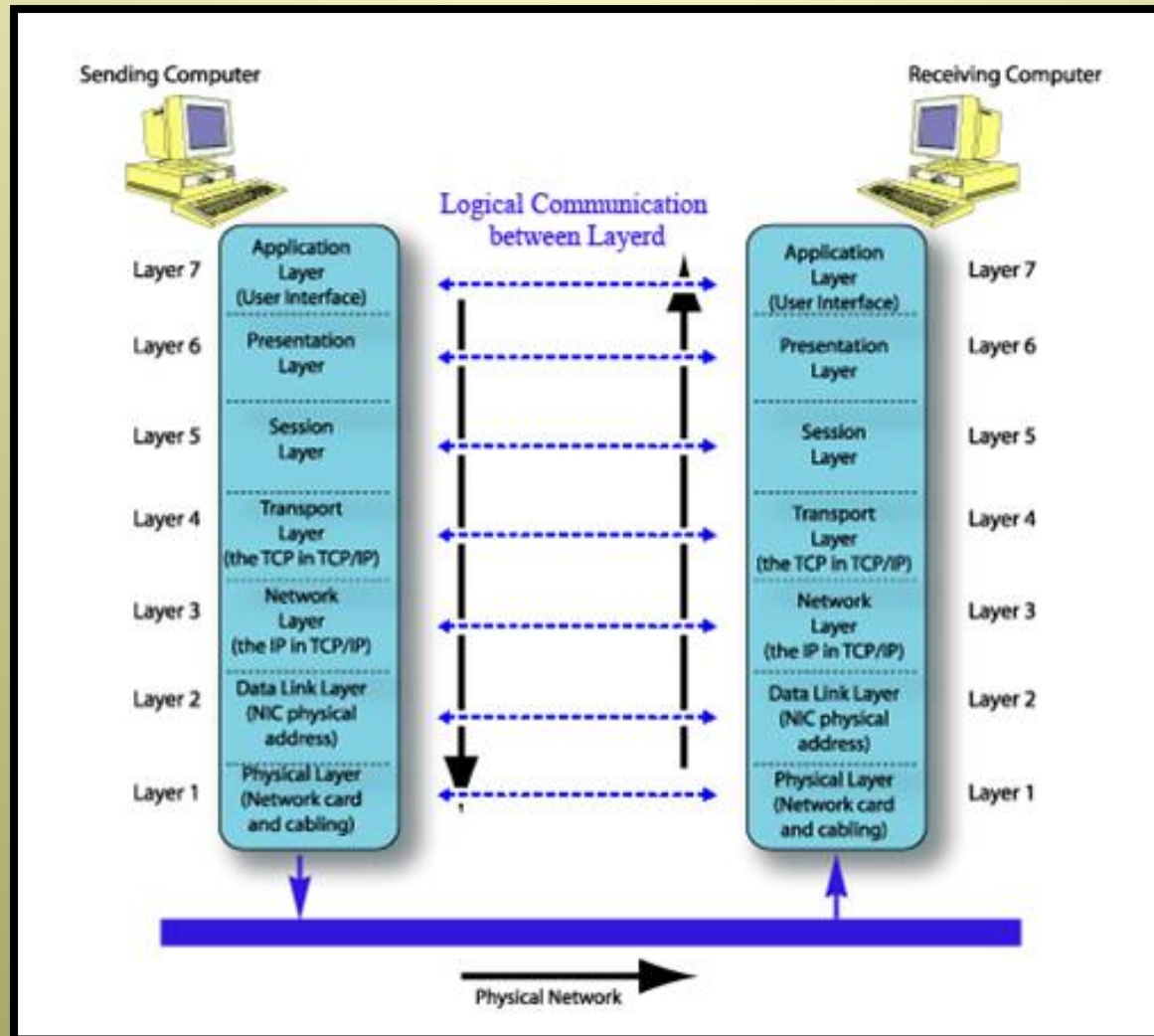

Internet protocol stack

- The Internet has a similar, not identical layers to the ones of the OSI
- The lower 4 layers roughly correspond to the lower 4 layers of OSI
- Functionality of the highest 3 layers of OSI are either omitted, or incorporated in the 5th layer of the Internet
- Layer 4: TCP or UDP
- Layer 5: HTTP, FTP, ..etc

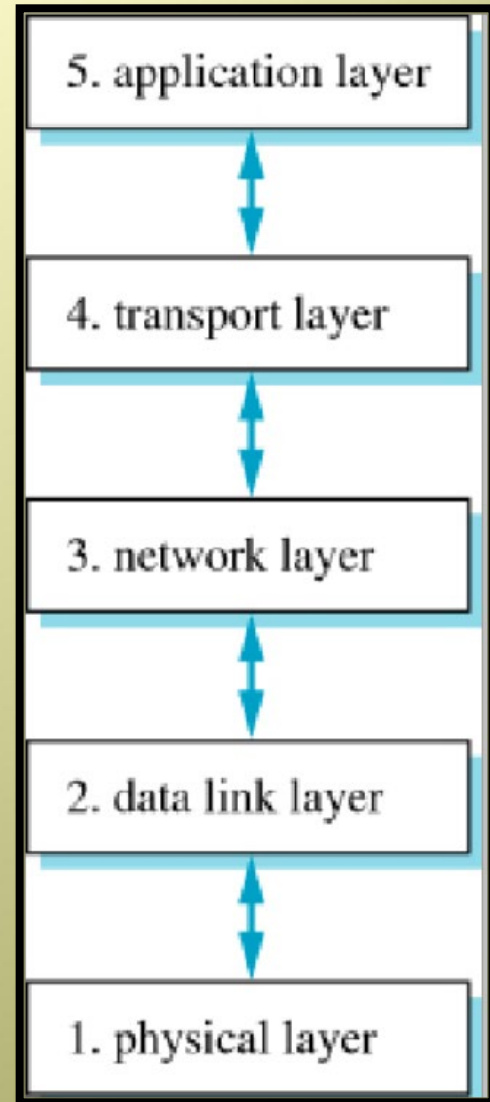

Encapsulation

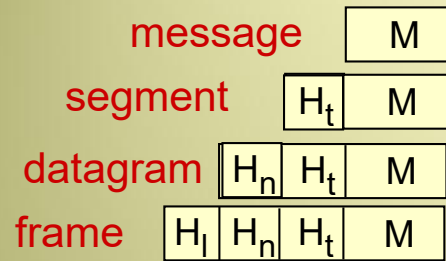

source

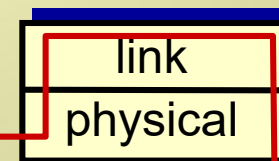
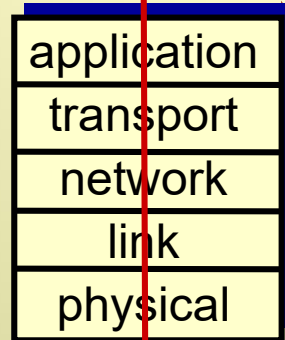

switch

destination

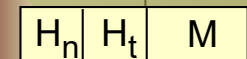
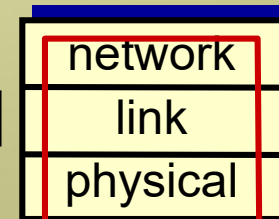
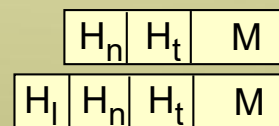
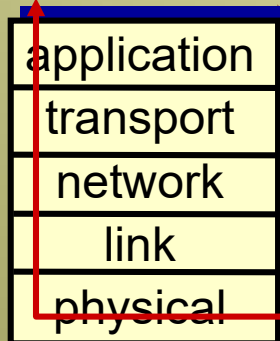
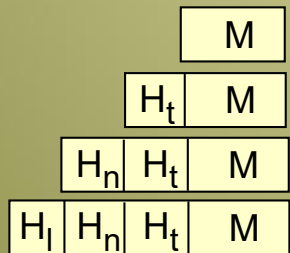

router

Network security

- ❖ A central topic in the field of computer networking today
- ❖ **field of network security:**
 - how bad guys can attack computer networks
 - how we can defend networks against attacks
 - how to design architectures that are immune to attacks
- ❖ **Internet not originally designed with (much) security in mind**
 - *original vision:* “a group of mutually trusting users attached to a transparent network” 😊
 - Internet protocol designers playing “catch-up”
 - security considerations in all layers!

Bad guys: put malware into hosts via Internet

- ❖ malware can get in host from:
 - *virus*: self-replicating infection by receiving/executing object (e.g., e-mail attachment)
 - *worm*: self-replicating infection by passively receiving object that gets itself executed (i.e. by running a vulnerable network application to which an attacker can send malware without user interventions)
- ❖ **spyware malware** can record keystrokes, web sites visited, upload info to collection site
- ❖ infected host can be enrolled in **botnet**, used for spam. DDoS attacks

Bad guys: attack server, network infrastructure

Denial of Service (DoS): attackers make resources (server, bandwidth) unavailable to legitimate traffic by overwhelming resource with bogus traffic

1. select target
2. break into hosts around the network (see botnet)
3. send packets to target from compromised hosts

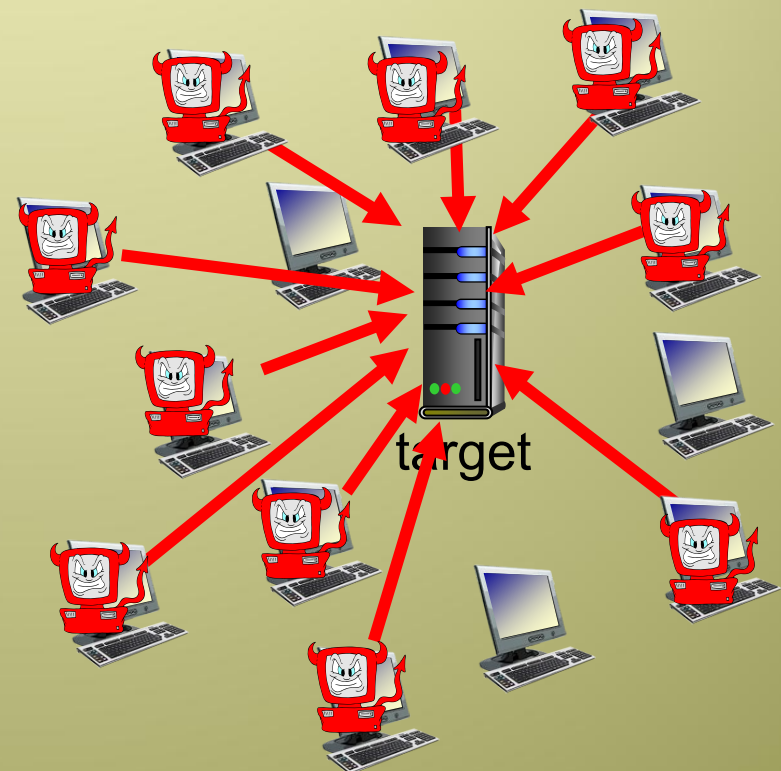

Bad guys: attack server, network infrastructure

Most DoS attacks fall in one of three categories:

- ❖ *Vulnerability attack*: sending well-crafted messages to the vulnerable application resulting in it being stopped or crashed
- ❖ *Bandwidth flooding*: send too many packets that the access link to the server becomes clogged, preventing other packets from reaching the server
- ❖ *Connection flooding*: establish many open TCP connections that the server stops accepting any further connections

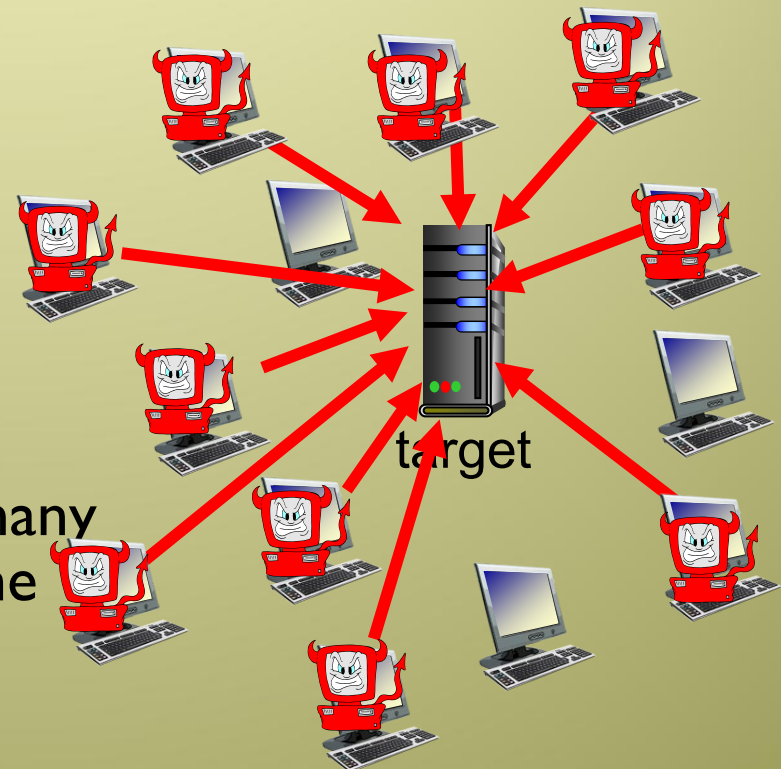

Bad guys can sniff packets

packet “sniffing”:

- broadcast media (shared ethernet, wireless)
- promiscuous network interface reads/records all packets (e.g., including passwords!) passing by

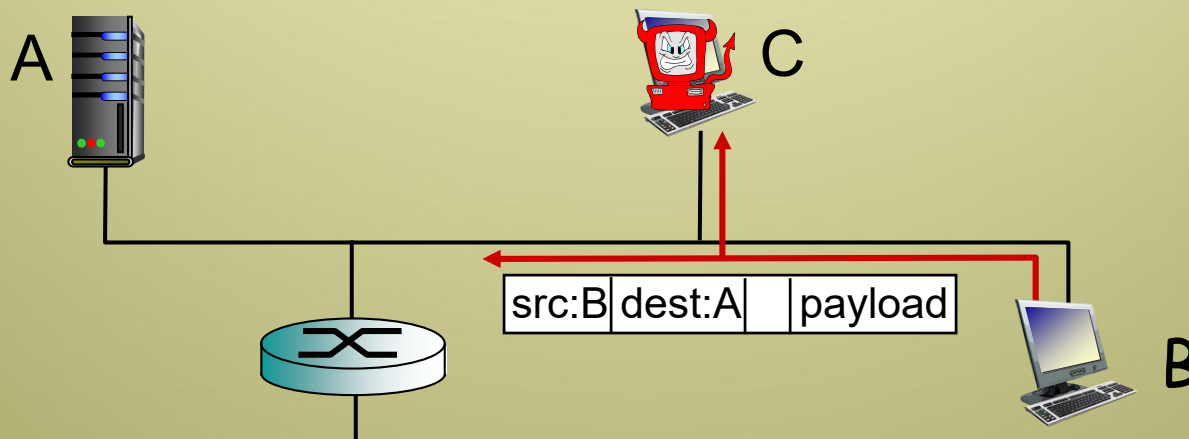

Bad guys can use fake addresses

IP spoofing: send packet with false source address, hence fooling the receiver as if the message was from a trusted sender

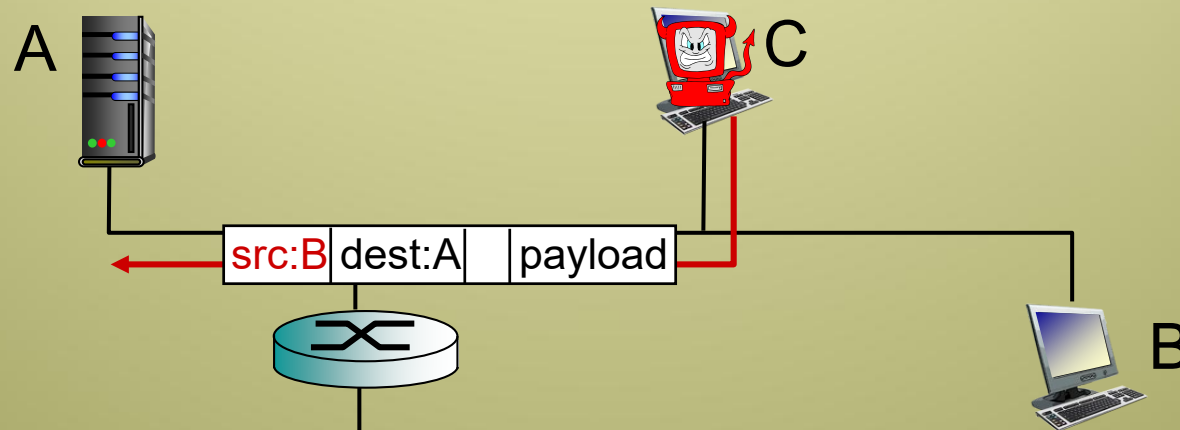

... lots more on security to come