

Question 1.....(17 points)

RMS Value and Power

(a) For the periodic waveform in Figure 1 answer the following:

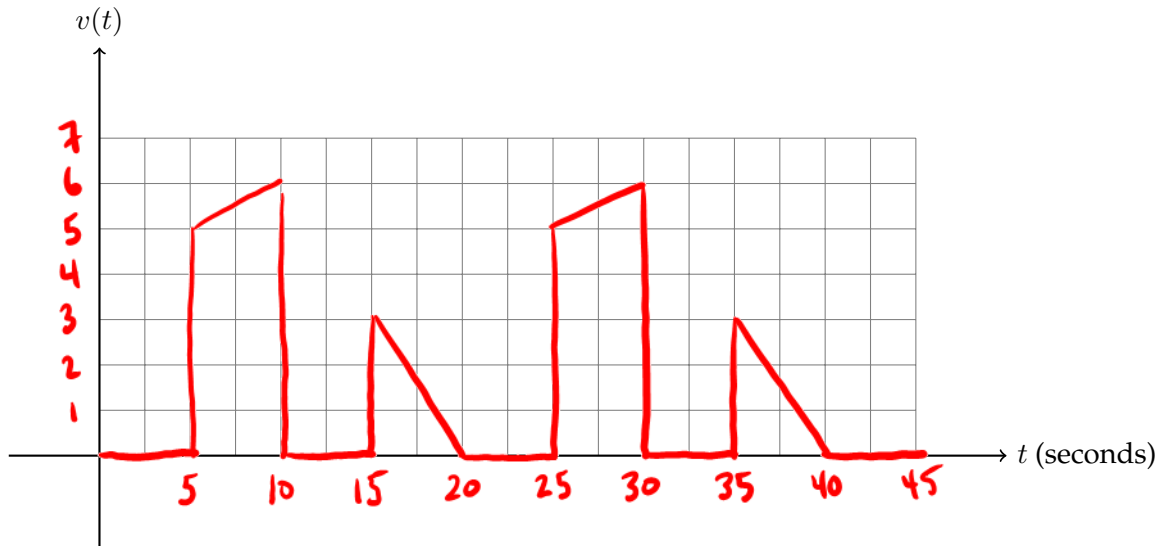

Figure 1: A periodic waveform.

a.i) For one representative period, what are the equations for the non-zero parts of the waveform?

Answer: $v(t) =$ _____

/3

a.ii) Using the equations above, what is the equation for calculating the RMS value of the waveform?

Answer: RMS= _____

/3

a.iii) What is the RMS value of the waveform?

Answer: RMS= _____

/2

(b) In the circuit of Figure 2, find the power (absorbed or supplied) in each of the **3** elements.

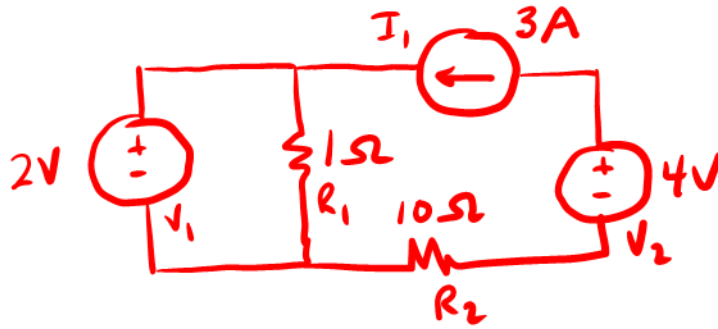

Figure 2: Circuit for power analysis.

Answer: Power in I_1 (in watts): _____

Power in V_2 (in watts): _____

Power in V_1 (in watts): _____

/4

(c) Given the circuit of Figure 3,

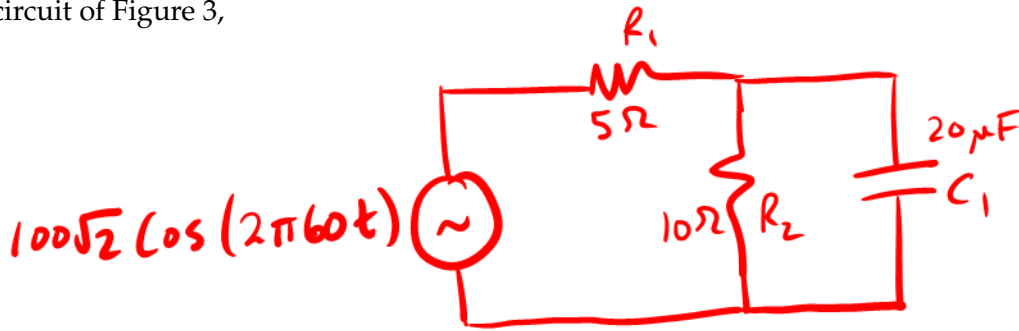

Figure 3: Circuit for power analysis.

c.i) What is the ^{average} power dissipated in R_1 ?

Answer: Power in (in watts): _____

/3

c.ii) What is the ^{average} power dissipated in C_1 ?

Answer: Power in (in watts): _____

/2

Question 2.....(19 points)

Thévenin, Norton, and Superposition

(a) For the circuit shown below find the Thévenin equivalent source between the terminals A and B. /7

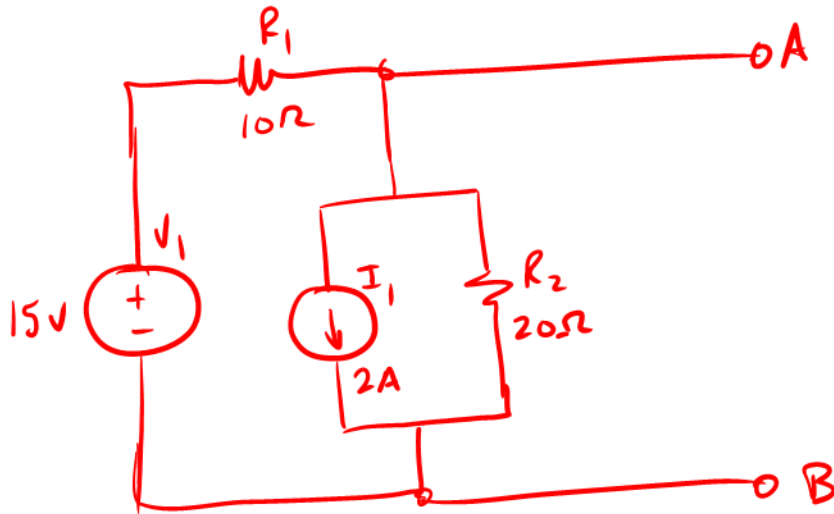

(b) For the circuit shown in below find the Norton equivalent source between the terminals A and B. /7

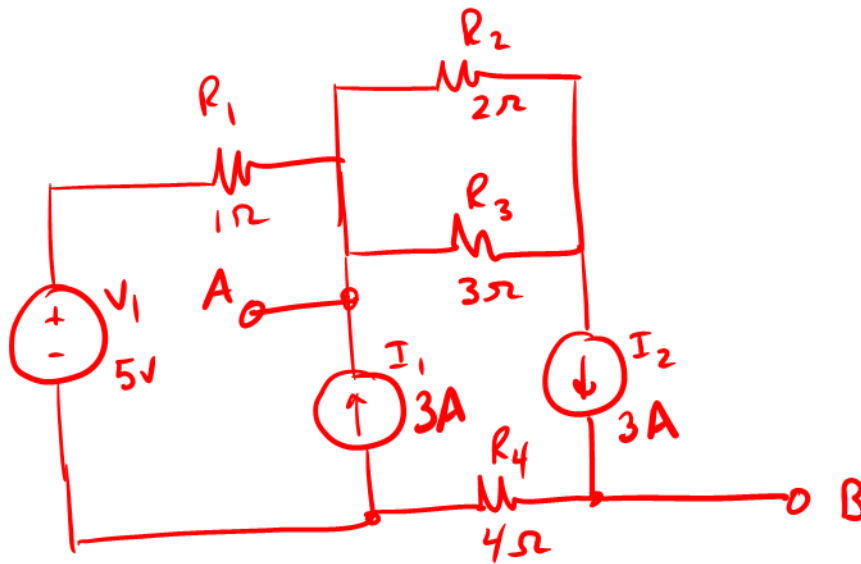

(c) Given the circuit of Figure 4, use superposition to find the contribution of each source toward V_{ab} and from that find the total V_{ab} .

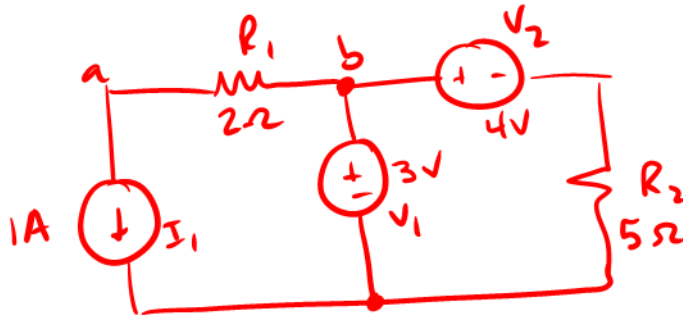

Figure 4: Circuit for superposition analysis.

c.i) Answer: Contribution of I_1 to V_{ab} : _____ /2

c.ii) Answer: Contribution of V_2 to V_{ab} : _____ /2

c.iii) Answer: Total V_{ab} using superposition: _____ /1

Question 3.....(12 points)

Nodal Analysis and Loop Analysis

(a) Given the circuit of Figure 5, write the nodal equations for nodes ① and ② using the convention that currents entering a node are considered positive. There is no need to simplify your equations.

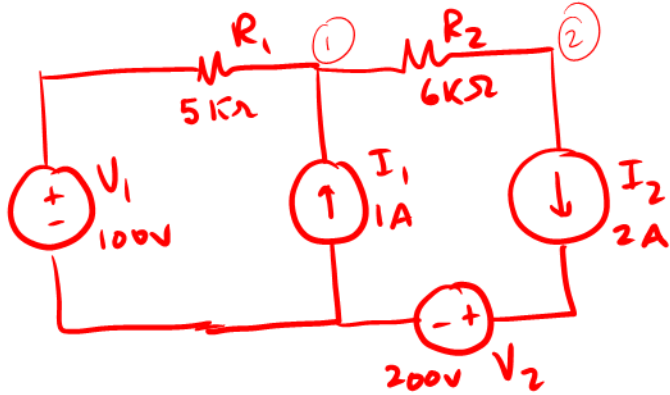

Figure 5: Circuit for Nodal analysis.

a.i) Answer: nodal equation: _____ /2

a.ii) Answer: nodal equation: _____ /2

a.iii) Answer: nodal equation: _____ /2

(b) Given the circuit of Figure 6, write the loop equations for loops 1 and 2. There is no need to simplify your equations.

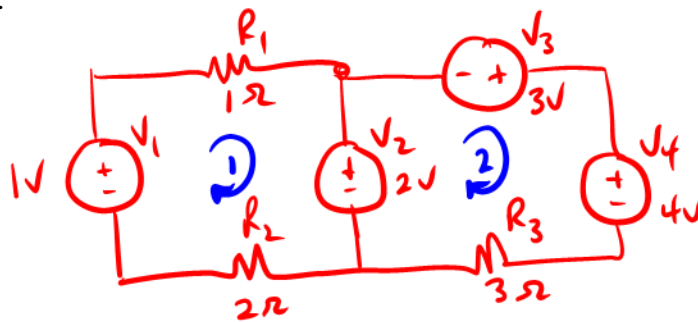

Figure 6: Circuit for Loop analysis.

b.i) Answer: Loop equation for 1: _____ /3

b.ii) Answer: Loop equation for 2: _____ /3

Question 4.....(18 points)

Phasor Analysis

Note: Answers may be in either polar form (e.g. $10\angle 45^\circ$ volts) or Cartesian form (e.g. $100 - j50$ ohms), but they must still be simplified.

(a) Given the circuit of Figure 7,

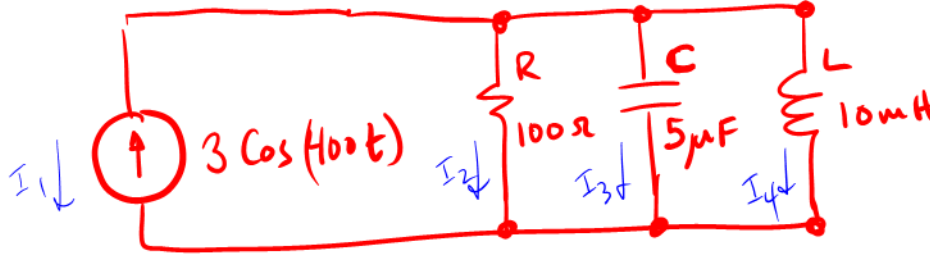

Figure 7: Circuit for phasor analysis.

a.i) Find the impedance of *C and L*

Answer: Z_C : _____ /2

Z_L : _____ /1

a.ii) Find all of the indicated *currents*, as phasors.

Answer: I_1 : _____ /1

I_2 : _____ /1

I_3 : _____ /2

I_4 : _____ /2

- (b) Given the KVL equation $V_3 = V_1 - V_2$ in which $V_1 = 10 \angle 60^\circ$ and $V_2 = 15 \angle -45^\circ$:
 b.i) Calculate V_3 as a phasor.

Answer: _____

/2

- b.ii) For $V_3 = V_1 - V_2$, show that KVL is satisfied using a clear phasor diagram, drawn approximately to scale:

Answer: Phasor diagram showing KVL:

- (c) A *series resonant RLC* circuit is to have a resonant frequency of 10 MHz and is to use $C = 10 \mu\text{F}$.
 c.i) What value of L is required?

/3

Answer: _____

/2

- c.ii) If the *series resonant RLC* is operated at resonance, and the circuit's $Q = 5$, and the *voltage on the inductor is $V_L = j 30 \text{ V}$* , what must be the *voltage on the capacitor?*

Answer: _____

/2

Question 5.....(11 points)

Bode Plot Questions

$$H(j\omega) = \frac{180000}{1000 + j\omega 200}$$

Given the transfer function, answer the following:

- (a) What is the *corner frequency in Hz?* ?

Answer: _____

/2

- (b) Draw the magnitude and phase Bode plots below. For the magnitude plot, include both the straight line (asymptotic) approximate plot as well as a sketch of the actual curve. For the magnitude plot, indicate the value of any slope(s). Label the x-axis and y-axis units, and add numbers to the x-axis and y-axis grid lines as appropriate for the magnitude and phase plots. Label all important frequencies, magnitudes, and angles. For the magnitude plot, indicate the value of the difference between the straight line approximate plot and the actual curve at the corner frequency.

b.i) Magnitude Bode plot:

/5

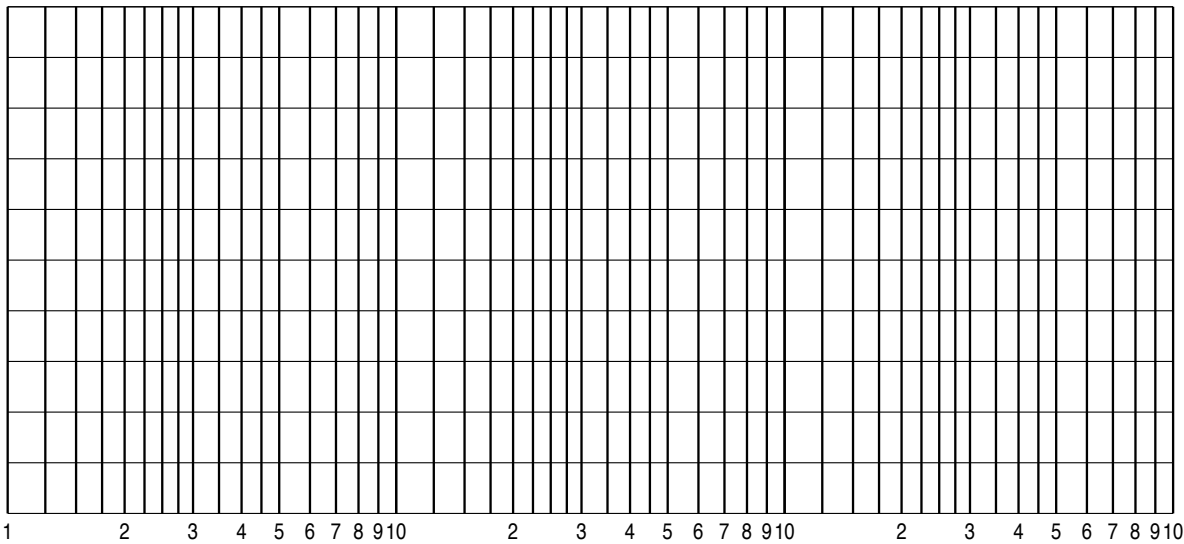

b.ii) Phase Bode plot:

/4

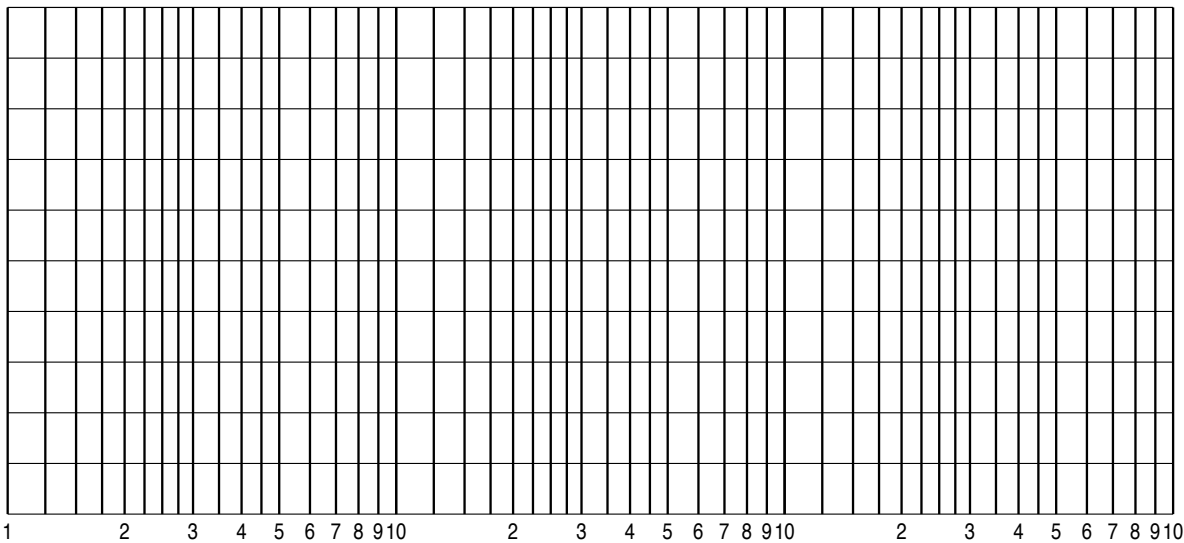

Question 6.....(22 points)

Transient Analysis Questions

(a) In the circuit shown in Figure 8, switch SW1 has been *closed* for all of time $t < 0$. At time $t = 0$ switch SW1 *opens*

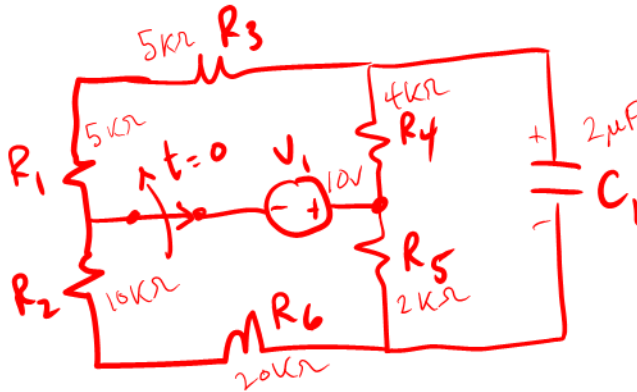

Figure 8: Circuit for transient analysis.

a.i) What is the *voltage across the capacitor* for $t < 0$?

Answer: For $t < 0$, $V_C =$ _____

/1

a.ii) Derive an expression for the *voltage across the capacitor* for $t > 0$ ms.

Answer: For $t > 0$, $V_C(t) =$ _____

/8

a.iii) Sketch $V_C(t)$ over the time interval -30ms to 50ms . Clearly show the time constant and its relationship to the waveform.

/3

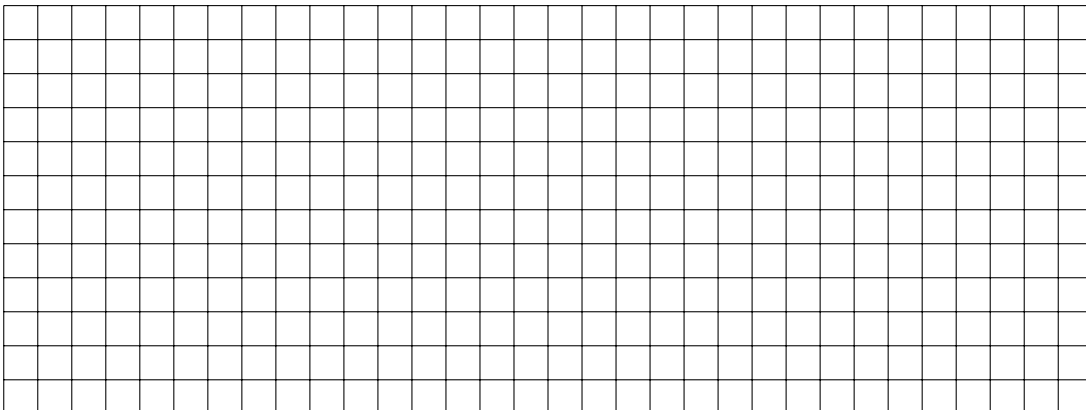

Figure 9: Plot of _____.

a.iv) Suppose the response above is interrupted by switch SW1 *closing* again at time $t = 30\text{ms}$. Derive the resulting expression for $V_C(t)$.

Answer: _____

/5

(b) In the circuit shown in Figure 10, switch SW1 has been *open* for all of time $t < 0$. At $t = 0$ switch SW1 *closes*.

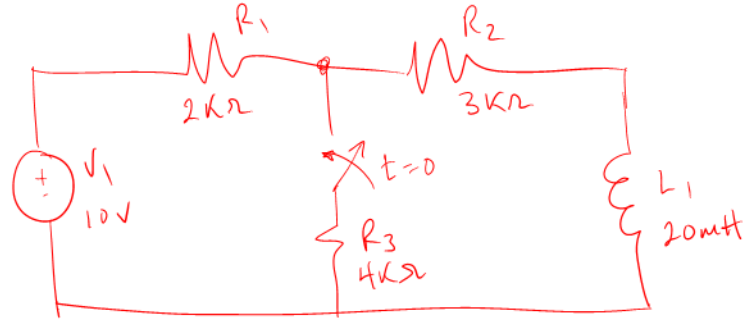

Figure 10: Circuit for transient analysis.

b.i) What is the *inductor current just before the switch closes?*

Answer: : _____

/1

b.ii) What is *inductor current for $t > 0$*

Answer: : _____

/3

b.iii) What is the time constant of the circuit, taking *v_{R2} as the output voltage?*

Answer: Time constant: _____

/1

HAPPY HOLIDAYS