

Student Name: \_\_\_\_\_

**Chemistry 2213 Intersession 2014  
MIDTERM TEST**

Thursday, May 22, 2014  
9:30 a.m. – 12:00 p.m.

**EXAM CODE 000**

Please note:

- This test consists of **35** multiple-choice questions of equal weight on 30 total pages including pages marked as scrap paper and the last page with a periodic table. **IT IS YOUR RESPONSIBILITY TO ENSURE THAT YOU HAVE A COMPLETE EXAMINATION PAPER!**
- Record your name on the front of this test.
- Place your student ID on your desk.
- Fill out the top of your SCANTRON Sheet IMMEDIATELY! Be sure to include your exam code (111/222), your name (printed and signed) and student number. It is your responsibility to properly fill out your SCANTRON sheet in the time provided. **USE pencil ONLY**
- Calculators and ALL electronic devices (cell phones, PDAs, iPods, MP3 players, Blackberries, etc. may not be used during the exam even for timekeeping purposes. They must be stored in a power off mode, in your bag, at the front of the room.
- There is NO PENALTY for incorrect answers.
- Use of a molecular model set is permitted. Molecular models must be completely disassembled and stored in a clear plastic bag. Sharing of molecular models or model pieces is strictly forbidden. They must remain on your desk.
- **The exam is to be done individually. The instructor and proctors will not interpret, translate, clarify or explain questions. They will not confirm, verify or assist you with answers or thinking.**
- **There is no EXTRA time allotted for filling in the Scantron sheet. At the end of time (12:00 p.m.), everyone remaining must put down their writing instruments, close the exam booklet and remain seated**
- **If you do not leave before 11:45 A.M. you must remain in your seat until you are dismissed. No talking is permitted at any time.**

You must hand in BOTH the Exam paper and the SCANTRON Sheet.  
***Relax, think and have fun testing your knowledge!***

1. The molecule below is *wyerone*, which is obtained from fava beans (*Vicia faba*) and has been found to possess antifungal properties. Which of A-E indicate the correct number of  $\pi$ -bonds and  $sp^2$  hybridized carbon atoms in this molecule?

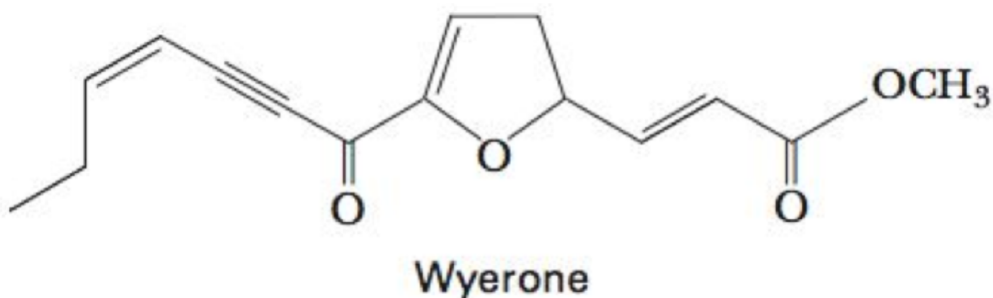

	$\pi$ -bonds	$sp^2$ hybridized carbon atoms
[A]	6	10
[B]	6	9
[C]	5	10
[D]	7	8
[E]	5	8

2. Shown below are correctly drawn structures for a reaction done in the Workentin research lab. What are the formal charges on atoms X, Y and Z represent?

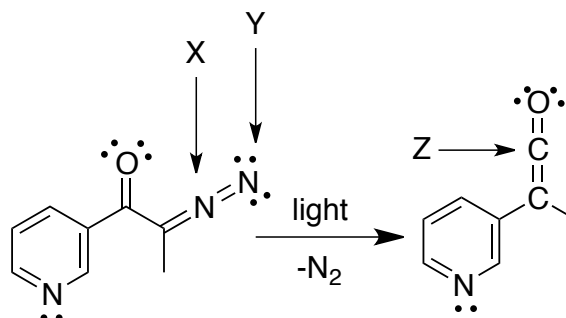

	X	Y	Z
[A]	-1	0	-1
[B]	0	-1	+1
[C]	+1	-1	0
[D]	-1	+1	+1
[E]	+1	0	0

3. Approximately 66 million kgs of vitamin C are made in North America every year. Below is the structure of Vitamin C (ascorbic acid). Which of the indicated protons shown (i-v) is the most acidic?

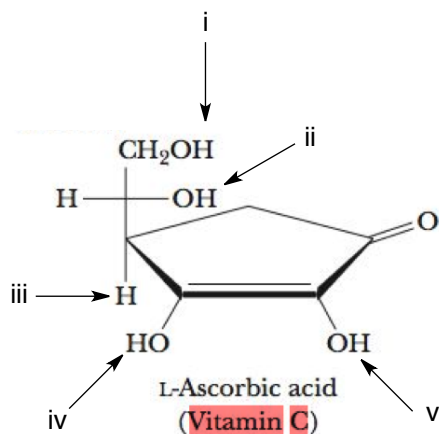

[A]	iv
[B]	iii
[C]	i
[D]	ii
[E]	v

4. Which of A-E properly lists the molecules in order from most basic to least basic?

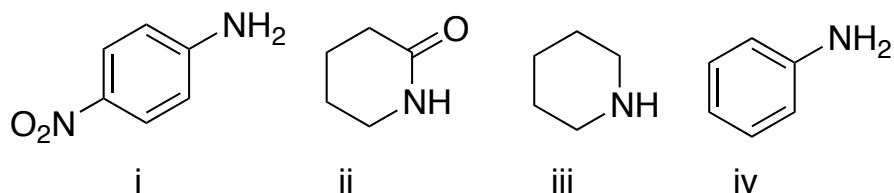

	Most basic → Least Basic
[A]	iii > iv > ii > i
[B]	ii > iii > iv > i
[C]	i > ii > iii > iv
[D]	iv > iii > i > ii
[E]	iii > iv > i > ii

5. For each molecule a proton is indicated with an arrow. For which of A-E is the proton with the lowest pKa not indicated properly?

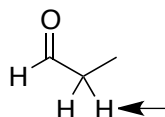
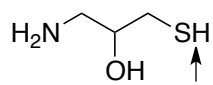
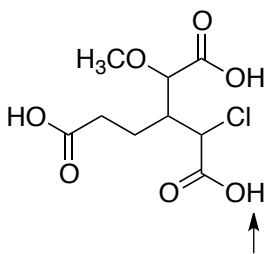
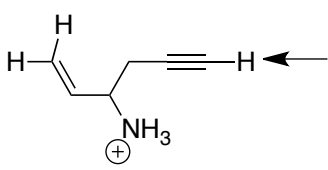
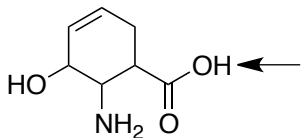
[A]	
[B]	
[C]	
[D]	
[E]	

6. Which statement below is correct for the reaction shown?

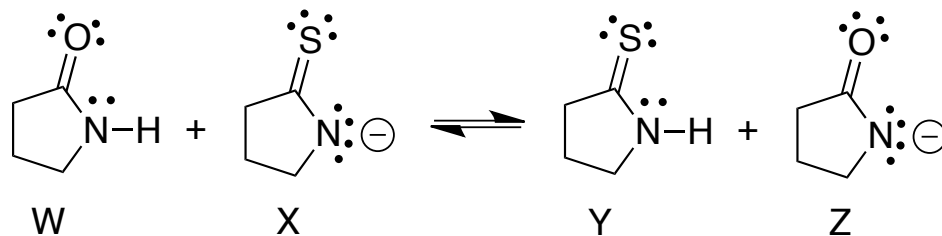

[A]	The equilibrium lies to the left hand side.
[B]	The equilibrium lies to the right hand side.
[C]	Compound X is the best base.
[D]	Compound Y has a higher pKa than compound W.
[E]	The equilibrium favours the production of the stronger acid.

7. Pyrethrum is a natural insecticide obtained from the powdered flower heads of several species of *Chrysanthemum*, particularly *C. cinerariaefolium*. The active substances in pyrethrum, principally pyrethrin I is a contact poison for insects and cold-blooded vertebrates. How many **total** stereoisomers are possible for pyrethrin I, shown below?

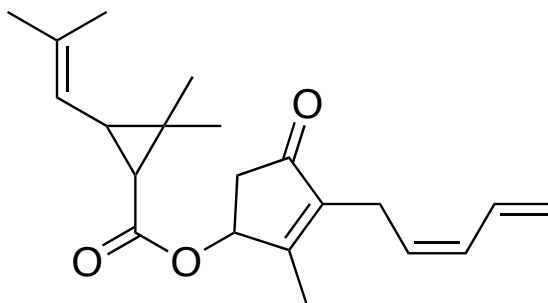

[A]	$2^2$	[B]	$2^4$	[C]	$2^3$	[D]	$2^6$	[E]	$2^5$
-----	-------	-----	-------	-----	-------	-----	-------	-----	-------

8. What is the IUPAC name for each of the following? Just kidding! Which of the following A-E represent a pair of compounds that are **constitutional** isomers of each other?

[A]	
[B]	
[C]	
[D]	
[E]	

9. In which of A-E is the charge **not** stabilized by resonance?

[A]	
[B]	
[C]	
[D]	
[E]	

10. Which of the following is **not** a Newman projection of the molecule shown below?

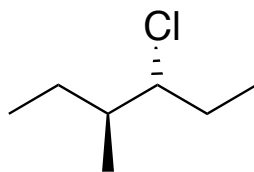

[A]	
[B]	
[C]	
[D]	
[E]	

11. Which of the following A-E shows the lowest energy conformation of the following compound?

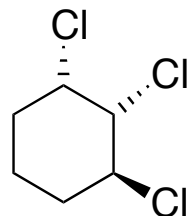

[A]

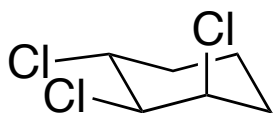

[B]

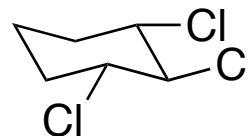

[C]

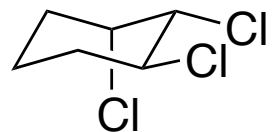

[D]

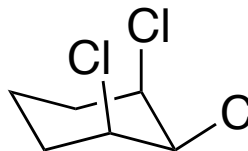

[E]

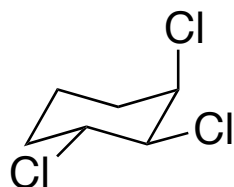

12. Which of A-E correctly identifies the E, Z designation of the three alkenes shown?

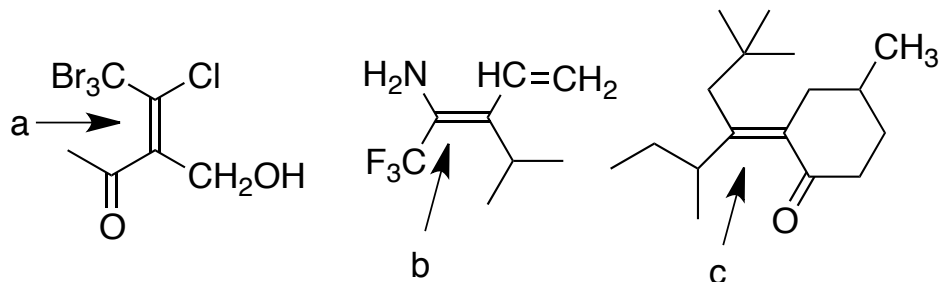

	<b>a</b>	<b>b</b>	<b>c</b>
[A]	Z	E	E
[B]	E	Z	Z
[C]	E	Z	E
[D]	Z	Z	E
[E]	Z	E	neither

13. Which of A-E correctly identifies the R,S designation of the three stereocenters shown in the molecule Kumepaloxane, a signal agent produced by a snail indigenous to Guam (don't slow down now)?

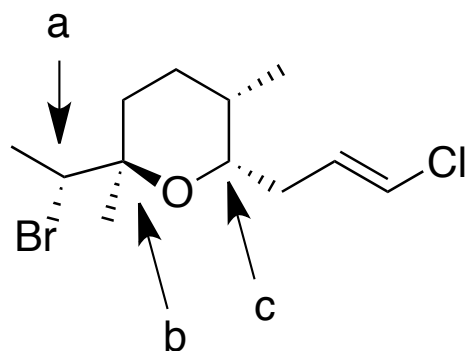

	<b>a</b>	<b>b</b>	<b>c</b>
[A]	S	R	R
[B]	S	R	S
[C]	S	S	R
[D]	R	R	R
[E]	R	R	S

14. For each pair of molecules, which of A-E correctly identifies their relationship to each other? i.e, Pair 1 are \_\_\_\_ and Pair 2 are \_\_\_\_?

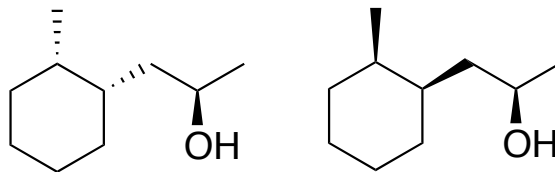

Pair 1

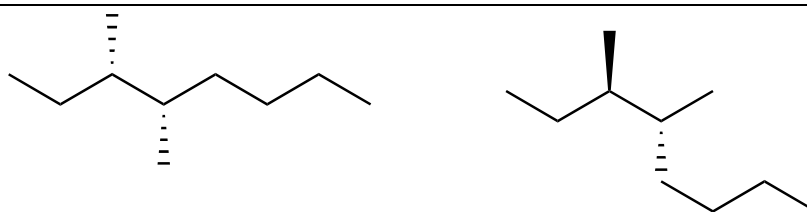

Pair 2

	Pair 1	Pair 2
[A]	Enantiomers	Diastereomers
<b>[B]</b>	Diastereomers	Enantiomers
[C]	meso	Enantiomers
[D]	Conformational Isomers	Diastereomers
[E]	Diastereomers	They are the same

15. Which of A-E correctly identifies which of 1-4 are meso compounds?

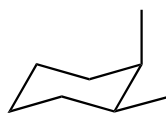

1

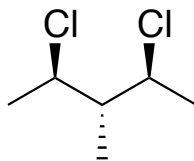

2

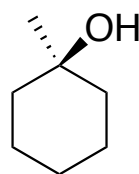

3

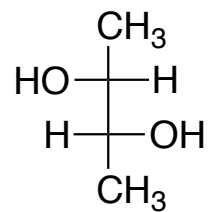

4

[A]	2 and 4
[B]	1, 2, 3 and 4
[C]	1, 2 and 3
<b>[D]</b>	1 and 2
[E]	1, 2 and 3

16. Using any of the reagents listed below, which of A-E shows a reaction that **would not** result in the indicated product as a major product? i.e, Which reaction A-E could you not do using any of the reagents available?

Reagents available:

Br <sub>2</sub>	1. BH <sub>3</sub> 2. H <sub>2</sub> O <sub>2</sub> , NaOH	HBr	OsO <sub>4</sub>	H <sub>2</sub> /Pt
-----------------	---	-----	------------------	--------------------

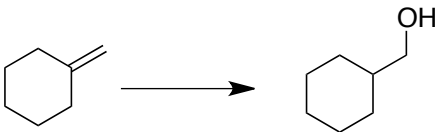
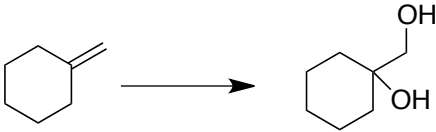
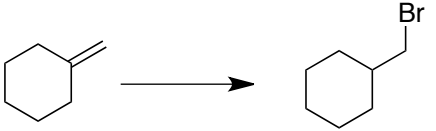
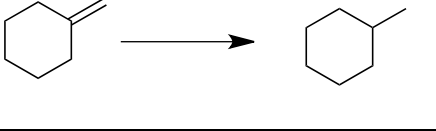
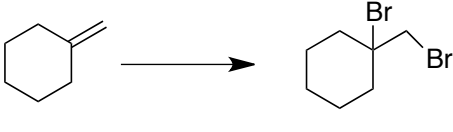
[A]	
[B]	
[C]	
[D]	
[E]	

17. Which of the following reactions will **not** proceed as written to give the product shown as a major product?

[A]	<p>Reaction A: 2-methyl-2-butene reacts with HBr to form 2-bromo-2-methylbutane.</p>
[B]	<p>Reaction B: 2-methyl-2-butene reacts with <math>\text{H}_3\text{O}^+</math> and <math>\text{H}_2\text{O}</math> to form 2-methyl-2-butanol.</p>
[C]	<p>Reaction C: 2-methyl-2-butene reacts with HBr to form 2-bromo-3-methylbutane.</p>
[D]	<p>Reaction D: 2-methyl-2-butene reacts with <math>\text{H}_3\text{O}^+</math> and <math>\text{H}_2\text{O}</math> to form 2-methyl-1-butanol.</p>
[E]	<p>Reaction E: 1-(1-methylcyclohexyl)ethene reacts with HBr to form 1-bromo-1-(1-methylcyclohexyl)ethane.</p>

18. Which of A-E is **not** a major product of the following reaction?

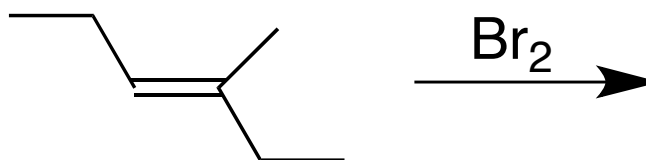

[A]	<p>Structure A: A central carbon-carbon bond. The left carbon has a methyl group (<math>\text{H}_3\text{C}</math>) pointing up, a bromine atom (<math>\text{Br}</math>) pointing down-left, and an ethyl group (<math>\text{H}_3\text{CH}_2\text{C}</math>) pointing down-left. The right carbon has a hydrogen atom (<math>\text{H}</math>) pointing up, a bromine atom (<math>\text{Br}</math>) pointing down-right, and an ethyl group (<math>\text{CH}_2\text{CH}_3</math>) pointing down-right.</p>
[B]	<p>Structure B: A central carbon-carbon bond. The left carbon has a bromine atom (<math>\text{Br}</math>) pointing up, a methyl group (<math>\text{H}_3\text{C}</math>) pointing down-left, and an ethyl group (<math>\text{H}_3\text{CH}_2\text{C}</math>) pointing down-left. The right carbon has a bromine atom (<math>\text{Br}</math>) pointing up, a hydrogen atom (<math>\text{H}</math>) pointing down-right, and an ethyl group (<math>\text{CH}_2\text{CH}_3</math>) pointing down-right.</p>
[C]	<p>Structure C: A central carbon-carbon bond. The left carbon has a bromine atom (<math>\text{Br}</math>) pointing up, a methyl group (<math>\text{H}_3\text{CH}_2\text{C}</math>) pointing down-left, and a hydrogen atom (<math>\text{H}</math>) pointing down-left. The right carbon has a methyl group (<math>\text{CH}_3</math>) pointing up, an ethyl group (<math>\text{CH}_2\text{CH}_3</math>) pointing down-right, and a bromine atom (<math>\text{Br}</math>) pointing down-right.</p>
<b>[D]</b>	<p>Structure D: A central carbon-carbon bond. The left carbon has a methyl group (<math>\text{H}_3\text{CH}_2\text{C}</math>) pointing up, a bromine atom (<math>\text{Br}</math>) pointing down-left, and a hydrogen atom (<math>\text{H}</math>) pointing down-left. The right carbon has a bromine atom (<math>\text{Br}</math>) pointing up, a methyl group (<math>\text{CH}_2\text{CH}_3</math>) pointing down-right, and a hydrogen atom (<math>\text{H}</math>) pointing down-right.</p>
[E]	<p>Structure E: A central carbon-carbon bond. The left carbon has a bromine atom (<math>\text{Br}</math>) pointing up, a methyl group (<math>\text{H}_3\text{CH}_2\text{C}</math>) pointing down-left, and a hydrogen atom (<math>\text{H}</math>) pointing down-left. The right carbon has a bromine atom (<math>\text{Br}</math>) pointing up, an ethyl group (<math>\text{CH}_2\text{CH}_3</math>) pointing down-right, and a methyl group (<math>\text{CH}_3</math>) pointing down-right.</p>

19. Which of A-E is the correct product **Y** after the series of the two reactions shown below?

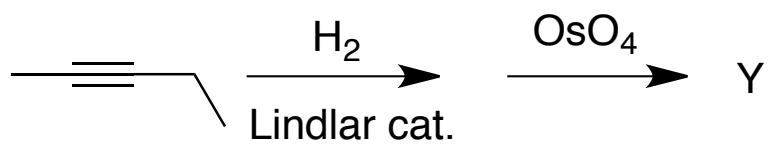

[A]	
[B]	
[C]	
[D]	
[E]	

20. One mole of a molecule with a formula  $\text{C}_{16}\text{H}_{25}\text{Br}$  decolorizes 2 moles of  $\text{Br}_2$ . Which of A-E indicates how many rings that molecule must have?

[A]	1
[B]	4
[C]	0
[D]	2
[E]	3

21. Which of A-E will **not** yield the product shown?

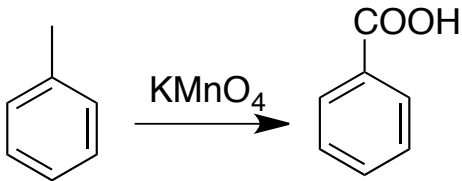
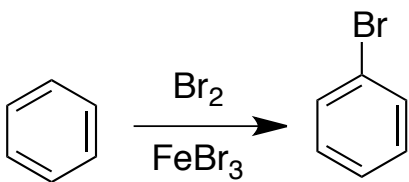
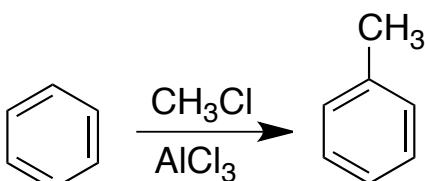
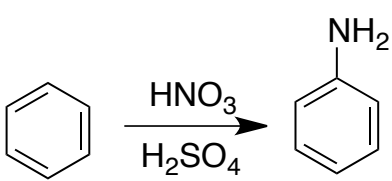
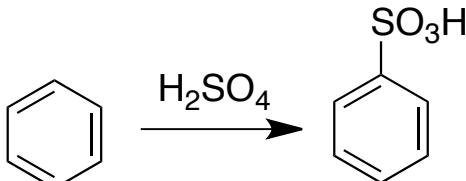
[A]	 <p>Reaction of toluene with <math>\text{KMnO}_4</math> to form benzoic acid.</p>
[B]	 <p>Reaction of benzene with <math>\text{Br}_2</math> and <math>\text{FeBr}_3</math> to form bromobenzene.</p>
[C]	 <p>Reaction of benzene with <math>\text{CH}_3\text{Cl}</math> and <math>\text{AlCl}_3</math> to form toluene.</p>
<b>[D]</b>	 <p>Reaction of benzene with <math>\text{HNO}_3</math> and <math>\text{H}_2\text{SO}_4</math> to form aniline.</p>
[E]	 <p>Reaction of benzene with <math>\text{H}_2\text{SO}_4</math> to form benzenesulfonic acid.</p>

22. Which of A-E **will** yield the product shown?

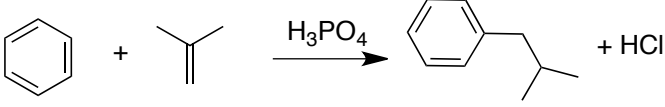
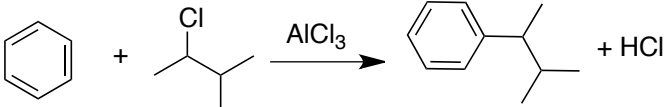
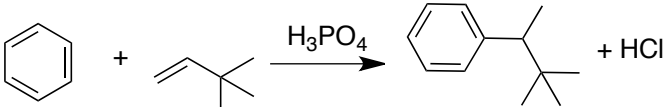
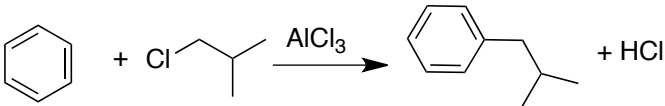
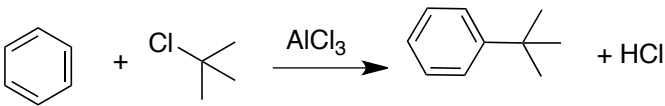
[A]	
[B]	
[C]	
[D]	
<b>[E]</b>	

23. Which of A-E is not an accurate representation of a step explaining the mechanism of a Friedel-Crafts Acylation reaction?

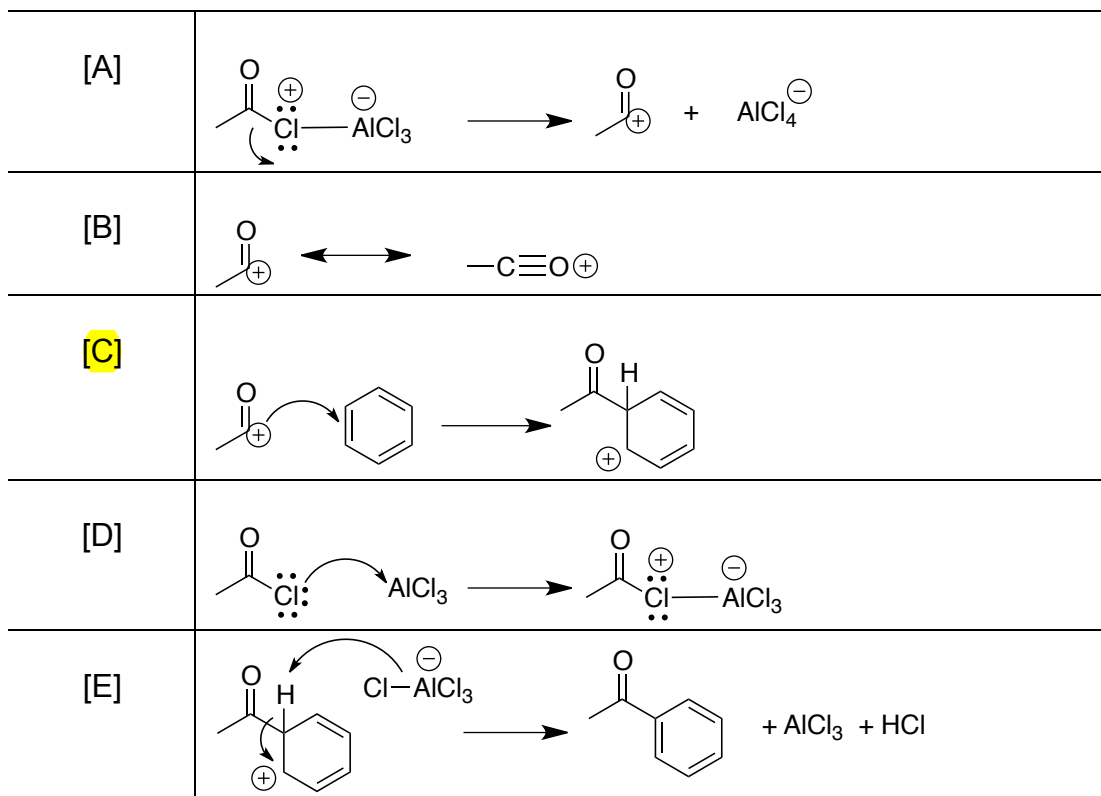

24. Which of A-E shows the molecules in order of increasing acidity (from least to most)?

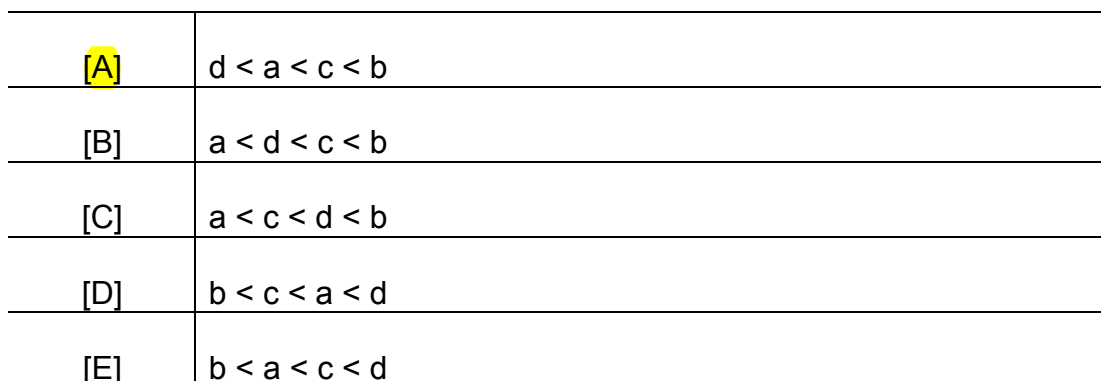
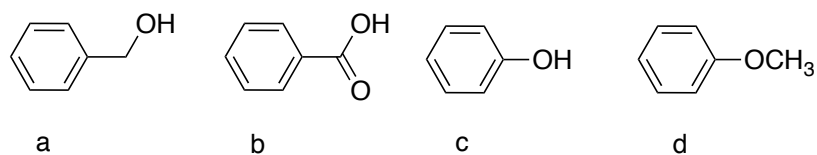

25. Which of A-E shows a reaction that **will produce** a pair of enantiomers as the major products?

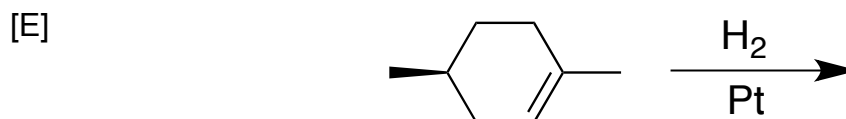
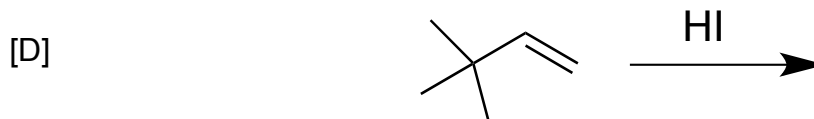
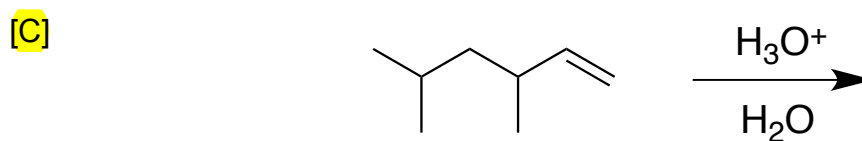
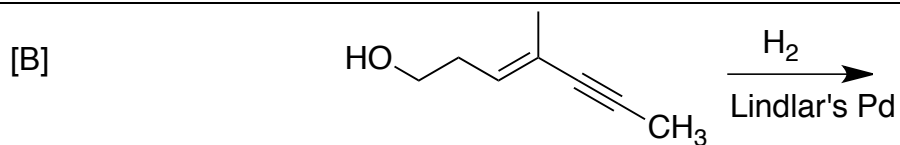
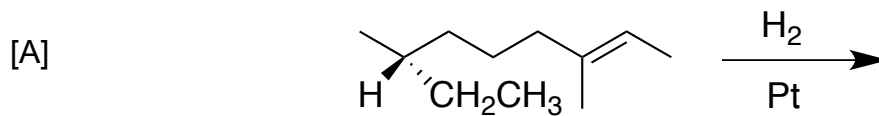

26. Which one of the following mechanistic steps occurs in the electrophilic addition of H<sub>2</sub>O to propene in the presence of catalytic H<sub>2</sub>SO<sub>4</sub>?

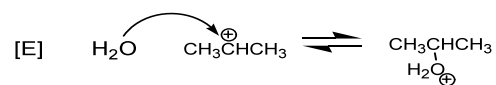
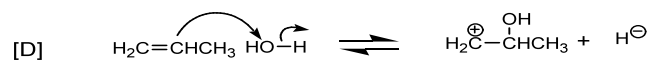
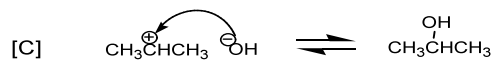
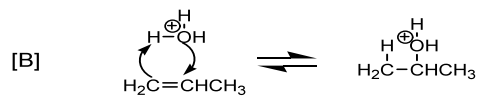
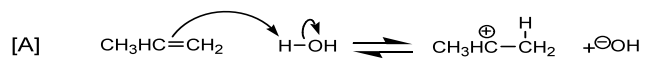

27. Which of A-E correctly identifies the member of each pair that undergoes a nucleophilic substitution in aqueous ethanol ( $\text{CH}_3\text{CH}_2\text{OH}$  in  $\text{H}_2\text{O}$ ) **most rapidly**?

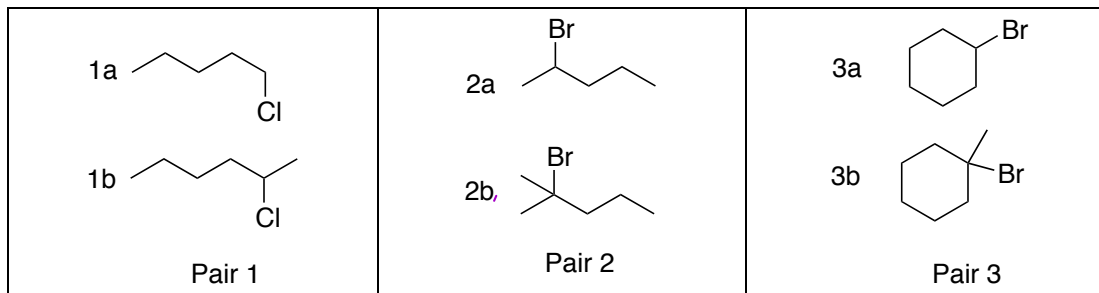

	Pair 1	Pair 2	Pair 3
[A]	1b	2b	3a
[B]	1a	2a	3b
[C]	1b	2b	3b
[D]	1a	2a	3a
<b>[E]</b>	1b	2b	3b

28. Which of A-E correctly identifies the member of each pair that undergoes the greater rate of reaction in KI in acetone ( $\text{CH}_3\text{COCH}_3$ )?

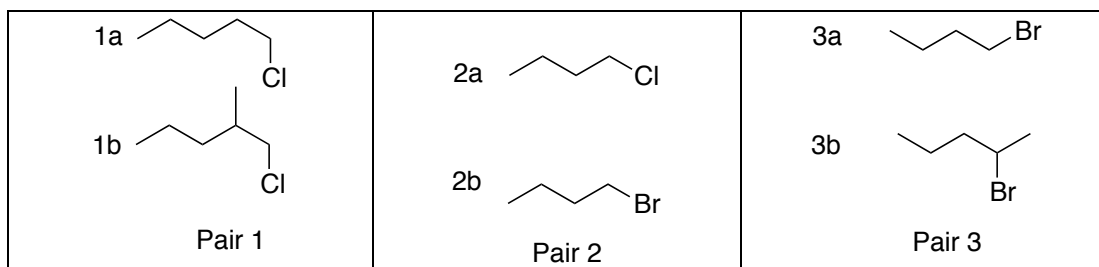

	Pair 1	Pair 2	Pair 3
[A]	1a	2a	3b
[B]	1a	2b	3a
[C]	1b	2b	3a
[D]	1a	2a	3b
<b>[E]</b>	1b	2b	3b

29. Which of A-E is the product of the following S<sub>N</sub>2 reaction?

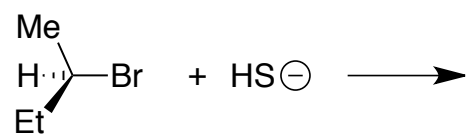

- [A]
- [B]
- [C]
- [D]
- [E] No reaction

30. Which of A-E is the **most likely** to give the product shown by the mechanism indicated?

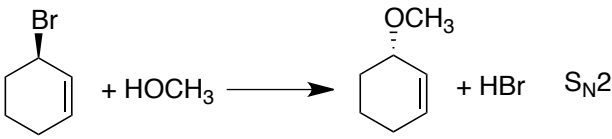
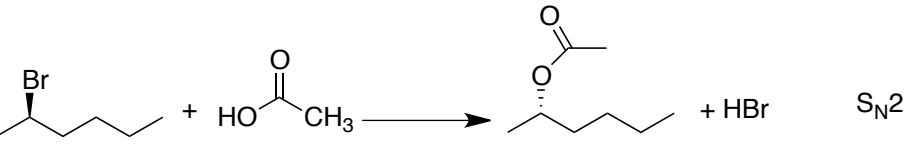
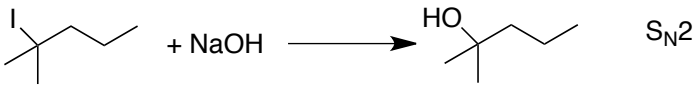
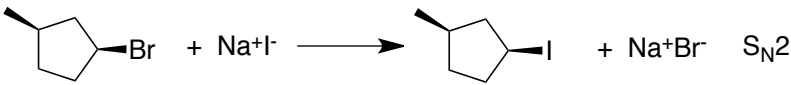
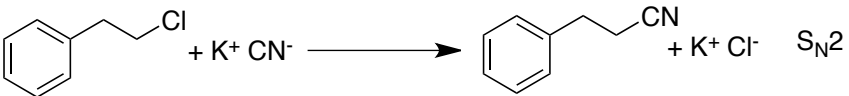
[A]	 <p>Reaction A: 1-bromo-2-methylcyclohexane + HOCH<sub>3</sub> → 1-methoxy-2-methylcyclohexane + HBr S<sub>N</sub>2</p>
[B]	 <p>Reaction B: 2-bromo-2-methylbutane + HO-C(=O)-CH<sub>3</sub> → 2-acetoxy-2-methylbutane + HBr S<sub>N</sub>2</p>
[C]	 <p>Reaction C: 2-iodo-2-methylbutane + NaOH → 2-methylbutan-2-ol S<sub>N</sub>2</p>
[D]	 <p>Reaction D: trans-1-bromo-2-methylcyclopentane + Na<sup>+</sup>I<sup>-</sup> → trans-1-iodo-2-methylcyclopentane + Na<sup>+</sup>Br<sup>-</sup> S<sub>N</sub>2</p>
[E]	 <p>Reaction E: benzyl chloride + K<sup>+</sup>CN<sup>-</sup> → benzyl cyanide + K<sup>+</sup>Cl<sup>-</sup> S<sub>N</sub>2</p>

31. Which of A-E will **not** proceed to give the product shown by an E2 mechanism?

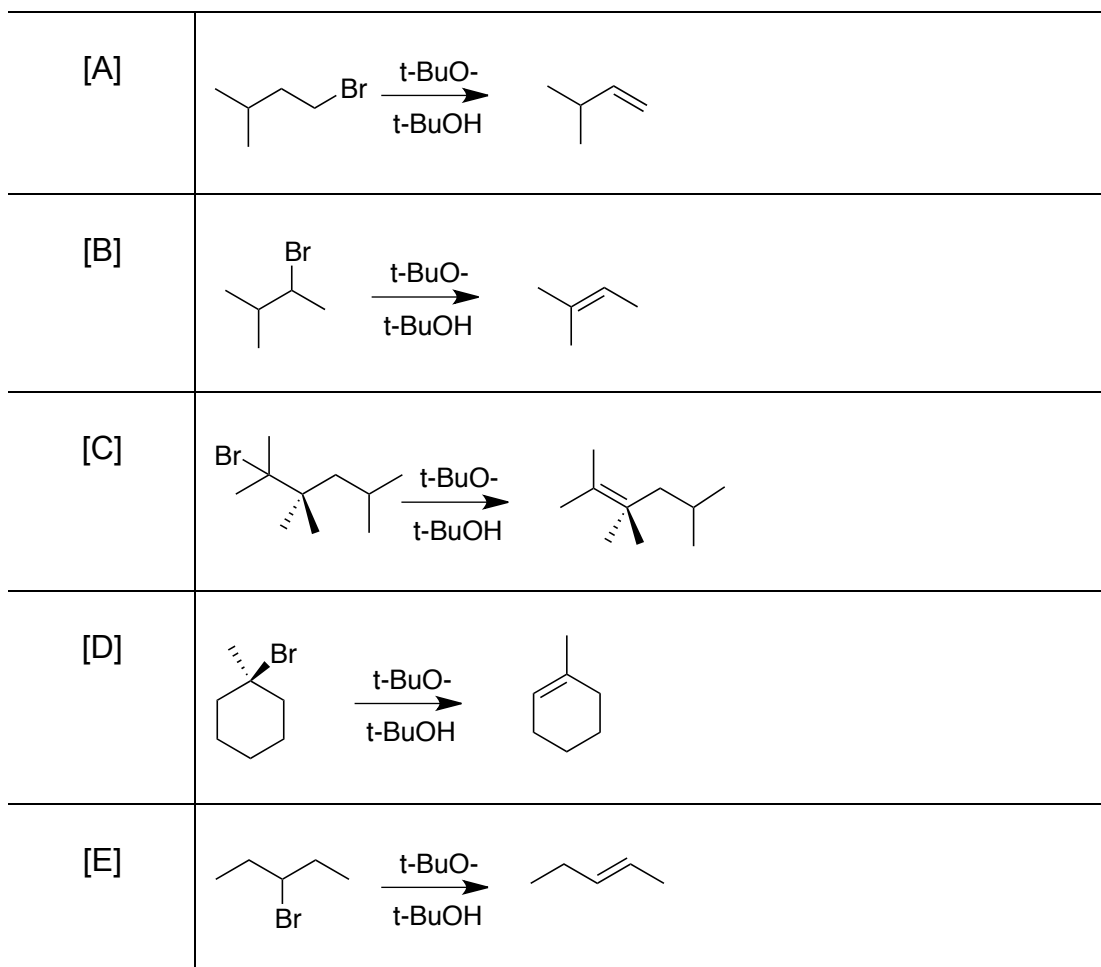

32. Which series of two reactions will yield the product indicated?

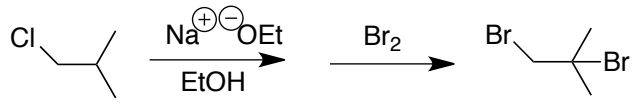
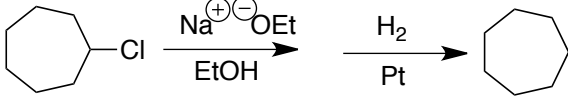
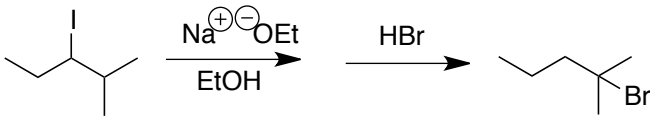
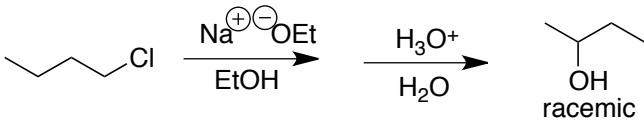
[A]	
[B]	
[C]	
[D]	
[E]	All of A-D above

33. Which of A-E correctly shows which solutions containing equal amounts of each of the pair of the structures shown would rotate plane polarized light?

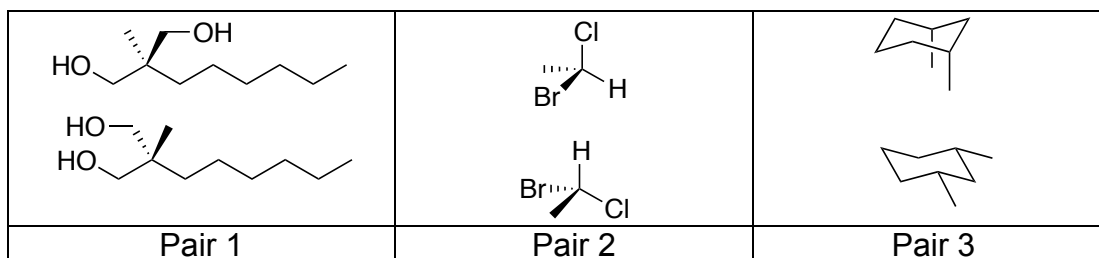

- [A] Pair 2 only  
 [B] Pair 1 only  
 [C] Pair 3 only  
 [D] Both of Pair 1 and 2  
 [E] Each of Pair 1, 2 and 3

34. Compounds **X** and **Y** are both pure compounds. Compound **X** has a melting point of 150-151 °C. Which of A-E best describes what you expect to be the melting point of a 50:50 mixture of compounds X and Y?

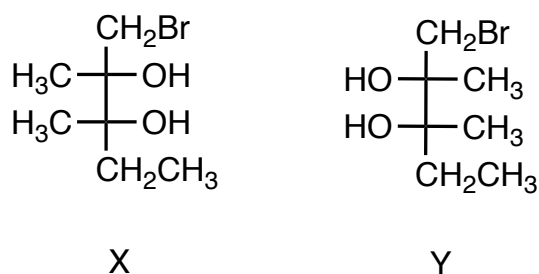

- [A] 75-80 °C  
 [B] higher than 150-151 °C  
 [C] lower and broader than 151 °C  
 [D] 150-151 °C  
 [E] 150-160 °C

35. Below is a flow chart representing the separation of an organic acidic compound (A), an organic basic compound (B) and a neutral organic compound (N) from a solution of the three in diethyl ether. The reagents used in the separation are shown beside the lines, and the identities of the liquid layers that result are shown above each box. Which of A- E identifies correctly what substance is present in BOX 7

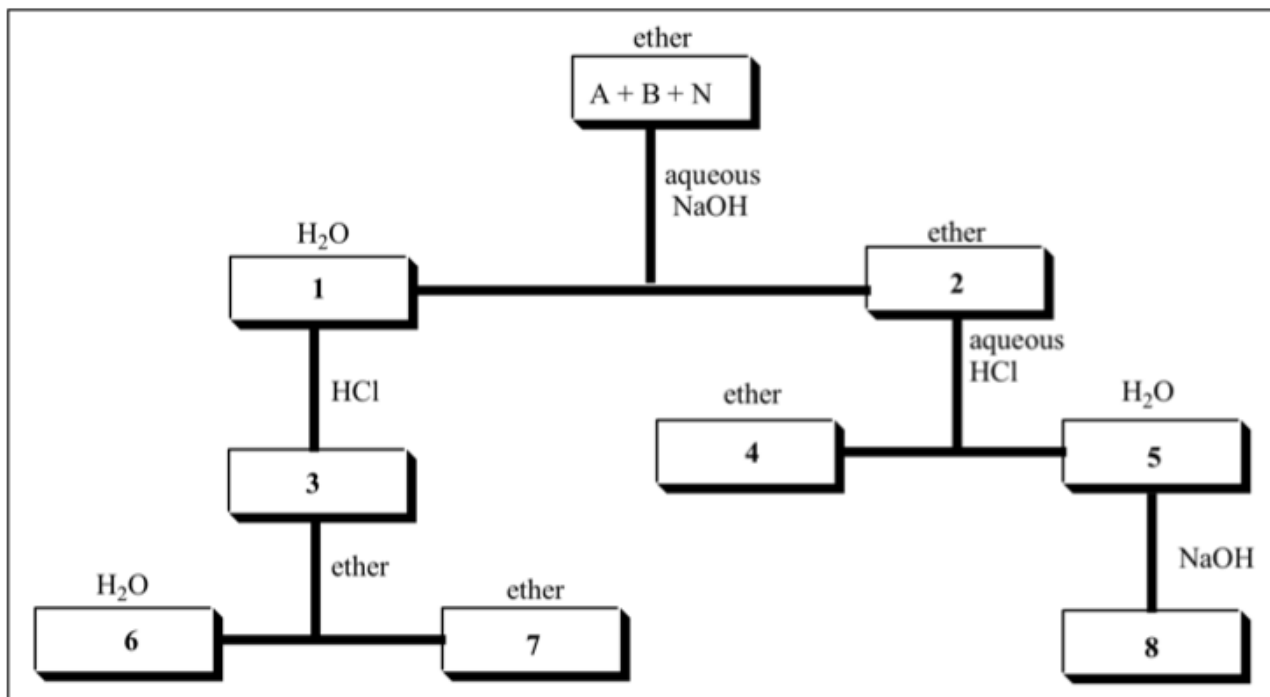

- [A] organic acid
- [B] organic base
- [C] neutral organic
- [D] organic acid salt
- [E] organic base salt