

Assignment 4 ITI 1100A

Professor: Ahmed Karmouch

4.1a)

$$T1=b'c$$

$$T2=a'b$$

$$T3=a+T1=a+b'c$$

$$T4=(d\oplus T2)=(d\oplus a'b) = d(a'b)' + d'(a'b)$$

$$=d(a+b') + d'a'b$$

$$=ad + b'd + a'bd'$$

$$F1=T4+T3$$

$$=a+b'c+ad+b'd+a'bd'$$

$$=a(d'+1)+b'c+ad+b'd+a'bd'$$

$$=ad'+a+ad+b'c+b'd+a'bd'$$

$$=a+a(d'+d)+b'c+b'd+a'bd'$$

$$=(a+a)+b'c+b'd+a'bd'$$

$$=a+b'c+b'd+bd'$$

$$F2=T2+d'=a'b+d'$$

a	b	c	d	t1	t2	t3	t4	f1	f2
0	0	0	0	0	0	0	0	0	1
0	0	0	1	0	0	0	1	1	0
0	0	1	0	1	0	1	0	1	1
0	0	1	1	1	0	1	1	1	0
0	1	0	0	0	1	0	1	1	1
0	1	0	1	0	1	0	0	0	1
0	1	1	0	0	1	0	1	1	1
0	1	1	1	0	1	0	0	0	1
1	0	0	0	0	0	1	0	1	1
1	0	0	1	0	0	1	1	1	0
1	0	1	0	1	0	1	0	1	1

1	0	1	1	1	0	1	1	1	0
1	1	0	0	0	0	1	0	1	1
1	1	0	1	0	0	1	1	1	0
1	1	1	0	0	0	1	0	1	1
1	1	1	1	0	0	1	1	1	0

f1

ab\cd	00	01	11	10
00	0	1	1	1
01	1	0	0	1
11	1	1	1	1
10	1	1	1	1

= $a+bd'+b'd+b'c$

Is equal to part a

ab\cd	00	01	11	10
00	1			1
01	1	1	1	1
11	1			1
10	1			1

= $d'+a'b$

=part a

4.5

x	y	z	A	B	C
0	0	0	0	0	1
0	0	1	0	1	0
0	1	0	0	1	1
0	1	1	1	0	0
1	0	0	0	1	0
1	0	1	0	1	1
1	1	0	1	0	0
1	1	1	1	0	1

A

xlyz	00	01	11	10
0	0	0	1	0
1	0	0	1	1

$=yz+xy$

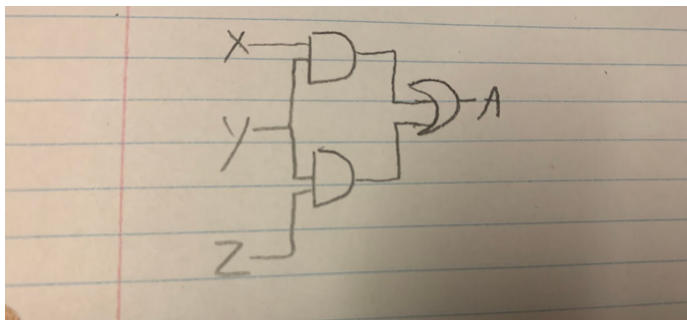

B

xlyz	00	01	11	10
0	0	1	0	1
1	1	1	0	0

$=xy'+y'z+x'yz'$

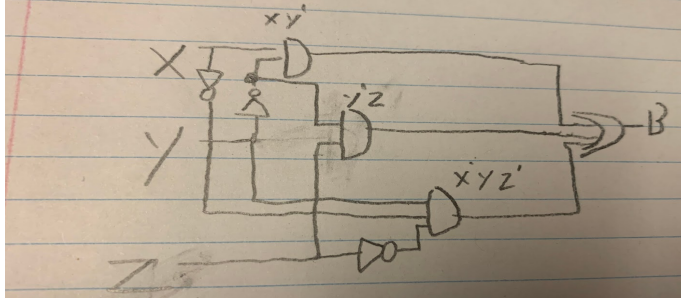

C

xlyz	00	01	11	10
0	1	0	0	1
1	0	1	1	0

$X'z'+xz$

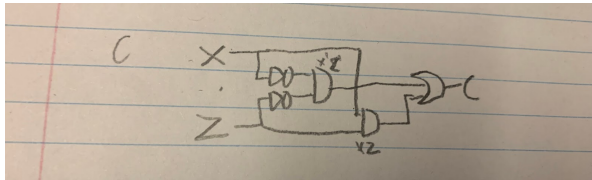

4.9

w	x	y	z	a	b	c	d	e	f	g
0	0	0	0	1	1	1	1	1	1	0
0	0	0	1	0	1	1	0	0	0	0
0	0	1	0	1	1	0	1	1	0	1
0	1	1	1	1	1	1	1	0	0	1
0	1	0	0	0	0	1	0	0	1	1
0	1	0	1	1	0	1	1	0	1	1
0	1	1	0	1	0	1	1	1	1	1
0	1	1	1	1	1	1	0	0	0	0
1	0	0	0	1	1	1	1	1	1	1
1	0	0	1	1	1	1	1	0	1	1

x	x	x	x	x	x	x	x	x	x	x
x	x	x	x	x	x	x	x	x	x	x
x	x	x	x	x	x	x	x	x	x	x
x	x	x	x	x	x	x	x	x	x	x
x	x	x	x	x	x	x	x	x	x	x
x	x	x	x	x	x	x	x	x	x	x

A

ab\cd	00	01	11	10
00	1	0	1	1
01	0	1	1	1
11	x	x	x	x
10	1	1	x	x

$a+c+bd+a'b'd'$

B

ab\cd	00	01	11	10
00	1	1	1	1
01	0	0	1	0
11	x	x	x	x
10	1	1	x	x

$A+b'+cd$

C

ab\cd	00	01	11	10
00	1	1	1	0
01	1	1	1	1
11	x	x	x	x
10	1	1	x	x

$b+a'+d$

D

ab\cd	00	01	11	10
00	1	0	1	1
01	0	1	0	1
11	x	x	x	x
10	1	1	x	x

$A+cb'+cd'+b'c+b'd'+bc'd$

E

ab\cd	00	01	11	10
00	1	0	0	1
01	0	0	0	1
11	x	x	x	x
10	1	0	x	x

$B'd'+ab'$

F

ab\cd	00	01	11	10
00	1	0	0	0
01	1	1	0	1
11	x	x	x	x
10	1	1	x	x

$A+a'b'+bc'+bd'$

G

ab\cd	00	01	11	10
00	0	0	1	1
01	1	1	0	1
11	x	x	x	x
10	1	1	x	x

$A+b'c+cd'+bc'$

4.21)

$(a_0, a_1, a_2, a_3) = (b_0, b_1, b_2, b_3)$

$a_0b_0 + a_0'b_0' = 1$ if equal

Therefore $(a_0 \oplus b_0)'$

Continue for all variables

$Y = (a_0 \oplus b_0)'(a_1 \oplus b_1)'(a_2 \oplus b_2)'(a_3 \oplus b_3)'$

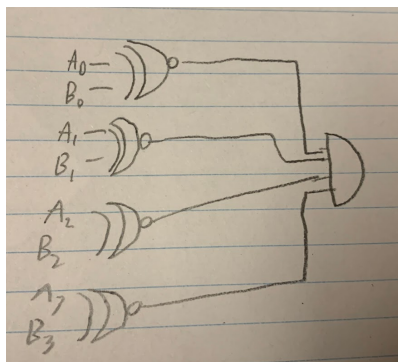

4.23)

E is enabler

a) $d_0 = a_1'a_0'e = (a_1 + a_0 + e)'$

$d_1 = a_1'a_0e = (a_1 + a_0' + e)'$

$d_2 = a_1a_0'e = (a_1' + a_0 + e)'$

$d_3 = a_1a_0e = (a_1' + a_0' + e)'$

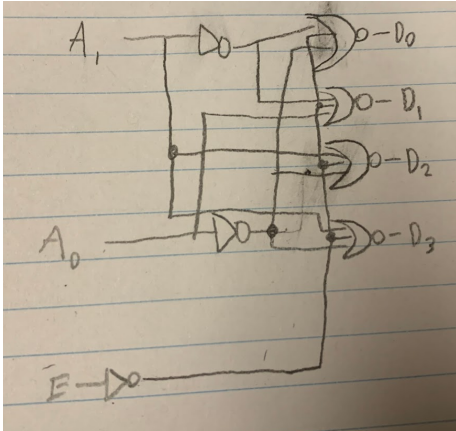

b) $d_0' = (a_1'a_0'e)'$

$d_1' = (a_1'a_0e)'$

$d_2' = (a_1a_0'e)'$

$d_3' = (a_1a_0e)'$

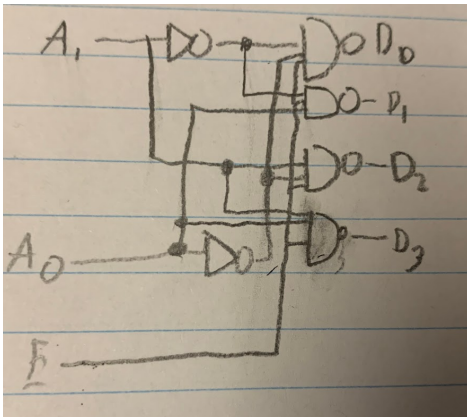

4.27

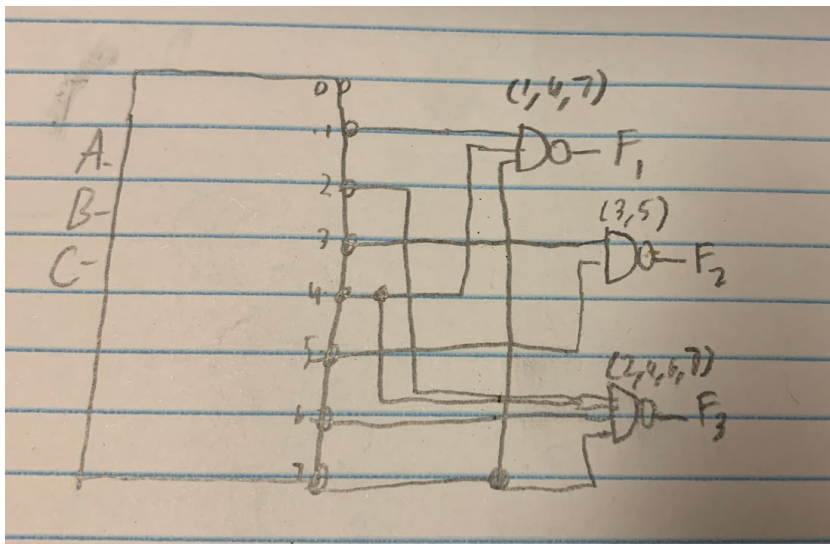

4.28

	x	y	z
0	0	0	0
1	0	0	1
2	0	1	0
3	0	1	1
4	1	0	0
5	1	0	1
6	1	1	0
7	1	1	1

(Table is just for reference of where on decoder each product is)

a) $f_1 = x'yz + xz$

$f_1 = x'yz + xy'z + xyz$

$f_2 = xy'z' + x'y$

$f_2 = xy'z' + x'yz + x'yz'$

$f_3 = x'y'z' + xy$

$f_3 = x'y'z' + xyz + xyz'$

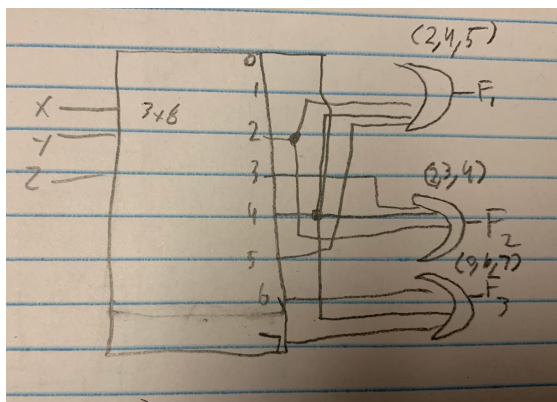

b) $f_1 = zy' + zx$

$= xy'z + z'y'z + xyz$

$f_2 = y'z' + x'y + yz'$

$= xy'z' + z'y'z' + x'yz + x'yz' + xyz'$

$f_3 = xy + xz$

$= xyz + xyz' + xy'z$

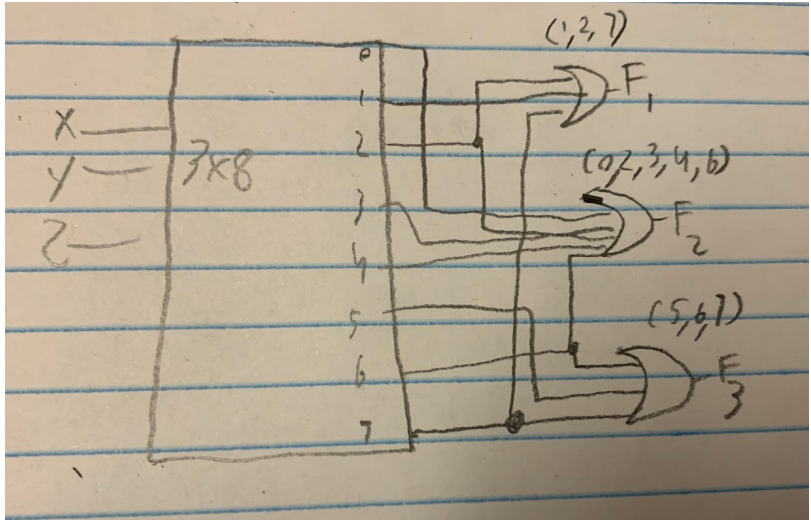

4.33)

x	y	z	c	s
0	0	0	0	0
0	0	1	0	1
0	1	0	0	1
0	1	1	1	0
1	0	0	0	1
1	0	1	1	0
1	1	0	1	0
1	1	1	1	1

