

CVG2140 – Solutions to Assignment No. 2 (Centroids and Moments of Inertia)

Problem 1. Calculate the position of the centroid of the shape shown in Fig. 1.

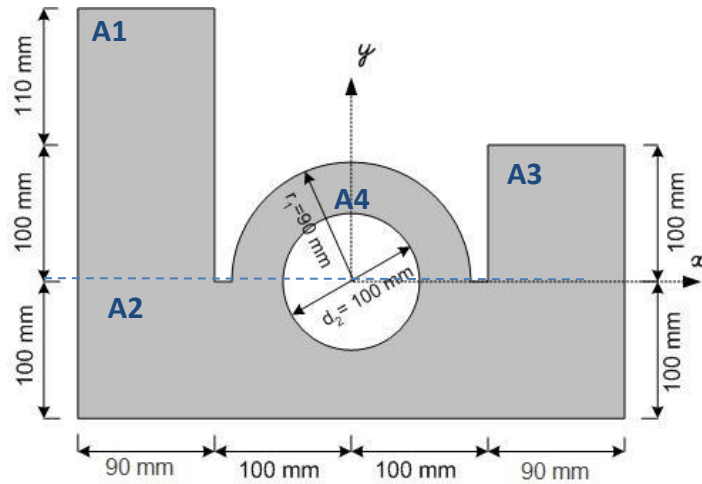

Fig. 1

		A (mm ²)	\bar{x}_i (mm)	\bar{y}_i (mm)	$\bar{x}_i \cdot A_i$ (mm ³)	$\bar{y}_i \cdot A_i$ (mm ³)
A1	Vertical rectangle	18,900	-145	105	-2,740,500	1,984,500
A2	Horizontal rectangle	38,000	0	-50	0	-1,900,000
A3	Square	9,000	145	50	1,305,000	450,000
A4	Semicircle	12,723.45	0	38.19	0	485,909
A5	Empty circle	-7,854.00	0	0	0	0
Σ		70,769.45			-1,435,500.00	1,020,408.56

$$\bar{x} = \frac{\sum \bar{x}_i \cdot A_i}{\sum A_i} = -20.28 \text{ mm}$$

$$\bar{y} = \frac{\sum \bar{y}_i \cdot A_i}{\sum A_i} = 14.42 \text{ mm}$$

Problem 2. Calculate the moments of inertia I_x , I_y , J_o , I_{xy} of the section shown in Fig. 2 with respect to a coordinate system located at the centroid. (Dimensions are in mm).

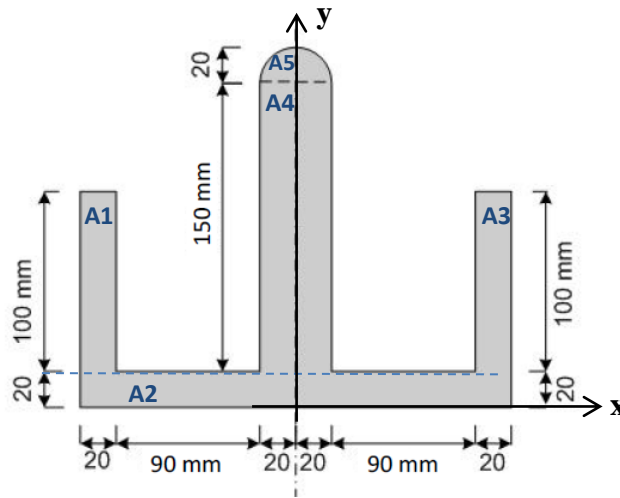

Fig. 2

(1) Centroid

		A (mm ²)	\bar{x}_i (mm)	\bar{y}_i (mm)	$\bar{x}_i \cdot A_i$ (mm ³)	$\bar{y}_i \cdot A_i$ (mm ³)
A1	Vertical rectangle	2,000	-120	70	-240,000	140,000
A2	Horizontal rectangle	5,200	0	10	0	52,000
A3	Vertical rectangle	2,000	120	70	240,000	140,000
A4	Middle rectangle	6,000	0	95	0	570,000
A5	Semicircle	628	0	178.5	0	112,093
Σ		15,828.00			0.00	1,014,093.33

$$\bar{x} = \frac{\sum \bar{x}_i \cdot A_i}{\sum A_i} = 0 \text{ mm (symmetric with respect to } Y_c)$$

$$\bar{y} = \frac{\sum \bar{y}_i \cdot A_i}{\sum A_i} = 64.07 \text{ mm (from the bottom)}$$

(2) Moments of inertia

- Note that the parallel axis theorem always refers to the centroidal axis of each area.
- The moments of inertia of each area with respect to their own centroidal axes are denoted here by I'_{xc} and I'_{yc} , respectively.
- For area A5, top semicircle, the value given for I'_{xc} is obtained from the formulas in the diagram below, i.e.,

$$I_{BB} = I'_{xc} + Ad^2 \Rightarrow$$

$$I'_{xc} = I_{BB} - Ad^2 = \frac{\pi r^4}{8} - \left(\frac{\pi r^2}{2}\right) \left(\frac{4r}{3\pi}\right)^2 = 62,831.85 - (628.32)(8.49)^2 = 17,542.48 \text{ mm}^4$$

Semicircle (origin of axes at centroid)

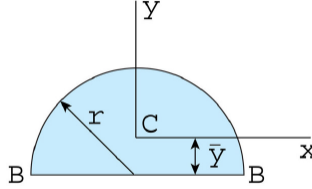

$$A = \frac{\pi r^2}{2}, \quad \bar{y} = \frac{4r}{3\pi}$$

$$I_x = \frac{(9\pi^2 - 64)r^4}{72\pi} \approx 0.1098r^4, \quad I_y = \frac{\pi r^4}{8}, \quad I_{xy} = 0$$

$$I_{BB} = \frac{\pi r^4}{8}$$

	A (mm ²)	I' _{xc} (mm ⁴)	I' _{yc} (mm ⁴)	d _x (mm)	d _y (mm)	Ad _x ² (mm ⁴)	Ad _y ² (mm ⁴)	I _{xc} = I' _{xc} + Ad _x ² (mm ⁴)	I _{yc} = I' _{yc} + Ad _y ² (mm ⁴)	J _c = I _{xc} + I _{yc} (mm ⁴)
A1	2,000	1,666,667	66,667	5.92	-120	70,093	28,800,000	1,736,759	28,866,667	30,603,426
A2	5,200	173,333	29,293,333	-54.08	0	15,208,161	0	15,381,495	29,293,333	44,674,828
A3	2,000	1,666,667	66,667	5.92	120	70,093	28,800,000	1,736,759	28,866,667	30,603,426
A4	6,000	11,250,000	800,000	30.92	0	5,736,278	0	16,986,278	800,000	17,786,278
A5	628	17,524	62,831	114.41	0	8,220,668	0	8,238,192	62,831	8,301,023
Σ	15,828.00							44,079,484.12	87,889,497.67	131,968,981.79

From the above table the moments of inertia are given by:

$$I_x = I_{xc} = 44,079,484.12 \text{ mm}^4$$

$$I_y = I_{yc} = 87,889,497.67 \text{ mm}^4$$

$$J_o = J_c = 131,968,981.79 \text{ mm}^4$$

(3) Product of inertia

All the areas have a vertical axis of symmetry; therefore, the product of inertia with respect to the centroidal axes is zero. Note that the product of inertia with respect to an axis of symmetry is zero. This is also applicable for the composite area, since it is symmetric with respect to the vertical centroidal axis y-y. This can be proved by calculating it as shown in the following table, although it is not necessary for the solution of this problem.

	A (mm ²)	I' _{xy} (mm ⁴)	d _x (mm)	d _y (mm)	Ad _x d _y (mm ⁴)	I _{xy} = I' _{xy} + Ad _x d _y (mm ⁴)
A1	2,000	0	5.92	-120	-1,420,800	-1,420,800
A2	5,200	0	-54.08	0	0	0
A3	2,000	0	5.92	120	1,420,800	1,420,800
A4	6,000	0	30.92	0	0	0
A5	628	0	114.41	0	0	0
Σ	15,828					0

Problem 3. For a coordinate system located at the centroid, calculate the maximum and minimum values of the moments of inertia I_{\max} and I_{\min} (obtained by rotating the axes) and the corresponding angles of the section shown in Fig. 3. (Dimensions are in mm).

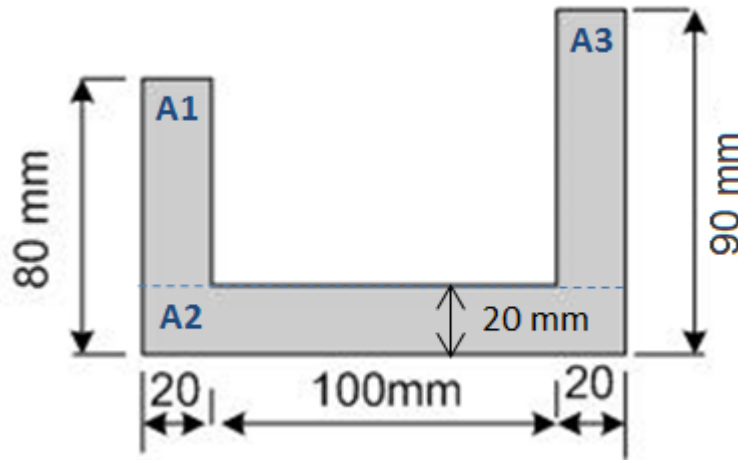

Fig. 3

(1) Centroid

		A (mm ²)	\bar{x}_i (mm)	\bar{y}_i (mm)	$\bar{x}_i \cdot A_i$ (mm ³)	$\bar{y}_i \cdot A_i$ (mm ³)
A1	Vertical rectangle	1,200.00	10	50	12,000	60,000
A2	Horizontal rectangle	2,800.00	70	10	196,000	28,000
A3	Vertical rectangle	1,400.00	130	55	182,000	77,000
Σ		5,400.00			390,000.00	165,000.00

$$\bar{x} = \frac{\sum \bar{x}_i \cdot A_i}{\sum A_i} = 72.22 \text{ mm (from the left edge)}$$

$$\bar{y} = \frac{\sum \bar{y}_i \cdot A_i}{\sum A_i} = 30.56 \text{ mm (from the bottom)}$$

(2) Moments of inertia with respect to the centroid

	A (mm ²)	I'_{xc} (mm ⁴)	I'_{yc} (mm ⁴)	d_x (mm)	d_y (mm)	Ad_x^2 (mm ⁴)	Ad_y^2 (mm ⁴)	$I_{xc} = I'_{xc} + Ad_x^2$ (mm ⁴)	$I_{yc} = I'_{yc} + Ad_y^2$ (mm ⁴)
A1	1,200	360,000.00	40,000.00	19.44	-62.22	453,703.70	4,645,925.93	813,703.70	4,685,925.93
A2	2,800	93,333.33	4,573,333.33	-20.56	-2.22	1,183,086.42	13,827.16	1,276,419.75	4,587,160.49
A3	1,400	571,666.67	46,666.67	24.44	57.78	836,543.21	4,673,580.25	1,408,209.88	4,720,246.91
Σ	5,400							3,498,333.33	13,993,333.33

From the above table the moments of inertia are given by:

$$I_x = I_{xc} = 3,498,333.33 \text{ mm}^4$$

$$I_y = I_{yc} = 13,993,333.33 \text{ mm}^4$$

(4) Product of inertia with respect to the centroid

	A (mm ²)	I'_{xy} (mm ⁴)	d_x (mm)	d_y (mm)	Ad_xd_y (mm ⁴)	$I_{xy} = I'_{xy} + Ad_xd_y$ (mm ⁴)
A1	1,200	0	19.44	-62.22	-1,451,851.85	-1,451,851.85
A2	2,800	0	-20.56	-2.22	127,901.23	127,901.23
A3	1,400	0	24.44	57.78	1,977,283.95	1,977,283.95
Σ	5,400					653,333.33

$$I_{xcyc} = I_{xy} = 653,333.33 \text{ mm}^4$$

(5) Principal moments of inertia and corresponding directions

$$\tan 2\theta = -\frac{2I_{xcyc}}{I_{xc} - I_{yc}} = -\frac{2 \times 653,333.33}{3,498,333.33 - 13,993,333.33} \Rightarrow \begin{cases} \theta_2 = 3.55^\circ \\ \theta_1 = 93.55^\circ \end{cases}$$

$$\begin{aligned} I_{x'} &= \frac{I_{xc} + I_{yc}}{2} + \frac{I_{xc} - I_{yc}}{2} \cos(2 \times 3.55) - I_{xcyc} \sin(2 \times 3.55) \\ &= \frac{3,498,333.33 + 13,993,333.33}{2} + \frac{3,498,333.33 - 13,993,333.33}{2} \cos(2 \times 3.55) - [653,333.33 \times \sin(2 \times 3.55)] \\ &= 3,457,818.522 \text{ mm}^4 = I_{\min} \end{aligned}$$

$$\begin{aligned} I_{y'} &= \frac{I_{xc} + I_{yc}}{2} - \frac{I_{xc} - I_{yc}}{2} \cos(2 \times 93.55) - I_{xcyc} \sin(2 \times 93.55) \\ &= \frac{3,498,333.33 + 13,993,333.33}{2} - \frac{3,498,333.33 - 13,993,333.33}{2} \cos(2 \times 93.55) - [653,333.33 \times \sin(2 \times 93.55)] \\ &= 14,033,848.14 \text{ mm}^4 = I_{\max} \end{aligned}$$