

Last Name	First Name	ID
------------------	-------------------	-----------

ELEC 2607

Assignment 2

15 Marks

1. Prove or disprove that the function $Z = ab + c(a + b)$ is self-dual. Note that self-dual functions satisfy the property $\overline{f(a, b, c)} = f(\overline{a}, \overline{b}, \overline{c})$. 2 marks

2. Convert the following NAND-NOR circuit to an AND-OR circuit (bubbles i.e. inverters allowed). 3 marks

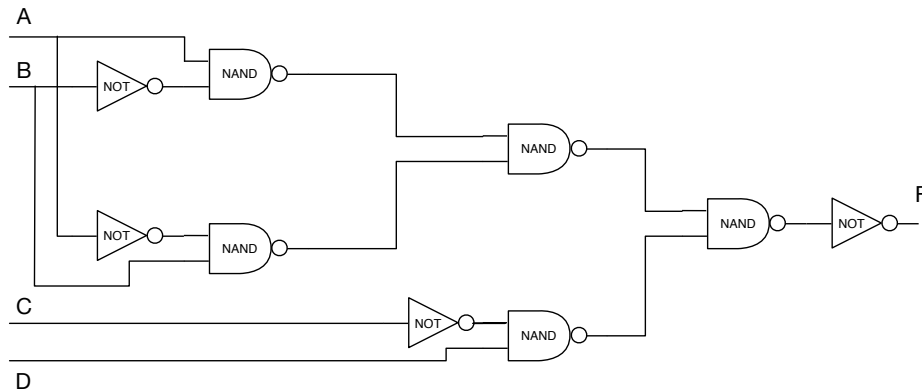

3. Perform the following conversions by showing your work.

4 marks

(a) $(11001.001)_2 = (?)_{10}$

(b) $(1001110.11)_2 = (?)_8$

(c) $(1001110.11)_2 = (?)_{16}$

(d) $AE72.B = (?)_2$

(e) $(125.86)_{10} = (?)_2$ upto 3 fractional digits

(f) $9F82.E = (?)_{10}$

4. Let $A = 10101101$, $B = 01100110$ be two numbers encoded using the 2's complement system with 8 bits. Perform the following operations and indicate if there is an overflow.

2 marks

(a) $A + B$

(b) $A - B$

(c) $B - A$

(d) $-A - B$

5. Draw the K-Map for the expression $Z = \bar{a}bc + d\bar{c}b + adc + \bar{a}cd + \bar{a}\bar{c}d + \bar{a}\bar{b}c\bar{d}$. Using the K-Map reduce the expression to its simplest form. 2 marks

6. Find a simplified expression for the following K-Maps. 2 mark

				c	
				d	
		1	0	d	d
	b	0	d	1	0
	0	0	1	d	0
a	d	d	0	1	