



GNG 1105/ 1505
 ENGINEERING MECHANICS

Final Examination April 25th, 2017

Duration: 3 hours

Number of pages: 2

Profs: Ph. Girault, B. Momenan and A. Eter

Closed book examination; programmable calculators are not allowed.

Free-body diagrams must be drawn where applicable.

Problem 1. (20/100) The truss shown is loaded by two forces $P = 8 \text{ kN}$. All joints are pinned.

- (a) Determine the reactions at the supports D and E.
- (b) Using the method of sections, determine the forces in members BD, BE and CE in the truss, specifying for each whether it is in tension or compression.

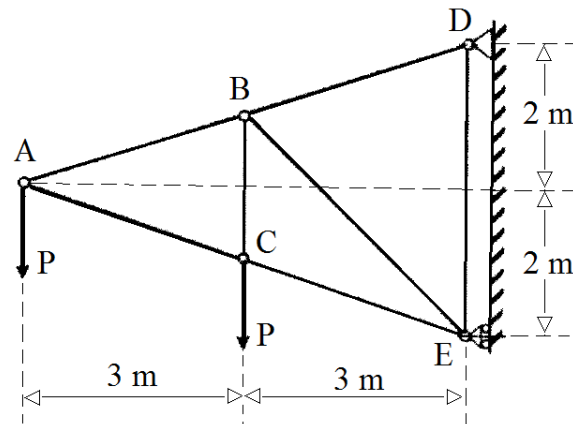

Problem 2. (20/100) For the frame and loading shown, determine the components of all forces acting on member ABE .

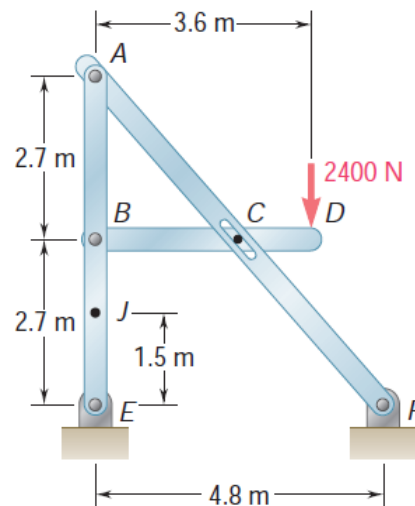

Problem 3. (20/100) A 30 kg cover for a roof-opening is hinged at corners A and B, The roof forms an angle of 30° with the horizontal, and the cover is maintained in a horizontal position by the brace CE. Determine:

- (a) The magnitude of the force exerted by the brace CE,
- (b) The reactions at the hinges A & B. Assume that the hinge at A does not exert any axial thrust.

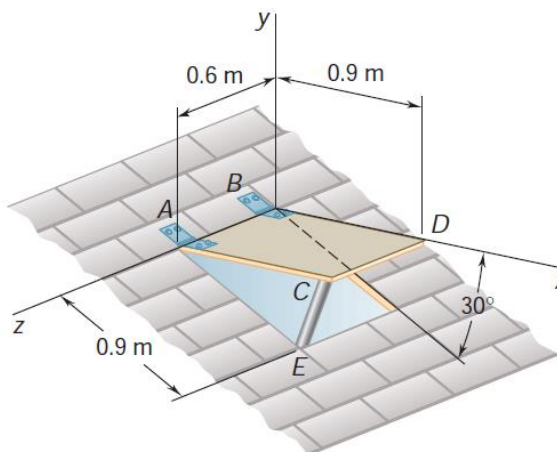

Problem 4. (20/100) The coefficients of friction are $\mu_s = 0.40$ and $\mu_k = 0.30$ between all surfaces of contact. Determine the smallest force P required to start the 30-kg block moving if cable AB is attached as shown.

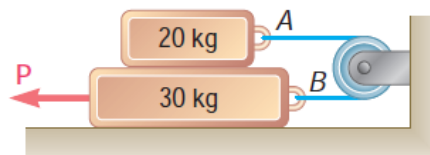

Problem 5. (20/100) A ball is thrown from the top of a 20 m high tower with an initial velocity of $V_0 = 10$ m/s in the direction shown.

- (a) Determine the x and y coordinates of the point at which the ball strikes the slope.
- (b) Determine the velocity of the ball at the point at which it strikes the slope.

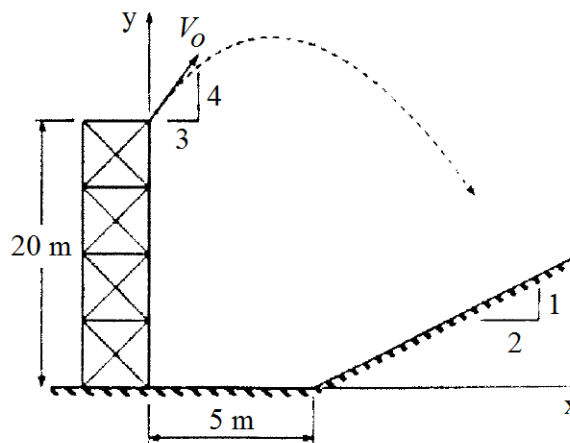

Useful Equations:

$$\begin{aligned}
 x &= x_o + vt & x &= x_o + v_o t + \frac{1}{2}at^2 & \sum \vec{F} &= m\vec{a} \\
 v &= v_o + at & v^2 &= v_o^2 + 2a(x - x_o) & \sum \vec{F}_x &= m\vec{a}_x \\
 & & & & \sum \vec{F}_y &= m\vec{a}_y \\
 & & & & \sum \vec{F}_z &= m\vec{a}_z
 \end{aligned}$$