

Chapter 2

Energy and the First Law of Thermodynamics

Learning Outcomes

- ▶ **Explain key concepts** related to **energy** and the **first law of thermodynamics**. . . including internal, kinetic, and potential energy, work and power, heat transfer and heat transfer modes, heat transfer rate, power cycle, refrigeration cycle, and heat pump cycle.

Learning Outcomes, cont.

- ▶ **Analyze closed systems** including applying energy balances, appropriately modeling the case at hand, and correctly observing sign conventions for work and heat transfer.
- ▶ **Conduct energy analyses** of systems undergoing thermodynamic cycles, evaluating as appropriate thermal efficiencies of power cycles and coefficients of performance of refrigeration and heat pump cycles.

Closed System Energy Balance

- ▶ Energy is an extensive property that includes the kinetic and gravitational potential energy of engineering mechanics.
- ▶ For closed systems, energy is transferred in and out across the system boundary by two means only: by work and by heat.
- ▶ Energy is conserved. This is the first law of thermodynamics.

Closed System Energy Balance

- ▶ The closed system energy balance states:

$$\left[\begin{array}{c} \text{The } \textit{change} \text{ in the} \\ \text{amount of energy} \\ \text{contained within} \\ \text{a closed system} \\ \text{during some time} \\ \text{interval} \end{array} \right] = \left[\begin{array}{c} \textit{Net} \text{ amount of energy} \\ \text{transferred in and out} \\ \text{across the system boundary} \\ \text{by heat and work during} \\ \text{the time interval} \end{array} \right]$$

- ▶ We now consider several aspects of the energy balance, including what is meant by **energy change** and **energy transfer**.

Change in Energy of a System

In engineering thermodynamics the **change in energy of a system** is composed of three contributions:

- ▶ Kinetic energy
- ▶ Gravitational potential energy
- ▶ Internal energy

Change in Kinetic Energy

- ▶ The change in kinetic energy is associated with the **motion of the system as a whole relative to an external coordinate frame** such as the surface of the earth.
- ▶ For a system of mass m the change in kinetic energy from state 1 to state 2 is

$$\Delta KE = KE_2 - KE_1 = \frac{1}{2}m(V_2^2 - V_1^2) \quad \text{(Eq. 2.5)}$$

where

- ▶ V_1 and V_2 denote the initial and final velocity magnitudes.
- ▶ The symbol Δ denotes: final value minus initial value.

Change in Gravitational Potential Energy

- ▶ The change in gravitational potential energy is associated with the **position of the system in the earth's gravitational field**.
- ▶ For a system of mass m the change in potential energy from state 1 to state 2 is

$$\Delta PE = PE_2 - PE_1 = mg(z_2 - z_1) \quad \text{(Eq. 2.10)}$$

where

- ▶ z_1 and z_2 denote the initial and final elevations relative to the surface of the earth, respectively.
- ▶ g is the acceleration of gravity.

Change in Internal Energy

- ▶ The change in internal energy is associated with the **makeup of the system, including its chemical composition**.
- ▶ There is no simple expression comparable to **Eqs. 2.5** and **2.10** for evaluating internal energy change for a wide range of applications. In most cases we will evaluate internal energy change using **data from tables** in appendices of the textbook.
- ▶ Like kinetic and gravitational potential energy, **internal energy is an extensive property**.
 - ▶ Internal energy is represented by U .
 - ▶ The specific internal energy on a mass basis is u .
 - ▶ The specific internal energy on a molar basis is \bar{u} .

Change in Energy of a System

► In summary, the **change** in energy of a system from state 1 to state 2 is

$$E_2 - E_1 = (U_2 - U_1) + (KE_2 - KE_1) + (PE_2 - PE_1)$$

(Eq. 2.27a)

$$\Delta E = \Delta U + \Delta KE + \Delta PE \quad \textbf{(Eq. 2.27b)}$$

► Since an arbitrary value E_1 can be assigned to the energy of a system at a given state 1, no particular significance can be attached to the value of energy at state 1 or any other state. Only **changes** in the **energy** of a system between states **have significance**.

Energy Transfer by Work

▶ Energy can be transferred to and from closed systems by two means only:

▶ Work

▶ Heat

▶ You have studied work in mechanics and those concepts are retained in the study of thermodynamics. However, **thermodynamics deals with phenomena not included within the scope of mechanics, and this requires a broader interpretation of work.**

Illustrations of Work

▶ When a **spring is compressed**, energy is transferred to the spring by work.

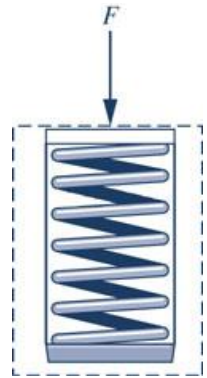

▶ When a **gas in a closed vessel is stirred**, energy is transferred to the gas by work.

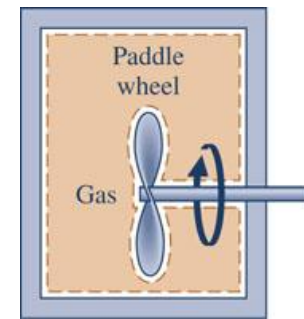

▶ When a **battery is charged electrically**, energy is transferred to the battery contents by work.

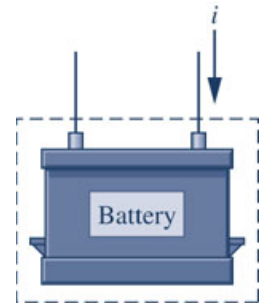

▶ The **first two examples of work** are encompassed by **mechanics**. The **third example** is an example of the **broader interpretation of work encountered in thermodynamics**.

Energy Transfer by Work

▶ The symbol W denotes an **amount of energy transferred** across the boundary of a system **by work**.

▶ Since engineering thermodynamics is often concerned with internal combustion engines, turbines, and electric generators whose purpose is to do work, **it is convenient to regard the work done by a system as positive**.

▶ $W > 0$: work **done by** the system

▶ $W < 0$: work **done on** the system

The same sign convention is used for the **rate of energy transfer by work** – called **power**, denoted by \dot{W} .

Energy Transfer by Heat

- ▶ Energy transfers by heat are induced only as a result of a temperature difference between the system and its surroundings.
- ▶ Net energy transfer by heat occurs only in the direction of decreasing temperature.

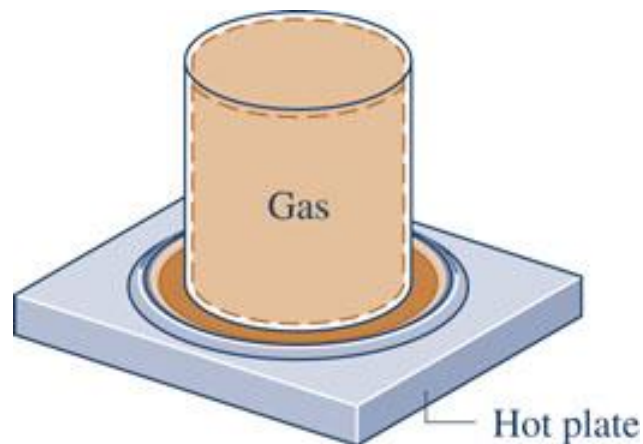

Energy Transfer by Heat

- ▶ The symbol Q denotes an **amount of energy transferred** across the boundary of a system **by heat transfer**.
- ▶ Heat transfer **into a system** is taken as **positive** and heat transfer **from a system** is taken as **negative**:
 - ▶ $Q > 0$: heat transfer **to the** system
 - ▶ $Q < 0$: heat transfer **from** the system

The same sign convention is used for the **rate of energy transfer by heat**, denoted by \dot{Q} .

- ▶ If a system undergoes a process involving **no heat transfer** with its surroundings, that process is called ***adiabatic***.

Summary: Closed System Energy Balance

► The energy concepts introduced thus far are summarized in words as follows:

$$\left[\begin{array}{l} \textit{change} \text{ in the amount} \\ \text{of energy contained} \\ \text{within a system} \\ \text{during some time} \\ \text{interval} \end{array} \right] = \left[\begin{array}{l} \textit{net} \text{ amount of energy} \\ \text{transferred } \textit{in} \text{ across} \\ \text{the system boundary by} \\ \textit{heat transfer} \text{ during} \\ \text{the time interval} \end{array} \right] - \left[\begin{array}{l} \textit{net} \text{ amount of energy} \\ \text{transferred } \textit{out} \text{ across} \\ \text{the system boundary} \\ \text{by } \textit{work} \text{ during the} \\ \text{time interval} \end{array} \right]$$

► Using previously defined symbols, this can be expressed as: $E_2 - E_1 = Q - W$ (Eq. 2.35a)

► Alternatively, $\Delta KE + \Delta PE + \Delta U = Q - W$ (Eq. 2.35b)

In Eqs. 2.35, a **minus sign** appears **before W** because energy transfer by work from the system to the surrounding is taken as positive.

Summary: Closed System Energy Balance

▶ The **time rate form** of the closed system energy balance is

$$\frac{dE}{dt} = \dot{Q} - \dot{W} \quad \text{(Eq. 2.37)}$$

▶ The rate form expressed in words is

$$\left[\begin{array}{l} \text{time } \textit{rate of change} \\ \text{of the energy} \\ \text{contained within} \\ \text{the system } \textit{at} \\ \textit{time } t \end{array} \right] = \left[\begin{array}{l} \text{net } \textit{rate} \text{ at which} \\ \text{energy is being} \\ \text{transferred in} \\ \text{by heat transfer} \\ \textit{at time } t \end{array} \right] - \left[\begin{array}{l} \text{net } \textit{rate} \text{ at which} \\ \text{energy is being} \\ \text{transferred out} \\ \text{by work } \textit{at} \\ \textit{time } t \end{array} \right]$$

Modeling Expansion and Compression Work

▶ A case having many practical applications is a gas (or liquid) undergoing an **expansion** (or **compression**) process while confined in a piston-cylinder assembly.

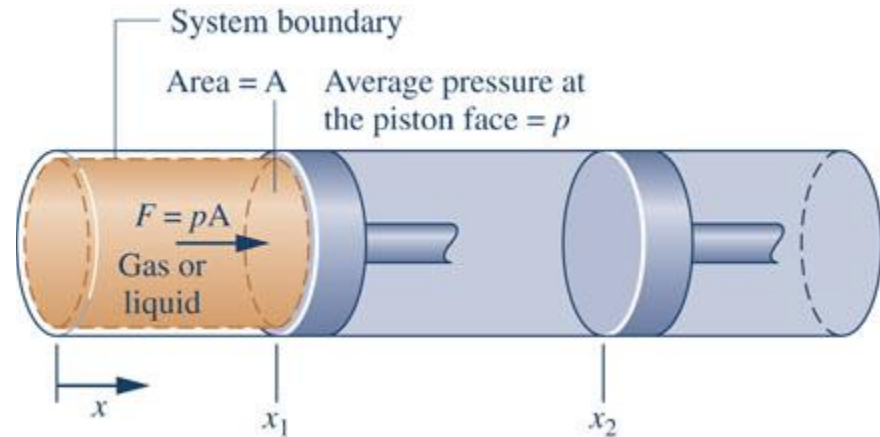

▶ During the process, the gas exerts a normal force on the piston, $F = pA$, where p is the pressure at the interface between the gas and piston and A is the area of the piston face.

Modeling Expansion and Compression Work

▶ From mechanics, the work done by the gas as the piston face moves from x_1 to x_2 is given by

$$W = \int F dx = \int p A dx$$

▶ Since the product $A dx = dV$, where V is the volume of the gas, this becomes

$$W = \int_{V_1}^{V_2} p dV$$

(Eq. 2.17)

▶ For a **compression**, dV is **negative** and so is the value of the integral, in keeping with the sign convention for work.

Modeling Expansion and Compression Work

- ▶ To perform the integral of **Eq. 2.17** requires a relationship between gas pressure at the interface between the gas and piston and the total gas volume.
- ▶ During an actual expansion of a gas such a relationship may be difficult, or even impossible, to obtain owing to non-equilibrium effects during the process – for example, effects related to combustion in the cylinder of an automobile engine.
- ▶ In most such applications, the work value can be obtained only by experiment.

Modeling Expansion and Compression Work

▶ **Eq. 2.17** can be applied to evaluate the work of **idealized processes** during which the pressure p in the integrand is the pressure of the entire quantity of the gas undergoing the process and not only the pressure at the piston face.

▶ For this we imagine the gas undergoes a sequence of equilibrium states during the process. Such an idealized expansion (or compression) is called a ***quasiequilibrium*** process.

Modeling Expansion and Compression Work

► In a quasiequilibrium expansion, the gas moves along a **pressure-volume curve**, or path, as shown.

► Applying **Eq. 2.17**, the **work done by the gas** on the piston is given by the **area under the curve of pressure versus volume**.

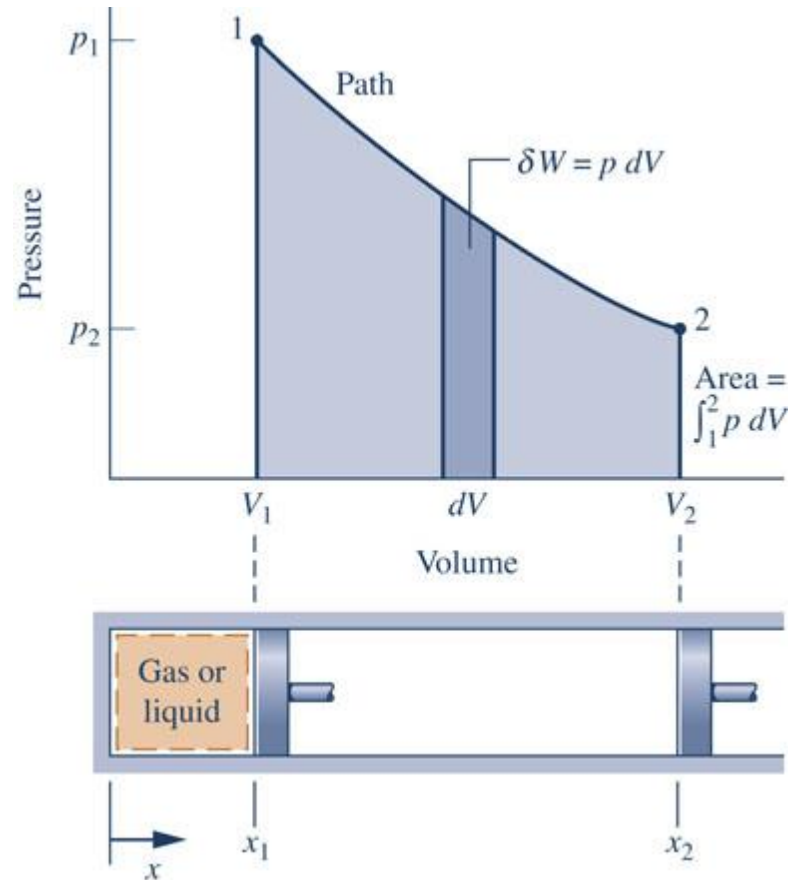

Modeling Expansion and Compression Work

▶ When the pressure-volume relation required by **Eq. 2.17** to evaluate work in a quasiequilibrium expansion (or compression) is expressed as an equation, the evaluation of expansion or compression work can be simplified.

▶ An example is a quasiequilibrium process described by $pV^n = \text{constant}$, where n is a constant. This is called a *polytropic process*.

▶ For the case $n = 1$, $pV = \text{constant}$ and **Eq. 2.17** gives

$$W = (\text{constant}) \ln\left(\frac{V_2}{V_1}\right)$$

where $\text{constant} = p_1V_1 = p_2V_2$.

Modeling Expansion and Compression Work

▶ Since non-equilibrium effects are invariably present during actual expansions (and compressions), the work determined with quasiequilibrium modeling can at best approximate the actual work of an expansion (or compression) between given end states.

Modes of Heat Transfer

▶ For any particular application, **energy transfer by heat** can occur by one or more of three **modes**:

▶ conduction

▶ radiation

▶ convection

Conduction

▶ **Conduction** is the transfer of energy from more energetic particles of a substance to less energetic adjacent particles due to interactions between them.

▶ The time rate of energy transfer by conduction is quantified by *Fourier's law*.

▶ An application of Fourier's law to a plane wall at steady state is shown at right.

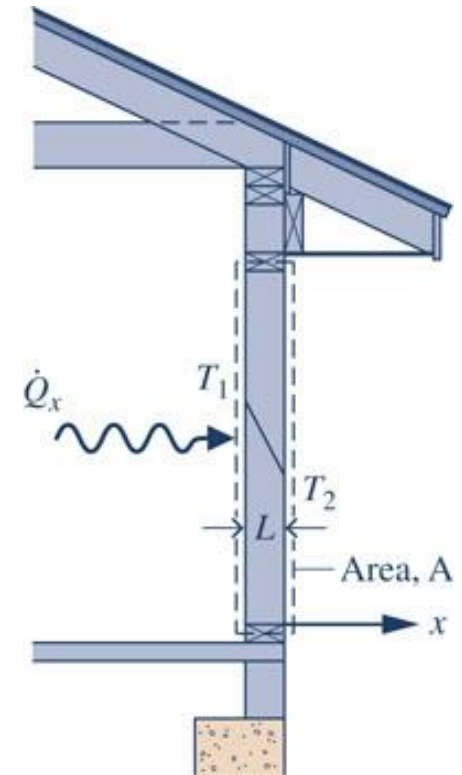

Conduction

► By **Fourier's law**, the rate of heat transfer across any plane normal to the x direction, \dot{Q}_x , is proportional to the wall area, A , and the temperature gradient in the x direction, dT/dx ,

$$\dot{Q}_x = -\kappa A \frac{dT}{dx} \quad \text{(Eq. 2.31)}$$

where

► κ is a proportionality constant, a property of the wall material called the **thermal conductivity**.

► The **minus sign** is a consequence of energy transfer in the direction of decreasing temperature.

► In this case, temperature varies linearly with x , and thus

$$\frac{dT}{dx} = \frac{T_2 - T_1}{L} (< 0) \quad \text{and} \quad \text{Eq. 2.31} \quad \text{gives} \quad \dot{Q}_x = -\kappa A \left[\frac{T_2 - T_1}{L} \right]$$

Thermal Radiation

- ▶ **Thermal radiation** is energy transported by electromagnetic waves (or photons). Unlike conduction, thermal radiation requires no intervening medium and can take place in a vacuum.
- ▶ The time rate of energy transfer by radiation is quantified by expressions developed from the *Stefan-Boltzman law*.

Thermal Radiation

▶ An application involving net radiation exchange between a surface at temperature T_b and a much larger surface at T_s ($< T_b$) is shown at right.

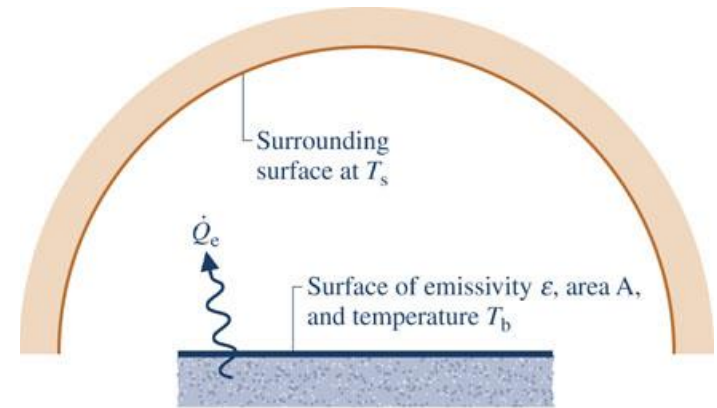

▶ Net energy is transferred in the direction of the arrow and quantified by

$$\dot{Q}_e = \epsilon\sigma A[T_b^4 - T_s^4] \quad \text{(Eq. 2.33)}$$

where

- ▶ A is the **area** of the smaller surface,
- ▶ ϵ is a property of the surface called its **emissivity**,
- ▶ σ is the **Stefan-Boltzman constant**.

Convection

- ▶ **Convection** is energy transfer between a solid surface and an adjacent gas or liquid by the combined effects of conduction and bulk flow within the gas or liquid.
- ▶ The rate of energy transfer by convection is quantified by *Newton's law of cooling*.

Convection

▶ An application involving energy transfer by convection from a transistor to air passing over it is shown at right.

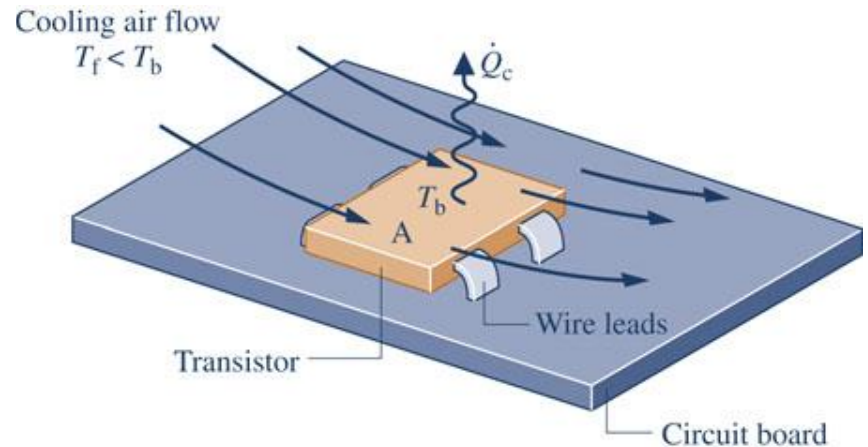

▶ Energy is transferred in the direction of the arrow and quantified by

$$\dot{Q}_c = hA[T_b - T_f] \quad \text{(Eq. 2.34)}$$

where

▶ A is the **area** of the transistor's surface and

▶ h is an empirical parameter called the **convection heat transfer coefficient**.

Thermodynamic Cycles

- ▶ A *thermodynamic cycle* is a sequence of processes that begins and ends at the same state.
- ▶ Examples of thermodynamic cycles include
 - ▶ **Power cycles** that **develop a net energy transfer by work** in the form of electricity using an energy input by heat transfer from hot combustion gases.
 - ▶ **Refrigeration cycles** that **provide cooling** for a refrigerated space using an energy input by work in the form of electricity.
 - ▶ **Heat pump cycles** that **provide heating** to a dwelling using an energy input by work in the form of electricity.

Power Cycle

- ▶ A system undergoing a power cycle is shown at right.
- ▶ The energy transfers by **heat and work** shown on the figure are each **positive in the direction of the accompanying arrow**. This convention is commonly used for analysis of thermodynamic cycles.

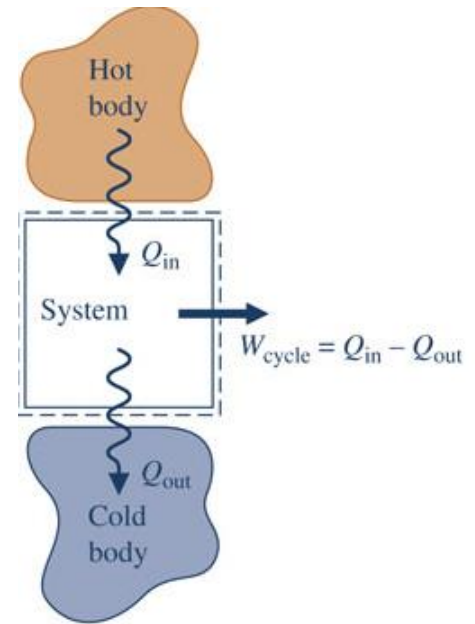

- ▶ W_{cycle} is the **net energy transfer by work** from the system per cycle of operation – in the form of electricity, typically.
- ▶ Q_{in} is the **heat transfer of energy to the system** per cycle from the hot body – drawn from hot gases of combustion or solar radiation, for instance.
- ▶ Q_{out} is the **heat transfer of energy from the system** per cycle to the cold body – discharged to the surrounding atmosphere or nearby lake or river, for example.

Power Cycle

▶ Applying the closed system energy balance to each cycle of operation,

$$\Delta E_{\text{cycle}} = Q_{\text{cycle}} - W_{\text{cycle}} \quad (\text{Eq. 2.39})$$

▶ Since the **system returns to its initial state after each cycle**, there is no net change in its energy: $\Delta E_{\text{cycle}} = 0$, and the energy balance reduces to give

$$W_{\text{cycle}} = Q_{\text{in}} - Q_{\text{out}} \quad (\text{Eq. 2.41})$$

▶ In words, the **net energy transfer by work from the system** equals the **net energy transfer by heat to the system**, each per cycle of operation.

Power Cycle

► The performance of a system undergoing a power cycle is evaluated on an energy basis in terms of the extent to which the energy added by heat, Q_{in} , is converted to a net work output, W_{cycle} . This is represented by the ratio

$$\eta = \frac{W_{cycle}}{Q_{in}} \quad (\text{power cycle}) \quad (\text{Eq. 2.42})$$

called the thermal efficiency.

► Introducing Eq. 2.41, an alternative form is obtained

$$\eta = \frac{Q_{in} - Q_{out}}{Q_{in}} = 1 - \frac{Q_{out}}{Q_{in}} \quad (\text{power cycle}) \quad (\text{Eq. 2.43})$$

Power Cycle

► Using the second law of thermodynamics (Chapter 5), we will show that the value of thermal efficiency must be less than unity: $\eta < 1$ ($< 100\%$). That is, **only a portion of the energy added by heat, Q_{in} , can be obtained as work.** The remainder, Q_{out} , is discharged.

Example: A system undergoes a power cycle while receiving 1000 kJ by heat transfer from hot combustion gases at a temperature of 500 K and discharging 600 kJ by heat transfer to the atmosphere at 300 K. Taking the combustion gases and atmosphere as the hot and cold bodies, respectively, determine for the cycle, the net work developed, in kJ, and the thermal efficiency.

► Substituting into **Eq. 2.41**, $W_{cycle} = 1000 \text{ kJ} - 600 \text{ kJ} = \underline{400 \text{ kJ}}$.

► Then, with **Eq. 2.42**, $\eta = 400 \text{ kJ}/1000 \text{ kJ} = \underline{0.4 (40\%)}$. Note the thermal efficiency is commonly reported on a percent basis.

Refrigeration Cycle

▶ A system undergoing a refrigeration cycle is shown at right.

▶ As before, the **energy transfers are each positive in the direction of the accompanying arrow.**

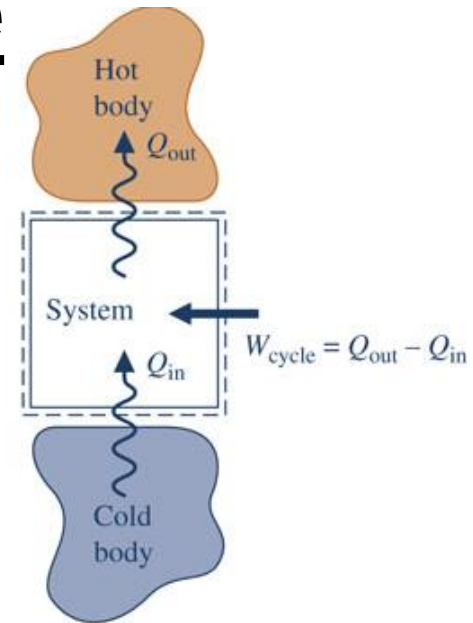

▶ W_{cycle} is the **net energy transfer by work** to the system per cycle of operation, usually in the form of electricity.

▶ Q_{in} is the **heat transfer of energy to the system** per cycle from the cold body – drawn from a freezer compartment, for example.

▶ Q_{out} is the **heat transfer of energy from the system** per cycle to the hot body – discharged to the space surrounding the refrigerator, for instance.

Refrigeration Cycle

▶ Since the **system returns to its initial state after each cycle**, there is no net change in its energy: $\Delta E_{\text{cycle}} = 0$, and the energy balance reduces to give

$$W_{\text{cycle}} = Q_{\text{out}} - Q_{\text{in}} \quad (\text{Eq. 2.44})$$

▶ In words, the **net energy transfer by work to the system** equals the **net energy transfer by heat from the system**, each per cycle of operation.

Refrigeration Cycle

► The performance of a system undergoing a refrigeration cycle is evaluated on an energy basis as the ratio of energy drawn from the cold body, Q_{in} , to the net work required to accomplish this effect, W_{cycle} :

$$\beta = \frac{Q_{in}}{W_{cycle}} \quad (\text{refrigeration cycle}) \quad (\text{Eq. 2.45})$$

called the coefficient of performance for the refrigeration cycle.

► Introducing Eq. 2.44, an alternative form is obtained

$$\beta = \frac{Q_{in}}{Q_{out} - Q_{in}} \quad (\text{refrigeration cycle}) \quad (\text{Eq. 2.46})$$

Heat Pump Cycle

▶ The **heat pump cycle analysis** closely parallels that given for the refrigeration cycle. The same figure applies:

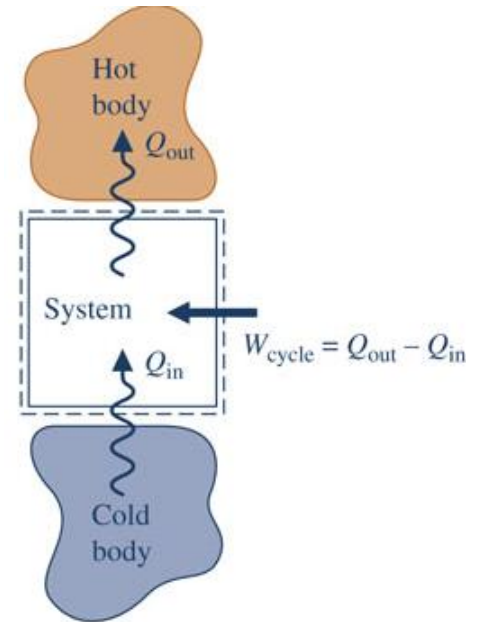

▶ But now the focus is on Q_{out} , which is the **heat transfer of energy from the system** per cycle to the hot body – such as to the living space of a dwelling.

▶ Q_{in} is the **heat transfer of energy to the system** per cycle from the cold body – drawn from the surrounding atmosphere or the ground, for example.

Heat Pump Cycle

▶ As before, W_{cycle} is the **net energy transfer by work** to the system per cycle, usually provided in the form of electricity.

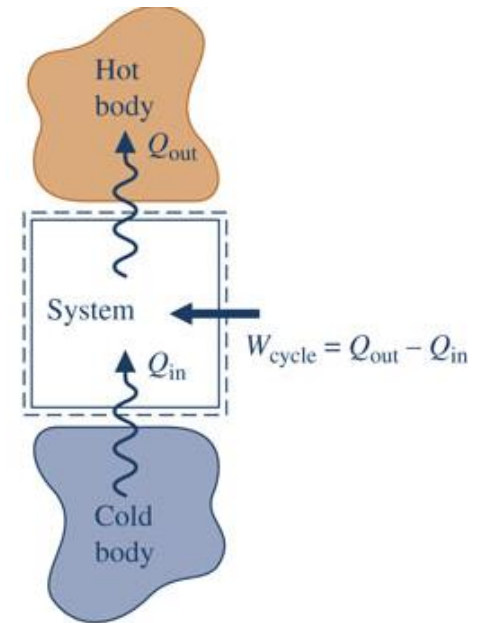

▶ As for the refrigeration cycle, the energy balance reads

$$W_{\text{cycle}} = Q_{\text{out}} - Q_{\text{in}}$$

(Eq. 2.44)

Heat Pump Cycle

► The performance of a system undergoing a heat pump cycle is evaluated on an energy basis as the ratio of energy provided to the hot body, Q_{out} , to the net work required to accomplish this effect, W_{cycle} :

$$\gamma = \frac{Q_{\text{out}}}{W_{\text{cycle}}} \quad (\text{heat pump cycle}) \quad (\text{Eq. 2.47})$$

called the coefficient of performance for the heat pump cycle.

► Introducing Eq. 2.44, an alternative form is obtained

$$\gamma = \frac{Q_{\text{out}}}{Q_{\text{out}} - Q_{\text{in}}} \quad (\text{heat pump cycle}) \quad (\text{Eq. 2.48})$$

Heat Pump Cycle

Example: A system undergoes a heat pump cycle while discharging 900 kJ by heat transfer to a dwelling at 20°C and receiving 600 kJ by heat transfer from the outside air at 5°C. Taking the dwelling and outside air as the hot and cold bodies, respectively, determine for the cycle, the net work input, in kJ, and the coefficient of performance.

▶ Substituting into **Eq. 2.44**, $W_{\text{cycle}} = 900 \text{ kJ} - 600 \text{ kJ} = \underline{300 \text{ kJ}}$.

▶ Then, with **Eq. 2.47**, $\gamma = 900 \text{ kJ} / 300 \text{ kJ} = \underline{3.0}$. Note the coefficient of performance is reported as its numerical value, as calculated here.