



COURSE: CEG2136/CEG2536
Computer Architecture I

Practice Problems 1

Logic Circuits

Q1. Design of a vending machine

Design and draw the logical diagram of a vending machine for pop drinks. Each can cost 15 cents. Only coins of 5 cents and of 10 cents are accepted. The circuit has two inputs X_1X_0 , and two outputs Y_1Y_0 . The behaviour of the circuit is described below:

X_1X_0 Description

- 0 0 No money is deposited in the machine
- 0 1 1 nickel is deposited in the machine
- 1 0 1 dime is deposited in the machine

- $Y_1 = 1 \Rightarrow$ Dispense a can
- $Y_0 = 1 \Rightarrow$ Give change a nickel

1. Assuming that the machine starts from state 00, complete the state diagram of the sequential circuit given in the following figure:

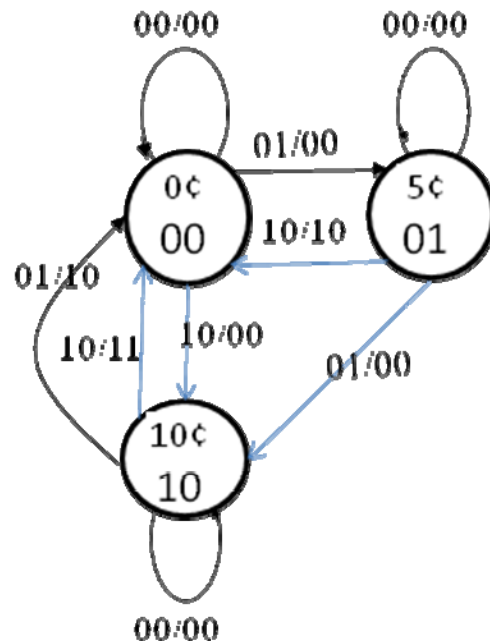
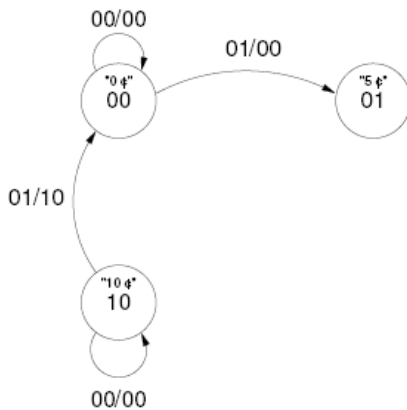

2. Derive the state table and then the excitation table, given that JK flip-flops are used for the state register of this sequential circuit.

Present State S^n		In		S^{n+1}		Out		Q_1 in		Q_0 in	
Q_1	Q_0	X_1	X_0	Q_1^+	Q_0^+	Y_1	Y_0	J_1	K_1	J_0	K_0
0	0	0	0	0	0	0	0	0	x	0	x
0	0	0	1	0	1	0	0	0	x	1	x
0	0	1	0	1	0	0	0	1	x	0	x
0	0	1	1	x	x	x	x	x	x	x	x
0	1	0	0	0	1	0	0	0	x	x	0
0	1	0	1	1	0	0	0	1	x	x	1
0	1	1	0	0	0	1	0	0	x	x	1
0	1	1	1	x	x	x	x	x	x	x	x
1	0	0	0	1	0	0	0	x	0	0	x
1	0	0	1	0	0	1	0	x	1	0	x
1	0	1	0	0	0	1	1	x	1	0	x
1	0	1	1	x	x	x	x	x	x	x	x
1	1	0	0	x	x	x	x	x	x	x	x
1	1	0	1	x	x	x	x	x	x	x	x
1	1	1	0	x	x	x	x	x	x	x	x
1	1	1	1	x	x	x	x	x	x	x	x

3. Derive the simplified excitation equations of the JK flip-flops and the output equations.

One can find $J_1, K_1, J_0, K_0,$

a) directly from the above excitation table,
or

b) do the transition table

Next state S^{n+1} / Output = $Q_1^+ Q_0^+ / Y_1 Y_0$

$Q_1 Q_0$ \ $X_1 X_0$	0 0	0 1	1 1	1 0
00	0 0 0 0 x x 1 0 0 0	0 1 0 0 x x 0 0 1 0	1 1 x x x x x x x x	1 0 1 0 0 0 1 0 1 1
01	0 0 0 0 x x 0 0 1 0	0 1 0 0 x x 0 0 1 0	1 1 x x x x x x x x	1 0 1 0 0 0 1 0 1 1
11	x x x x x x x x x x	0 1 0 0 x x 0 0 1 0	1 1 x x x x x x x x	1 0 1 0 0 0 1 0 1 1
10	1 0 0 0 0 0 1 0 x x	0 1 0 0 x x 0 0 1 0	1 1 x x x x x x x x	1 0 1 0 0 0 1 0 1 1

and then find the transition and output functions as shown next.

Find first the transition function for $Q_1^+ = \delta(Q_1, Q_0, X_1, X_0)$ to obtain J & K by mapping it to the JKFF characteristic function $Q^{n+1} = Q^n \cdot J^n + Q^n \cdot K^n$

Q_1^+ \ $X_1 X_0$	00	01	11	10
$Q_1 Q_0$				
00	0	0	x	1
01	0	1	x	0
11	x	x	x	x
10	1	0	x	0

$$Q_1^+ = Q_0 X_0 + Q_1' Q_0' X_1 = Q_0(Q_1 + Q_1') X_0 + Q_1' Q_0' X_1 = Q_0(Q_1) X_0 + Q_0(Q_1') X_0 + Q_1' Q_0' X_1 =$$

$$Q_1^+ = Q_1' (Q_0 X_0 + Q_0' X_1) + Q_1 X_0 Q_0 =$$

$$Q_1^+ = Q_1' J_1 + Q_1 K_1 \text{ (JKFF char. equation)}$$

$$\rightarrow J_1 = Q_0 X_0 + Q_0' X_1; \quad K_1 = X_0 Q_0$$

Q_0^+ \ $X_1 X_0$	00	01	11	10
$Q_1 Q_0$				
00	0	1	x	0
01	1	0	x	0
11	x	x	x	x
10	0	0	x	0

$$Q_0^+ = Q_1' Q_0' X_0$$

$$\rightarrow J_0 = \dots \quad K_0 = \dots$$

Y_1 \ $X_1 X_0$	00	01	11	10
$Q_1 Q_0$				
00	0	0	x	0
01	0	0	x	1
11	x	x	x	x
10	0	1	x	1

$$Y_1 = Q_0 X_0 + Q_0 X_1 + Q_1 X_0 + Q_1 X_1$$

Y_0 \ $X_1 X_0$	00	01	11	10
$Q_1 Q_0$				
00	0	0	x	0
01	0	0	x	0
11	x	x	x	x
10	0	0	x	1

$$Y_0 = Q_1 X_1$$

4. Draw the logic diagram of the circuit, using only NAND gates and JK flip flops...

Q2. Conceive a 3-bit multifunction register that can perform the following operations:
Use T-type flip flops and any logic gates or other combinational digital circuits.

Top-down design:

c1	c0	Function
0	0	f ⁰ : Store (preserve) register's content
0	1	f ¹ : Right shift (register's <i>serial input</i> is connected to an external input <i>I</i>)
1	0	f ² : Increment by 1
1	1	f ³ : Swap the most significant bit (msb) with the least significant bit (lsb)

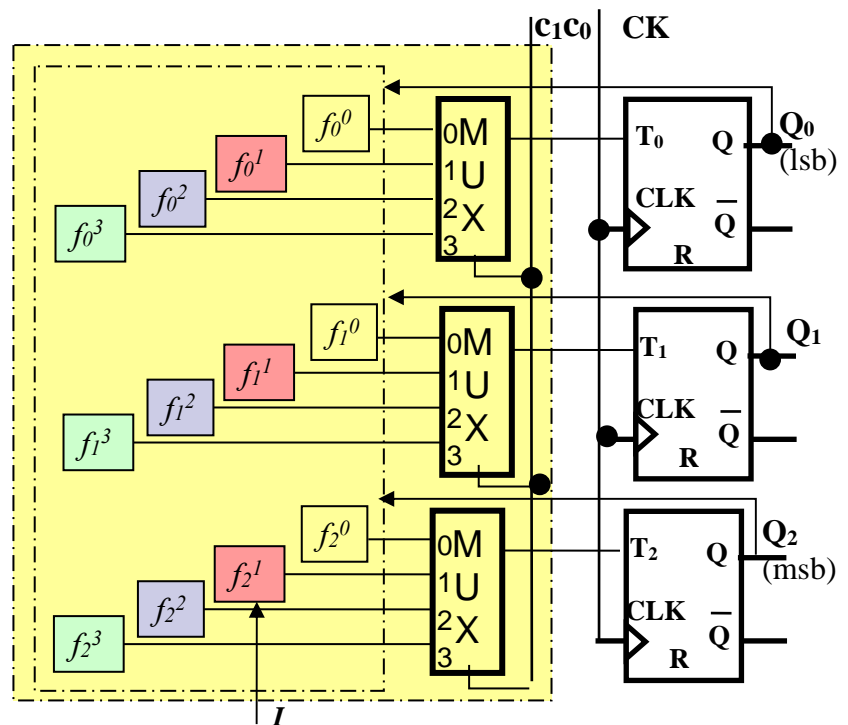

c1	c0	Function	Transition Equations (preliminary steps)	Excitation Equations T_i (final results - derived for each case separately, as shown after this table)
0	0	f ⁰ : Store (preserve) register's content	$Q_i(n+1) = Q_i(n) ; i = \{0,1,2\}$	$T_i = 0 ; i = \{0,1,2\}$
0	1	f ¹ : Right shift (register's <i>serial input</i> is connected to an external input <i>I</i>)	$Q_i(n+1) = Q_{i+1}(n) ; i=0,1$ $Q_2(n+1) = I(n)$	if $Q_i(n) = Q_{i+1}(n) \Rightarrow T_i = 0 ;$ if $Q_i(n) \neq Q_{i+1}(n) \Rightarrow T_i = 1 ;$ i.e., $T_i = Q_i \oplus Q_{i+1}, i = 0,1$ $T_2 = Q_2 \oplus I$
1	0	f ² : Increment by 1	$[Q_2 Q_1 Q_0](n+1) = [Q_2 Q_1 Q_0](n) + 1$	$T_2 = Q_1 \cdot Q_0 ; T_1 = Q_0 ; T_0 = 1$
1	1	f ³ : Swap the most significant bit (msb) with the least significant bit (lsb)	$Q_0(n+1) = Q_2(n)$ $Q_1(n+1) = Q_1(n)$ $Q_2(n+1) = Q_0(n)$	$T_2 = T_0 = \overline{Q_2} \cdot Q_0 + Q_2 \cdot \overline{Q_0} = Q_2 \oplus Q_0$ $T_1 = 0$

$c_1c_0 = 01$: Transition equation to implement: $Q_i(n+1) = Q_{i+1}(n)$; $i=1,2$

Input of Q_i	Present state of Q_i	Next state of Q_i	
$Q_{i+1}(n)$	$Q_i(n)$	$Q_i(n+1)$	T_i
0	0	0	0
0	1	0	1
1	0	1	1
1	1	1	0

$$T_i = Q_i \oplus Q_{i+1}; i = 1,2$$

$$T_2 = Q_2 \oplus I$$

$c_1c_0 = 10$: $[Q_2 Q_1 Q_0](n+1) = [Q_2 Q_1 Q_0](n) + 1$

Present State			Next State					
$Q_2(n)$	$Q_1(n)$	$Q_0(n)$	$Q_2(n+1)$	$Q_1(n+1)$	$Q_0(n+1)$	T_2	T_1	T_0
0	0	0	0	0	1	0	0	1
0	0	1	0	1	0	0	1	1
0	1	0	0	1	1	0	0	1
0	1	1	1	0	0	1	1	1
1	0	0	1	0	1	0	0	1
1	0	1	1	1	0	0	1	1
1	1	0	1	1	1	0	0	1
1	1	1	0	0	0	1	1	1

$$T_2 = Q_1 \cdot Q_0$$

$$T_1 = Q_0$$

$$T_0 = 1$$

$c_1c_0 = 11$:
 $Q_0(n+1) = Q_2(n)$
 $Q_1(n+1) = Q_1(n)$
 $Q_2(n+1) = Q_0(n)$

Present State			Next State					
$Q_2(n)$	$Q_1(n)$	$Q_0(n)$	$Q_2(n+1)$	$Q_1(n+1)$	$Q_0(n+1)$	T_2	T_1	T_0
0	0	0	0	0	0	0	0	0
0	0	1	1	0	0	1	0	1
0	1	0	0	1	0	0	0	0
0	1	1	1	1	0	1	0	1
1	0	0	0	0	1	1	0	1
1	0	1	1	0	1	0	0	0
1	1	0	0	1	1	1	0	1
1	1	1	1	1	1	0	0	0

$T_2 = T_0$

	$Q_1 Q_0$	00	01	11	10
Q_2	0	0	1	1	0
	1	1	0	0	1

$$T_2 = T_0 = \overline{Q_2} \cdot Q_0 + Q_2 \cdot \overline{Q_0}$$

$$= Q_2 \oplus Q_0$$

$$T_1 = 0$$

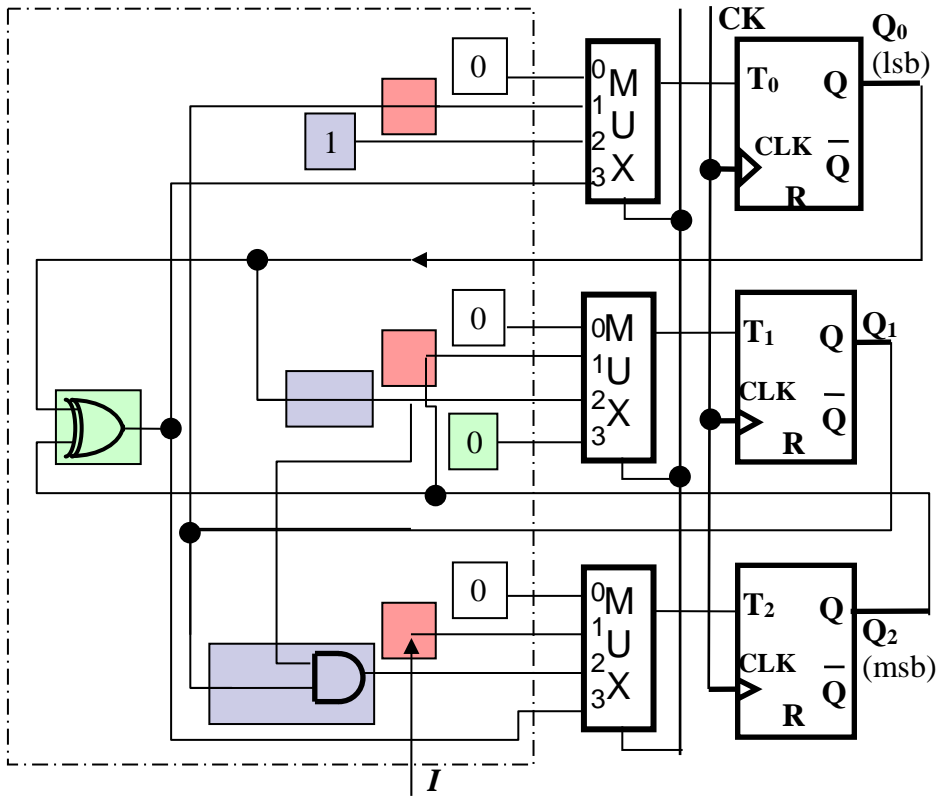

Q3. Implement $f(A,B,C,D) = \Sigma(1,4,5,7,9,12,13)$ using a MUX(8x1) where $A, C,$ and D are connected to the multiplexor's select inputs.

	A	B	C	D	f
0	0	0	0	0	0
1	0	0	0	1	1
2	0	0	1	0	0
3	0	0	1	1	0
4	0	1	0	0	1
5	0	1	0	1	1
6	0	1	1	0	0
7	0	1	1	1	1
8	1	0	0	0	0
9	1	0	0	1	1
10	1	0	1	0	0
11	1	0	1	1	0
12	1	1	0	0	1
13	1	1	0	1	1
14	1	1	1	0	0
15	1	1	1	1	0

	A	C	D	B	f	
0	0	0	0	0	0	B
1	0	0	0	1	1	
2	0	1	0	0	0	
3	0	1	1	0	0	B
4	1	0	0	0	0	B
5	1	0	0	1	1	
6	1	1	0	0	0	
7	1	1	1	0	0	0

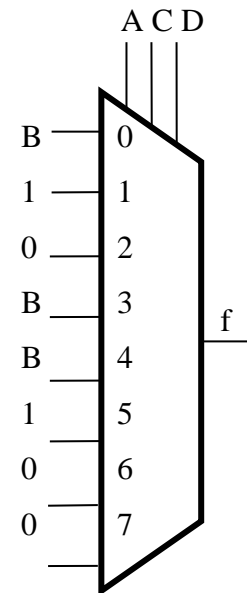

Q4. The figure below represents an intersection of two streets. Sensors have been placed in the proximity of the intersection, along A, B, C and D lanes to detect vehicles' presence. A sensor's output is **1** when there is no vehicle on its monitored lane (indicated as *free* in the following) and **0** when a vehicle is present (*busy* lane). The two sets of intersection lights (East-West or *EW*, and North-South or *NS*) observe the following logic:

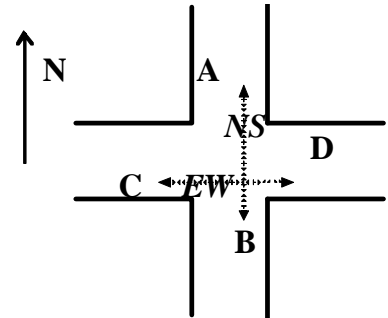

- 1) The *EW* lights will turn green when vehicles will be simultaneously detected on both C and D lanes.
- 2) The *EW* lights will also be green when either C is *busy* or D is *busy*, and, if A and B are not both *busy* at the same time.
- 3) The *NS* lights will be green when vehicles will be sensed on both A and B lanes, and, if C and D are not simultaneously *busy*.
- 4) The *NS* lights will also turn green when either A is *busy* or B is *busy*, but C and D are both *free*.
- 5) The *EW* lights will also be green when no vehicle is present in the intersection.

a) Using sensors A, B, C, D as input variables, implement a logical combinational circuit that controls the lights. There will be 2 output functions $NS(A,B,C,D)$ and $EW(A,B,C,D)$ whose values will be 1 when the light is green (and 0 for the red!). Simplify the 2 functions and derive their Sum-of-Products minimal form (no logic diagram asked).

NOTE: The Oxford English Dictionary explains “either ... or” as follows:

The primary function of either, etc., is to emphasize the indifference of the two (or more) things or courses ... but a secondary function is to emphasize the mutual exclusiveness, = either of the two, but not both.

1)	The <i>EW</i> lights will turn green when vehicles will be simultaneously detected on both C and D lanes.	$EW_1 = C'D'$
2)	The <i>EW</i> lights will also be green when either C is <i>busy</i> or D is <i>busy</i> , and, if A and B are not both <i>busy</i> at the same time.	$EW_2 = (C' \text{ xor } D') (A'B)'$
3)	The <i>NS</i> lights will be green when vehicles will be sensed on both A and B lanes, and, if C and D are not simultaneously <i>busy</i> .	$NS_1 = A'B' . (C'D)'$
4)	The <i>NS</i> lights will also turn green when either A is <i>busy</i> or B is <i>busy</i> , but C and D are both <i>free</i> .	$NS_2 = (A' \text{ xor } B') . (CD)$
5)	The <i>EW</i> lights will also be green when no vehicle is present in the intersection.	$EW_3 = ABCD$

EW

CD	00	01	11	10
AB				
00	1)	⇒		⇒
01	1)	2)		2)
11	1)	2)	5)	2)
10	1)	2)		2)

NS

CD	00	01	11	10
AB				
00	⇒	3)	3)	3)
01	⇒	⇒	4)	⇒
11				
10	⇒	⇒	4)	⇒

EW

CD	00	01	11	10
AB				
00	1			
01	1	1		1
11	1	1	1	1
10	1	1		1

NS

CD	00	01	11	10
AB				
00		1	1	1
01			1	
11				
10			1	

Condition:					1)				2)	3)	4)	5)		
	A	B	C	D	EW ₁	C' xor D'	(A'B')	EW ₂	NS ₁	NS ₂	EW ₃	EW	NS	
0	0	0	0	0	1							1		
1	0	0	0	1		1			1				1	
2	0	0	1	0		1			1				1	
3	0	0	1	1					1				1	
4	0	1	0	0	1		1					1		
5	0	1	0	1		1	1	1				1		
6	0	1	1	0		1	1	1				1		
7	0	1	1	1			1			1			1	
8	1	0	0	0	1		1					1		
9	1	0	0	1		1	1	1				1		
10	1	0	1	0		1	1	1				1		
11	1	0	1	1			1			1			1	
12	1	1	0	0	1		1					1		
13	1	1	0	1		1	1	1				1		
14	1	1	1	0		1	1	1				1		
15	1	1	1	1			1				1	1		

b) Realize NS(A,B,C,D) and EW(A,B,C,D) using a 4-to-16 decoder and 2 OR gates; draw the circuit diagram.

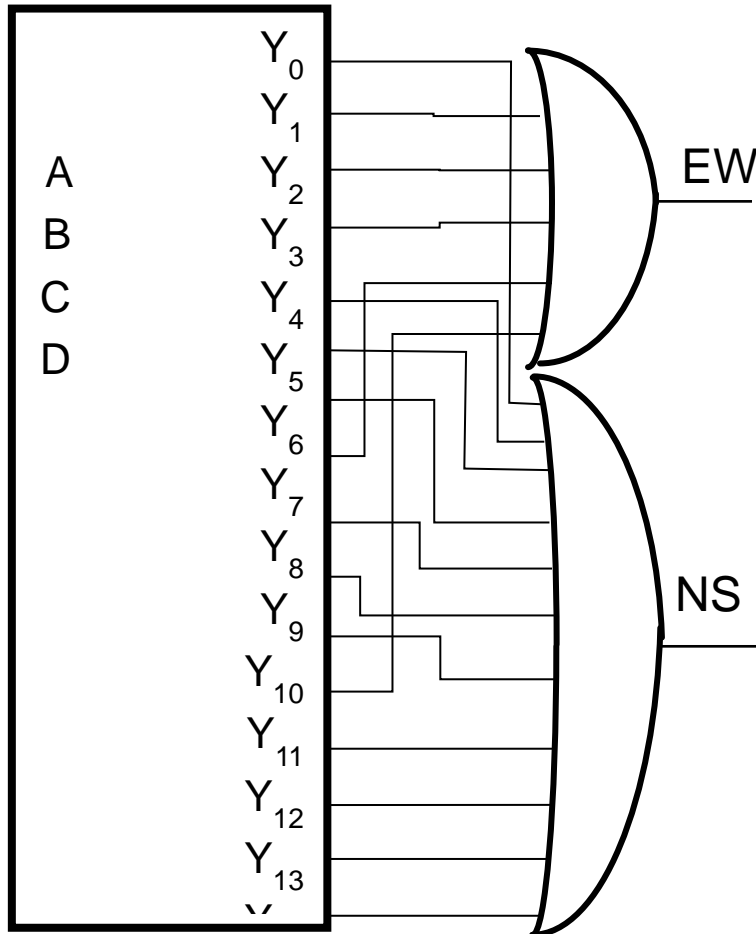

Q5. A sequential circuit has two JK flip-flops A and B, one input X and one output Z. The circuit logic diagram is shown below. Derive the circuit State Table as well as the State diagram.

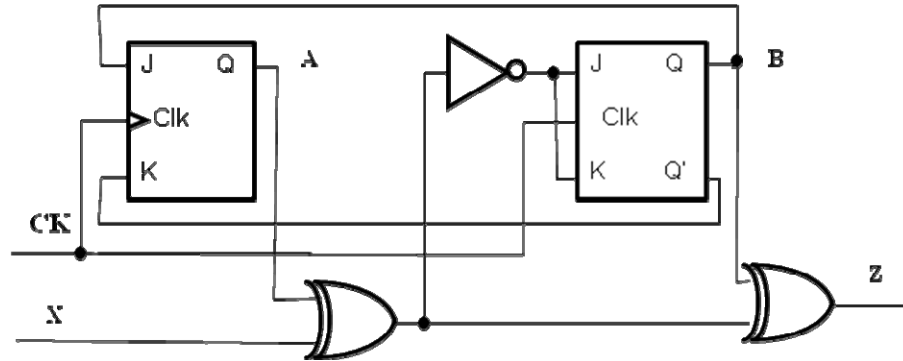

$$JA = B, KA = B',$$

$$JB = KB = (A \oplus X)' = AX + A'X',$$

$$Y = (A \oplus X) \oplus B$$

A_{t+1} and B_{t+1} can be derived using the JK characteristic equation ($Q^{t+1} = \overline{Q}^t \cdot J^t + Q^t \cdot \overline{K}^t$).
 Ex., $A_{t+1} = A_t K A' + A_t' J A = A_t (B')' + A_t' (B) = A_t (B) + A_t' (B) = (A_t + A_t') B = B$

You can also use the characteristic table instead of the characteristic equation:

J	K	Q_{t+1}
0	0	Q_t
0	1	0
1	0	1
1	1	Q_t'

A	B	X	JA	KA	A_{t+1}	JB	KB	B_{t+1}
0	0	0	0	1	0	1	1	1
0	0	1	0	1	0	0	0	0
0	1	0	1	0	1	1	1	0
0	1	1	1	0	1	0	0	1
1	0	0	0	1	0	0	0	0
1	0	1	0	1	0	1	1	1
1	1	0	1	0	1	0	0	1
1	1	1	1	0	1	1	1	0

State Table:

Present State		In	Next State		Out
A	B	X	A_{t+1}	B_{t+1}	Y
0	0	0	0	1	0
0	0	1	0	0	1
0	1	0	1	0	1
0	1	1	1	1	0
1	0	0	0	0	1
1	0	1	0	1	0
1	1	0	1	1	0
1	1	1	1	0	1

State Diagram

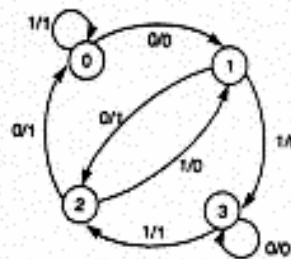

Q6. Using *D flip-flops*, design and implement (devise the logic diagram) the sequential circuit specified by the following state table:

Present State		In	Next State		Out
A	B		A_{t+1}	B_{t+1}	
0	0	0	0	0	0
0	0	1	0	1	0
0	1	0	0	0	0
0	1	1	1	1	0
1	0	0	0	0	0
1	0	1	0	1	1
1	1	0	1	0	0
1	1	1	1	1	0

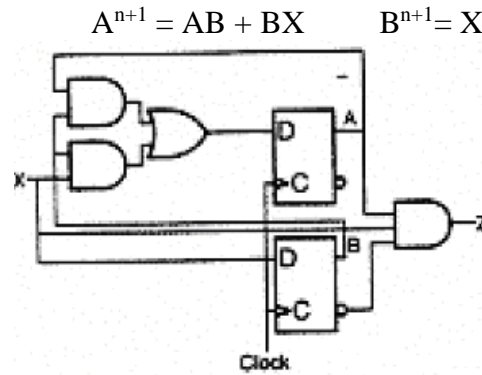

Q7. Using *JK flip-flops*, design and implement (devise the logic diagram) the sequential circuit specified by the following state table:

Present State		Input	Next State		FF's Inputs (Excitations)			
A	B		A	B	JA	KA	JB	KB
0	0	0	0	0	0	X	0	X
0	0	1	0	1	0	X	1	X
0	1	0	1	0	1	X	X	1
0	1	1	0	1	0	X	X	0
1	0	0	1	0	X	0	0	X
1	0	1	1	1	X	0	1	X
1	1	0	1	1	X	0	X	0
1	1	1	0	0	X	1	X	1

