

Table of Contents

Topic 1: Review of Vectors.....	4
1.1 Vectors in 3D Space: i, j, k Notation	4
1.2 Dot Product (a.k.a. Scalar Product, Euclidean Inner Product)	5
Definition.....	5
Properties of the Dot Product.....	5
1.3 Cross Product (a.k.a. Vector Product, Euclidean Inner Product).....	6
Definition.....	6
Properties of the Cross Product.....	6
Useful Rules.....	6
Topic 2: Electric Fields	7
2.1 Coulomb's Law.....	7
2.2 The Electric Field	9
2.3 The Electric Field of a Continuous Charge Distribution.....	11
2.4 Motion of a Charged Particle in an Electric Field.....	13
Topic 3: Gauss's Law.....	15
3.1 Electric Flux.....	15
3.2 Gauss's Law	15
3.3 Conductors in Electrostatic Equilibrium	15
Topic 3: Gauss's Law Sample Problems	16
Topic 4: Electric Potential.....	19
4.1 Potential Difference.....	19
4.2 Electric Potential Energy due to Point Charges	19
4.2 Electric Potential Energy due to a Continuous Charge Distribution	19
Topic 4: Electric Potential Sample Problems	20
Topic 5: Capacitors and Dielectrics.....	22
5.1 Capacitance.....	22
5.2 Combinations of Capacitors.....	22
5.3 Energy Stored in a Charged Capacitor.....	22
5.4 Capacitors with Dielectrics.....	22
5.5 Electric Dipole in an Electric Field	22
Topic 6: Current and Resistance	25
6.1 Electric Current and Resistance	25
6.1 Electrical Power.....	25
Topic 7: Direct Current Circuits	26
7.1 Resistors in Series and Parallel	26
7.1 Resistors in Series and Parallel	28
Kirchhoff's First Law - The Current Law, (KCL).....	28
Kirchhoff's Second Law - The Voltage Law, (KVL).....	28
Application of Kirchhoff's Circuit Laws.....	30
Topic 8: Magnetic Fields and Forces.....	33
8.1 Motion of a Charged Particle in a Uniform Magnetic Field	33
8.2 Magnetic Force Acting on a Current-Carrying Conductor	33
8.3 Torque on a Current Loop in a Uniform Magnetic Field.....	33
Topic 9: Sources of the Magnetic Field	35
9.1 The Biot-Savart Law	35
9.2 The Magnetic Force Between Two Parallel Conductors	35

Topic 10: Faraday's Law	36
10.1 Faraday's Law of Induction	36
10.2 Lenz's Law	36
Topic 11: Inductance	38
11.1 Self-Induction and Inductance	38
11.2 RL Circuits	38
Topic 12: Alternating Current Circuits	41

Topic 1: Review of Vectors

Reference: *Elementary Linear Algebra*, 9th ed. by Howard Anton and Chris Rorres

1.1 Vectors in 3D Space: i, j, k Notation

Vectors can be added and subtracted easily when they are broken down into their components. A vector $\mathbf{u} = (u_x, u_y, u_z)$ can be expressed in terms of its x , y , and z components:

$$\mathbf{u} = (u_x, u_y, u_z) = (u_x, 0, 0) + (0, u_y, 0) + (0, 0, u_z) = u_x(1, 0, 0) + u_y(0, 1, 0) + u_z(0, 0, 1)$$

\mathbf{i} , \mathbf{j} , and \mathbf{k} represent unit vectors in what are commonly known as the x , y , and z directions, respectively (Fig. 1.1)

They can be defined by:

$$\mathbf{i} = (1, 0, 0) \quad \mathbf{j} = (0, 1, 0) \quad \mathbf{k} = (0, 0, 1)$$

Using these definitions, a vector $\mathbf{u} = (u_x, u_y, u_z)$ can be expressed using \mathbf{i} , \mathbf{j} , \mathbf{k} notation:

$$\mathbf{u} = u_x(1, 0, 0) + u_y(0, 1, 0) + u_z(0, 0, 1) = u_x\mathbf{i} + u_y\mathbf{j} + u_z\mathbf{k}$$

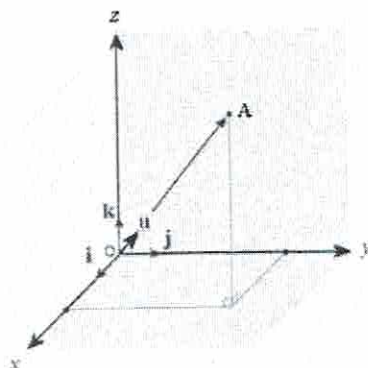

Figure 1.1 \mathbf{i} , \mathbf{j} , and \mathbf{k} represent unit vectors in the x , y , and z directions, respectively. (Diagram borrowed from <http://www.intmath.com/vectors/7-vectors-in-3d-space.php>)

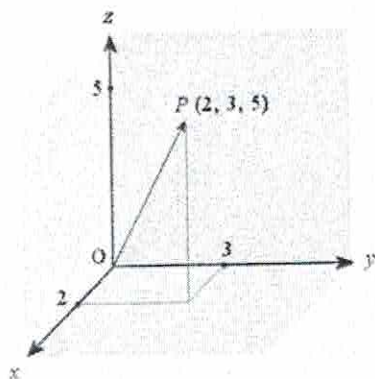

Figure 1.2 Vector \mathbf{OP}
(Diagram borrowed from <http://www.intmath.com/vectors/7-vectors-in-3d-space.php>)

Example 1.1:

In Figure 1.2, express vector \mathbf{OP} in \mathbf{i} , \mathbf{j} , \mathbf{k} notation.

Solution:

$$\mathbf{OP} = (OP_x, OP_y, OP_z) = (2, 3, 5) = 2\mathbf{i} + 3\mathbf{j} + 5\mathbf{k}$$

$$\mathbf{OP} = 2\mathbf{i} + 3\mathbf{j} + 5\mathbf{k}$$

1.2 Dot Product (a.k.a. Scalar Product, Euclidean Inner Product)

Definition

If \mathbf{u} and \mathbf{v} are vectors in 2D or 3D, and θ is the smaller angle between them, then the dot product $\mathbf{u} \cdot \mathbf{v}$ is defined by:

$$\begin{aligned} \mathbf{u} \cdot \mathbf{v} &= \|\mathbf{u}\| \|\mathbf{v}\| \cos\theta && \text{if } \mathbf{u} \neq \mathbf{0} \text{ and } \mathbf{v} \neq \mathbf{0} \\ \mathbf{u} \cdot \mathbf{v} &= 0 && \text{if } \mathbf{u} = \mathbf{0} \text{ or } \mathbf{v} = \mathbf{0} \end{aligned}$$

Where $\|\mathbf{u}\|$ represents the magnitude of the vector \mathbf{u} : $\|\mathbf{u}\| = \sqrt{u_x^2 + u_y^2 + u_z^2}$

Practically, the dot product can be calculated as follows:

$$\mathbf{u} \cdot \mathbf{v} = u_x v_x + u_y v_y + u_z v_z$$

Example 1.2

Consider the vectors $\mathbf{u} = (1, -3, 5)$ and $\mathbf{v} = (-2, -2, 1)$. Find $\mathbf{u} \cdot \mathbf{v}$ and determine the angle θ between them.

Solution:

$$\mathbf{u} \cdot \mathbf{v} = u_x v_x + u_y v_y + u_z v_z = (1)(-2) + (-3)(-2) + (5)(1) = 9$$

$$\|\mathbf{u}\| = \sqrt{1^2 + (-3)^2 + 5^2} = 5$$

$$\|\mathbf{v}\| = \sqrt{(-2)^2 + (-2)^2 + 1^2} = 3$$

$$\mathbf{u} \cdot \mathbf{v} = \|\mathbf{u}\| \|\mathbf{v}\| \cos\theta$$

$$\cos\theta = \frac{\mathbf{u} \cdot \mathbf{v}}{\|\mathbf{u}\| \|\mathbf{v}\|} = \frac{9}{(5)(3)} = \frac{3}{5}$$

Thus, $\theta = 53.1^\circ$.

Properties of the Dot Product

- $\mathbf{u} \cdot \mathbf{v} = \mathbf{v} \cdot \mathbf{u}$
- If a and b are numbers and $\mathbf{u}, \mathbf{v}, \mathbf{z}$ are vectors then $(a\mathbf{u} + b\mathbf{v}) \cdot \mathbf{z} = a(\mathbf{u} \cdot \mathbf{z}) + b(\mathbf{v} \cdot \mathbf{z})$
- $\mathbf{u} \cdot \mathbf{u} > 0$ if $\mathbf{u} \neq \mathbf{0}$; and $\mathbf{u} \cdot \mathbf{u} = 0$ if and only if $\mathbf{u} = \mathbf{0}$

1.3 Cross Product (a.k.a. Vector Product, Euclidean Inner Product)

Definition

If $\mathbf{u} = (u_x, u_y, u_z)$ and $\mathbf{v} = (v_x, v_y, v_z)$ are vectors in 3D, then the cross product $\mathbf{u} \times \mathbf{v}$ is defined by:

$$\mathbf{u} \times \mathbf{v} = (u_y v_z - u_z v_y, u_z v_x - u_x v_z, u_x v_y - u_y v_x)$$

An easier way to calculate the cross product is to use \mathbf{i} , \mathbf{j} , \mathbf{k} notation, and the 3x3 determinant:

$$\mathbf{u} \times \mathbf{v} = \begin{vmatrix} \mathbf{i} & \mathbf{j} & \mathbf{k} \\ u_x & u_y & u_z \\ v_x & v_y & v_z \end{vmatrix} = \begin{bmatrix} u_y & u_z \\ v_y & v_z \end{bmatrix} \mathbf{i} - \begin{bmatrix} u_x & u_z \\ v_x & v_z \end{bmatrix} \mathbf{j} + \begin{bmatrix} u_x & u_y \\ v_x & v_y \end{bmatrix} \mathbf{k}$$

Example 1.3

Consider the vectors $\mathbf{u} = (1, -3, 5)$ and $\mathbf{v} = (-2, -2, 1)$ again. Find $\mathbf{u} \times \mathbf{v}$.

Solution:

$$\begin{aligned} \mathbf{u} \times \mathbf{v} &= \begin{vmatrix} \mathbf{i} & \mathbf{j} & \mathbf{k} \\ 1 & -3 & 5 \\ -2 & -2 & 1 \end{vmatrix} = \begin{bmatrix} -3 & 5 \\ -2 & 1 \end{bmatrix} \mathbf{i} - \begin{bmatrix} 1 & 5 \\ -2 & 1 \end{bmatrix} \mathbf{j} + \begin{bmatrix} 1 & -3 \\ -2 & -2 \end{bmatrix} \mathbf{k} \\ &= [(-3)(1) - (5)(-2)]\mathbf{i} - [(1)(1) - (5)(-2)]\mathbf{j} + [(1)(-2) - 3(-2)]\mathbf{k} \\ &= 7\mathbf{i} - 11\mathbf{j} - 8\mathbf{k} \end{aligned}$$

Properties of the Cross Product

1. If $\mathbf{u} \times \mathbf{v} = 0$ then \mathbf{u} and \mathbf{v} are parallel vectors
2. 1. If $\mathbf{u} \times \mathbf{v} \neq 0$ then $\mathbf{u} \times \mathbf{v}$ is orthogonal to both \mathbf{u} and \mathbf{v}

Useful Rules

$$\mathbf{i} \cdot \mathbf{i} = \mathbf{j} \cdot \mathbf{j} = \mathbf{k} \cdot \mathbf{k} = 1$$

$$\mathbf{i} \cdot \mathbf{j} = \mathbf{j} \cdot \mathbf{k} = \mathbf{k} \cdot \mathbf{i} = 0$$

$$\mathbf{i} \times \mathbf{j} = \mathbf{k}$$

$$\mathbf{j} \times \mathbf{k} = \mathbf{i}$$

$$\mathbf{k} \times \mathbf{i} = \mathbf{j}$$

Topic 2: Electric Fields

(Reference: *Physics for Scientists and Engineers by Serway and Jewett, 7th ed., Chapter 23*)

2.1 Coulomb's Law

Two charges will exert forces on each other of equal magnitude and inversely proportional to the square of the distance between them, r . **Coulomb's law** gives the magnitude of electric force between two point charges:

$$F_e = k_e \frac{|q_1||q_2|}{r^2}$$

Where,

- F_e is the magnitude of the electric force between the two point charges,
- $k_e = 8.9876 \times 10^9 \text{ N} \cdot \text{m}^2/\text{C}^2$ is the Coulomb constant, and is also written $k_e = \frac{1}{4\pi\epsilon_0}$
- $\epsilon_0 = 8.8542 \times 10^{-12} \text{ C}^2/\text{N} \cdot \text{m}^2$ is the permittivity of free space
- q_1, q_2 are point charges with the unit of Coulombs, C
- r is the distance between the point charges

The smallest charge that exists in nature is the charge on an electron ($-e$) or proton ($+e$), with a magnitude of $e = 1.602 \times 10^{-19} \text{ C}$.

$$1 \text{ Coulomb of charge} = 6.24 \times 10^{18} \text{ electrons or protons of charge}$$

Example 2.1

Three point charges, q_1, q_2, q_3 , are positioned as shown in Figure 2.1. What is the electric force on q_1 ?

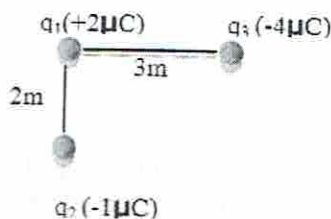

Solution:

$$F_e = k_e \frac{|q_1||q_2|}{r^2}$$

$$F_{31} = 8.9876 \times 10^9 \text{ N} \cdot \text{m}^2/\text{C}^2 \frac{|2\mu\text{C}||-4\mu\text{C}|}{3\text{m}^2} = 0.0080 \text{ N}$$

$$F_{21} = 8.9876 \times 10^9 \text{ N} \cdot \text{m}^2/\text{C}^2 \frac{|2\mu\text{C}||-1\mu\text{C}|}{2\text{m}^2} = 0.0045 \text{ N}$$

Recall that opposite forces attract and similar forces repel. Since q_2 and q_3 are positive and q_1 is negative, they exert attractive forces on q_1 . Therefore the directions of their respective force vectors, F_{21} and F_{31} , point from q_1 toward themselves.

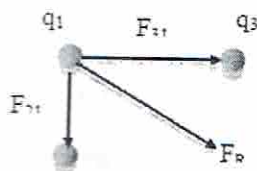

The resultant of the two forces F_R can be found using the Pythagorean Theorem:

$$F_R = \sqrt{F_{31}^2 + F_{21}^2} = \sqrt{.008^2 + .0045^2} = 0.0092 \text{ N}$$

Example 2.2

Two identical small charged spheres, each having a mass of 5.0×10^{-2} kg, hang in equilibrium as shown in Figure 2.2. The length of each string is 0.10 m, and the angle θ is 6.0° . Find the magnitude of the charge on each sphere.

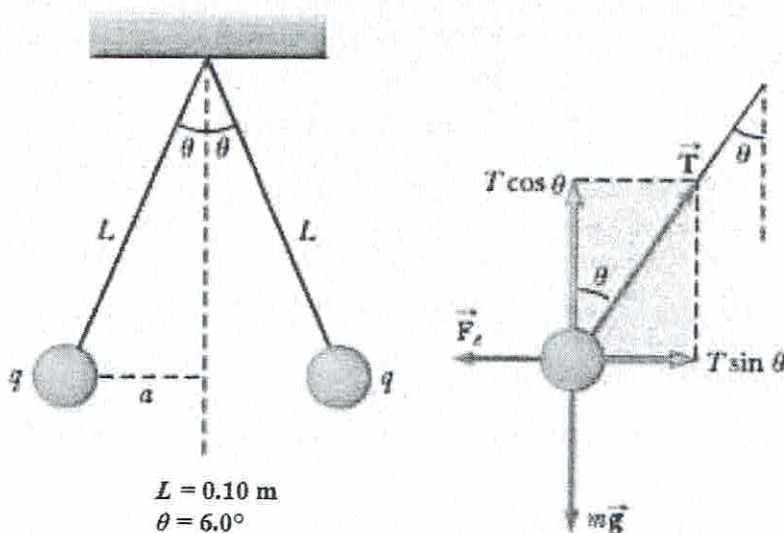

Figure 2.2 Two identical spheres carrying the same charge suspended in equilibrium. The free body diagram is for the sphere on the left.

(Source: http://www.nelsonbrain.com/content/serway12445_0495112445_02.01_chapter23.pdf)

Solution:

Force balance for left-hand sphere:

$$(1) \sum F_x = T \sin \theta - F_e = 0 \rightarrow T \sin \theta = F_e$$

$$(2) \sum F_y = T \cos \theta - mg = 0 \rightarrow T \cos \theta = mg$$

Divide (1) by (2):

$$\tan \theta = \frac{F_e}{mg} \rightarrow F_e = mg \tan \theta$$

$$F_e = (5.0 \times 10^{-2} \text{ kg}) \left(\frac{9.81 \text{ m}}{\text{s}^2} \right) \tan(6.0^\circ) = 5.16 \times 10^{-2} \text{ N}$$

Using the geometry of the triangle:

$$\sin \theta = \frac{a}{L} \rightarrow a = L \sin \theta = (0.10 \text{ m}) \sin(6.0^\circ) = 0.010 \text{ m}$$

Coulomb's law for each sphere:

$$F_e = k_e \frac{|q|^2}{r^2} \rightarrow |q| = \sqrt{\frac{F_e r^2}{k_e}} = \sqrt{\frac{F_e (2a)^2}{k_e}} = \sqrt{\frac{(5.16 \times 10^{-2} \text{ N})(2 \cdot 0.010 \text{ m})^2}{8.99 \times 10^9 \text{ N} \cdot \text{m}^2/\text{C}^2}} = \boxed{4.8 \times 10^{-8} \text{ C}}$$

2.2 The Electric Field

If an electric force is exerted on a test charge, an electric field exists. An electric field exists in a region of space around a charged object

$$\vec{E} = \text{Electr Field} \equiv \frac{\vec{F}_e}{q_o} \quad [N/C]$$

The direction of \vec{E} is in the direction of the force a positive test charge feels when placed in the field.

$$\vec{F}_e = \text{force exerted on test charge } q_o$$

$\vec{F}_e = q\vec{E}$ → If a charge q is put in an electric field, the force exerted on q is equal to its charge times the electric field.

Let q be the source charge and q_o be the test charge. Then \hat{r} is a unit vector directed from q to q_o . By Coulomb's Law, the force exerted by the source charge q on the test charge q_o is:

$$\vec{F}_e = k_e \frac{qq_o}{r^2} \hat{r}$$

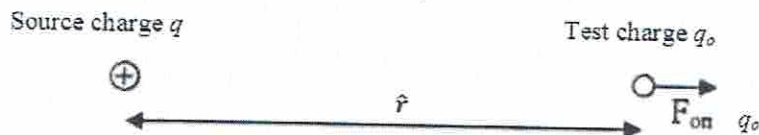

Therefore the electric field caused by a source charge q is: $\vec{E} = k_e \frac{q}{r^2} \hat{r}$

And the electric field caused by a number of charges q_i is: $\vec{E} = k_e \sum_i \frac{q_i}{r_i^2} \hat{r}_i$

Example 2.3

(Borrowed from

http://www.colorado.edu/physics/phys1120/phys1120_fa09/LectureNotes/ChargesElectricFields.pdf)

Example: Electric fields (qualitative) Four point charges, labeled 1 through 4, all with the same magnitude q , are placed around the origin as shown. Charge 2 is negative, the rest are positive. What is the direction of the E-field at the origin?

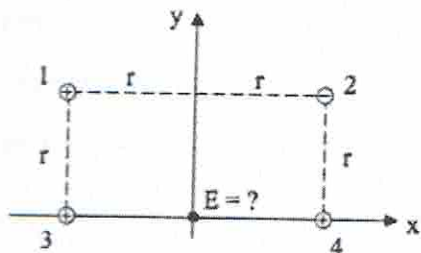

The total E-field at origin is the vector sum

$$\mathbf{E}_{\text{tot}} = \mathbf{E}_1 + \mathbf{E}_2 + \mathbf{E}_3 + \mathbf{E}_4$$

(I'll use bold type to indicate vector.)

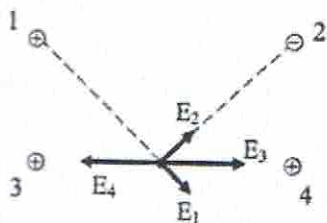

Notice that \mathbf{E}_3 and \mathbf{E}_4 cancel since they have equal magnitude, but opposite directions. The total E-field points right.

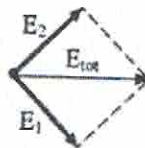

What would be the direction of the force on an electron (charge $q = -e$) placed at the origin?
 Since $\vec{E} = \vec{F}/q$, we have $\vec{F}_{\text{on } q} = q\vec{E}$. If q is negative, the direction of the force on q is opposite the direction of the E -field. So the force is to the left.



In this equation, the E -field is due to all the *other* charges, not the field due to the charge q itself.

Example Electric fields (quantitative) Two charge $Q_1 = +2e$ and $Q_2 = -3e$ are placed as shown. What the x -component of the electric field at the origin?

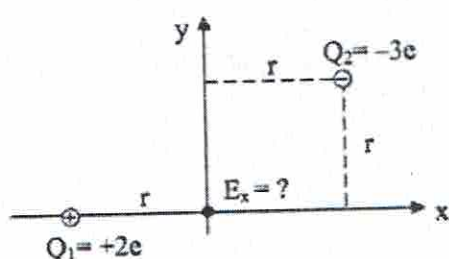

$$\vec{E}_{\text{tot}} = \vec{E}_1 + \vec{E}_2 \Rightarrow E_{\text{tot},x} = E_{1,x} + E_{2,x}$$

$$E_1 = k \frac{Q_1}{r^2} = k \frac{2e}{r^2}, \quad E_2 = k \frac{|Q_2|}{(\sqrt{2}r)^2} = k \frac{3e}{2r^2}$$

(Have used the fact that the distance from the origin to Q_2 is $\sqrt{2}r$)

$$E_{1,x} = E_1, \text{ since } E_1 \text{ is along the } x\text{-axis.}$$

$$E_{2,x} = E_2 \cos \theta = E_2 \cos 45^\circ \cong 0.707 E_2$$

$$\begin{aligned} E_{\text{tot},x} &= E_{1,x} + E_{2,x} = k \frac{2e}{r^2} + 0.707 k \frac{3e}{2r^2} \\ &= [2 + 0.707(3/2)] k \frac{e}{r^2} = 3.06 k \frac{e}{r^2} \end{aligned}$$

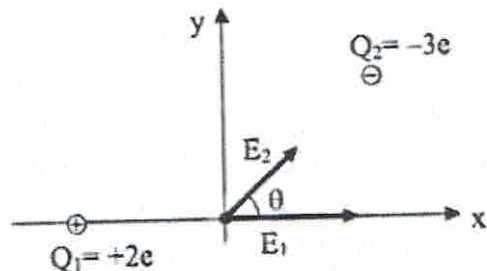

2.3 The Electric Field of a Continuous Charge Distribution

Coulomb's Law gives the force between two point charges. We have also determined the Electric field due to a single point charge or several point charges. Now we will look at how to handle a continuous charge distribution. We can sum up the electric field caused by each tiny, infinitesimal part of the charge distribution. This means an integral over the charge distribution (Fig. 2.3).

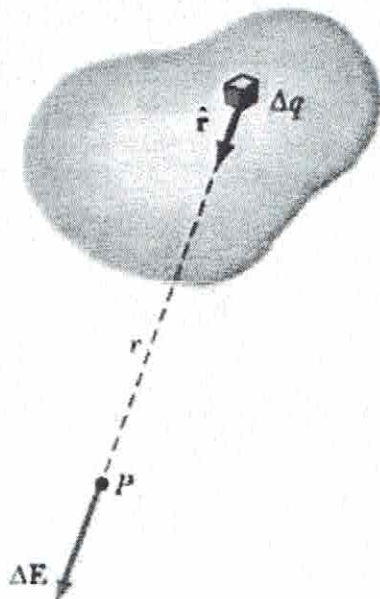

Figure 2.3 An Electric Field at P due to a continuous charge distribution is the vector sum of the infinitesimal electric fields ΔE due to all of the infinitesimal charges Δq .

Recall the electric field for a point charge:

$$\vec{E} = k_e \frac{q}{r^2} \hat{r}$$

And for multiple charges:

$$\vec{E} = k_e \sum_i \frac{q_i}{r_i^2} \hat{r}_i$$

Now we have a distribution of charge and we must replace q by Δq and E by ΔE :

$$d\vec{E} = k_e \frac{dq}{r^2} \hat{r}$$

$$\vec{E} = k_e \int \frac{dq}{r^2} \hat{r}$$

Convenient concept of charge densities ρ , σ and λ :

For a uniform charge distributed:

- Throughout a volume V : $\rho = Q/V$ [C/m³]
- Over a surface area A : $\sigma = Q/A$ [C/m²]
- Along a line of length l : $\lambda = Q/l$ [C/m]

For a nonuniformly charged distribution, the infinitesimal charges are accounted for:

$$dq = \rho dV \quad \text{or} \quad dq = \sigma dA \quad \text{or} \quad dq = \lambda dl$$

Example 2.4: Electric Field due to a Charged Rod

Required: Find the magnitude of the electric field at P due to one segment of the rod having a charge dq .

Solution:

Charge per unit length: $\lambda = Q/L$

Charge on segment dx : $dq = \lambda dx$

$$dE = k_e \frac{dq}{x^2} = k_e \frac{\lambda dx}{x^2}$$

$$E = k_e \lambda \int_D^{L+D} \frac{dx}{x^2} = k_e \lambda \left[-\frac{1}{x} \right]_D^{L+D}$$

$$E = k_e \lambda \left[-\frac{1}{x} \right]_D^{L+D} = k_e \frac{Q}{L} \left[\frac{1}{D} - \frac{1}{L+D} \right] = \boxed{\frac{k_e Q}{D(L+D)}}$$

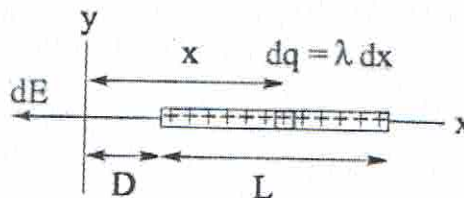

Example 2.5: Electric Field due to a Charged Ring

Required: Find the magnitude of the electric field at P due to the ring having a charge dq . The ring carries a uniformly distributed total charge Q .

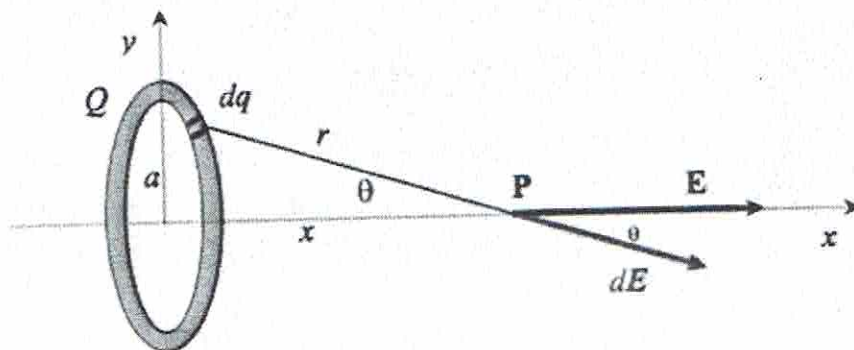

$$r = \sqrt{x^2 + a^2}$$

$$\cos \theta = \frac{x}{r} = \frac{x}{\sqrt{x^2 + a^2}}$$

Solution:

Due to symmetry, the perpendicular components of the field cancel. Therefore, only the parallel components, (in the x direction) need to be considered.

The parallel component of an electric field contribution from a segment of charge dq on the ring:

$$dE_x = k_e \frac{dq}{r^2} \cos \theta = k_e \frac{dq}{(x^2 + a^2)} \cos \theta = k_e \frac{dq}{(x^2 + a^2)} \frac{x}{\sqrt{x^2 + a^2}} = k_e \frac{x}{(x^2 + a^2)^{3/2}} dq$$

$$E_x = \int k_e \frac{x}{(x^2 + a^2)^{3/2}} dq = k_e \frac{x}{(x^2 + a^2)^{3/2}} \int dq$$

Since the total charge is equal to Q , $\int dq = Q$, so:

$$E = \frac{x}{(x^2 + a^2)^{3/2}} Q$$

Example 2.6: Electric Field due to a Charged Disk

Required: Find the magnitude of the electric field at P due to the disk having a uniform charge density σ . The ring carries a uniformly distributed total charge Q .

Solution:

$$dA = \sigma dA = \sigma (2\pi r dr) = 2\pi \sigma r dr$$

From Example 2.5,

$$dE_x = k_e \frac{x}{(x^2 + r^2)^{3/2}} dq = k_e \frac{x}{(x^2 + r^2)^{3/2}} 2\pi \sigma r dr$$

$$E_x = k_e x \pi \sigma \int_0^R \frac{2r}{(x^2 + r^2)^{3/2}} dr = k_e x \pi \sigma \int_0^R \frac{2r}{(x^2 + r^2)^{3/2}} dr = k_e x \pi \sigma \int_0^R (x^2 + r^2)^{-3/2} d(r^2)$$

$$= k_e x \pi \sigma \left[\frac{(x^2 + r^2)^{-1/2}}{-1/2} \right]_0^R = 2k_e \pi \sigma \left[1 - \frac{x}{(x^2 + R^2)^{1/2}} \right]$$

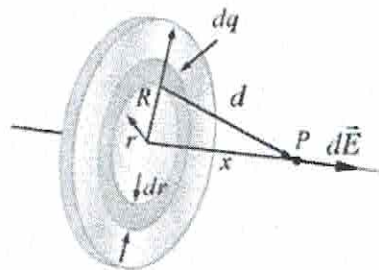

2.4 Motion of a Charged Particle in an Electric Field

If a particle of charge q and mass m is placed in an electric field E , the electric force exerted on the charge causes the particle to accelerate.

$$\vec{F}_e = q\vec{E} = m\vec{a}$$

The acceleration of the particle is

$$\vec{a} = \frac{q\vec{E}}{m}$$

If the charge is positive, its acceleration is in the direction of the field. If its charge is negative, its acceleration is in the opposite direction of the field.

Example 2.7

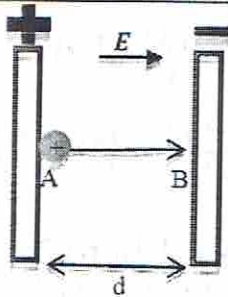

A charge q is released from rest at A. What is its velocity when it reaches B?

$$F = \text{constant} = ma$$

$$\vec{F}_e = q\vec{E}$$

$$x_f = x_i + v_i t + \frac{1}{2} a t^2$$

$$v_f^2 = v_i^2 + 2a(x_f - x_i) = v_i^2 + 2a(d) = 0 + 2a(d)$$

$$v_f = (2ad)^{1/2}$$

$$a = \frac{qE}{m}$$

Therefore,

$$v_f = \sqrt{\frac{2qEd}{m}}$$

Example 2.8

$F(+)$ same direction as E
 * $F(-)$ opposite direction as E

①

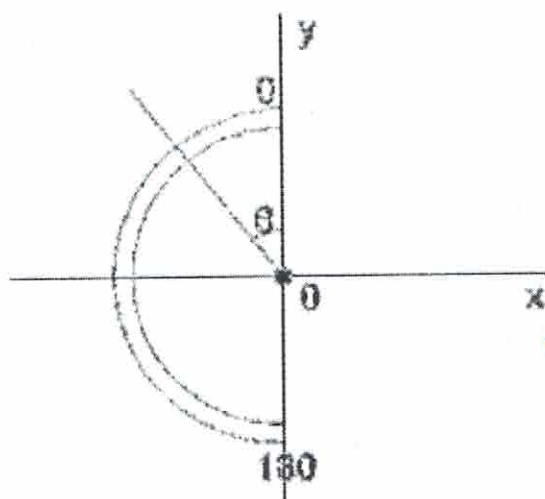

Required:

Find the magnitude and electric field at O, the center of the uniformly charged rod bent into a half-circle.

Given:

- The length of the rod is 15 cm.
- The rod has a total charge of $-8.5 \mu\text{C}$.

vector $\left\{ \begin{aligned} F_E &= \frac{Kq_1q_2}{r^2} \\ \vec{E} &= \frac{KQ}{r^2} \end{aligned} \right.$

scalar $\left\{ \begin{aligned} V &= \frac{KQ}{r} \\ U_e &= \frac{Kq_1q_2}{r} \end{aligned} \right.$

Handwritten notes: $F_E = Eq_0$, $\frac{KQ}{r^2} = E \cdot r = V$, $\frac{KQ}{r} \cdot q_2 = Vq_2 = U_e$

Solution:

- $L = 15.0 \text{ cm} = 0.15\text{m}$; $Q = -8.5 \mu\text{C}$; \vec{E} at O?

- Since the rod holds a continuous uniform charge, $\vec{E} = k_e \int \frac{dq}{r^2} \hat{r}$

$\vec{E} = E_x + E_y = E \sin\theta + E \cos\theta$

- Due to symmetry, $\vec{E}_y = 0$

$$E_x = \int dE \sin\theta = k_e \int \frac{dq}{r^2} \sin\theta$$

$$= k_e \int \frac{\lambda r d\theta}{r^2} \sin\theta$$

$$= \frac{k_e \lambda}{r} \int d\theta \sin\theta$$

$$\begin{aligned} dq &= \lambda dL \\ &= \lambda ds \\ &= \lambda d(r\theta) \\ &= \lambda r d\theta \end{aligned}$$

From 0° to 180° $E_x = \frac{k_e \lambda}{r} \int_0^\pi d\theta \sin\theta$

$$E_x = \frac{k_e \lambda}{r} [-\cos\theta]_0^\pi$$

$$E_x = \frac{(8.99 \times 10^9 \text{ N} \cdot \frac{\text{m}^2}{\text{C}^2}) (5.667 \times \frac{10^{-5} \text{ C}}{\text{m}}) \pi}{0.15\text{m}} [-\cos\pi + \cos 0]$$

$$E_x = 2.13 \times 10^7 \text{ N/C}$$

Handwritten notes:

$$\Delta K + \Delta U_e = 0$$

$$(K_f - K_i) + (\Delta V_{A-B} \cdot q_0)$$

$$(\frac{1}{2} m_f^2 - \frac{1}{2} m_i^2) + (-Ed)q_0 = 0$$

$$V_f = \frac{Edq_0}{\frac{1}{2}m}$$

$$\begin{aligned} \lambda &= Q/L \\ &= \frac{8.5 \mu\text{C}}{0.15\text{m}} \\ &= 5.667 \times 10^{-5} \text{ C/m} \end{aligned}$$

$$\begin{aligned} 2(0.15\text{m}) &= 2\pi r \\ r &= \frac{0.15\text{m}}{\pi} \end{aligned}$$

- Since the rod has a negative charge, the direction of the electric field at O is in the negative x direction:

$$E_x = \left(-2.13 \times 10^7 \frac{\text{N}}{\text{C}} \right) \hat{i}$$

Topic 3: Gauss's Law

(Reference: *Physics for Scientists and Engineers by Serway and Jewett, 7th ed., Chapter 24*)

3.1 Electric Flux

Electric flux is proportionate to the number of electric field lines that enter and exit a surface (Fig. 3.1). If the electric field is uniform and the makes an angle θ with the normal to a surface with area A , then the electric flux going through the surface is given by:

$$\Phi_E = \vec{E} \cdot \vec{A} = EA \cos \theta$$

And more generally, for a non-planar area:

$$\Phi_E = \int_{\text{surf}} \vec{E} \cdot d\vec{A}$$

(Recall the dot product: $u \cdot v = \|u\| \|v\| \cos \theta$)

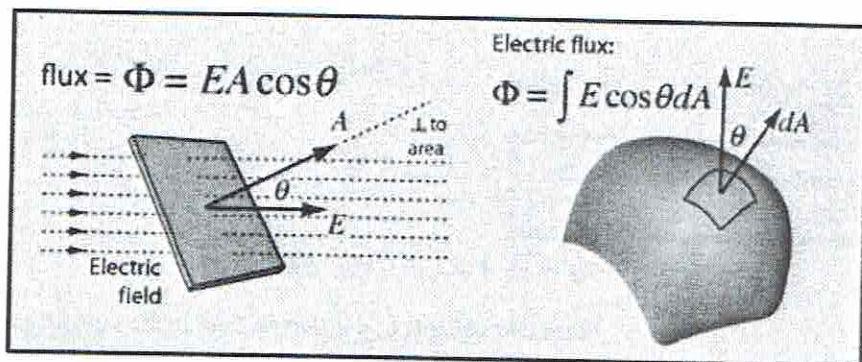

Figure 3.1 The electric flux is determined by the dot product of the area A and electric field E . When the area is treated as a vector in this manner, the magnitude of the vector is equal to the area and the direction of the vector is perpendicular (or normal) to the surface.

(Source: <http://hyperphysics.phy-astr.gsu.edu/hbase/electric/gaulaw.html>)

3.2 Gauss's Law

Gauss's law states that the net electric flux Φ_E through any closed Gaussian surface is equal to the net charge q_{in} inside the surface, divided by the permittivity of free space, ϵ_0 :

$$\Phi_E = \oint \vec{E} \cdot d\vec{A} = \frac{q_{in}}{\epsilon_0}$$

Gauss's law provides a convenient way to calculate the electric field due to various symmetric charge distributions, which will be reviewed in the sample problems at the end of this section.

3.3 Conductors in Electrostatic Equilibrium

An electrical conductor contains charges that are free to move about in the material. When there is no net motion of charge within a conductor, the conductor is in **electrostatic equilibrium**, and has the following properties:

1. The electric field is zero everywhere inside the conductor, whether the conductor is solid or hollow.
2. If an isolated conductor carries a charge, the charge resides on the surface.
3. The electric field just outside a charged conductor is perpendicular to the surface of the conductor and has a magnitude σ/ϵ_0 , where σ is the surface charge density at that point:

$$\Phi_E = \oint \vec{E} \cdot d\vec{A} = EA = \frac{q_{in}}{\epsilon_0} = \frac{\sigma A}{\epsilon_0} \rightarrow E = \frac{\sigma}{\epsilon_0}$$

4. On an irregularly shaped conductor, the surface charge density is greatest at locations where the radius of curvature of the surface is smallest.

(Serway & Jewett, 2008)

Topic 3: Gauss's Law Sample Problems

Example 3.1

A uniform electric field $\vec{E} = a\hat{i} + b\hat{j}$ intersects a surface of area A . Determine the flux through this area if the surface lies:

(a) In the yz plane, (b) in the xz plane, and (c) in the xy plane.

Solution:

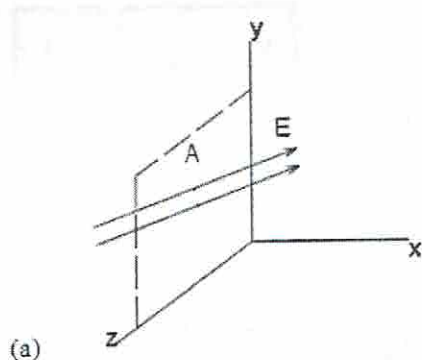

$$\Phi_E = \vec{E} \cdot \vec{A} = (a\hat{i} + b\hat{j}) \cdot A\hat{i} = \boxed{aA}$$

Since components of the electric field in the \hat{j} direction are parallel to the surface area, they do not contribute to the electric flux.

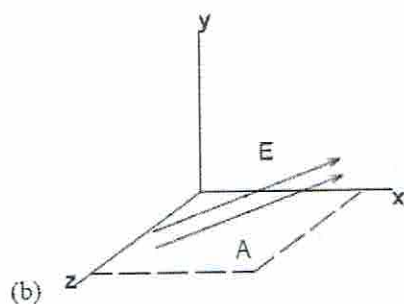

$$\Phi_E = \vec{E} \cdot \vec{A} = (a\hat{i} + b\hat{j}) \cdot A\hat{j} = \boxed{bA}$$

Since components of the electric field in the \hat{i} direction are parallel to the surface area, they do not contribute to the electric flux.

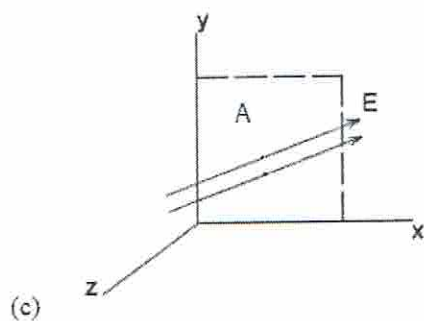

$$\Phi_E = \boxed{0}$$

Since the electric field is parallel to the surface, there is no electric flux through the surface.

Example 3.2

A pyramid with horizontal square base, 5.0 m on each side, and a height of 6 m is placed in a vertical electric field of 55.0 N/C. Calculate the total electric flux through the pyramid's four slanted surfaces.

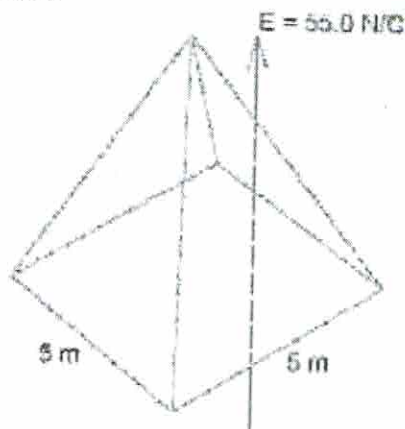
Solution

The number of electric field lines entering a closed surface equals the number of electric field lines leaving the surface.

The vertical field lines enter through the horizontal base of area
 $A = (5.0 \text{ m})^2 = 25.0 \text{ m}^2$

The normal to the horizontal surface points away from the pyramid, vertically downward. Since the electric field lines are directed vertically upward, the angle θ between the \vec{E} and the normal to the surface is 180° .

$$\Phi_E = \vec{E} \cdot \vec{A} = EA \cos \theta = (55.0 \text{ N/C})(25.0 \text{ m}^2) \cos 180^\circ = -1,375 \text{ N} \cdot \text{m}^2/\text{C}$$

The total electric flux through the pyramid's top surfaces is
 $\Phi_E = +1,375 \text{ N} \cdot \text{m}^2/\text{C}$

Example 3.3: Gauss's Law Application

An infinitely long line charge having a uniform charge per unit length λ lies a distance d from point O as shown. Find the total electric flux through the surface of a sphere of radius R centered at O that results from this line charge if:

(a) $R < d$, and (b) $R > d$.

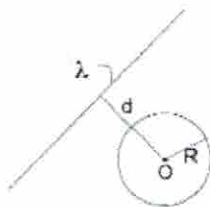
Solution

$$\Phi_E = \frac{q_{in}}{\epsilon_0}$$

a) **If $R < d$:**

All charge is located outside of the closed surface of the sphere, and

$$\Phi_E = \frac{q_{in}}{\epsilon_0} = 0.$$

There is no net flux through the sphere.

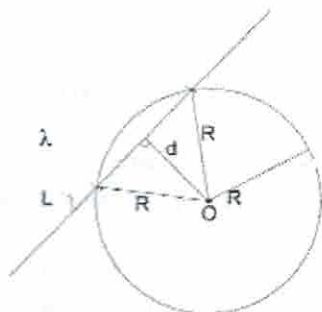

b) **If $R > d$:**

Any line through the origin of a circle and perpendicular to any chord on that circle will bisect the chord and therefore the length of the line falling within the sphere is $l = 2\sqrt{R^2 - d^2}$

$$dq = \lambda dl \text{ and } q_{in} = 2\lambda\sqrt{R^2 - d^2}$$

$$\Phi_E = \frac{q_{in}}{\epsilon_0} = \frac{2\lambda\sqrt{R^2 - d^2}}{\epsilon_0}$$

Example 3.4

A solid, insulating sphere with a radius a has a uniform charge density ρ and total charge Q . This sphere is located inside of an uncharged, conducting hollow sphere with inner and outer radii of b and c as shown.

(a) Determine the magnitude of the electric field in the following areas:

1. $r < a$
2. $a < r < b$
3. $b < r < c$
4. $r > c$

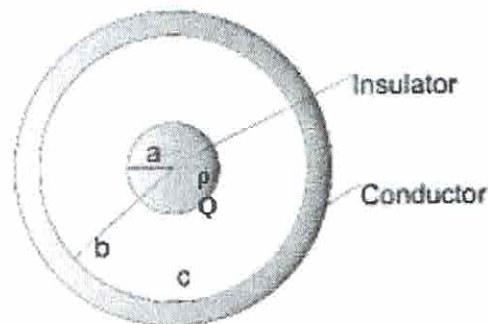

Solution:

$$\Phi_E = \oint \vec{E} \cdot d\vec{A} = E(4\pi r^2) = \frac{q_{in}}{\epsilon_0}$$

1. $r < a$:

Uniformly charged volume: $\rho = Q/V$

$$q_{in} = Q = \rho V = \rho \frac{4}{3}\pi r^3 \quad \rightarrow \quad E(4\pi r^2) = \frac{\rho \frac{4}{3}\pi r^3}{\epsilon_0} \quad \rightarrow \quad \boxed{E = \frac{\rho r}{3\epsilon_0}}$$

2. $a < r < b$:

Electric field due to uniformly charged sphere in the region external to sphere: $q_{in} = Q$

$$E(4\pi r^2) = \frac{Q}{\epsilon_0} \rightarrow E = \frac{Q}{4\pi r^2 \epsilon_0}$$

Since the shell is a conductor, it has no effect on the field due to the inner uniformly charged sphere. Therefore the electric field on the inside of the conducting shell ($a < r < b$) and the electric field outside the shell ($r > c$) vary only with their distance r from the uniformly charged sphere.

3. $b < r < c$:

$E = 0$ since the electric field is zero everywhere inside a conductor.

4. $r > c$: See part 2.

(b) Determine the induced charge per unit area on the inner and outer surfaces of the hollow sphere.

Solution:

$$q_{in} = \sigma_{in} A_{in} = \sigma_{in} 4\pi b^2$$

$$\sigma_{in} = \frac{q_{in}}{4\pi b^2}$$

σ = surface charge density

q_{in} = induced charge on inner surface of hollow sphere

Since $E = 0$ inside the conductor, $q_{in} = -Q$ to cancel the charge $+Q$ from the solid inner sphere.

Therefore, $\boxed{\sigma_{in} = \frac{-Q}{4\pi b^2}}$

q_{out} = induced charge on the outer surface of the hollow sphere. Since the hollow sphere (shell) is uncharged, $q_{in} + q_{out} = 0$.

Therefore $q_{out} = +Q$ and $\boxed{\sigma_{out} = \frac{+Q}{4\pi c^2}}$

Topic 4: Electric Potential

(Reference: *Physics for Scientists and Engineers by Serway and Jewett, 7th ed., Chapter 25*)

4.1 Potential Difference

The potential difference, ΔV between two points A and B in an electric field \mathbf{E} is defined as

$$\Delta V \equiv \frac{\Delta U}{q_0} = - \int_A^B \vec{E} \cdot d\vec{s}$$

The electric potential $V = U/q_0$ is a scalar quantity and has the units of joules per coulomb, where 1 J/C is equivalent to 1V.

An equipotential surface is one on which all points are at the same electric potential. Equipotential surfaces are perpendicular to electric field lines.

When a positive test charge q_0 is moved between points A and B in an electric field \mathbf{E} , the change in the potential energy of the charge-field system is

$$\Delta U = -q_0 \int_A^B \vec{E} \cdot d\vec{s}$$

The potential difference between two points A and B separated by a distance d in a uniform electric field \mathbf{E} , where \mathbf{s} is a vector that points from A toward B and is parallel to \mathbf{E} , is

$$\Delta V \equiv -E \int_A^B ds = -Ed$$

If $V = 0$ at $r = \infty$, the electric potential due to a point charge at any distance r from the charge is

$$V = k_e \frac{q}{r}$$

The electric potential associated with a group of point charges is obtained by summing the potentials due to the individual charges.

4.2 Electric Potential Energy due to Point Charges

The potential energy associated with a pair of point charges separated by a distance r_{12} is

$$U = k_e \frac{q_1 q_2}{r_{12}}$$

We obtain the potential energy of a distribution of point charges by summing the potential energies over all pairs of particles.

If the electric potential is known as a function of coordinates x , y , and z , the components of the electric field can be obtained as follows:

$$E_x = -\frac{dV}{dx}, \quad E_y = -\frac{dV}{dy}, \quad E_z = -\frac{dV}{dz}$$

4.2 Electric Potential Energy due to a Continuous Charge Distribution

The electric potential due to a continuous charge distribution is

$$V = k_e \int \frac{dq}{r}$$

Each point on the surface of a charged conductor in electrostatic equilibrium is at the same electric potential. The potential is constant everywhere inside the conductor and equal to its value at the surface.

Topic 4: Electric Potential Sample Problems

Example 4.1

An insulating rod with a linear charge density of $\lambda = 30.0 \mu\text{C/m}$ and linear mass density of $\mu = 0.200 \text{ kg/m}$ is released from rest in a uniform electric field $E = 110 \text{ V/m}$ directed perpendicular to the rod.

Required: Find the speed, v , of the rod after it has traveled 3 m.

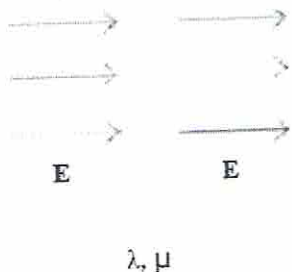

Solution:

- $d = 3.0 \text{ m}$
- $L = \text{length of rod}$
- $v_i = 0$
- $\Delta V = -Ed$
- $\Delta U = q_o \Delta V$
- $q_o = \lambda L$
- $m = \mu L$

Energy Balance:

$$\Delta K + \Delta U = 0$$

$$(K_f - K_i) + (U_f - U_i) = 0$$

$$\left(\frac{1}{2}\mu L v^2 - 0\right) + (0 - \lambda L E d) = 0$$

$$v = \sqrt{\frac{2\lambda L E d}{\mu L}} = \sqrt{\frac{2(30.0 \times 10^{-6})(110)(3.0)}{(0.20)}} = \boxed{0.445 \text{ m/s}}$$

Example 4.2

Calculate the electric potential at the midpoint of the base of the triangle shown below due to the three charged particles at the vertices. Assume $q = 6.00 \mu\text{C}$.

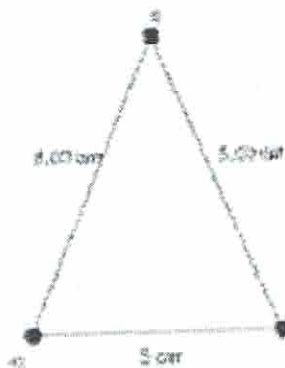

$$h = \sqrt{5.00^2 - 1.50^2} = 4.77 \text{ cm}$$

$$V = \sum_i k_e \frac{q_i}{r_i} = \sum_i \left(8.99 \times 10^9 \text{ N} \cdot \frac{\text{m}^2}{\text{C}^2}\right) \left[\frac{6.00 \mu\text{C}}{4.77 \text{ cm}} - \frac{2(6.00 \mu\text{C})}{1.50 \text{ cm}}\right]$$

$$V = -6.06 \text{ MV}$$

* Does not depend on shape or size only the charge inside

GAUSS'S LAW

$$\phi E = EA \cos \theta \text{ between } \hat{n} \text{ of } A \text{ and } E$$

* the reason $\phi_E = 0$ due to outside charge. wtv goes in (-) comes out (+) net $\phi = 0$

$$E = \frac{q_{in}}{A \cos \theta \epsilon_0}$$

$$E_{(r)} = \frac{\lambda h}{2\pi r h \epsilon_0} = \frac{\lambda}{2\pi \epsilon_0 r}$$

- step 1: state Gausslaw
- step 2: isolate for E
- step 3: λ or q . what is q , q
- step 4: simplify

$$\phi E = EA \cos 60^\circ = 100(2)^{\frac{1}{2}} = 100 \text{ N/cm}^2$$

$$\phi E = EA \cos \theta = \frac{q_{in}}{\epsilon_0}$$

$$E = \frac{q_{in}}{A \cos \theta \epsilon_0}$$

starting point

* always use a surface where $\theta = 0$

Example 4.3

A rod of length L lies along the x axis with its left end at the origin and has a non-uniform charge density $\lambda = \alpha x$ (where α is a positive constant).

- (a) What are the units of α ? (b) Calculate the electric potential at A

Solution:

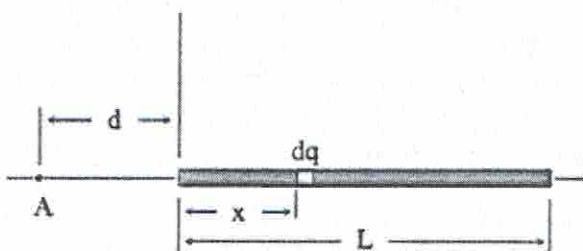

(a) Recall that the linear charge density is 1 C/m and the unit of length is 1 m . Whenever there is a relationship between two physical quantities expressed in the form of an equation, the units on both sides must be the same. This requires that the coefficient α in the equation $\lambda(x) = \alpha x$ has unit C/m^2

b)

$$V = k_e \int_0^L \frac{dq}{r}$$

$$dq = \lambda dx = \alpha x dx$$

$$r = d + x$$

$$V = k_e \int_0^L \frac{\alpha x dx}{d + x} = k_e \alpha \int_0^L \frac{x dx}{d + x}$$

Appendix B, Serway and Jewett:

$$\int \frac{x dx}{a + bx} = \frac{x}{b} - \frac{a}{b^2} \ln(a + bx)$$

Here, $a = d$ and $b = 1$, so:

$$\begin{aligned} k_e \alpha \int_0^L \frac{x dx}{d + x} &= k_e \alpha [x - d \ln(d + x)]_0^L = k_e \alpha [L - d \ln(d + L) - d \ln d] \\ &= k_e \alpha \left[L - d \ln \left(\frac{d + L}{d} \right) \right] \\ &= k_e \alpha \left[L - d \ln \left(1 + \frac{L}{d} \right) \right] \end{aligned}$$

ROD
 $\lambda = \frac{Q_T}{L} \text{ (C/m)}$

PLANE
 $\sigma = \frac{Q_T}{A} \text{ (C/m}^2\text{)}$

SPHERE
 $\rho = \frac{Q_T}{\text{Vol.}} \text{ (C/m}^3\text{)}$

GAUSS LAW
 infinite 1D (rod)
 infinite 2D (plate, disc)
 3D symmetrical (sphere, cylinder)

integration
 finite 1D wire
 finite 2D disk, plate

Topic 5: Capacitors and Dielectrics

(From: *Physics for Scientists and Engineers by Serway and Jewett, 7th ed., Chapter 26*)

5.1 Capacitance

A capacitor consists of two conductors carrying charges of equal magnitude and opposite sign. The capacitance C of any capacitor is the ratio of the charge Q on either conductor to the potential difference ΔV between them:

$$C = \frac{Q}{\Delta V}$$

The capacitance depends only on the geometry of the conductors and not on an external source of charge or potential difference. The unit of capacitance is coulombs per volt, or the farad (F): $1 \text{ F} = \text{C/V}$.

The electric dipole moment \mathbf{p} of an electric dipole has a magnitude $p = 2aq$ where $2a$ is the distance between the charges q and $-q$. The direction of the electric dipole moment vector is from the negative charge toward the positive charge.

5.2 Combinations of Capacitors

If two or more capacitors are connected in parallel, the potential difference is the same across all capacitors. The equivalent capacitance of a parallel combination of capacitors is:

$$C_{\text{eq}} = C_1 + C_2 + C_3 + \dots$$

If two or more capacitors are connected in series, the charge is the same on all capacitors, and the equivalent capacitance of the series combination is given by:

$$1/C_{\text{eq}} = 1/C_1 + 1/C_2 + 1/C_3 + \dots$$

These two equations enable you to simplify many electric circuits by replacing multiple capacitors with a single equivalent capacitance.

5.3 Energy Stored in a Charged Capacitor

Energy is stored in a charged capacitor because the charging process is equivalent to the transfer of charges from one conductor at a lower electric potential to another conductor at a higher potential. The energy stored in a capacitor of capacitance C with charge Q and potential difference ΔV is:

$$U_E = \frac{Q^2}{2C} = \frac{1}{2}Q\Delta V = \frac{1}{2}C(\Delta V)^2$$

5.4 Capacitors with Dielectrics

When a dielectric material is inserted between the plates of a capacitor, the capacitance increases by a dimensionless factor κ , called the dielectric constant:

$$C = \kappa C_0,$$

where C_0 is the capacitance in the absence of the dielectric.

5.5 Electric Dipole in an Electric Field

The torque acting on an electric dipole in a uniform electric field \mathbf{E} is the cross product $\boldsymbol{\tau} = \mathbf{p} \times \mathbf{E}$

The potential energy of the system of an electric dipole in a uniform external electric field \mathbf{E} is the dot product $U_E = -\mathbf{p} \cdot \mathbf{E}$.

Example 5.1 Combinations of Capacitors

Find the equivalent capacitance C between terminals X and Y of the infinite set of capacitors represented in the figure below, from Physics for Scientists and Engineers by Serway and Jewett, 7th ed., Chapter 26. Each capacitor has capacitance C_0 . **Hints:**

- Imagine that the circuit is cut at the line AB
- The equivalent capacitance of the infinite section to the right of AB is also C .

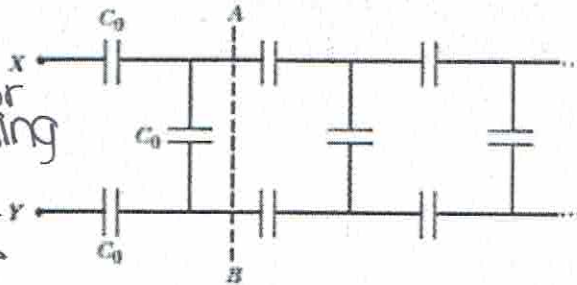

Resistor
everything
that consumes
electricity

capacitor
everything
that is
recharge-
able

Solution:

The circuit can be represented as follows:

* pipe
resistance
(clogged)

RESISTOR



$$R = \rho \frac{L}{A}$$

resistivity (given)

$$R = \frac{V}{I}$$

cannot change R



$$R_{eq} = R_1 + R_2 \dots$$

$$I_1 = I_2 = I_T$$

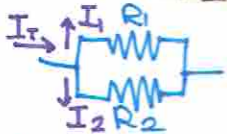

$$\frac{1}{R_{eq}} = \frac{1}{R_1} + \frac{1}{R_2} \dots$$

$$I_T = I_1 + I_2$$

Power = $I^2 R$
(use circ. eq'n to solve for amp)
 $= \frac{V^2}{R} = VI$

* container of charges

CAPACITOR



$$C = \epsilon_0 \frac{A}{d}$$

geometrical eq'n

$$C = \frac{Q}{V}$$

cannot change R

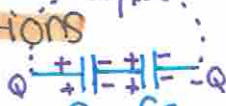

series $\frac{1}{C_{eq}} = \frac{1}{C_1} + \frac{1}{C_2} \dots$

$$C = \frac{Q_T - 2C_0 \pm \sqrt{(2C_0)^2 - 4(2)(C_0^2)}}{2(2)}$$



Parallel $C_{eq} = C_1 + C_2 \dots$

$$Q_T = Q_1 + Q_2$$

follow ratio

$$U_E = \frac{Q^2}{2C}$$

$$= \frac{1}{2} VQ$$

(derive using circuit eq'n)

current = $I = \frac{dq}{dt} = 12A$
(flow of charge)

give $q(t) = 2t + 10t + 7$
12

$$\frac{1}{C} = \frac{2}{C_0} + \frac{1}{C + C_0}$$

$$\frac{1}{C} = \frac{2C + 3C_0}{C_0(C + C_0)}$$

$$C_0 C^2 + C_0^2 = 2C^2 + 3C_0 C$$

$$0 = 2C^2 + 2C_0 C - C_0^2$$

$$C = -\frac{1}{2}(C_0 \pm \sqrt{3}C_0)$$

$$C = -\frac{C_0}{2}(1 \pm \sqrt{3})$$

$$C = \frac{C_0}{2}(\sqrt{3} - 1)$$

Only the positive root has physical meaning:

Example 5.2 Capacitance(Source: http://www.phys.hawaii.edu/~morse/P272fall10-7_pdf.pdf)

- Calculate the capacitance:
- Assume $+Q$, $-Q$ on plates with potential difference V .

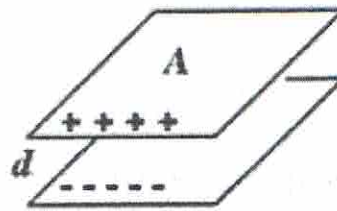

$$E = \frac{\sigma}{\epsilon_0} = \frac{Q}{A\epsilon_0}$$

$$V_b - V_a = -\int_a^b \vec{E} \cdot d\vec{l} = Ed = \frac{Q}{A\epsilon_0} d \quad \Rightarrow \quad C = \frac{Q}{V} = \frac{A\epsilon_0}{d}$$

- As expected, the capacitance of this capacitor depends only on its GEOMETRY (A, d). **DOES NOT DEPEND** on Q or on V !!!!!
- Note that $C \sim$ length; this will *always* be the case!

Example 5.3 Energy Stored and Power Generated in Capacitors(Source: http://www.engineeringtoolbox.com/capacitors-energy-power-d_1389.html)Calculate the energy stored in a $10 \mu\text{F}$ capacitor charged to 230 V .

$$U_E = \frac{1}{2} C (\Delta V)^2$$

$$U = 1/2 (10 \times 10^{-6} \text{ F}) (230 \text{ V})^2$$

$$= \underline{0.26 \text{ Joules}}$$

Hypothetically - if this energy is dissipated within $5 \mu\text{s}$ the potential power generated can be calculated as

$$P = (0.26 \text{ Joules}) / (5 \times 10^{-6} \text{ s})$$

$$= \underline{52000 \text{ W}}$$

$$= \underline{52 \text{ kW}}$$

Be aware that in any real circuit, discharge starts at a peak value and declines. The energy dissipated is a very rough average power over the discharge pulse.

Topic 6: Current and Resistance

(From: *Physics for Scientists and Engineers* by Serway and Jewett, 7th ed., Chapter 27)

6.1 Electric Current and Resistance

The electric current I in a conductor is defined as

$$I = \frac{dQ}{dt}$$

where dQ is the charge that passes through a cross section of the conductor in a time interval dt . The SI unit of current is the ampere (A), where $1 \text{ A} = 1 \text{ C/s}$.

The resistance R of a conductor is defined as:

$$R = \frac{\Delta V}{I}$$

where ΔV is the potential difference across the conductor and I is the current it carries. The SI unit of resistance is volts per ampere, which is defined to be 1 ohm (Ω); that is, $1 \text{ V} = 1 \text{ V/A}$.

For a uniform block of material of cross-sectional area A and length l , the resistance over the length l is

$$R = \rho \frac{l}{A}$$

where ρ is the resistivity of the material.

6.1 Electrical Power

If a potential difference ΔV is maintained across a circuit element, the power, or rate at which energy is supplied to the element, is:

$$P = I\Delta V$$

Because the potential difference across a resistor is given by $\Delta V = IR$ we can express the power delivered to a resistor as:

$$P = I^2 R = \frac{(\Delta V)^2}{R}$$

Example 6.1

A 600 W heating coil designed to operate from 100 V is made out of wire 0.400 mm in diameter.

Assuming the wire's resistivity remains constant at $\rho = 1.6 \times 10^{-6} \Omega \cdot \text{m}$; find the length of wire used.

Solution:

$$R = \rho \frac{l}{A} \rightarrow \rho = R \frac{A}{l}$$

$$A = \pi r^2 = \pi (0.200 \text{ mm} \times 10^{-3})^2 = 1.26 \times 10^{-7} \text{ m}^2$$

$$P = \frac{(\Delta V)^2}{R} \rightarrow R = \frac{(\Delta V)^2}{P} = \frac{(100 \text{ V})^2}{600 \text{ W}} = 16.7 \Omega$$

$$l = R \frac{A}{\rho} = 16.7 \Omega \frac{1.26 \times 10^{-7} \text{ m}^2}{1.6 \times 10^{-6} \Omega \cdot \text{m}} = 1.31 \text{ m}$$

Topic 7: Direct Current Circuits

(From: *Physics for Scientists and Engineers by Serway and Jewett, 7th ed., Chapter 28*)

7.1 Resistors in Series and Parallel

Parallel Circuit

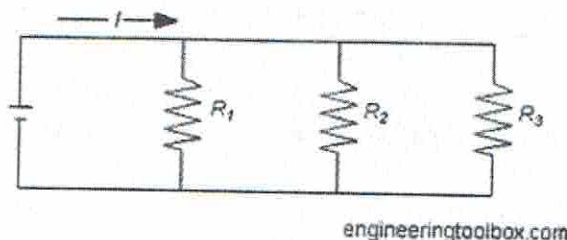

engineeringtoolbox.com

The sum of current in a parallel network can be expressed as

$$I = I_1 + I_2 + \dots + I_n \quad (1)$$

where

I = sum of currents (Amps)

The total resistance in a parallel circuit can be expressed as

$$1/R = 1/R_1 + 1/R_2 + \dots + 1/R_n \quad (2)$$

where

R = total resistance in the parallel network (Ohms, Ω)

Example 7.1 Parallel Network

(Source: http://www.engineeringtoolbox.com/parallel-networks-d_1385.html)

The total resistance in a network with three resistors $R_1 = 10 \Omega$, $R_2 = 20 \Omega$ and $R_3 = 30 \Omega$ can be calculated as

$$1/R = 1/(10 \Omega) + 1/(20 \Omega) + 1/(30 \Omega)$$

$$= 0.183 (1/\Omega)$$

$$R = 1/0.183$$

$$= \underline{5.46 \Omega}$$

Connected to a 12 V battery the sum of currents can be calculated

$$I = U/R$$

$$= (12 \text{ V}) / (5.46 \Omega)$$

$$= \underline{2.2 \text{ Amps}}$$

The current through each resistor can be calculated as

$$I_1 = U/R_1$$

$$= (12 \text{ V}) / (10 \Omega)$$

$$= \underline{1.2 \text{ (Amps)}}$$

$$I_2 = U/R_2$$

$$= (12 \text{ V}) / (20 \Omega)$$

$$= \underline{0.6 \text{ (Amps)}}$$

$$I_3 = U/R_3$$

$$= (12 \text{ V}) / (30 \Omega)$$

$$= \underline{0.4 \text{ (Amps)}}$$

Series circuits

A series circuit is a circuit in which resistors are arranged in a chain, so the current has only one path to take. The current is the same through each resistor. The total resistance of the circuit is found by simply adding up the resistance values of the individual resistors:

equivalent resistance of resistors in series : $R = R_1 + R_2 + R_3 + \dots$

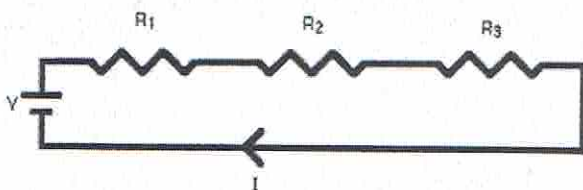

A series circuit is shown in the diagram above. The current flows through each resistor in turn. If the values of the three resistors are:

$R_1 = 8 \Omega$, $R_2 = 8 \Omega$, and $R_3 = 4 \Omega$, the total resistance is $8 + 8 + 4 = 20 \Omega$.

With a 10 V battery, by $V = I R$ the total current in the circuit is:

$I = V / R = 10 / 20 = 0.5 \text{ A}$. The current through each resistor would be 0.5 A.

A parallel resistor short-cut

If the resistors in parallel are identical, it can be very easy to work out the equivalent resistance. In this case the equivalent resistance of N identical resistors is the resistance of one resistor divided by N , the number of resistors. So, two 40-ohm resistors in parallel are equivalent to one 20-ohm resistor; five 50-ohm resistors in parallel are equivalent to one 10-ohm resistor, etc.

When calculating the equivalent resistance of a set of parallel resistors, people often forget to flip the $1/R$ upside down, putting $1/5$ of an ohm instead of 5 ohms, for instance. Here's a way to check your answer. If you have two or more resistors in parallel, look for the one with the smallest resistance. The equivalent resistance will always be between the smallest resistance divided by the number of resistors, and the smallest resistance. Here's an example.

You have three resistors in parallel, with values 6 ohms, 9 ohms, and 18 ohms. The smallest resistance is 6 ohms, so the equivalent resistance must be between 2 ohms and 6 ohms ($2 = 6/3$, where 3 is the number of resistors).

Doing the calculation gives $1/6 + 1/12 + 1/18 = 6/18$. Flipping this upside down gives $18/6 = 3$ ohms, which is certainly between 2 and 6.

Circuits with series and parallel components

Many circuits have a combination of series and parallel resistors. Generally, the total resistance in a circuit like this is found by reducing the different series and parallel combinations step-by-step to end up with a single equivalent resistance for the circuit. This allows the current to be determined easily. The current flowing through each resistor can then be found by undoing the reduction process.

General rules for doing the reduction process include:

1. Two (or more) resistors with their heads directly connected together and their tails directly connected together are in parallel, and they can be reduced to one resistor using the equivalent resistance equation for resistors in parallel.
2. Two resistors connected together so that the tail of one is connected to the head of the next, with no other path for the current to take along the line connecting them, are in series and can be reduced to one equivalent resistor.

Finally, remember that for resistors in series, the current is the same for each resistor, and for resistors in parallel, the voltage is the same for each one.

7.1 Resistors in Series and Parallel

(Source: http://www.electronics-tutorials.ws/dccircuits/dcp_4.html)

* any circuit with both resistor and capacitor → RC

Kirchhoff's First Law - The Current Law, (KCL)

Kirchhoff's Current Law or KCL, states that the "total current or charge entering a junction or node is exactly equal to the charge leaving the node as it has no other place to go except to leave, as no charge is lost within the node". In other words the algebraic sum of ALL the currents entering and leaving a node must be equal to zero, $I_{(exiting)} + I_{(entering)} = 0$. This idea by Kirchhoff is commonly known as the **Conservation of Charge**.

* any circuit with multiple battery → Kirchhoff's

Kirchhoff's Current Law

Currents Entering the Node
Equals
Currents Leaving the Node

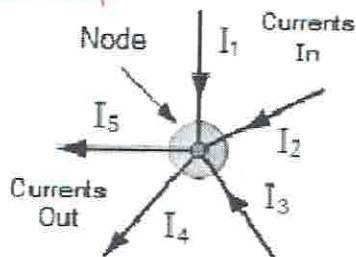

$$I_1 + I_2 + I_3 + (-I_4 - I_5) = 0$$

Here, the 3 currents entering the node, I_1, I_2, I_3 are all positive in value and the 2 currents leaving the node, I_4 and I_5 are negative in value. Then this means we can also rewrite the equation as:

$$I_1 + I_2 + I_3 - I_4 - I_5 = 0$$

The term **Node** in an electrical circuit generally refers to a connection or junction of two or more current carrying paths or elements such as cables and components. Also for current to flow either in or out of a node a closed circuit path must exist. We can use Kirchhoff's current law when analyzing parallel circuits.

Kirchhoff's Second Law - The Voltage Law, (KVL)

Kirchhoff's Voltage Law or KVL, states that "in any closed loop network, the total voltage around the loop is equal to the sum of all the voltage drops within the same loop" which is also equal to zero. In other words the algebraic sum of all voltages within the loop must be equal to zero. This idea by Kirchhoff is known as the **Conservation of Energy**.

Kirchhoff's Voltage Law

The sum of all the Voltage Drops around the loop is equal to Zero

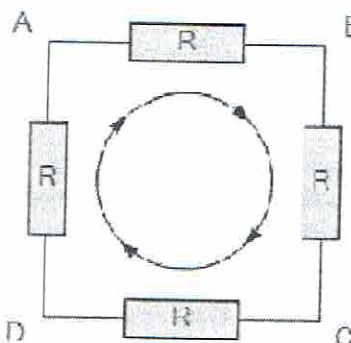

$$V_{AB} + V_{BC} + V_{CD} + V_{DA} = 0$$

Starting at any point in the loop continue in the **same direction** noting the direction of all the voltage drops, either positive or negative, and returning back to the same starting point. It is important to maintain the same direction either clockwise or anti-clockwise or the final voltage sum will not be equal to zero. We can use Kirchoff's voltage law when analyzing series circuits.

When analyzing either DC circuits or AC circuits using **Kirchoff's Circuit Laws** a number of definitions and terminologies are used to describe the parts of the circuit being analyzed such as: node, paths, branches, loops and meshes. These terms are used frequently in circuit analysis so it is important to understand them.

1. **Circuit** - a circuit is a closed loop conducting path in which an electrical current flows.
2. **Path** - a line of connecting elements or sources with no elements or sources included more than once.
3. **Node** - a node is a junction, connection or terminal within a circuit were two or more circuit elements are connected or joined together giving a connection point between two or more branches. A node is indicated by a dot.
4. **Branch** - a branch is a single or group of components, such as resistors, that are connected between two nodes.
5. **Loop** - a loop is a simple closed path in a circuit in which no circuit element or node is encountered more than once.
6. **Mesh** - a mesh is a single open loop that does not have a closed path. No components are inside a mesh.
7. Components are connected in series if they carry the same current.
8. Components are connected in parallel if the same voltage is across them.

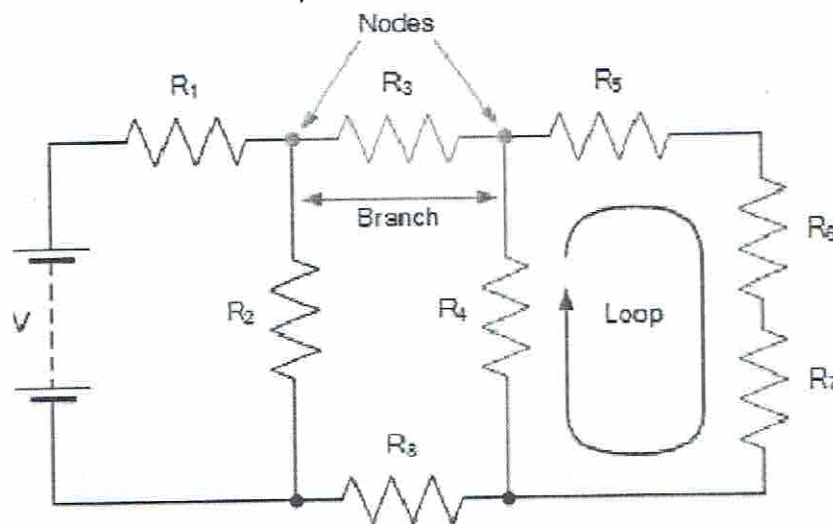

Example 7.1**Required:**

Find the current flowing in the 40Ω Resistor, R_3

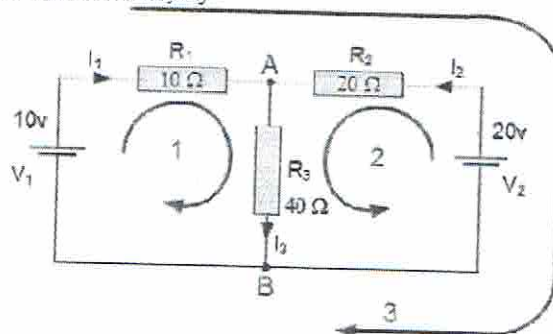
**Solution:**

The circuit has 3 branches, 2 nodes (A and B) and 2 independent loops.

Using **Kirchhoff's Current Law, KCL** the equations are given as:

- At node A: $I_1 + I_2 = I_3$
- At node B: $I_3 = I_1 + I_2$

Using **Kirchhoff's Voltage Law, KVL** the equations are given as:

- Loop 1 is given as: $10 = R_1 \times I_1 + R_3 \times I_3 = 10I_1 + 40I_3$
- Loop 2 is given as: $20 = R_2 \times I_2 + R_3 \times I_3 = 20I_2 + 40I_3$
- Loop 3 is given as: $10 - 20 = 10I_1 - 20I_2$

As I_3 is the sum of $I_1 + I_2$ we can rewrite the equations as;

- Eq. No 1: $10 = 10I_1 + 40(I_1 + I_2) = 50I_1 + 40I_2$
- Eq. No 2: $20 = 20I_2 + 40(I_1 + I_2) = 40I_1 + 60I_2$

We now have two "**Simultaneous Equations**" that can be reduced to give us the value of both I_1 and I_2

- Substitution of I_1 in terms of I_2 gives us the value of $I_1 = -0.143$ Amps
- Substitution of I_2 in terms of I_1 gives us the value of $I_2 = +0.429$ Amps

As: $I_3 = I_1 + I_2$

- The current flowing in resistor R_3 is given as: $I_3 = -0.143 + 0.429 = 0.286$ Amps
- And the voltage across the resistor R_3 is given as: $V_3 = 0.286 \times 40 = 11.44$ volts

The negative sign for I_1 means that the direction of current flow initially chosen was wrong, but never the less still valid. In fact, the 20v battery is charging the 10v battery.

Application of Kirchhoff's Circuit Laws

These two laws enable the Currents and Voltages in a circuit to be found, i.e., the circuit is said to be "Analyzed", and the basic procedure for using **Kirchhoff's Circuit Laws** is as follows:

1. Assume all voltages and resistances are given. (If not, label them $V_1, V_2, \dots, R_1, R_2$, etc.)
2. Label each branch with a branch current. (I_1, I_2, I_3 etc.)
3. Find Kirchhoff's first law equations for each node.
4. Find Kirchhoff's second law equations for each of the independent loops of the circuit.
5. Use Linear simultaneous equations as required to find the unknown currents.

Example 7.2

(Source: <http://www.pa.msu.edu/courses/1997spring/phy232/lectures/kirchoff/examples.html>)

Problem:

Find the currents through all the resistors in the circuit below:

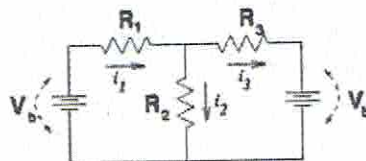

DATA: $V_b = 12 \text{ V}$, $R_1 = 10 \text{ W}$, $R_2 = 15 \text{ W}$, $R_3 = 20 \text{ W}$

Solution:

Summing the voltages around the left and right loops gives the following two equations:

$$1. V_b = i_1 R_1 + i_2 R_2$$

$$2. V_b = i_2 R_2 - (i_1 - i_2) R_3$$

where i_3 has been replaced by $i_1 - i_2$. Multiplying Eq. (1) by R_3 , multiplying Eq. (2) by R_1 , then adding the equations yields:

$$(R_3 + R_1)V_b = i_2(R_3 R_2 + R_1 R_3 + R_2 R_1)$$

which rearranged yields

$$i_2 = \frac{(R_3 + R_1)V_b}{R_3 R_2 + R_1 R_3 + R_2 R_1}$$

Once i_2 is known, Eq. (1) can be used to get i_1 , and i_3 can be found as the difference $i_1 - i_2$.

$$i_2 = 0.554 \text{ amps}, i_1 = .369 \text{ amps}, i_3 = -.185 \text{ amps}$$

Example 7.3

(Source: <http://www.pa.msu.edu/courses/1997spring/phy232/lectures/kirchoff/examples.html>)

Problem:

Find the charges on all the capacitors in the circuit below:

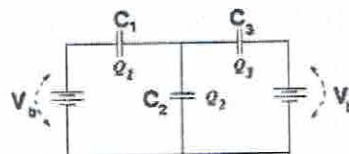

DATA: $V_b = 12 \text{ V}$, $C_1 = 10 \text{ mF}$, $C_2 = 15 \text{ mF}$, $C_3 = 20 \text{ mF}$

Solution:

Summing the voltages around the left and right loops gives the following two equations

$$1. V_b = \frac{Q_1}{C_1} + \frac{Q_2}{C_2}$$

$$2. V_b = \frac{-(Q_1 - Q_2)}{C_3} + \frac{Q_2}{C_2}$$

where Q_3 has been replaced by $Q_1 - Q_2$. Dividing Eq. (1) by C_3 , dividing Eq. (2) by C_1 , then adding the equations yields:

$$V_b \left(\frac{1}{C_1} + \frac{1}{C_3} \right) = Q_2 \left(\frac{1}{C_1 C_2} + \frac{1}{C_2 C_3} + \frac{1}{C_1 C_3} \right)$$

which rearranged yields

$$Q_2 = V_b \frac{C_1 C_3 + C_1 C_2}{C_1 + C_2 + C_3}$$

Once Q_2 is known, Eq. (1) can be used to get Q_1 , and Q_3 can be found as the difference $Q_1 - Q_2$.

Example 7.4

(Source: <http://www.pa.msu.edu/courses/1997spring/phy232/lectures/kirchoff/examples.html>)

The circuit below has been in position *a* for a long time. At time $t = 0$ the switch is thrown to position *b*. DATA: $V_b = 12\text{ V}$, $C = 10\text{ mF}$, $R = 20\text{ W}$

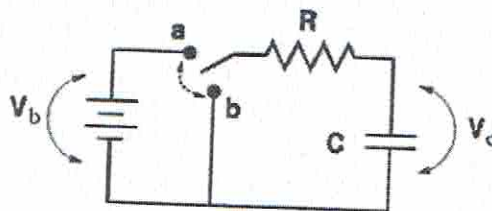

a.) What is the current through the resistor just BEFORE the switch is thrown?

$$I = 0$$

b.) What is the current through the resistor just AFTER the switch is thrown?

Solution: $I = V/R$

$$I = 0.6\text{ amps}$$

c.) What is the charge across the capacitor just BEFORE the switch is thrown?

Solution: $Q = CV$

$$Q = 120\text{ mC}$$

d.) What is the charge on the capacitor just AFTER the switch is thrown?

Solution: Charge does not change instantaneously.

$$Q = 120\text{ mC}$$

e.) What is the charge on the capacitor at at time $t = 0.3\text{ msec}$ after the switch is thrown?

Solution: $Q = Q_0 \exp(-t/\tau)$, where $\tau = RC = 0.2\text{ msec}$

$$Q = 26.8\text{ mC}$$

Example 7.5

(Source: <http://www.pa.msu.edu/courses/1997spring/phy232/lectures/kirchoff/examples.html>)

Considering the same circuit, only with the switch thrown from *b* to *a* at time $t = 0$ after having been in position *b* for a long time. DATA: $V_b = 12\text{ V}$, $C = 10\text{ mF}$, $R = 20\text{ W}$

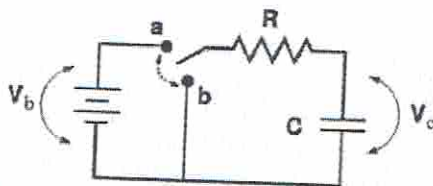

a.) What is the current through the resistor just BEFORE the switch is thrown?

$$I = 0$$

b.) What is the current through the resistor just AFTER the switch is thrown?

Solution: $I = V/R$

$$I = 0.6\text{ amps}$$

c.) What is the charge across the capacitor just BEFORE the switch is thrown?

Solution: $Q = CV$

$$Q = 0$$

d.) What is the charge on the capacitor just AFTER the switch is thrown?

Solution: Charge does not change instantaneously.

$$Q = 0$$

e.) What is the charge on the capacitor at at time $t = 0.3\text{ msec}$ after the switch is thrown?

Solution: $Q = Q_0(1.0 - \exp(-t/\tau))$, where $\tau = RC = 0.2\text{ msec}$

$$Q = 93.2\text{ mC}$$

Topic 8: Magnetic Fields and Forces

(From: *Physics for Scientists and Engineers* by Serway and Jewett, 7th ed., Chapter 29)

8.1 Motion of a Charged Particle in a Uniform Magnetic Field

If a charged particle moves in a uniform magnetic field so that its initial velocity is perpendicular to the field, the particle moves in a circle, the plane of which is perpendicular to the magnetic field. The radius of the circular path is:

$$r = \frac{mv}{qB}$$

where m is the mass of the particle and q is its charge. The angular speed of the charged particle is

$$\omega = \frac{qB}{m}$$

When a particle with charge q and moving with velocity \vec{v} is placed in a magnetic field \vec{B} , it experiences a magnetic force given by

$$\vec{F}_B = q\vec{v} \times \vec{B}$$

The direction of this magnetic force is perpendicular both to the velocity of the particle and to the magnetic field. The magnitude of this force is

$$F_B = |q|vB\sin\theta$$

where θ is the smaller angle between \vec{v} and \vec{B} . The SI unit of B is the tesla (T), where $1 \text{ T} = 1 \text{ N/A} \cdot \text{m}$.

8.2 Magnetic Force Acting on a Current-Carrying Conductor

If a straight conductor of length L carries a current I , the force exerted on that conductor when it is placed in a uniform magnetic field \vec{B} is

$$\vec{F}_b = I\vec{L} \times \vec{B}$$

where the direction of \vec{L} is in the direction of the current and $|\vec{L}| = L$.

If an arbitrarily shaped wire carrying a current I is placed in a magnetic field, the magnetic force exerted on a very small segment $d\vec{s}$ is

$$d\vec{F}_b = Id\vec{s} \times \vec{B}$$

To determine the total magnetic force on the wire, one must integrate the equation over the wire, keeping in mind that both \vec{B} and $d\vec{s}$ may vary at each point.

8.3 Torque on a Current Loop in a Uniform Magnetic Field

The torque $\vec{\tau}$ on a current loop placed in a uniform magnetic field \vec{B} is

$$\vec{\tau} = \vec{\mu} \times \vec{B}$$

The potential energy of the system of a magnetic dipole in a magnetic field is

$$U_B = -\vec{\mu} \cdot \vec{B}$$

Example 8.1

The magnetic field of the Earth at a certain location is directed vertically downward and has a magnitude of $60.0 \mu\text{T}$. A proton is moving horizontally toward the west in this field with a speed of $6.00 \times 10^6 \text{ m/s}$.

- (a) What are the direction and magnitude of the magnetic force exerted by the field on this particle?
 (b) What is the radius of the circular arc followed by this proton?

Solution:

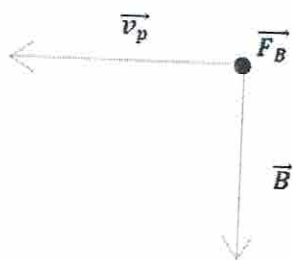

$$\vec{B} = 60.0 \mu\text{T}$$

$$\vec{v}_p = 6.00 \times 10^6 \text{ m/s}$$

$$(a) F_B = |q|vB\sin\theta; \quad \theta = 90^\circ$$

$$F_B = qvB = (1.6 \times 10^{-19} \text{ C}) (6.00 \times 10^6 \frac{\text{m}}{\text{s}}) (60.0 \mu\text{T}) = 5.76 \times 10^{-17} \text{ N}$$

The direction of the magnetic force is south.

$$(b) \vec{F}_B = \vec{F}_{ac} = \frac{mv^2}{r} \rightarrow 5.76 \times 10^{-17} \text{ N} = \frac{(1.67 \times 10^{-27} \text{ kg})(6.00 \times 10^6 \frac{\text{m}}{\text{s}})^2}{r} \rightarrow r = 1.04 \text{ m}$$

Example 8.2

A particle with positive charge $q = 5.00 \times 10^{-19} \text{ C}$ moves with a velocity $\vec{v} = (3\mathbf{i} + 4\mathbf{j} - \mathbf{k}) \text{ m/s}$ through a region where both a uniform magnetic field and a uniform electric field exist. If $\vec{B} = (3\mathbf{i} + 5\mathbf{j} + \mathbf{k}) \text{ T}$ and $\vec{E} = (5\mathbf{i} - \mathbf{j} - 3\mathbf{k}) \text{ V/m}$,

- (a) Compute the total force on the moving particle (in $\mathbf{i}, \mathbf{j}, \mathbf{k}$ notation).
 (b) What angle does the force vector make with the positive x axis?

Solution:

$$(a) \sum \vec{F} = \vec{F}_E + \vec{F}_B = q\vec{E} + q\vec{v} \times \vec{B}$$

$$= 5.00 \times 10^{-19} [(5\mathbf{i} - \mathbf{j} - 3\mathbf{k}) + (3\mathbf{i} + 4\mathbf{j} - \mathbf{k}) \times (3\mathbf{i} + 5\mathbf{j} + \mathbf{k})]$$

$$\vec{v} \times \vec{B} = \begin{vmatrix} \mathbf{i} & \mathbf{j} & \mathbf{k} \\ 3 & 4 & -1 \\ 3 & 5 & 1 \end{vmatrix} = \begin{bmatrix} 4 & -1 \\ 5 & 1 \end{bmatrix} \mathbf{i} - \begin{bmatrix} 3 & -1 \\ 3 & 1 \end{bmatrix} \mathbf{j} + \begin{bmatrix} 3 & -1 \\ 3 & 1 \end{bmatrix} \mathbf{k} = 9\mathbf{i} - 6\mathbf{j} + 3\mathbf{k}$$

$$\sum \vec{F} = (5.00 \times 10^{-19} \text{ C}) [(5\mathbf{i} - \mathbf{j} - 3\mathbf{k}) + (9\mathbf{i} - 6\mathbf{j} + 3\mathbf{k})]$$

$$= (5.00 \times 10^{-19} \text{ C}) [(14\mathbf{i} - 7\mathbf{j}) \text{ N/C}]$$

$$= (7.0\mathbf{i} - 3.5\mathbf{j}) \times 10^{-18} \text{ N}$$

$$(b) \tan\theta = \frac{3.5}{7} = 26.6^\circ$$

Topic 9: Sources of the Magnetic Field

(From: *Physics for Scientists and Engineers* by Serway and Jewett, 7th ed., Chapter 30)

9.1 The Biot-Savart Law

The magnetic flux Φ_B through a surface is defined by the surface integral

$$\Phi_B = \int \vec{B} \cdot d\vec{A}$$

The SI unit of magnetic flux is the weber (Wb): $1 \text{ Wb} = 1 \text{ T} \cdot \text{m}^2$

The Biot-Savart law says that the magnetic field $d\vec{B}$ at a point P due to a length element ds that carries a steady current I is

$$\vec{B} = \frac{\mu_0}{4\pi} \frac{I d\vec{s} \times \hat{r}}{r^2}$$

where μ_0 is the permeability of free space, r is the distance from the element to the point P, and \hat{r} is a unit vector pointing from ds toward point P. We find the total field at P by integrating this expression over the entire current distribution.

9.2 The Magnetic Force Between Two Parallel Conductors

The magnetic force per unit length between two parallel wires separated by a distance a and carrying currents I_1 and I_2 has a magnitude

$$\frac{F_B}{l} = \frac{\mu_0 I_1 I_2}{2\pi a}$$

The force is attractive if the currents are in the same direction and repulsive if they are in opposite directions.

Example 9.1

(Source: <http://www.phys.ttu.edu/~huang24/Teaching/Phys2401/LectureNotes/Chapter30.pdf>)

Example: A thin, straight wire carrying a constant current I . Calculate the total magnetic field at point P.

Solution: Using the Right-Hand Rule, direction of the field at P is into the paper.

$$r = \sqrt{s^2 + R^2}$$

$$\sin \theta = \sin(\pi - \theta) = \frac{R}{\sqrt{s^2 + R^2}}$$

$$B = 2 \times \frac{\mu_0 I}{4\pi} \int_0^\infty \frac{R ds}{(s^2 + R^2)^{3/2}}$$

$$= \frac{\mu_0 I}{2\pi R} \left[\frac{s}{(s^2 + R^2)^{1/2}} \right]_0^\infty$$

$$B = \frac{\mu_0 I}{2\pi R} \propto \frac{1}{R}$$

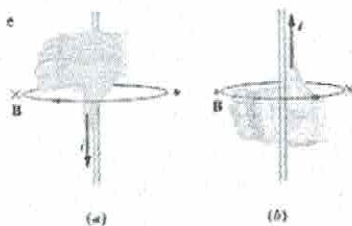
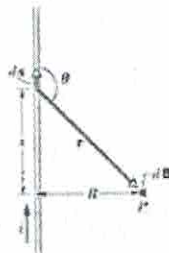

Important Result:

- (1) The magnetic field lines generated by a long straight current-carrying wire are circles concentric with the wire and lie in planes perpendicular to the wire.
- (2) The direction of the field can be determined by a Right-hand rule.
- (3) The magnitude of the magnetic field decreases with the increase of the distance from the

Topic 10: Faraday's Law

(From: *Physics for Scientists and Engineers* by Serway and Jewett, 7th ed., Chapter 31)

10.1 Faraday's Law of Induction

Faraday's Law of Induction states that the induced emf's in a coil is proportional to the negative of the rate of change of magnetic flux:

$$\varepsilon = -\frac{d\phi_B}{dt}$$

For a coil that consists of N loops, the total induced emf would be N ' times as large:

$$\varepsilon = -N' \frac{d\phi_B}{dt}$$

Lenz's LAW ← → # of loops

10.2 Lenz's Law

Lenz's law determines the direction of the induced current. The induced current produces magnetic fields that tend to oppose the change in magnetic flux that induces such currents.

Example 10.1

A toroid having a rectangular cross section ($a = 2.50$ cm by $b = 3.30$ cm) and inner radius $R = 4.40$ cm consists of $N = 600$ turns of wire that carry a sinusoidal current $I = I_{max} \sin \omega t$, with $I_{max} = 60.0$ A and a frequency $f = \omega/2\pi = 70.0$ Hz. A coil that consists of $N' = 20$ turns of wire is wrapped around one section of the toroid as shown. Determine the emf induced in the coil as a function of time.

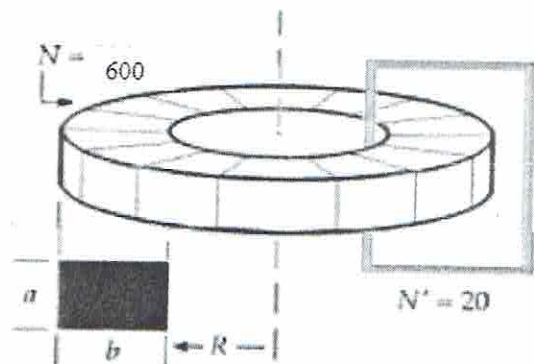

$$\begin{aligned} \varepsilon &= N' \frac{d\phi_B}{dt} = 20 \left[\frac{60^0 \mu_0 I_{max}^x}{2\pi} \right] \omega a \ln \left[\frac{b+R}{R} \right] \cos^s \omega t \\ &= 20 \left[\frac{60^0 \mu_0 I_{max}^x}{2\pi} \right] \omega a \ln \left[\frac{b+R}{R} \right] \cos^s \omega t \end{aligned}$$

As we found in example 9.1, the magnetic field due to a current-carrying wire at a distance r away is

$$B = \frac{\mu_0 I}{2\pi r}$$

For 600 turns, $B = \frac{60^0 \mu_0 I}{2\pi r}$

$$B = \frac{60^0 \mu_0 I_{max}^x \sin \omega t}{2\pi r}$$

$$B = \frac{60^0 \mu_0 I_{max}^x \sin \omega t}{2\pi r}$$

$$\Phi_B = \int B dA = \frac{60^0 \mu_0 I_{max}^x \sin \omega t}{2\pi} \int \frac{a dr}{r}$$

$$\Phi_B = \frac{60^0 \mu_0 I_{max}^x}{2\pi} a \sin \omega t \ln \left[\frac{b+R}{R} \right]$$

$$= 20 \left[\frac{60^0 \left(4\pi \times \frac{10^{-7} N}{A^2} \right) (60 A)}{2\pi} \right] \left(44^0 \frac{rad}{s} \right) (0.02^5 m) \ln \left[\frac{0.03^3 m + 0.04^0 m}{0.04^0 m} \right] \cos^s \omega t = (-0.95^3 V) \cos^s \omega t$$

Faraday's Law

Example 10.2

Source: <http://web.mit.edu/viz/EM/visualizations/coursenotes/modules/guide10.pdf>

An infinite straight wire carries a current I is placed to the left of a rectangular loop of wire with width w and length l , as shown in the Figure 10.9.1. **important*

$\Phi_B = BA \cos \theta$
 $\epsilon = - \frac{d\Phi_B}{dt} = - \frac{d}{dt} (BA \cos \theta)$

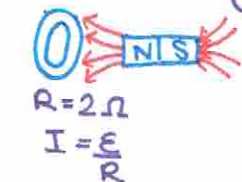

not the existence of magnetic field. It's the rate of change of magnetic field creating current



① $\epsilon = A \cos \theta \frac{dB}{dt}$
 ② $\epsilon = B \cos \theta \frac{dA}{dt}$
 ③ $\theta = \omega t$ $\epsilon = BA \frac{d}{dt} \cos \omega t = -BA \omega \sin \omega t$

Figure 10.9.1 Rectangular loop near a wire

To induce electricity
 ① moving magnetic
 ←, → change B

② change in A

③ rotate disk

LENZ LAW

The induced magnetic field is opposite of the change in magnetic flux

(a) Determine the magnetic flux through the rectangular loop due to the current I .

(b) Suppose that the current is a function of time with $I(t) = a + bt$, where a and b are positive constants. What is the induced emf in the loop and the direction of the induced current?

EXAMPLE
 $R = 5 \Omega$
 $B(t) = 2e^{2t} + 7t + 10$

Solutions:

$R = 50 \text{ cm (radius)}$
 (a) Using Ampere's law:

EXAMPLE
 $B_i = 100 \text{ T}$ $B_f = 0$ $\Delta t = 3 \times 10^{-3} \text{ s}$
 $\frac{dB}{dt} = \frac{\Delta B}{\Delta t} = \frac{B_f - B_i}{\Delta t} = \frac{100}{3 \times 10^{-3}}$

the magnetic field due to a current-carrying wire at a distance r away is

EXAMPLE
 initial final $\frac{dA}{dt} = \frac{\Delta A}{\Delta t}$ $B = \frac{\mu_0 I}{2\pi r}$
 $A_i = \pi r^2$ $A_f = 0$ $\Delta t = 3 \times 10^{-3} \text{ s}$ (10.9.2)

The total magnetic flux Φ_B through the loop can be obtained by summing over contributions from all differential area elements $dA = l dr$:

induced current magnetic field
 $\Phi_B = \int d\Phi_B = \int \mathbf{B} \cdot d\mathbf{A} = \frac{\mu_0 I l}{2\pi} \int_s^{s+w} \frac{dr}{r} = \frac{\mu_0 I l}{2\pi} \ln \left(\frac{s+w}{s} \right)$ (10.9.3)

Note that we have chosen the area vector to point into the page, so that $\Phi_B > 0$.

(b) According to Faraday's law, the induced emf is

$\epsilon = - \frac{d\Phi_B}{dt} = - \frac{d}{dt} \left[\frac{\mu_0 I l}{2\pi} \ln \left(\frac{s+w}{s} \right) \right] = - \frac{\mu_0 l}{2\pi} \ln \left(\frac{s+w}{s} \right) \cdot \frac{dI}{dt} = - \frac{\mu_0 b l}{2\pi} \ln \left(\frac{s+w}{s} \right)$ (10.9.4)

where we have used $dI/dt = b$.

The straight wire carrying a current I produces a magnetic flux into the page through the rectangular loop. By Lenz's law, the induced current in the loop must be flowing counterclockwise in order to produce a magnetic field out of the page to counteract the increase in inward flux.

what happens if the magnet passes through disk

As magnet approaches, magnetic flux ↓ ∴ current counter other side of disk, a magnet leaves, magnetic flux ↑ ∴ current clockwise

Topic 11: Inductance

(From: Physics for Scientists and Engineers by Serway and Jewett, 7th ed., Chapter 32)

11.1 Self-Induction and Inductance

When the magnetic field generated by a coil changes with time (due to a change in current) the magnetic flux enclosed by the coil will also change. This change in flux will induce an emf in the coil, and since the emf is due to a change in the current through the coil it is called the self-induced emf. The self-induced emf is equal to

$$EMF = -L \frac{di}{dt}$$

L is called the self-inductance of the coil. The self-induced emf will act in such a direction to oppose the change in the current.

11.2 RL Circuits

An RL circuit consists of a resistor and an inductor placed in series with a battery (see Figure 32.4). Applying Krichhoff's second rule to this single-loop circuit we obtain the following differential equation

$$-iR + E - L \frac{di}{dt} = 0$$

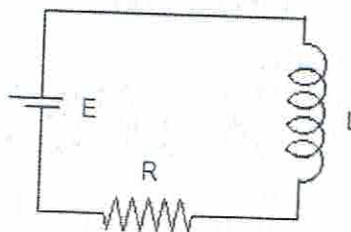

The RL circuit.

This differential equation has as a solution

$$i = \frac{E}{R} \left(1 - e^{-\frac{Rt}{L}} \right)$$

This solution is valid if the battery is connected at $t = 0$. Equation (32.51) shows that the current at $t = 0$ s is equal to 0 and grows steadily to reach a final value of E/R at $t = [\text{infinity}]$. The time constant of the RL circuit is L/R . If the current has reached a steady value and the battery is suddenly disconnected, the conductor can generate a current through the resistor that will gradually decay as function of time. If the initial current is equal to i , the current at time t will be equal to

$$i = \frac{E}{R} e^{-\frac{Rt}{L}}$$

Ampere's Law
 $B = \frac{\mu_0 I}{2\pi r}$
 infinite straight
 $r = 30 \text{ cm}$
 $I = 5 \text{ A}$

when asked to find carrying current inside

$$\mu_0 I_{in} = \oint \vec{B} \cdot d\vec{s}$$

$$B = \frac{\mu_0 I_{in}}{2\pi r}$$

when $r > R$
 $I_{in} = I_T$
 when $r < R$
 $I_{in} = \text{fraction } I_T$ (follows ratio)

$$\frac{\pi r^2}{\pi R^2}$$

$$\therefore I_{in} = \frac{r^2}{R^2} I_T$$

Example 11.1

(Source: <http://phys.lsu.edu/~jdownling/PHYS21024SP07/lectures/lecture19.pdf>)

$$B_{inside} = \frac{\mu_0 (r^2/R^2) I_T}{2\pi r}$$

- The current in a 10 H inductor is decreasing at a steady rate of 5 A/s.
- If the current is as shown at some instant in time, what is the magnitude and direction of the induced EMF?

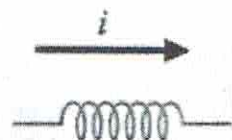

- (a) 50 V \longrightarrow
 (b) 50 V \longleftarrow

- Magnitude = $(10 \text{ H})(5 \text{ A/s}) = 50 \text{ V}$
- Current is decreasing
- Induced emf must be in a direction that **OPPOSES** this change.
- So, induced emf must be in same direction as current

Example 11.2

(Source: <http://phys.lsu.edu/~jdowning/PHYS21024SP07/lectures/lecture19.pdf>)

Immediately after the switch is closed, what is the potential difference across the inductor?

- (a) 0 V
 (b) 9 V
 (c) 0.9 V

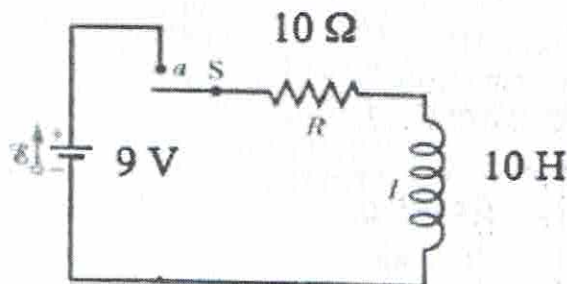

- Immediately after the switch, current in circuit = 0.
- So, potential difference across the resistor = 0!
- So, the potential difference across the inductor = $\mathcal{E} = 9 \text{ V}$!

Example 11.3

(Source: <http://phys.lsu.edu/~jdowning/PHYS21024SP07/lectures/lecture19.pdf>)

q) $\mathcal{E} = 3V$  $I = \frac{3}{10} = 0.3$

Example

a) • Immediately after the switch is closed, what is the current i through the 10Ω resistor?

- (a) 0.375 A
- (b) 0.3 A**
- (c) 0

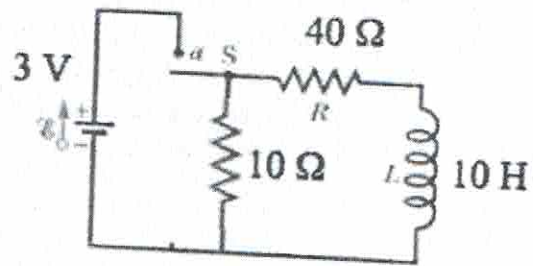

- Immediately after switch is closed, current through inductor = 0.
- Hence, current through battery and through 10Ω resistor is $i = (3V)/(10\Omega) = 0.3A$

b) • Long after the switch has been closed, what is the current in the 40Ω resistor?

- (a) 0.375 A
- (b) 0.3 A
- (c) 0.075 A

- Long after switch is closed, potential across inductor = 0.
- Hence, current through 40Ω resistor = $(3V)/(40\Omega) = 0.075A$

*cell phone \rightarrow Plug (slowly charge)
 resistor-capacitor \rightarrow unplug (slowly discharge)
RC circuits
 relationship with +time

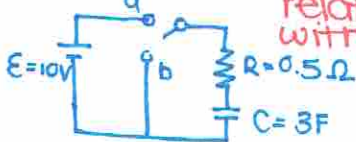

switch a: (charging) 

switch b: (discharging) 

$q(t) = C\mathcal{E}(1 - e^{-t/RC})$ $I = \frac{dq}{dt} = I(t) = \frac{\mathcal{E}}{R} e^{-t/RC}$

$q(t) = C\mathcal{E}e^{-t/RC}$ $I = \frac{dq}{dt} = I(t) = -\frac{\mathcal{E}}{R} e^{-t/RC}$

RL Circuits

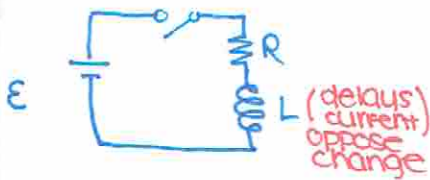

switch on: $i(t) = \frac{\mathcal{E}}{R} e^{-t/\tau}$

switch off: $i(t) = \frac{\mathcal{E}}{R} (1 - e^{-t/\tau})$

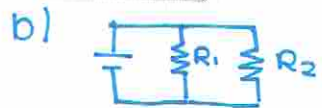

$R_{eq} = (\frac{1}{R_1} + \frac{1}{R_2})^{-1} = (\frac{1}{10} + \frac{1}{40})^{-1}$

$R_{eq} = \frac{400}{50} = 800$

$I_1 = 0.8 (\frac{3}{8}) =$

$I_2 = 0.2 (\frac{3}{8}) =$

$\tau = \frac{L}{R}$

Topic 12: Alternating Current Circuits

(From: *Physics for Scientists and Engineers* by Serway and Jewett, 7th ed., Chapter 33)

- In an AC circuit with a sinusoidal voltage source $V(t) = V_0 \sin \omega t$, the current is given by $I(t) = I_0 \sin(\omega t - \phi)$, where I_0 is the amplitude and ϕ is the phase constant. For simple circuit with only one element (a resistor, a capacitor or an inductor) connected to the voltage source, the results are as follows:

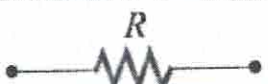
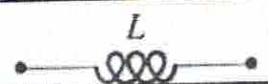
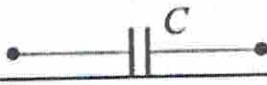
Circuit Elements	Resistance /Reactance	Current Amplitude	Phase angle ϕ
	R	$I_{R0} = \frac{V_0}{R}$	0
	$X_L = \omega L$	$I_{L0} = \frac{V_0}{X_L}$	$\pi/2$ current lags voltage by 90°
	$X_C = \frac{1}{\omega C}$	$I_{C0} = \frac{V_0}{X_C}$	$-\pi/2$ current leads voltage by 90°

where X_L is the inductive reactance and X_C is the capacitive reactance.

- For circuits which have more than one circuit element connected in series, the results are

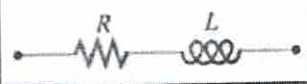
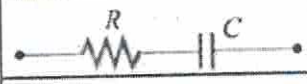
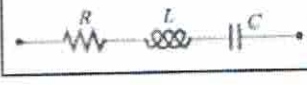
Circuit Elements	Impedance Z	Current Amplitude	Phase angle ϕ
	$\sqrt{R^2 + X_L^2}$	$I_0 = \frac{V_0}{\sqrt{R^2 + X_L^2}}$	$0 < \phi < \frac{\pi}{2}$
	$\sqrt{R^2 + X_C^2}$	$I_0 = \frac{V_0}{\sqrt{R^2 + X_C^2}}$	$-\frac{\pi}{2} < \phi < 0$
	$\sqrt{R^2 + (X_L - X_C)^2}$	$I_0 = \frac{V_0}{\sqrt{R^2 + (X_L - X_C)^2}}$	$\phi > 0$ if $X_L > X_C$ $\phi < 0$ if $X_L < X_C$

where Z is the impedance Z of the circuit. For a series RLC circuit, we have

$$Z = \sqrt{R^2 + (X_L - X_C)^2}$$

The phase angle between the voltage and the current in an AC circuit is

$$\phi = \tan^{-1} \left(\frac{X_L - X_C}{R} \right)$$

Example 12.1

(Source: <http://web.mit.edu/viz/EM/visualizations/coursenotes/modules/guide12.pdf>)

Suppose an AC generator with $V(t) = (150\text{ V})\sin(100t)$ is connected to a series RLC circuit with $R = 40.0\ \Omega$, $L = 80.0\ \text{mH}$, and $C = 50.0\ \mu\text{F}$, as shown in Figure 12.9.1.

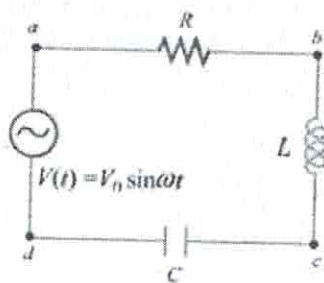

Figure 12.9.1 RLC series circuit

- (a) Calculate V_{R0} , V_{L0} and V_{C0} , the maximum of the voltage drops across each circuit element.
- (b) Calculate the maximum potential difference across the inductor and the capacitor between points b and d shown in Figure 12.9.1.

Solutions:

- (a) The inductive reactance, capacitive reactance and the impedance of the circuit are given by

$$X_C = \frac{1}{\omega C} = \frac{1}{(100\ \text{rad/s})(50.0 \times 10^{-6}\ \text{F})} = 200\ \Omega \quad (12.9.7)$$

$$X_L = \omega L = (100\ \text{rad/s})(80.0 \times 10^{-3}\ \text{H}) = 8.00\ \Omega \quad (12.9.8)$$

and

$$Z = \sqrt{R^2 + (X_L - X_C)^2} = \sqrt{(40.0\ \Omega)^2 + (8.00\ \Omega - 200\ \Omega)^2} = 196\ \Omega \quad (12.9.9)$$

respectively. Therefore, the corresponding maximum current amplitude is

$$I_0 = \frac{V_0}{Z} = \frac{150\ \text{V}}{196\ \Omega} = 0.765\ \text{A} \quad (12.9.10)$$

The maximum voltage across the resistance would be just the product of maximum current and the resistance:

$$V_{R0} = I_0 R = (0.765 \text{ A})(40.0 \Omega) = 30.6 \text{ V} \quad (12.9.11)$$

Similarly, the maximum voltage across the inductor is

$$V_{L0} = I_0 X_L = (0.765 \text{ A})(8.00 \Omega) = 6.12 \text{ V} \quad (12.9.12)$$

and the maximum voltage across the capacitor is

$$V_{C0} = I_0 X_C = (0.765 \text{ A})(200 \Omega) = 153 \text{ V} \quad (12.9.13)$$

Note that the maximum input voltage V_0 is related to V_{R0} , V_{L0} and V_{C0} by

$$V_0 = \sqrt{V_{R0}^2 + (V_{L0} - V_{C0})^2} \quad (12.9.14)$$

(b) From b to d , the maximum voltage would be the difference between V_{L0} and V_{C0} :

$$|V_{bd}| = |\vec{V}_{L0} + \vec{V}_{C0}| = |V_{L0} - V_{C0}| = |6.12 \text{ V} - 153 \text{ V}| = 147 \text{ V} \quad (12.9.15)$$

magnetism

magnetic force

Point charge

$$F_B = q\vec{v} \times \vec{B}$$

$$= qvB \sin \theta$$

↑
var d B

wire

$$F_B = I\vec{L} \times \vec{B}$$

$$= ILB \sin \theta$$

↑
I and B



$$F_B = qvB \sin 90$$

$$= qvB$$

$$= (10)(10)(2)$$

$$\vec{F}_B = 2 \times 10^6 \text{ N}$$

$$F_B = ILB \sin 90$$

$$= ILB$$

$$= 2(0.05)(2)$$

$$= 0.2 \text{ N}$$

↑
into the page

* need magnitude + direction (using right-hand rule into the page)

• → into the page × → out of the page
when charge is (-) opposite direction

* two // vector (cross product) = 0
if ⊥ divide into x, y component
⊥ will be 0 due to // and only magnitude will change

* Right hand rule

- fingers direction of velocity / I
- palm flat $\vec{v} \rightarrow \vec{B}$
- thumb direction



magnetic source

$$B = \int dB = \frac{\mu_0 I}{4\pi} \int \frac{d\vec{s} \times \hat{r}}{r^2}$$

↑
unit vector

$$\therefore B = \frac{\mu_0 I}{4\pi} \int \frac{ds \sin \theta}{r^2}$$

↑
cross product of 2 vector
 $d\vec{s} \times \hat{r} = ds \times 1 \times \sin \theta$

↑
angle between ds and r

no length
infinite straight

$$\vec{B} = \frac{\mu_0 I}{2\pi r}$$

↑
circle

$$\vec{B} = \frac{\mu_0 I}{2r}$$

ex:

$B_{\text{center}} = ?$

$$\vec{B} = \frac{\mu_0}{4\pi} I \int \frac{ds \cdot \sin \theta}{r^2}$$

$$\vec{B} = \frac{\mu_0}{4\pi} \frac{I \sin \theta}{r^2} \int ds$$

↑
= S

$$\vec{B} = \frac{\mu_0}{4\pi} \frac{I}{r^2} 2\pi r$$

$$\vec{B} = \frac{\mu_0 I}{2r}$$

Finally find direction

2nd right hand rule

- thumb follows current
- fingers curl around magnetic field

Phys 205, section 03 – Winter 2012

Problem Set #1

Due date: January 18th, 2012

For each problem you must draw a clear diagram detailing the situation!

Grading: Out of 25 points, each problem's weight is indicated. Assignments that are late will be penalized 20% per day that they are late. Late assignments can be slipped under my office door. No homework should be identical, collaborating does not mean copying.

Format: Write your name and ID, my name, "Problem set #1" and the date you turn your homework in at the top of the first page (write the names of people with whom you collaborated on this homework). Zero point will be given for a good answer without the proper intermediate steps. Write clearly and detail (briefly) the logic of the steps that you are using.

Notes: Problems with a * are more challenging and should be answered last. If you find that you can solve all the problems without a *, then you are doing fine. If not, please seek help right away, either via your SL sections, your peers, or my office hours.

Problem 1 (3 points) Adding vector forces in 2-dimensions (x-y plane)

A charged object has two forces acting on it: \vec{F}_1 (4 Newtons, pointing up at 120° from the positive x axis), and \vec{F}_2 (8 Newtons, pointing down -30° from the positive x-axis).

- Write down \vec{F}_1 and \vec{F}_2 in terms of the unit vectors \hat{i} (along x-axis) and \hat{j} (along the y-axis).
- Compute the total (net) force acting on the object and write it down in terms of \hat{i} and \hat{j} .
- Write down the total force in polar form, i.e. give its magnitude (in Newtons) and its orientation (angle from the positive x-axis).

Problem 2 (3 points, (a) 2, (b) 1) Coulomb's Law and Newton's Laws

Consider the three point charges shown below. (a) What is the total electric force \vec{F}_e (magnitude and direction) on charge q_1 ? (b) If these 3 charges are placed in the Earth's gravitational field (use $\vec{g} = -10 \frac{m}{s^2} \hat{j}$), and the mass of charge q_2 is $m_2 = 1$ kg, what is the total acceleration, \vec{a}_2 , of q_2 ?

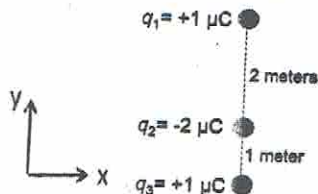

Problem 3 (3 points, (a) 2, (b) 1) Electric field and force from point charges

Four point charges are placed on the corners of a rectangle as shown in the diagram below.

- Determine the electric field (vector) at the location of the charge $-q$.
- Determine the force (vector) on charge $-q$.

Problem 4:

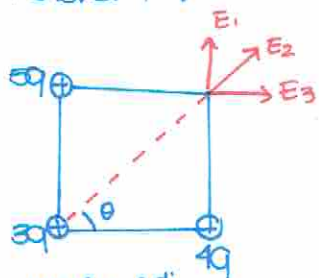

$\cos \theta = \frac{\text{adj}}{\text{hyp}}$

$\sin \theta = \frac{\text{opp}}{\text{hyp}}$

- ① Graph
 sign { ② x-component
 y-component
 ③ use original formula

Ex: Find total potential at position - Q

$$V_T = V_1 + V_2 + V_3$$

$$= \frac{k(4q)}{r} + \frac{k(3q)}{r} + \frac{k(5q)}{r}$$

$$= \frac{kq}{2a} \left(\frac{4}{a} + \frac{3}{a} + \frac{5}{a} \right)$$

Ex: Find the potential energy

$U_e = V_T (-q_0)$ *once it is released at infinite what is the final velocity

$\Delta K + \Delta U = 0$

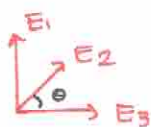

$\vec{E}_T = E_x \hat{i} + E_y \hat{j}$

$\Sigma E_x = E_3 + E_2 \cos \theta = \frac{k(5q)}{(2a)^2} + \frac{k(3q)}{(3a)^2} \cos \theta =$

$\Sigma E_y = E_1 + E_2 \sin \theta = \frac{k(4q)}{(3a)^2} + \frac{k(3q)}{(3a)^2} \sin \theta =$

$E_x = \frac{kq}{a^2} \left(\frac{5}{a} + \frac{6}{\sqrt{13}} \right)$

$E_y = \frac{kq}{a^2} \left(\frac{4}{\sqrt{13}} + \frac{6}{a} \right)$

magnitude
 $\|E\| = \sqrt{E_x^2 + E_y^2}$

direction
 $\theta = \tan^{-1} \left(\frac{E_y}{E_x} \right)$

- ④ simplify
 ⑤ Additional step (magnitude, direction, ect)

start at step 3

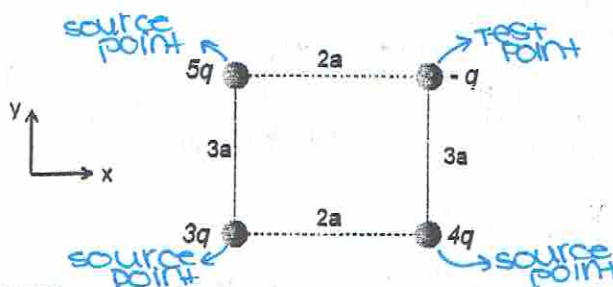

***Problem 4 (3 points) Electric field from a continuous charge distribution**

The figure below represents a uniformly charged solid cylinder (not hollow) with a total charge $-Q$. What is the electric field at the point O which is a distance h above the central axis of the cylinder? (hint: first divide up the cylinder into infinitely thin disks, and then the disks into rings. Find the contribution of one ring, then one disk (see textbook). Then add the contribution of all the disks making up the cylinder, use a table (book) to find the result of the integral!)

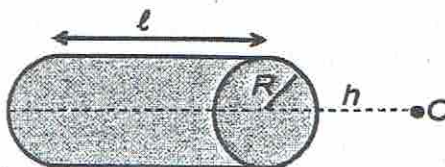

Problem 5 (2 points) Electric field lines

Consider an infinite plane with a uniform negative surface charge density. Draw a cartoon (side view is ok) representing the electric field lines above and below the plane.

Problem 6 (2 points) Motion in a uniform electric field

A negatively charged ball having a mass of 10 grams falls from rest in vacuum from a height of 3 meters in a uniform vertical electric field of 10^4 N/C. The ball hits the ground at a speed of 10 m/s. (a) Is the electric field pointing up or down? (b) What is the charge on the ball?

Problem 7 (2 points) Electric flux

A point charge q is at the middle of a cylindrical box of length a and radius b ($b < a$). The box has a uniform surface charge density σ . What is the electric flux through a cubic box, whose side's length is $2a$, and which is also centered on the point charge q ? (hint: no complicated math is necessary)

Problem 8 (2 points) Gauss' Law - plane

Consider an infinite non-conducting plane (sheet) of charge. The sheet has a uniform charge density $+3\sigma$. (a) Calculate the electric field above and below the plane. (b) If a second plane with the same charge density is placed parallel and a distance d above the first one, what is the electric field between the two planes?

Problem 9 (3 points) Gauss' Law - sphere

Two co-centric hollow spheres have radii of R_1 and R_2 and have uniform surface charge densities σ_1 and σ_2 . The two charge densities are positive. Derive an expression for the electric field (vector) outside the two spheres ($r > R_2$).

Problem 10 (2 points) Gauss' Law - cylinder

An infinite straight wire has a uniform charge density $\lambda = +1 \mu\text{C}/\text{m}$. This wire sits inside and on the axis of a hollow infinite cylinder of 0.5m diameter which has a surface charge density $\sigma = -0.2 \mu\text{C}/\text{m}^2$. What is the electric field 1 meter away from the straight wire?

Q1: Find the total energy
integration

δ = infinitesimal small E

L is a constant
although r can be represented
in terms of x
 $(2L-x)$

charge density λ

EX: $\lambda = \frac{Q_T}{L} = \frac{2C}{5m}$

$$E_T = \int \delta E = \int \frac{k \delta q}{r^2} = \int \frac{k \lambda \cdot dx}{(2L-x)^2}$$

$$= k \lambda \int \frac{dx}{(2L-x)^2} = k \lambda \left[\frac{1}{2L-x} \right]_0^{2L}$$

$$E_T = k \lambda \left(\frac{1}{L} - \frac{1}{2L} \right)$$

Find total potential

$$V_T = \int \frac{kq}{r} = k \lambda \int \frac{dx}{2L-x} = -k \lambda \ln |2L-x| \Big|_0^{2L}$$

$$V_T = -k \lambda (\ln L - \ln(2L)) = -k \lambda \ln \left(\frac{L}{2L} \right) = -k \lambda \ln \left(\frac{1}{2} \right)$$

STEPS

- ① cut into infinitesimal small
- ② find a way to solve r and q
- ③ using integration find relationship of Q^{**}

Q2:



$E = \frac{q_{in}}{A_{eff} \epsilon_0}$

$E = \frac{\delta A_{intersection}}{2 A_{top} \epsilon_0} = \frac{\delta}{2 \epsilon_0}$

$A_{inter.} = A_{top} \Rightarrow$ Prism

$$\Delta V_{A-B} = E d_{A-B}$$

$$U_E = V_{A-B} q_0$$

Phys 205, section 03 – Winter 2012

Problem Set #2

Due date: February 1st

When using the Physics HW drop-box: Do not forget to write the instructor's name and section number.

Grading: Out of 25 points, each problem's weight is indicated. The problem set must be handed-in on the due date. Assignments that are late will be penalized 20% per day that they are late. Late assignments can be slipped under my office door. No homework should be identical, collaborating does not mean copying. Plagiarism is easy to detect.

Format: For each problem you must draw a diagram detailing the situation. Zero point will be given for a good answer without the proper derivation (intermediate steps). Write clearly and detail (very briefly) the logic of the steps that you are using. If I cannot understand what you are doing, you will lose marks.

Notes: Problem with a * are more challenging, but you should at least attempt them to get partial credit. If you find that you can solve all the problems without a *, you are doing fine. If not, please seek help right away, either via tutorials, your peers, or my office hours.

Problem 1 (2 points) Potential energy

Explain why (one sentence + one equation) a force which only changes the direction (angle) of the velocity of an object and not its speed (magnitude) does not perform any work on the object?

Problem 2 (3 points) Potential difference in a uniform electric field

An electron starts at rest in a uniform electric field of $5 \times 10^6 \text{ V/m}$. (a) Through what potential difference has it passed after moving 5 cm? (b) What is its change in potential energy? Give your answer both in units of eV and Joules. (c) What is its velocity after moving 5 cm?

Problem 3 (2 points) Electric potential and electric potential energy due to point charges

Two identical point charges ($q_1 = q_2 = -1 \mu\text{C}$) are located on the x-axis. One is at position $x = +2$ meters, and the other at $x = -1$ meter. (a) Find the electric potential at $x = 0$. (b) Calculate the change in potential energy of the entire system if a third charge ($q_3 = -2 \mu\text{C}$) is brought from infinity to $(x = 0, y = +1\text{m})$.

Problem 4 (3 points) Electric potential from a continuous charge distribution

The figure below represents a uniformly charged cylindrical shell (hollow) with a total charge $-Q$. What is the electric potential at the point O which is a distance h above the central axis of the cylinder? (hint: decompose the cylinder into a stack of rings)

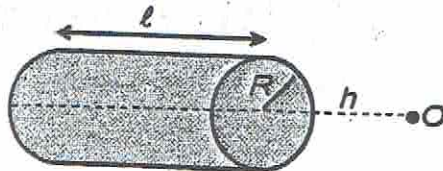

Problem 5 (4 points) Electric potential

- (a) The electric field in a region of space is given by $\vec{E} = (2x + x^2) \hat{i}$ V/m (points along x). Calculate the potential difference ΔV between the positions $x_1 = 1\text{m}$, and $x_2 = 2\text{m}$. Which has a higher potential?
- (b) If $V = 0$ at infinity, what is the potential at point "O", if it sits a distance L above the end of a rod of length L which carries a uniform linear charge density and has a total charge Q ?

$$a) C_{eq} = \left(\frac{1}{3} + \frac{1}{3}\right)^{-1} = \frac{3}{2}$$

$$b) Q_T = C_{eq} \cdot V = \frac{3}{2} (10) = 15 C$$

$$c) \begin{matrix} Q_1 & Q_2 & Q_3 \\ 15 & 10 & 5 \end{matrix}$$

$$d) V_1 = \frac{Q_1}{C_1} \quad V_2 = \frac{Q_2}{C_2} \quad V_3 = \frac{Q_3}{C_3}$$

$$\frac{5}{3} = 5 \quad \frac{10}{2} = 5 \quad \frac{5}{1} = 5$$

* Voltage in // is equivalent.
* Current in series is equiv.

$$e) U_T = \frac{Q_T^2}{2C_{eq}} = \frac{15^2}{2(15)}$$

$$f) U_1 = \frac{Q_1^2}{2C_1}$$

$$U_2 = \frac{Q_2^2}{2C_2}$$

$$U_3 = \frac{Q_3^2}{2C_3}$$



Problem 6 (1 points) Electric field from the electric potential (read section 26.6)

Consider an electric dipole (two point charges of opposite charge) which has a value $p = qd$, where q is the magnitude of the charges and d is the distance between them. You are told that the potential due to a dipole is given by $V = p \cos \theta / (4\pi\epsilon_0 r^2)$. What is the radial component of the electric field (E_r) due to this dipole?

Problem 7 (1 points) Parallel plate capacitor

A parallel plate capacitor is connected to a battery with a potential difference ΔV . If the two plates are brought closer together, the electric field between the plates increases. Explain why (one sentence + one equation).

Problem 8 (2 points) Capacitance

Metallic carbon nanotubes were first discovered about 15 years ago. They are small conducting cylinders made of a wrapped sheet of carbon atoms (one atom-thick). Consider a double-wall carbon nanotubes (two concentric cylinders), were the smallest tube has a radius of 1 nm ($10^{-9}m$) and the larger tube has a radius of 2 nm. Assume that the two shells are infinitely thin and are separated by air. If the tube is 2 μm long, what is the capacitance of this double-wall nanotube? (hint: You do not need to re-derive the expression for the electric field, take it from the book. You do need to derive the expression for the capacitance.)

*** Problem 9 (4 points) Combination of capacitors**

$$V = 10V$$

Consider the circuit below. (a) What is the equivalent capacitance to this circuit of 3 capacitors? (b) Which capacitor is storing the largest charge? (c) Which capacitor has the largest potential difference across it? (d) Which capacitor is storing the largest potential energy in its electric field?

STEPS

- ① simplify graph 1 step at a time
- ② C_{eq}
- ③ Q_T
- ④ individual Q
- ⑤ individual V
- ⑥ U_T
- ⑦ individual U

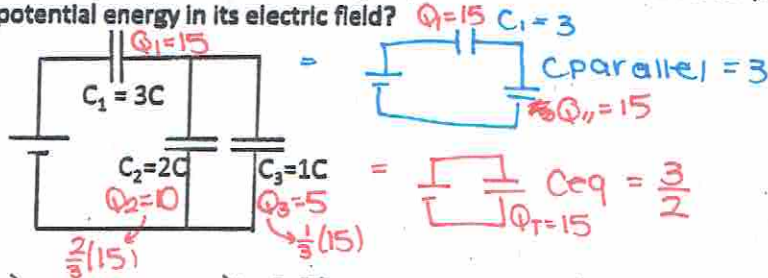

*steps identical for resistors

*** Problem 10 (3 points) Capacitor with dielectrics**

replace Q with I

Consider the parallel plate capacitors show below. (a) Find an expression for its capacitance in terms of the area of the metal electrodes, A , d , ϵ_0 , and $\kappa_1, \kappa_2, \kappa_3$. (b) How much work must be done to remove the block of dielectric κ_2 from between the plates?

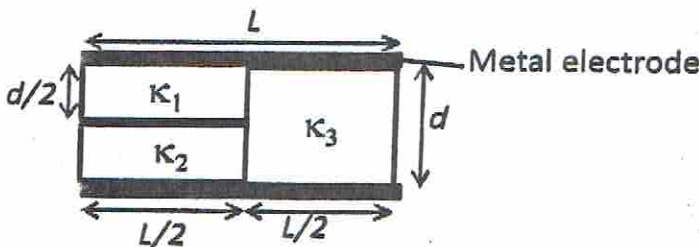

Phys 205, section 03 – Winter 2012

Problem Set #3

Due date: February 15th

Grading: Out of 25 points, each problem's weight is indicated. The problem set must be handed-in on the due date. Assignments that are late will be penalized 20% per day that they are late. Late assignments can be slipped under my office door.

Format: For each problem you must draw a diagram detailing the situation. Zero point will be given for a good answer without the proper derivation (intermediate steps). Write clearly and detail (very briefly) the logic of the steps that you are using. If I cannot understand what you are doing, you will lose marks.

Problem 1 (2 points) Electric current

The quantity of charge q (in Coulombs) passing through a wire of square cross-section (2 cm sides) varies in time and is given by $q(t) = 4\ln(t) + 3t^2$ where t is in seconds ($t \neq 0$). (a) What is the current through the wire at $t=2$ seconds? (b) What is the current density versus time in the wire?

Problem 2 (3 points) Resistance and resistivity

Consider the circuit below. The smaller wires (cylinders) have a radius of 1cm, and the larger one 2cm. All cylinders are 10cm long. (a) If you assume that the thin wires (black lines) are perfect conductors, what is the equivalent resistance across the battery? (hint: look in your textbook for the resistivity of gold and copper, given for $T=20^\circ\text{C}$). (b) What is the equivalent resistance at 200°C ? (use the temperature coefficients from the book)

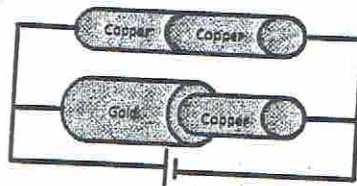

Problem 3 (2 points) Microscopic model of electrical transport

For a metal with a volume density of charge carriers (free electrons) $n = 5 \times 10^{28} \text{ m}^{-3}$, and carrying a current density of 2 A/cm^2 , (a) what is the drift velocity of electrons? (b) If $v_{\text{thermal}} = 10^5 \text{ m/s}$, what is the average kinetic energy transferred by an electron when it collides with an atom? (kinetic energy = $1/2 mv^2$)

Problem 4 (2 points) Power dissipated in a resistor

Assume that the heating element of your stove operates at 240V and carries a current of 5 A. If you use it to heat up one liter of water from 25°C to 100°C and assume that all the heat from the element goes into the water, how much time does it take? (specific heat of water is $4.186 \text{ Joule}/(\text{gram} \cdot ^\circ\text{C})$)

Problem 5 (2 points) Combination of resistors

Consider the circuit below. When the switch is open (as shown) the current in the battery is 1.4 mA, when the switch is in position 1 the current in the battery is 1.6 mA, and when the switch is in position 2, the current is 2.2 mA. What are R_1, R_2, R_3 ?

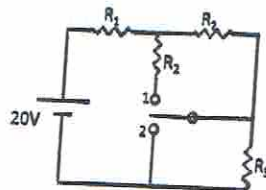

Problem 6 (2 points) Kirchoff's rules I

For the circuit below, (a) What is the current across the 2 Ohm resistor? (b) The potential difference between points a and b?

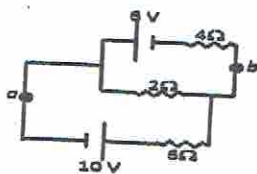

**important*

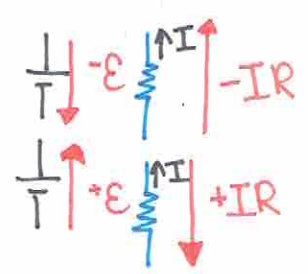

Problem 7 (3 points) Kirchoff's rules II

For the circuit below, (a) find the currents I_1, I_2, I_3 and (b) the potential difference ΔV_{ab} and ΔV_{dc} .

Loop: $I_1 + I_3 = I_2$ (eq'n 1)
battery resistor

Loop 1: $0 - 1000I_1 + 4 - 2000I_2 = 0$ (eq'n 2)
resistor battery resistor

Loop 2: $+2000I_2 - 4 + 3000I_3 = 0$ (eq'n 3)
 $\epsilon_1 = 10V$

Loop 3: $+10 - 1000I_1 + 3000I_3 = 0$ (eq'n 4)

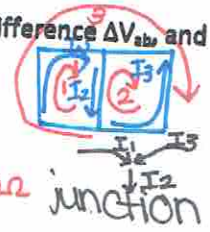
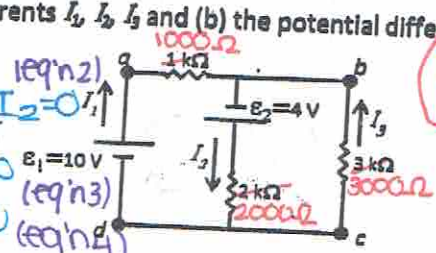

Problem 8 (2 points) RC circuit I

In the circuit below, (a) determine the RC time constant when the switch is open. (b) determine the RC time constant when the switch is closed.

$4 - 1000I_1 - 2000(I_1 + I_3) = 0$

$2000(I_1 + I_3) - 4 + 3000I_3 = 0$

$I_1 = \frac{4 - 5000I_3}{2000}$

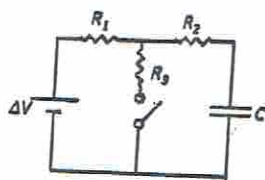

use eq'n 1 sub that into eq'n 2 & 3

$4 - 3000\left(\frac{4 - 5000I_3}{2000}\right) - 2000I_3 = 0$

solve for I_3
solve for I_1
solve for I_2

Problem 9 (2 points) RC circuit II

In the circuit below, no charge is on the two capacitors before the switch is closed. What is the charge (as a function of time) on each of the two capacitors after the switch is closed?

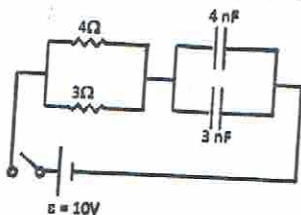

* if answer is (-)
add comment:
in reality current is
in opposite
direction ∴ (+)

Problem 10 (5 points, (a) 2-points, (b) 2 points, (c) 1 point) Mid-term review

A uniformly charged rod of length L with total charge $-Q$ runs along the x-axis as shown below, its end is a distance L away from point O . A uniformly charged semi-circular rod (radius L) with a total charge of $+Q$ is located as shown below; point O is at the center. And a charged sphere of charge $-Q$ has its center a distance $2L$ from O as shown below. (a) What is the electric field (vector) at point O ? (b) What is the electric potential at point O ? (c) If we placed an object with a charge $+Q$ and mass m at point O what would be its acceleration? (hint: solve for the field of each object, then use the superposition principle)

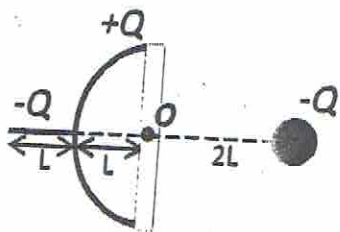

Phys 205, section 03 – Winter 2012

Problem Set #4

Due date: March 7th

Grading: Out of 20 points, each problem's weight is indicated. The problem set must be handed-in on the due date. Assignments that are late will be penalized 20% per day that they are late. Late assignments can be slipped under my office door.

Format: For each problem you must draw a diagram detailing the situation. Zero point will be given for a good answer without the proper derivation (intermediate steps). Write clearly and detail (very briefly) the logic of the steps that you are using. If I cannot understand what you are doing, you will lose marks.

Problem 1 (2 points) Magnetic force 1

An electron moving perpendicular to a magnetic field and along the positive y-direction experiences a magnetic deflection in the +x (positive x) direction. (a) Which way does the magnetic field point? (b) If the magnitude of the magnetic force is $|\vec{F}_B| = 4 \times 10^{-12}$ N and $B = 4$ Tesla, what is the velocity \vec{v} of the electron?

Problem 2 (3 points) Magnetic force 2

An electron a distance $L=1$ m away from an infinite wire (carrying a current $I = 1$ mA = 10^{-3} A) is moving radially outward at a speed $v = 10^7$ m/s. Calculate the magnetic force (vector) on the electron?

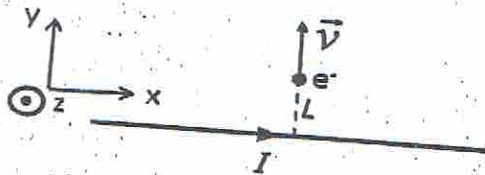

Problem 3 (2 points) Force on a wire

Consider a wire which is 5 meters-long and carrying a current of 10 A in a region of space where there is a uniform magnetic field of 1 Tesla. What is the magnitude of the force on the wire if the current is at a 30° angle to the magnetic field?

Problem 4 (3 points) Dipole moment of a current loop and torque on a current loop

(a) What is the magnetic dipole moment of the "bookend-shaped" loop shown below? All sides have length L and carry a current I . (hint: break-up into parts and use the superposition principle) (b) What is the torque on this loop if it sits in a uniform magnetic field B pointing along the z-axis?

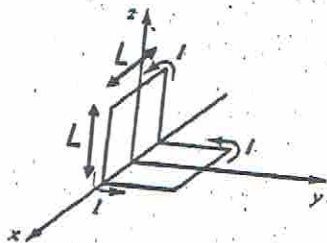

Problem 5 (1 points) Motion in a uniform magnetic field

Explain why it is *impossible* for a magnetic field to change the *speed* (magnitude of velocity) of a charged particle. (1 sentence + 1 equation)

Problem 6 (3 points) Biot-Savard Law 1

Find the magnetic field at the center of the square loop shown below. (hint: use the superposition principle)

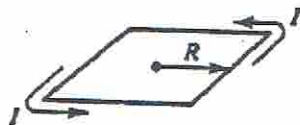

***Problem 7 (3 points) Biot-Savard Law 2**

What is the magnetic field (vector) at point P ? The straight portions of the wire are very long, and the part which is bent is an arc of a circle of radius R .

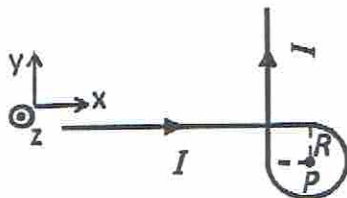

Problem 8 (3 points) Force between 2 wires

Find the force on an equilateral triangular loop (shown below) of side length S and placed a distance S away from an *infinite* straight wire (you can use the formula for \vec{B} from an infinite wire from the book). Both carry a current I . Define an x - y - z coordinate system and give your answer in vector form.

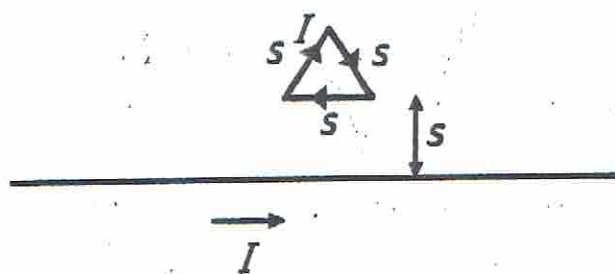

Grading: Out of 25 points, each problem's weight is indicated. The problem set must be handed-in on the due date. Assignments that are late will be penalized 20% per day that they are late. Late assignments can be slipped under my office door.

Format: For each problem you must draw a diagram detailing the situation. Zero point will be given for a good answer without the proper derivation (intermediate steps). Write clearly and detail (very briefly) the logic of the steps that you are using. If I cannot understand what you are doing, you will lose marks.

Problem 1 (4 points) Ampere's Law 1

A current I flows down a long cylindrical wire (shown below). Using Ampere's Law (a) find the magnetic field both inside ($r < R$) and outside ($r > R$) if the current is distributed uniformly inside the wire, (b) find the magnetic field both inside ($r < R$) and outside ($r > R$) if all of the current flows only on the surface of the wire.

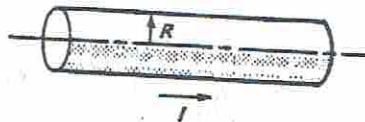

*Problem 2 (3 points) Ampere's Law 2

Two long coaxial solenoids each carry a current $I = 1A$ in opposite directions (shown below). The inner solenoid has a radius 1m and 1000 turns per meter, the outer solenoid has a radius 2m and 500 turns per meter. Find \vec{B} (a) inside the inner solenoid, (b) between the two, and (c) outside both. Use the superposition principle!



Problem 3 (2 points) Magnetic flux

$$\begin{aligned} a) \phi_B &= BA \cos \theta \\ &= 0.2(1 \times 0.5) \cos 0 \\ &= 1 \end{aligned}$$

$$\begin{aligned} b) \phi_B &= BA \cos \theta \\ &= 0.2(1 \times 0.5) \cos 50 \end{aligned}$$

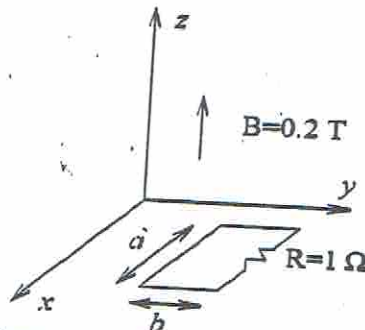

A coil of resistance $R = 1 \Omega$ and sides of length $a = 0.5m$ and $b = 1m$ lies in a plane perpendicular to a magnetic field of strength $B = 0.2T$, as shown above. (a) What is the magnetic flux through the loop? (b) What would be the flux if \vec{B} makes an angle of 50° with respect to the z -axis?

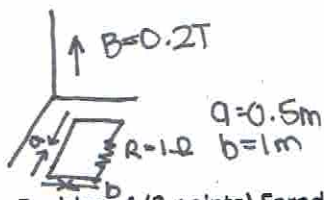

Problem 4 (3 points) Faraday's Law 1

Consider again the circuit shown in Problem 4, when the magnetic field is along the z-axis. Suppose that the magnetic field is reduced at a uniform rate until it is entirely turned off after 100 μs, as shown below. (a) What is the induced emf (ε) around the loop? (b) What is the induced current (magnitude and direction)? (c) What is the induced current after t=100 μs if B remains zero?

$\Delta t = 100 \mu s$
 $\frac{\Delta B}{\Delta t} = \frac{B_f - B_i}{\Delta t} = \frac{0 - 0.2}{100 \times 10^{-6}}$
 $\mathcal{E}_{mf} = -A \cos \theta \frac{\partial B}{\partial t} = 10.5 \times 1 \cos 0 \frac{(0 - 0.2)}{100 \times 10^{-6}}$

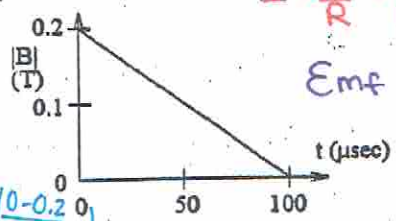

$I = \frac{\mathcal{E}}{R} = \left(\frac{0.5 \cdot 1 \cdot \frac{0.2}{100 \times 10^{-6}}}{1} \right) = 1 \text{ Amp}$

Emf after 100 μs = 0 since no rate of change

Problem 5 (3 points) Faraday's Law 2 unit: volt

In the circuit shown below, the bar is moving at a constant velocity \vec{v} . There is a uniform magnetic field \vec{B} pointing out of the page everywhere. The circuit has zero resistance except for the resistor R . (a) What is the induced ε in the circuit? (b) How much power is dissipated in the resistor R ? (c) What is the force (magnitude and direction) exerted on the bar by the magnetic field?

a) $\mathcal{E} = -\frac{\partial \phi_B}{\partial t} = -B \cos \theta \frac{\partial A}{\partial t} = 0$
 $= -B \frac{\partial A}{\partial t} = -BLV = \mathcal{E}$ (motional voltage/emf)
 $A = L \cdot b \Rightarrow \frac{\partial A}{\partial t} = \frac{\partial (L \cdot b)}{\partial t} = L \frac{\partial b}{\partial t} = Lv$

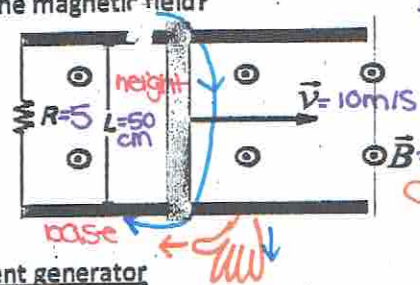

b) $I = \frac{\mathcal{E}}{R} = \frac{10V}{5\Omega} = 2A$

c) direction clockwise
 current ↑ magnetic field out of the page
 Area ↑ flux ↑ opposite out of the page (thumb)
 direction of rotation counter clock.
 d) $F_B = ILB \sin 90 = (2)(.5)(2) = 1 = 2N \leftarrow$

Problem 6 (3 points) Alternating current generator

A rectangular loop of N turns of length a and width b is rotated with a frequency f in a uniform magnetic field \vec{B} directed into the page (see below). (a) Calculate the induced emf that appears in the loop (generator) as a function of time. (b) Design a loop (give dimensions) that will produce a peak value of 220V when rotated at 60Hz in a 1T field.

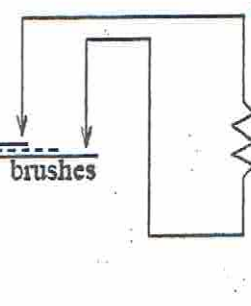
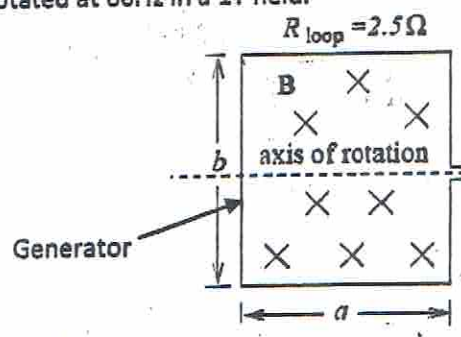

e) mechanical power on rod
 $F_{applied} = F_B$
 f) Power = $FV = 2(10) = 20 \text{ watt}$

Problem 7 (2 points) Eddy currents

A metal pendulum (shown below) is moving into a magnetic field. (a) What is the orientation of the induced eddy currents? (b) What is the direction of the force on the pendulum that results from the eddy currents?

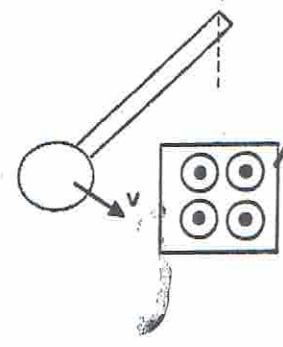

B is out of the page in this region and zero everywhere else

comment: conservative of energy

Phys 205, section 03 - Winter 2012

Problem Set #6

Due date: April 4th

Grading: Out of 23 points, each problem's weight is indicated. This assignment can be slipped under my office door or dropped in my mailbox in the Physics dept. Assignments that are late will be penalized 20% per day that they are late.

Format: For each problem you must draw a diagram detailing the situation. Zero point will be given for a good answer without the proper derivation (intermediate steps). Write clearly and detail (very briefly) the logic of the steps that you are using. If I cannot understand what you are doing, you will lose marks.

Problem 1 (2 points) RL circuit

For the circuit shown below, let $L = 5 \text{ H}$, $R = 9 \Omega$, $\mathcal{E} = 12 \text{ V}$. (a) What is the self-induced EMF across the inductor, 0.1 s after the switch is closed? (b) What is the current 0.2 s after the switch is closed?

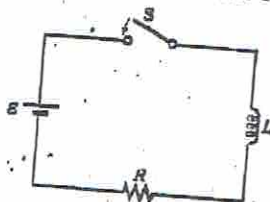

Problem 2 (3 points) LC circuit

Consider the LC circuit shown below. If the capacitor has an initial charge Q (before the switch is closed), and the switch is closed at $t=0$. At $t = 5s$, what is the energy stored in the (a) capacitor, (b) inductor, (c) the whole circuit? (hint: give your answer in terms of L, C , and Q , and harmonic functions. Try it first with numbers if it helps you.)

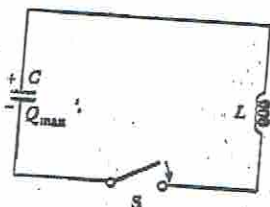

Problem 3 (2 points) Voltage across L and C

- (a) An inductor of 1 H carries a current $I = 5\cos(100t) \text{ A}$. What is the voltage across it?
- (b) A capacitor $C = 10 \mu\text{F}$ carries the same current, what is the voltage across it?

Problem 4 (4 points) Impedance of RLC circuits

For the circuits branches below (a) and (b), give their total impedance Z and the phase angle ϕ between the current and voltage across them.

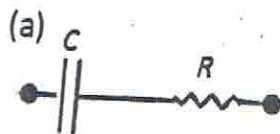

Problem 5 (4 points) Power in RLC circuits

For the circuit below, what is the power dissipated in (a) the whole circuit? (b) between points *a* and *b*?

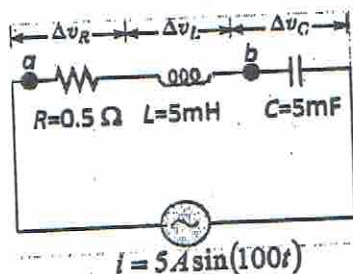

Problem 6 (2 points) Transformer

In a transformer, the voltage across the primary coil is 120 V rms, and the voltage across the secondary coil is 10 kV rms (i.e. 10 000V). The impedance *Z* of the primary coil is 50 Ω, and the transformer is ideal (100% power transmission). (a) What is the number of turn ratio N_1/N_2 ? (b) What is the impedance of the secondary coil?

Problem 7 (2 points) Electromagnetic wave

The electric field in an electromagnetic wave is given by the following (using the standard units) $E_y = 20\cos(10^7x - \omega t)$ where *x* is the position along the *x*-axis and the electric field points along the *y*-direction. Find (a) the amplitude, (b) the wavelength and (c) the frequency *f* of the *B* field oscillations.

Problem 8 (2 points) Electromagnetic wave 2

A light bulb radiates an electromagnetic wave in all directions with a total power of 100 Watts. If you stand 5 meters away from the bulb, what is the amplitude of the magnetic field (B_{max}) of the radiation hitting you?

Problem 9 (2 points) Energy carried by an E&M wave

The intensity of sunlight hitting the Earth is about 1300 W/m². (a) Find the amplitude of the electric and magnetic fields? (b) How much pressure (per square meter) does it exert?

Thanks for your hard work this semester, and good luck on your finals!

Alex