

The concept of nuclear power reactor

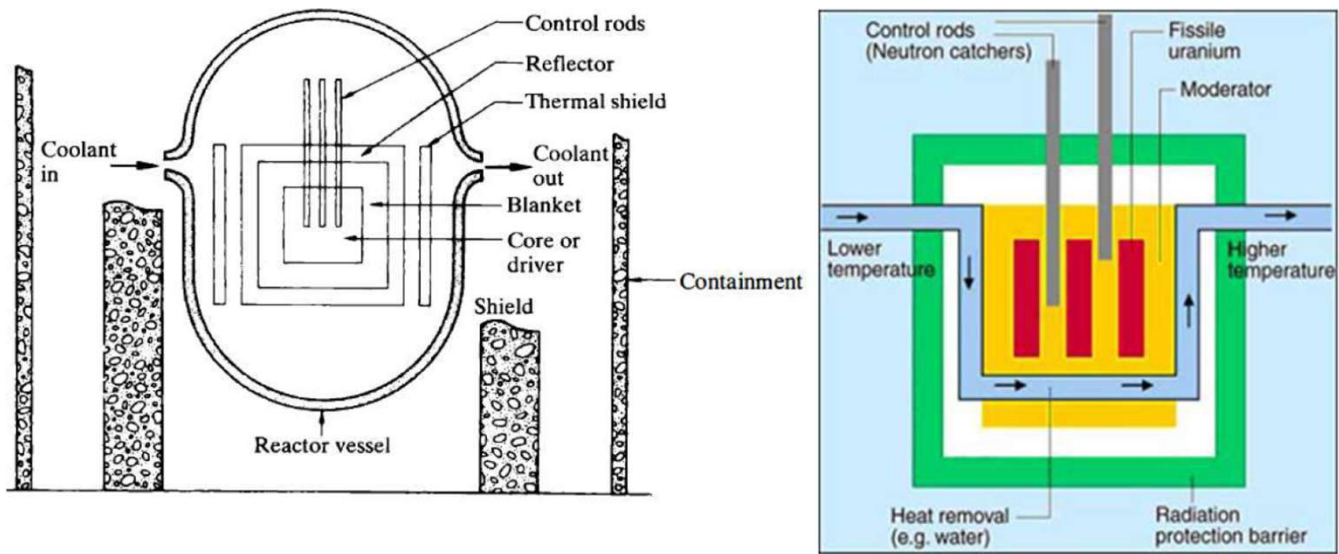

Pressurized Water Reactors (PWR)

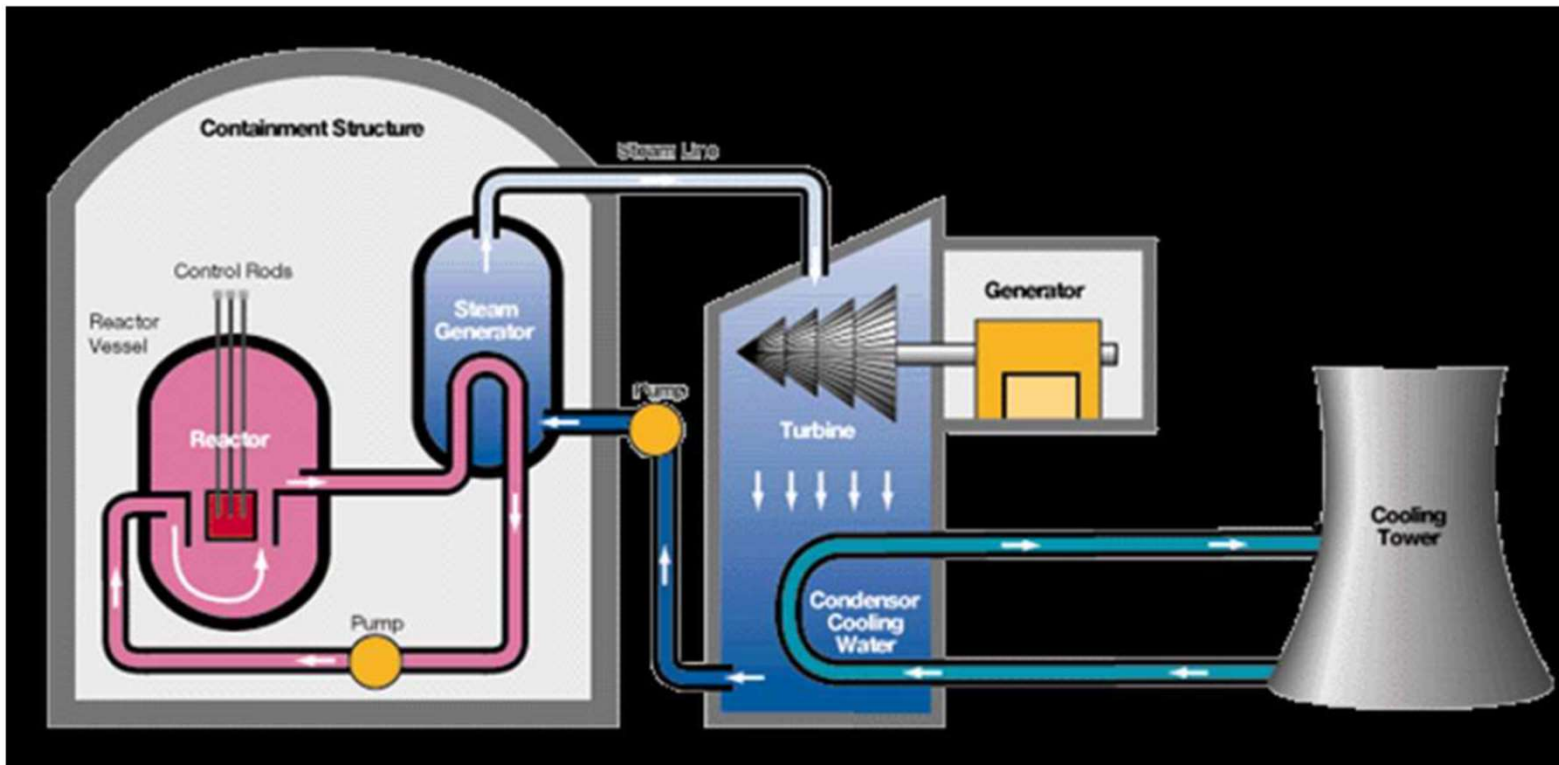

Pressurized Water Reactor Primary Side Arrangements

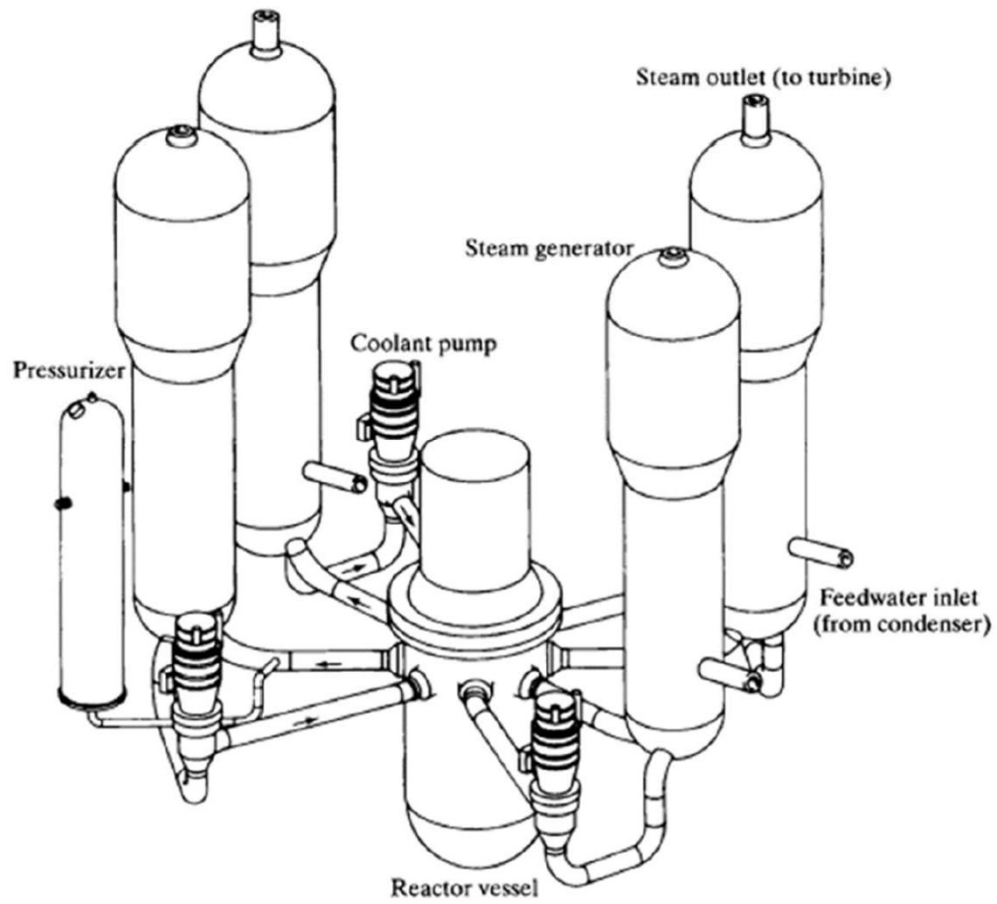

PWR Core and Pressure vessel

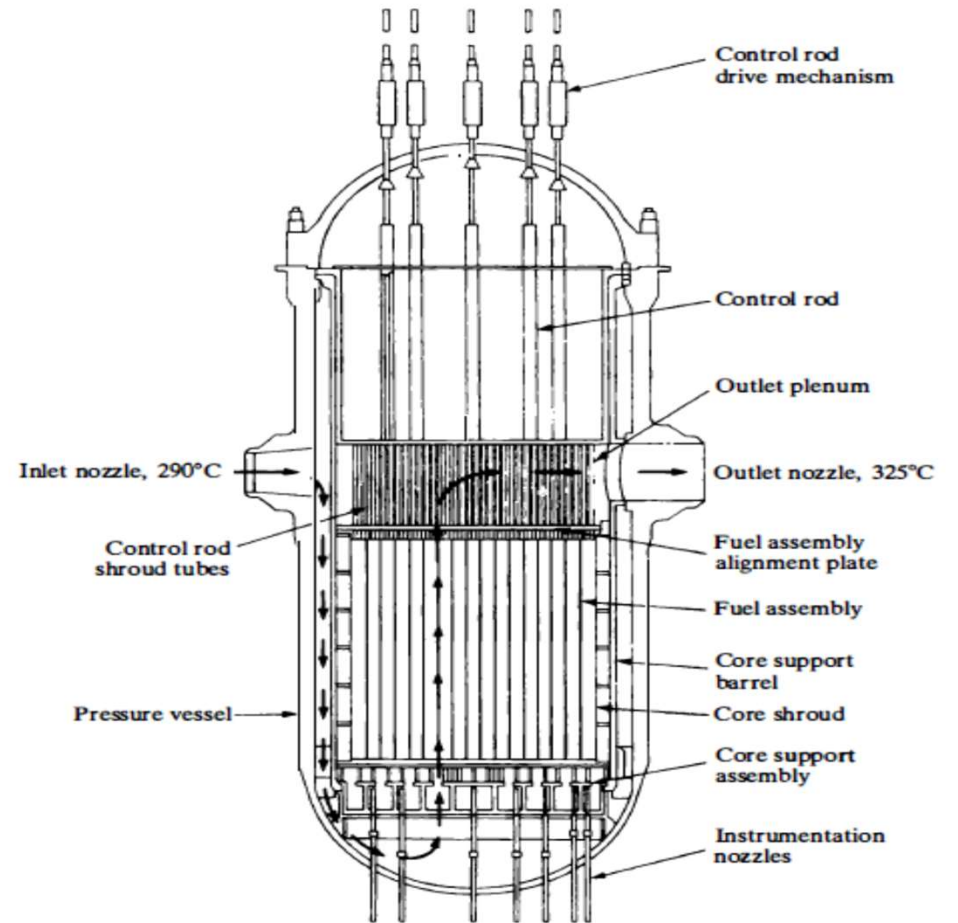
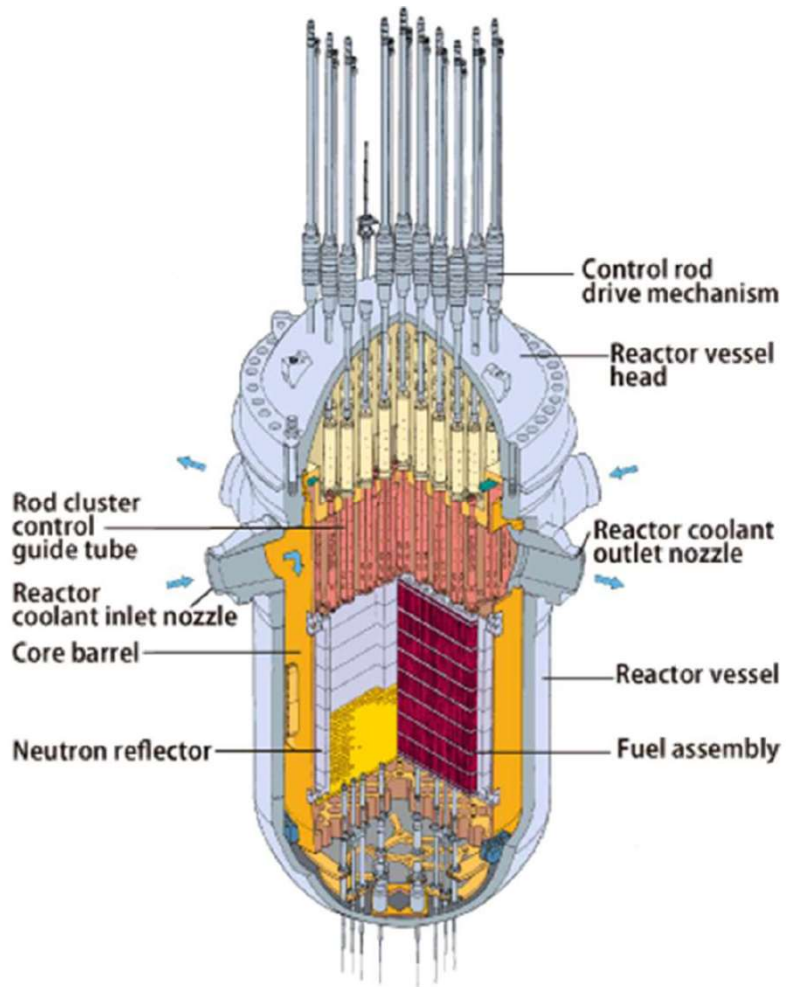

Fuel Assembly

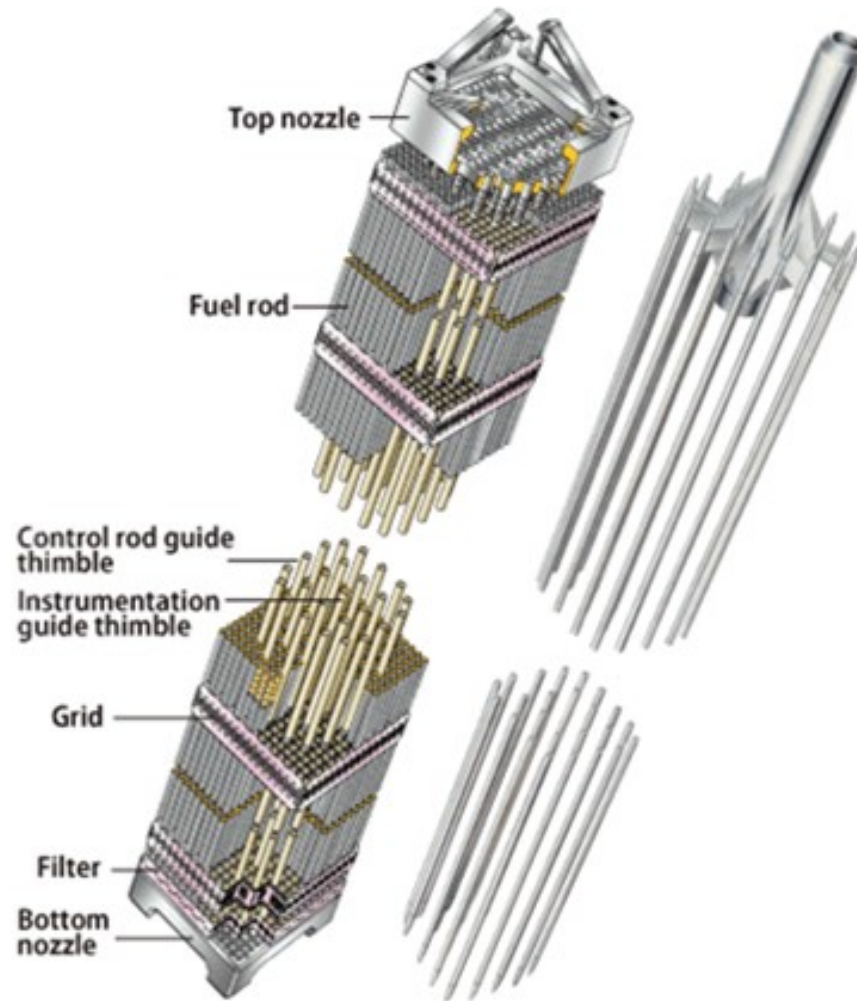

Steam Generator (Boiler)

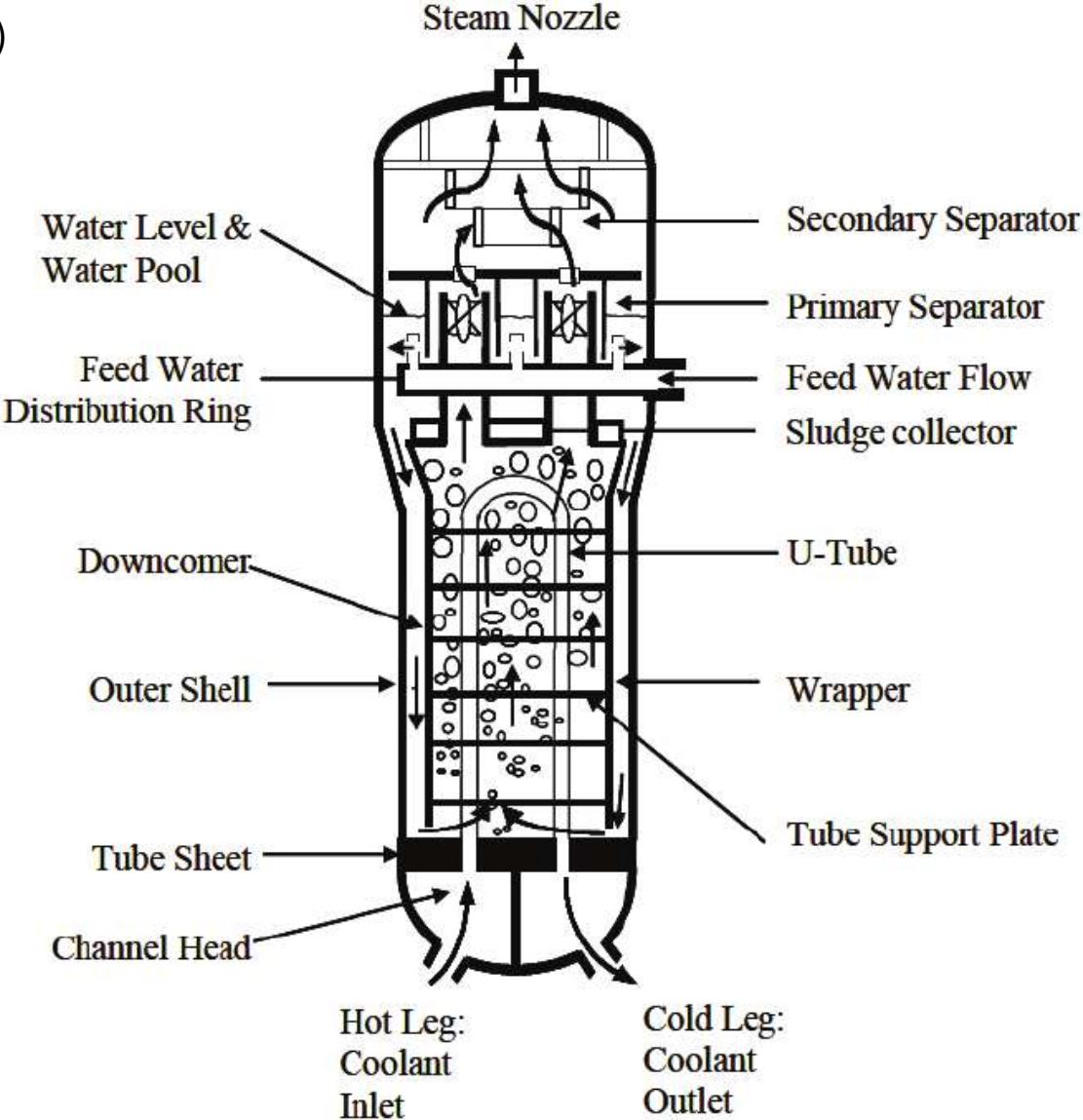

Steam Generator

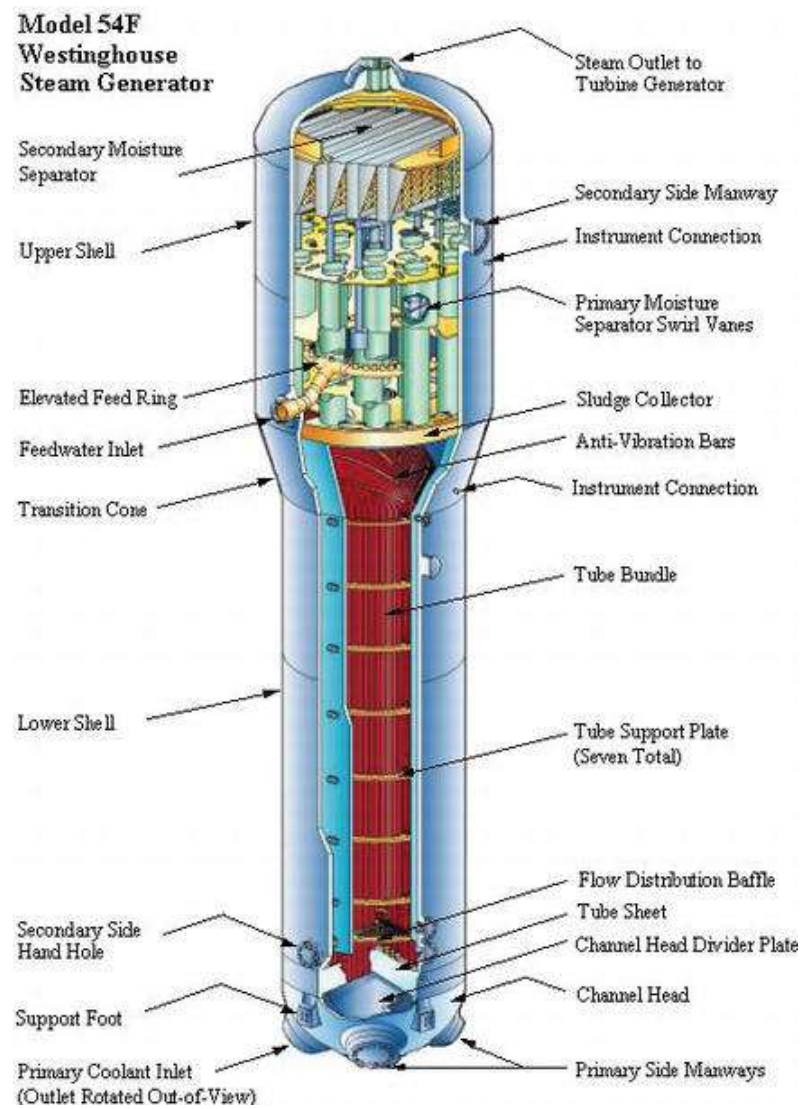

Pressurizer

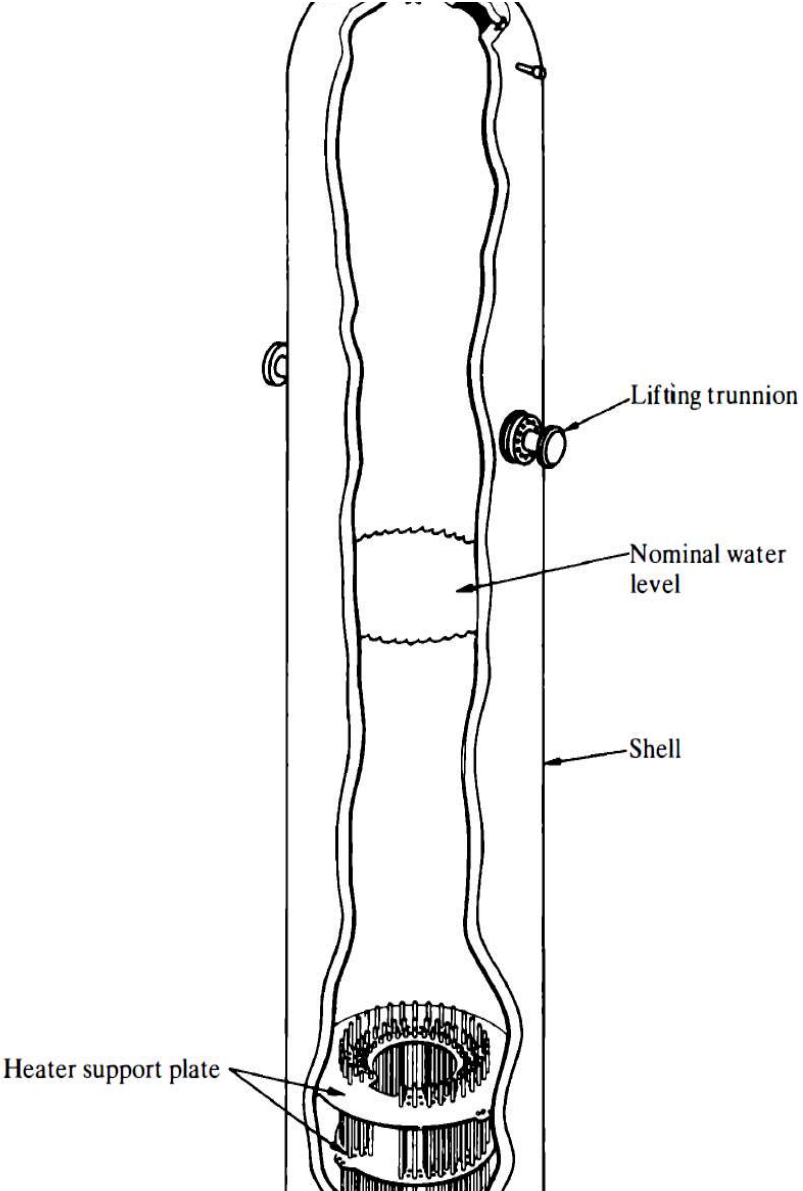

Boiling Water Reactor (BWR)

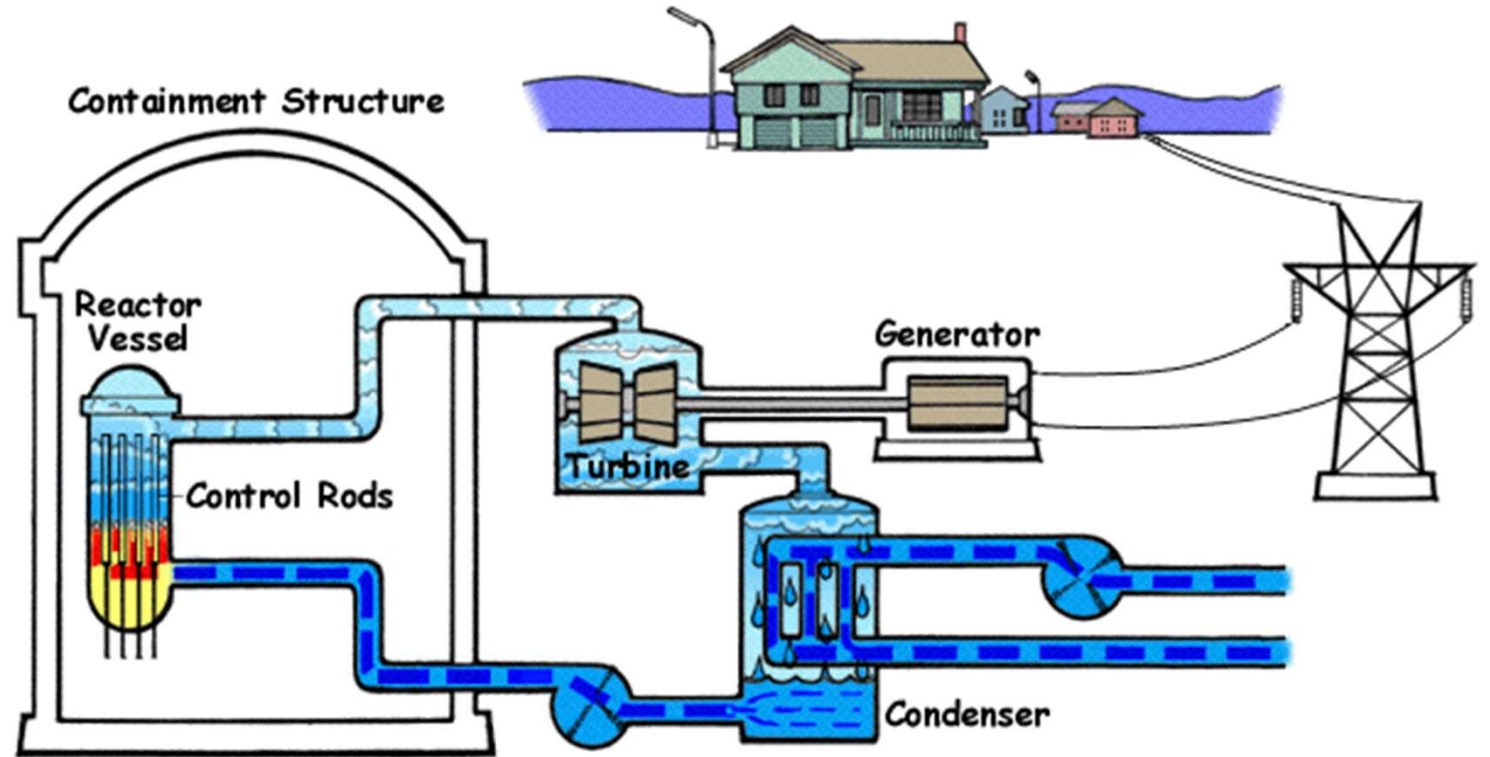

Boiling Water Reactors

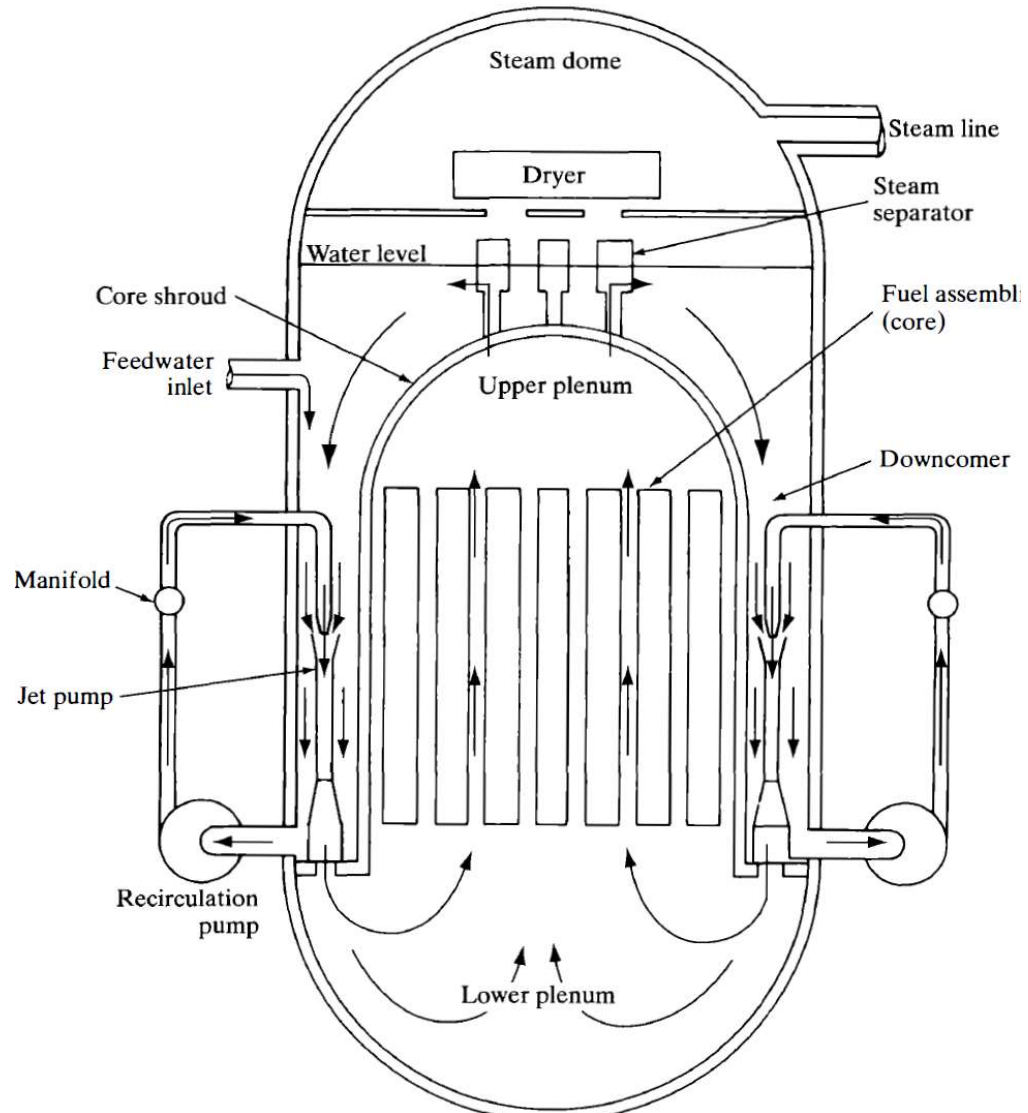

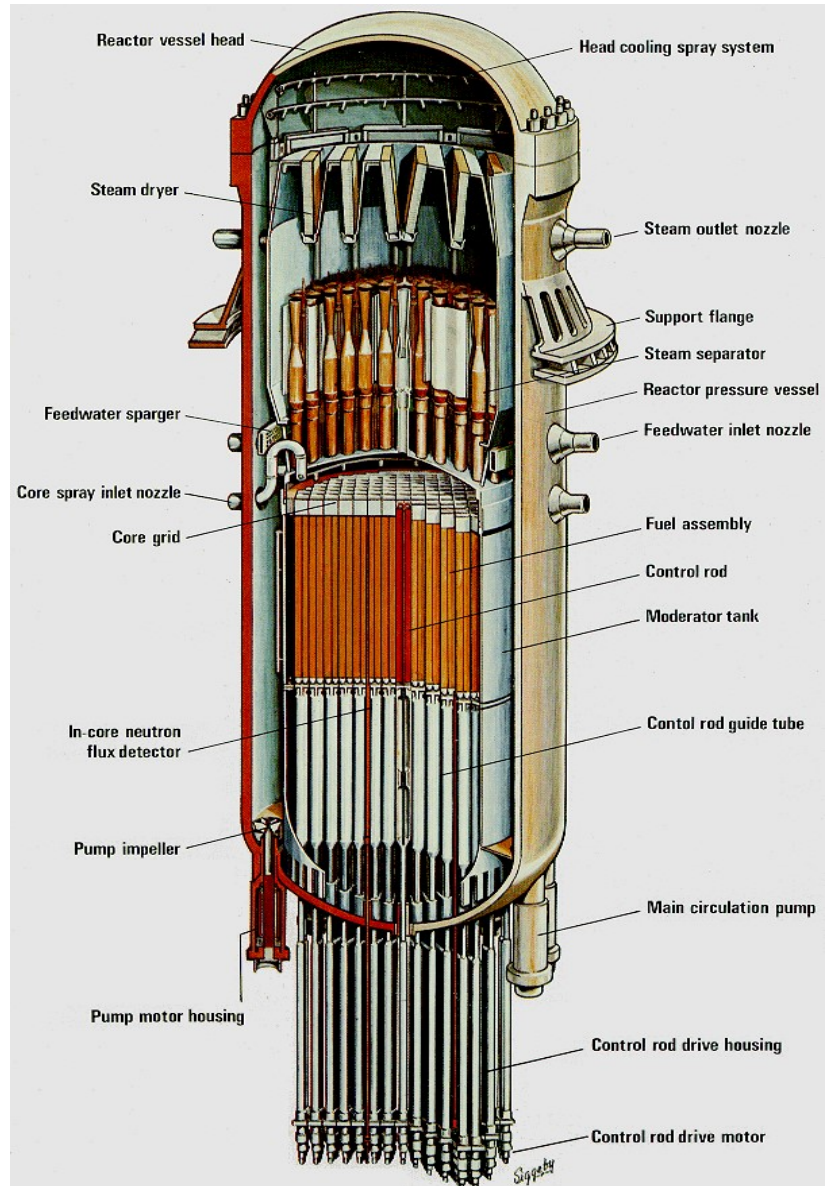

MARK I BWR

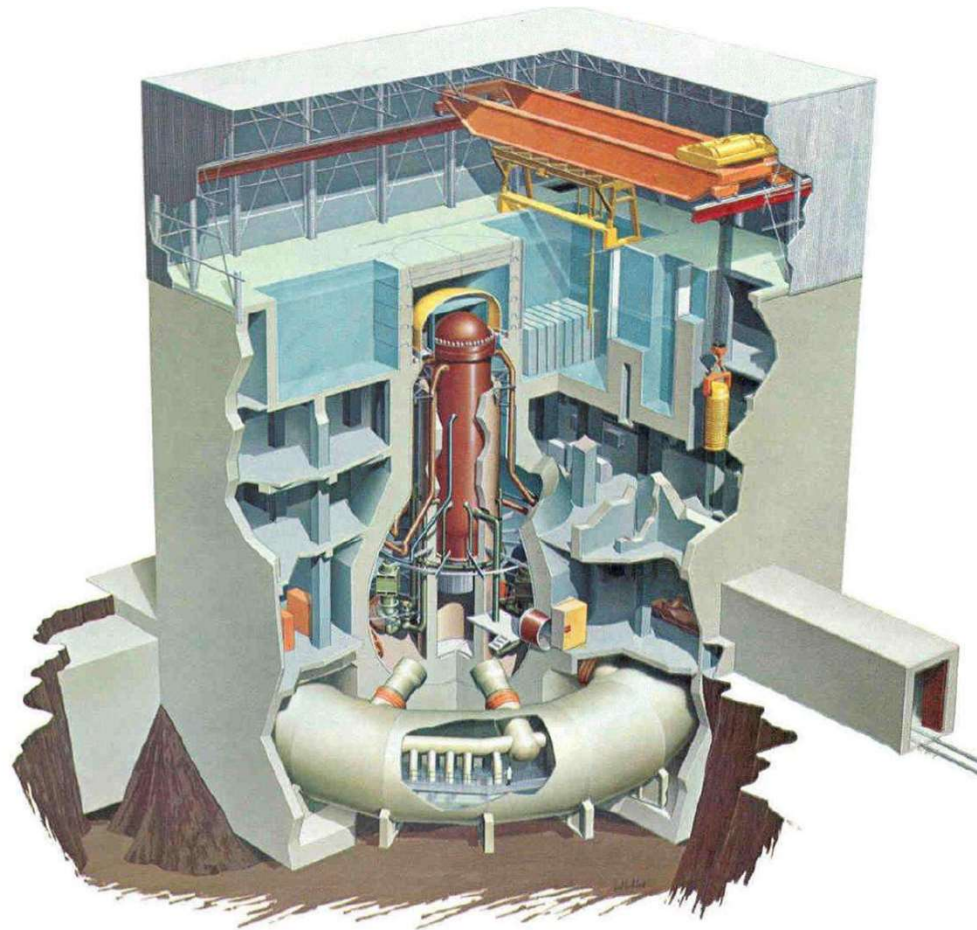

The Philosophy of Nuclear Reactor Design and Operation

Defense in Depth

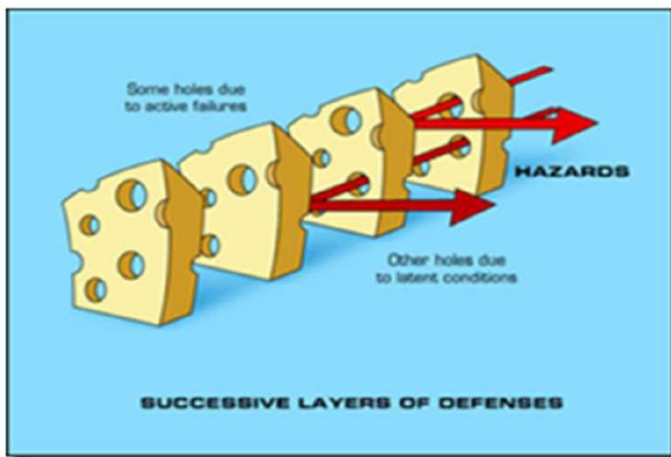

Safe Operating Envelope



Defense In Depth

- The practice of having multiple, redundant, and independent layers of safety systems to act as barriers protecting workers, the public and the environment from large releases of fission products.
- **3 C Principle:**
 - Control
 - Cool
 - Contain

CANDU PRESSURIZED HEAVY WATER REACTOR

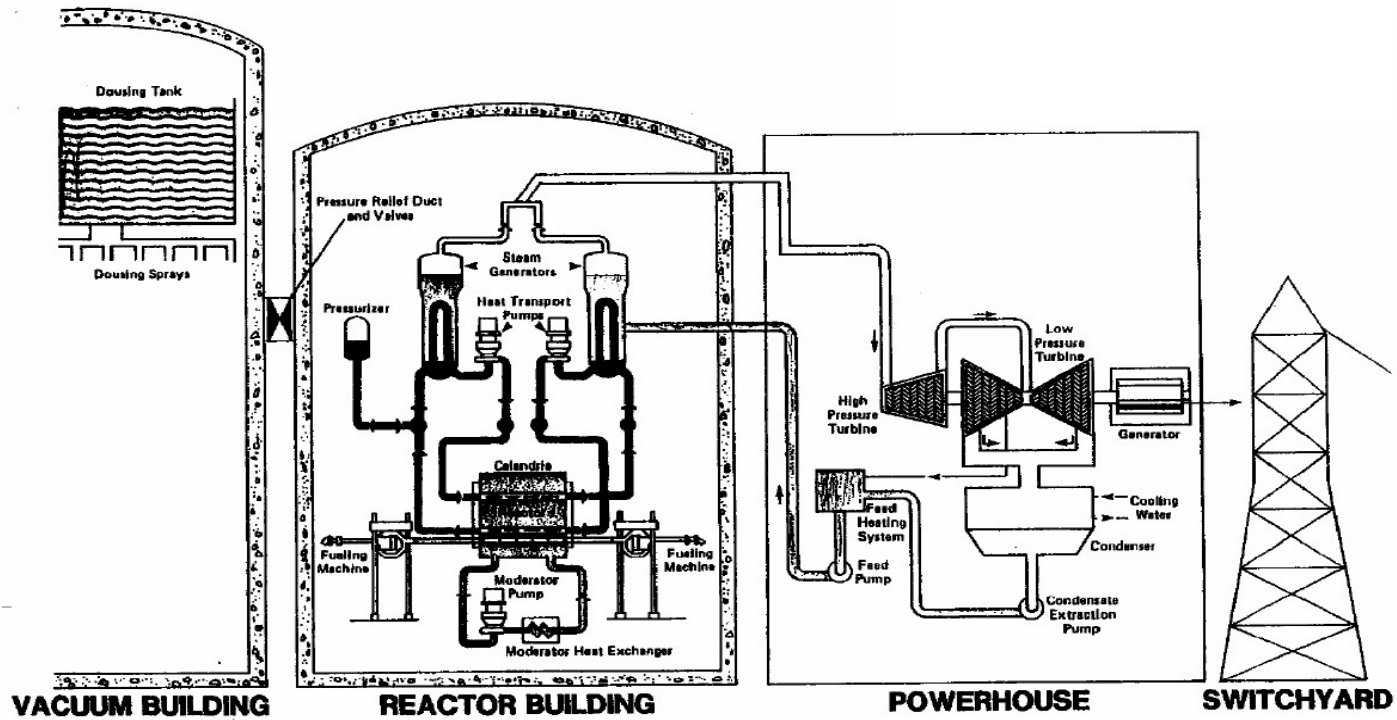

CANDU Design Overview

- CANDU (CANada Deuterium Uranium)
- Neutron economy
- Natural uranium Fuel
- Separated heavy water (D_2O) coolant and moderator
- Distributed core (fuel channels)
- On-power fuelling

Main CANDU Reactor Systems

- Reactor Assembly
- Fuel and Fuel Channel
- Heat Transport System
- Pressure and Inventory Control System
- Moderator System
- Special Safety Systems

CANDU Reactor

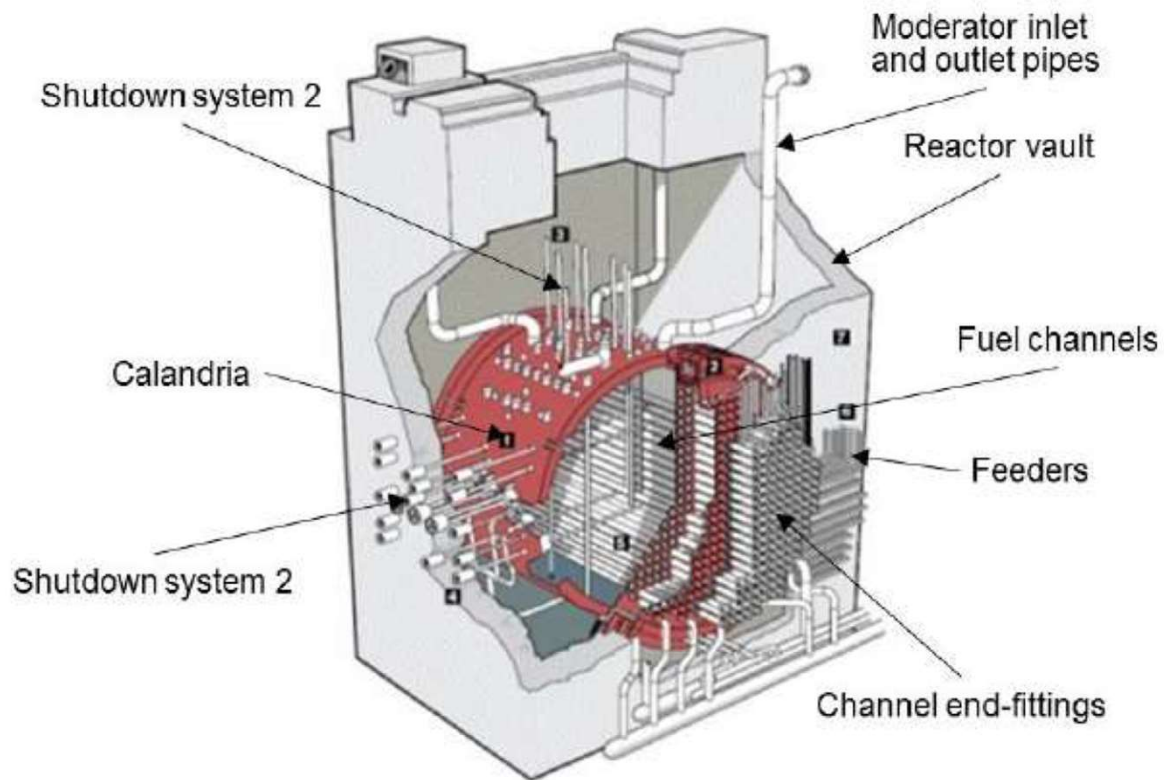

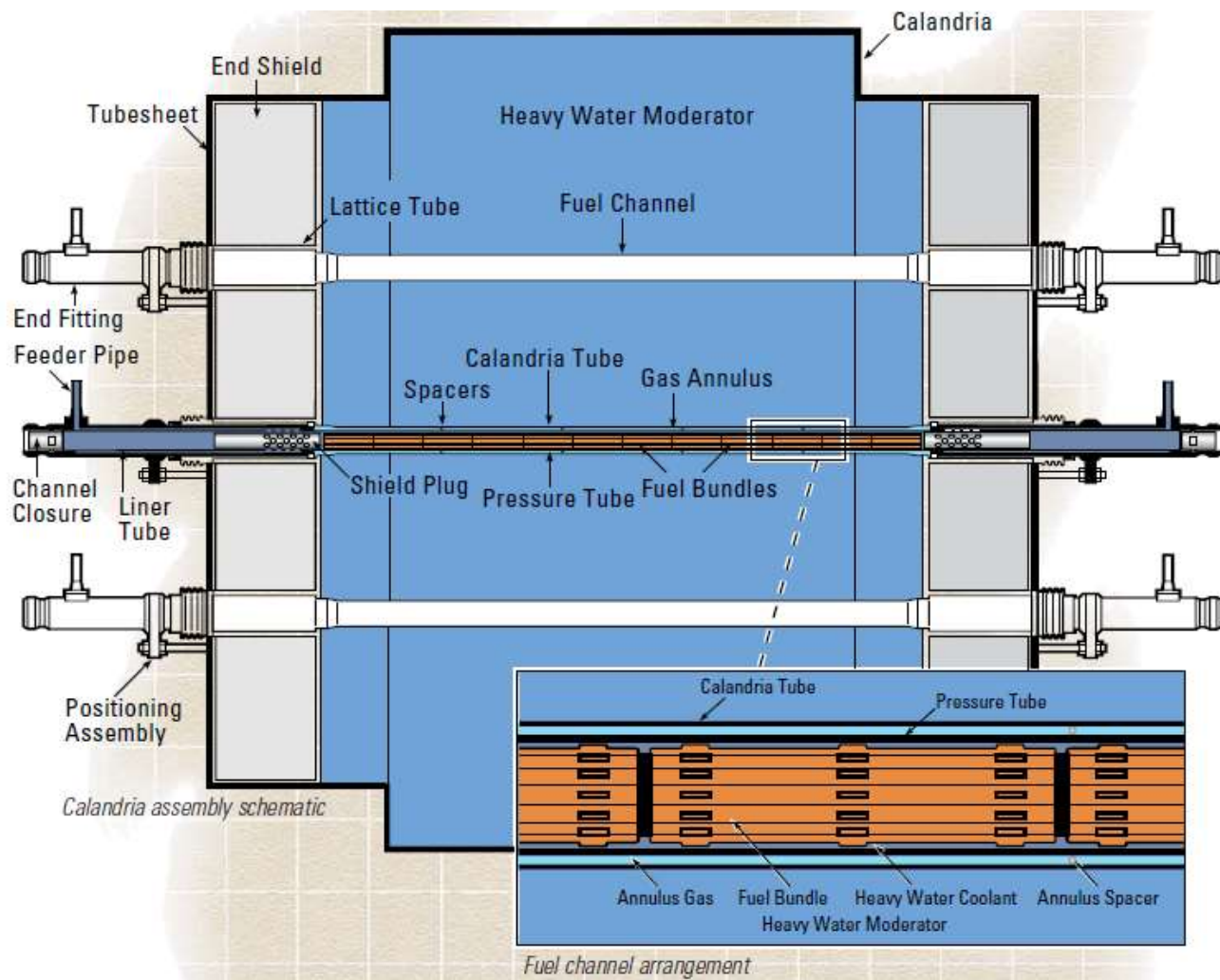

Nuclear Power Plant Safety Systems - YouTube

Understanding Nuclear Power Plants: Total Station Blackout - YouTube

Calandria

- Low pressure tank
- Supports calandria tubes and pressure tubes
- Contains heavy water moderator
- Contains reactivity devices and shut down systems
- Embedded in light water shield tank
- Provides passive emergency heat sink in the event of a loss of coolant accident + loss of emergency cooling



AECL
EACL

CANDU

WOLSONG 2

MANUFACTURED BY

FABRIQUE PAR



GEC ALSTHOM

ELECTROMECHANIQUE

TRACY (QUÉBEC)

CANADA

SUPPLIED BY NPM

THE INFORMATION PROVIDED HEREIN IS FOR INFORMATION ONLY AND IS NOT TO BE USED FOR ANY OTHER PURPOSE. IT IS THE RESPONSIBILITY OF THE USER TO VERIFY THE ACCURACY OF THE INFORMATION PROVIDED HEREIN. THE INFORMATION IS PROVIDED AS IS AND WITHOUT WARRANTY OF ANY KIND, EXPRESS OR IMPLIED, INCLUDING BUT NOT LIMITED TO THE WARRANTIES OF MERCHANTABILITY, FITNESS FOR A PARTICULAR PURPOSE AND NONINFRINGEMENT. IN NO EVENT SHALL THE INFORMATION PROVIDER BE LIABLE FOR ANY DAMAGES, INCLUDING CONSEQUENTIAL DAMAGES, ARISING OUT OF THE USE OF THE INFORMATION PROVIDED HEREIN.

TNT

D

Fuel Channel Core Design

- Sub-divided reactor coolant system, no large pressure vessel
- Cool moderator separated from coolant
- Zr-2.5%Nb pressure tubes constitute CANDU pressure vessel
- Individual pressure tubes are replaceable
- Interstitial reactivity devices (between fuel channels)
- Distributed core allows cooling to be maintained with failure of small diameter reactor coolant system (a pressure tube or a feeder pipe)

Pressure Tube Arrangement

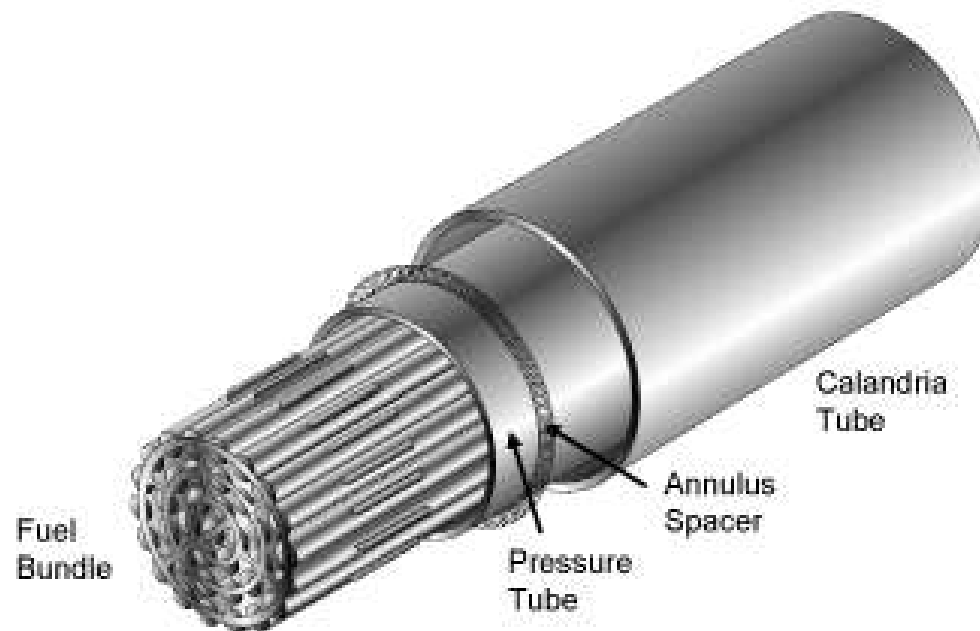

CANDU 6 Fuel Channel

CANDU 6 Fuel Channel

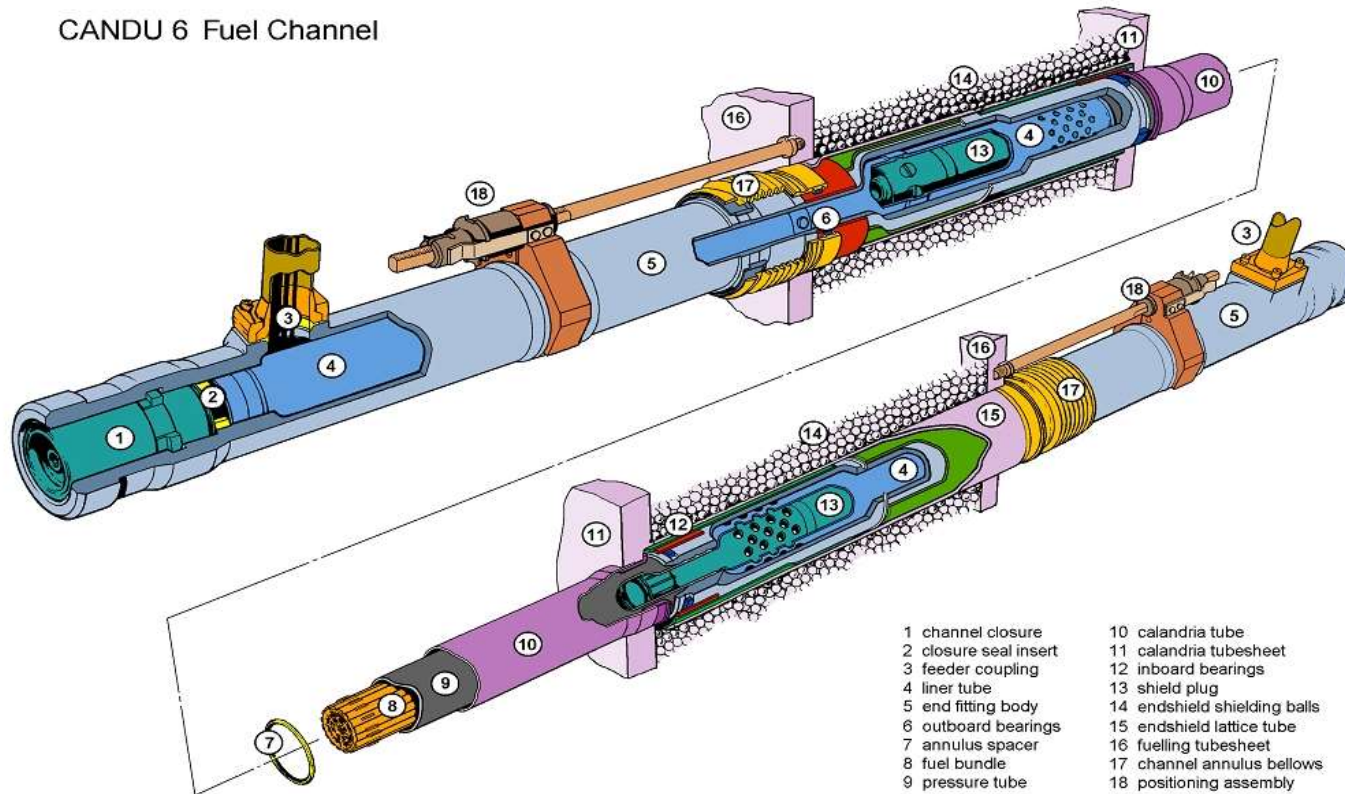

- | | |
|-----------------------|------------------------------|
| 1 channel closure | 10 calandria tube |
| 2 closure seal insert | 11 calandria tubesheet |
| 3 feeder coupling | 12 inboard bearings |
| 4 liner tube | 13 shield plug |
| 5 end fitting body | 14 endshield shielding balls |
| 6 outboard bearings | 15 endshield lattice tube |
| 7 annulus spacer | 16 fuelling tubesheet |
| 8 fuel bundle | 17 channel annulus bellows |
| 9 pressure tube | 18 positioning assembly |

SIMPLIFIED SECTION OF END FITTING

SOME SIZES EXAGGERATED FOR CLARITY

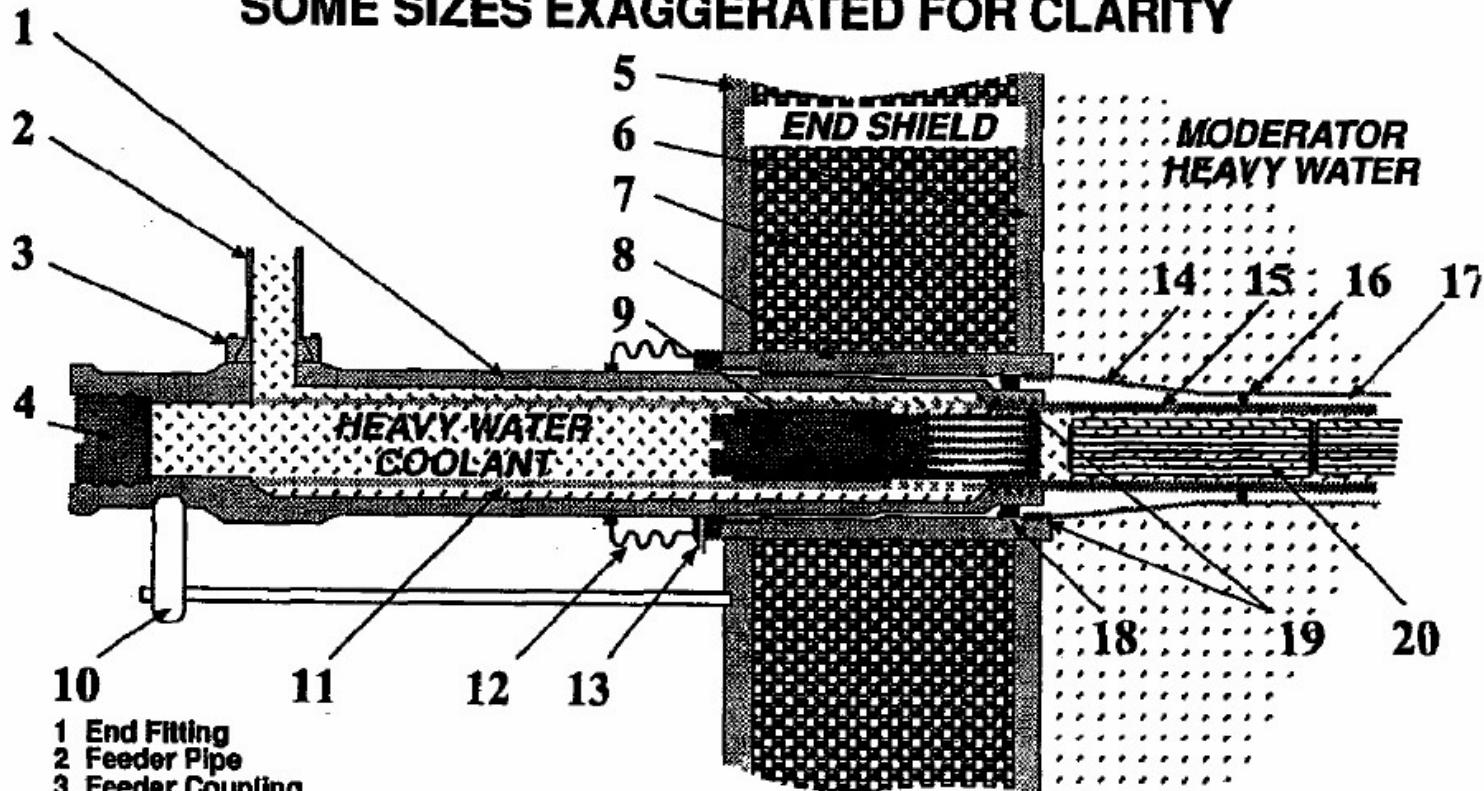

- 1 End Fitting
- 2 Feeder Pipe
- 3 Feeder Coupling
- 4 Channel Closure Plug
- 5 End Shield
 - Fuelling Machine Side Tube Sheet
- 6 End Shield
 - Calandria Side Tube Sheet
- 7 End Shield - Steel Balls
- 8 End Shield - Lattice Tube
- 9 Shield Plug

- 10 Channel Locking/Unlocking Mechanism
- 11 Liner Tube
- 12 Annulus Bellows
- 13 Annulus Gas Connection

- 14 Calandria Tube
- 15 Pressure Tube
- 16 Garter Spring Spacer
- 17 Annulus
- 18 Journal Bearing
- 19 Rolled Joints
- 20 Fuel Bundle

CANDU Fuel Bundle

- Natural uranium (0.7% ^{235}U)
- High density uranium oxide (UO_2) fuel pellets in Zircaloy-4 cladding
- Collapsible cladding under normal operating conditions.
- Short (0.5 m) fuel elements arranged in cylindrical fuel bundle

CANDU Fuel Bundle

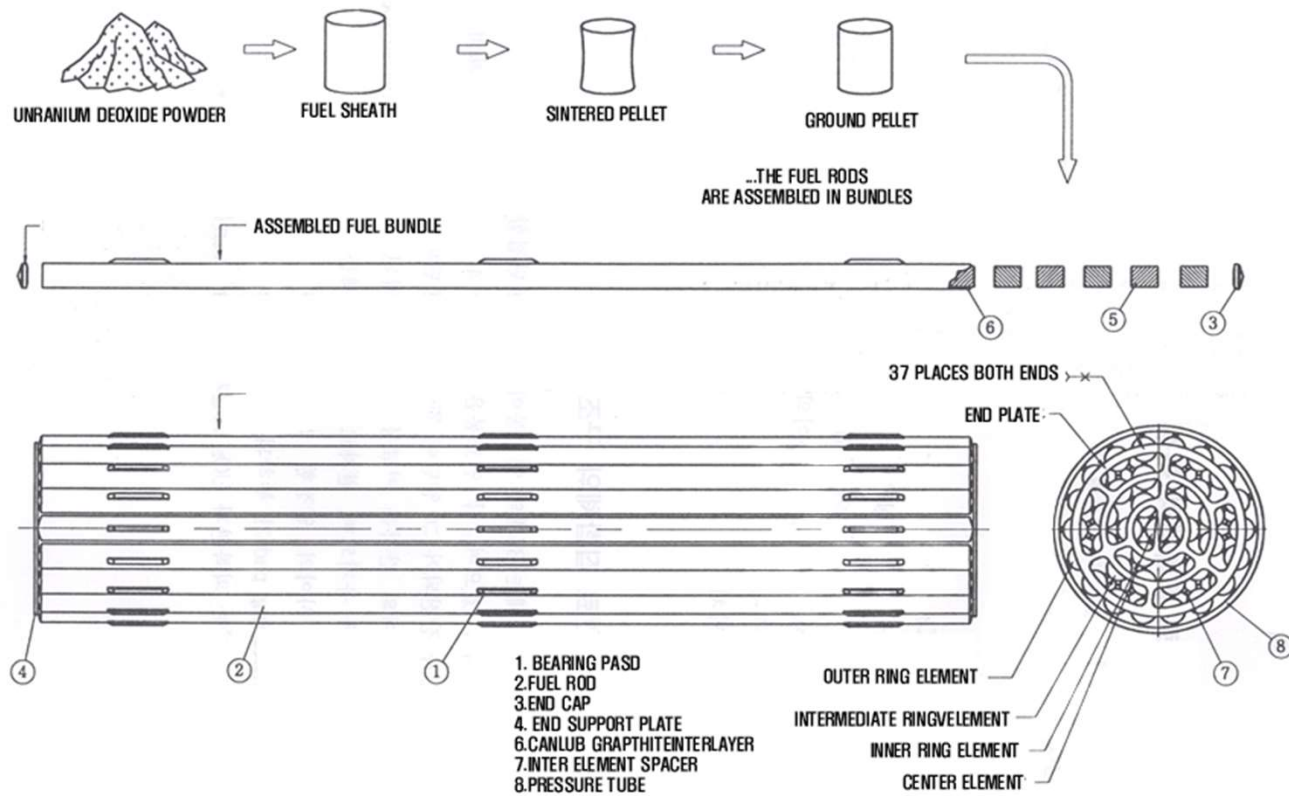

Bruce 37 Element Fuel Bundle

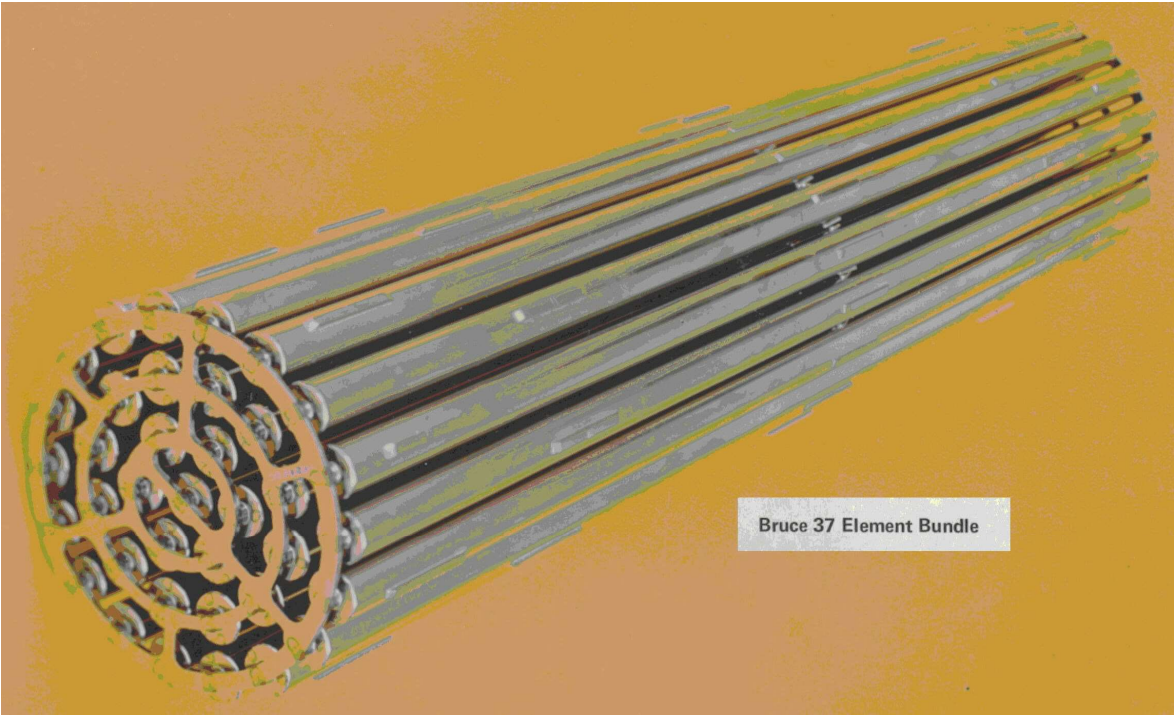

Heat Transport System

- Two independent circuits arranged as Figure of 8 with pumps and steam generators.
- System components sized to minimize D₂O inventory
- All core-external circuit components located above core to facilitate natural circulation in the event of loss of pumped flow.
- Entire reactor coolant system pressure boundary inside containment

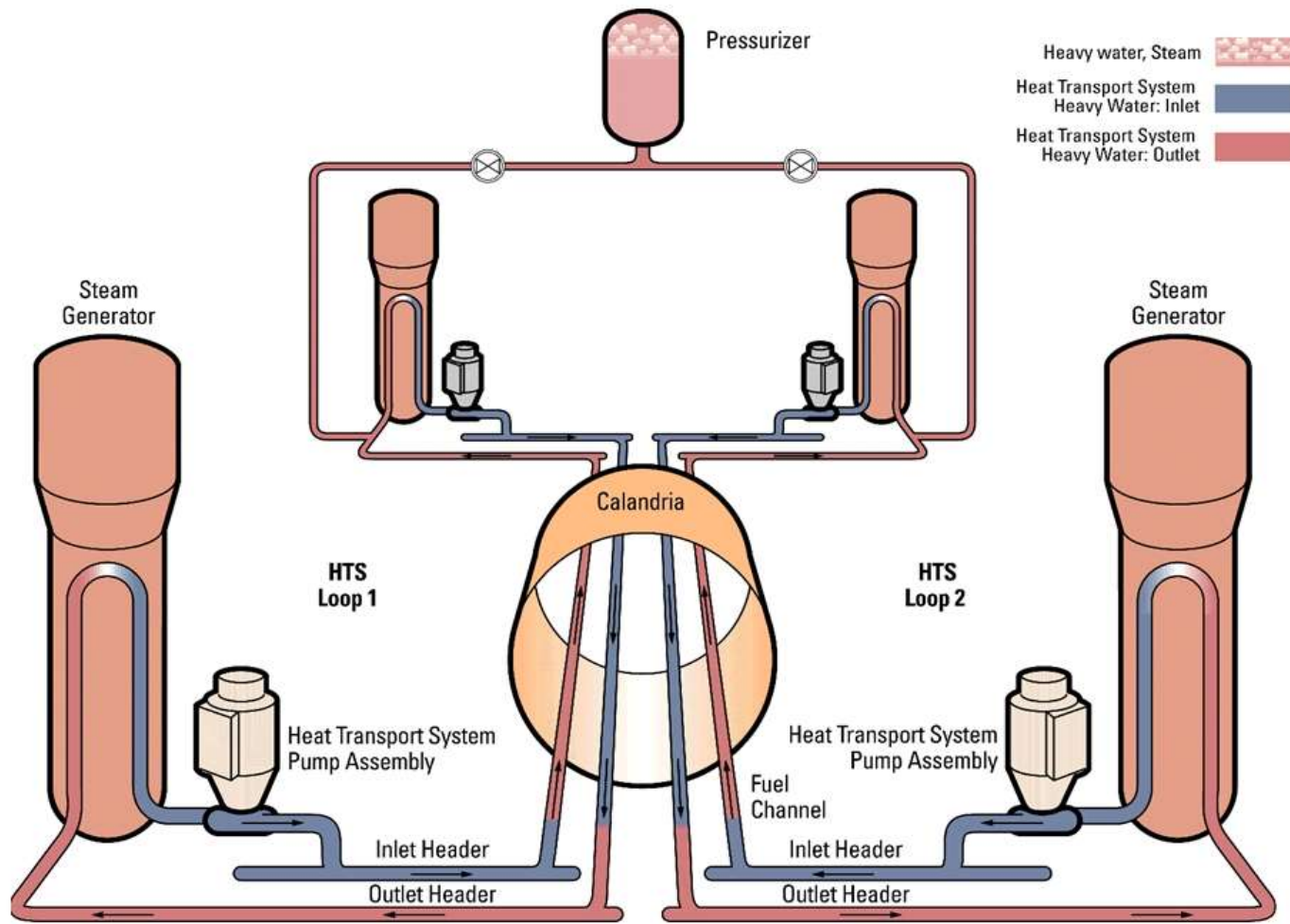

CANDU 6 Heat Transport System Parameters

- Outlet Header Pressure 10 MPa
- Outlet header temperature 310° C
- Outlet header steam quality (max. 4%)
- Inlet header temperature 266° C

Secondary Side Conditions

- Steam Pressure 4.7 MPa
- Steam quality 99.75%
- Feed water temperature 175° C

Heat Transport Pressure and Inventory Control

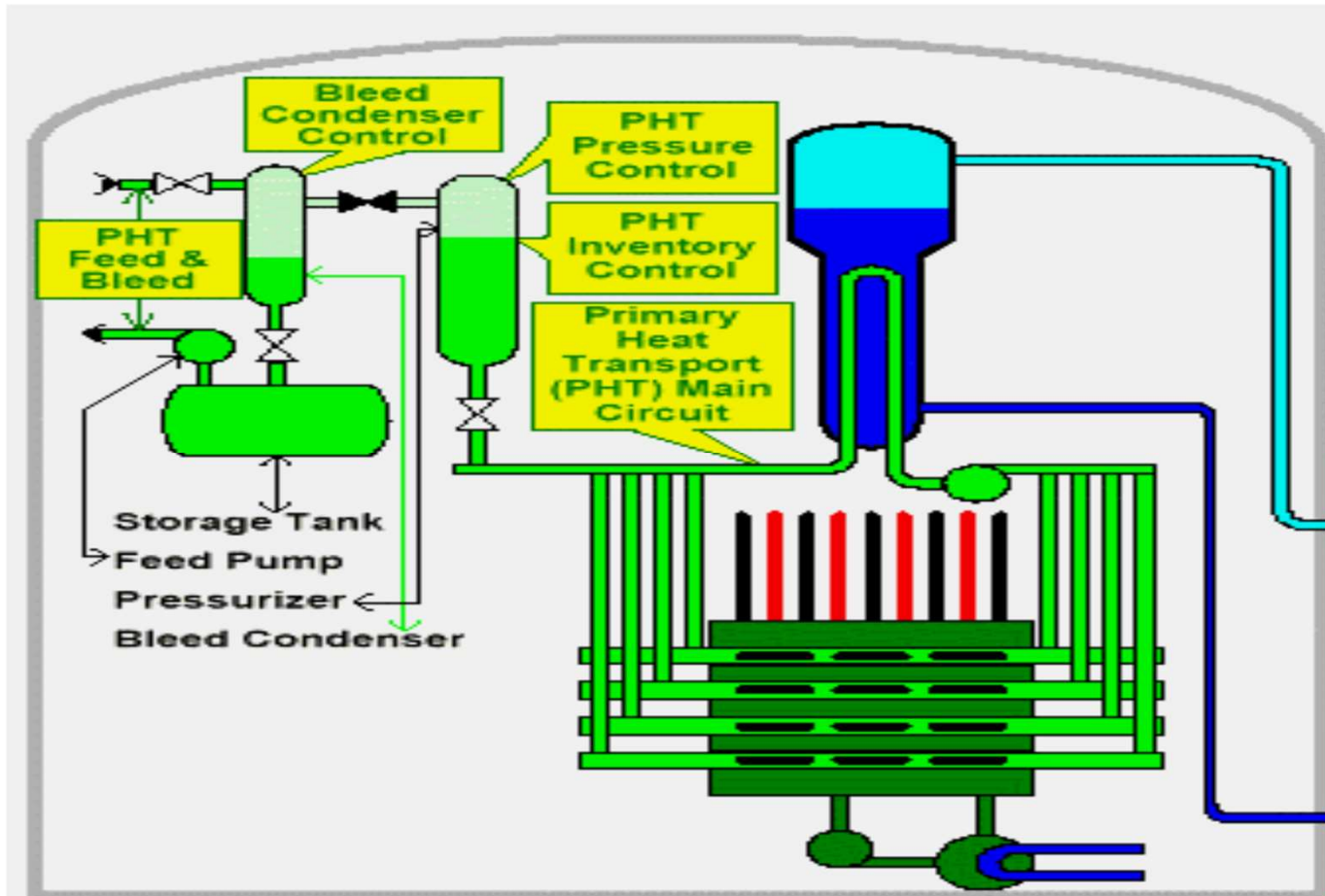

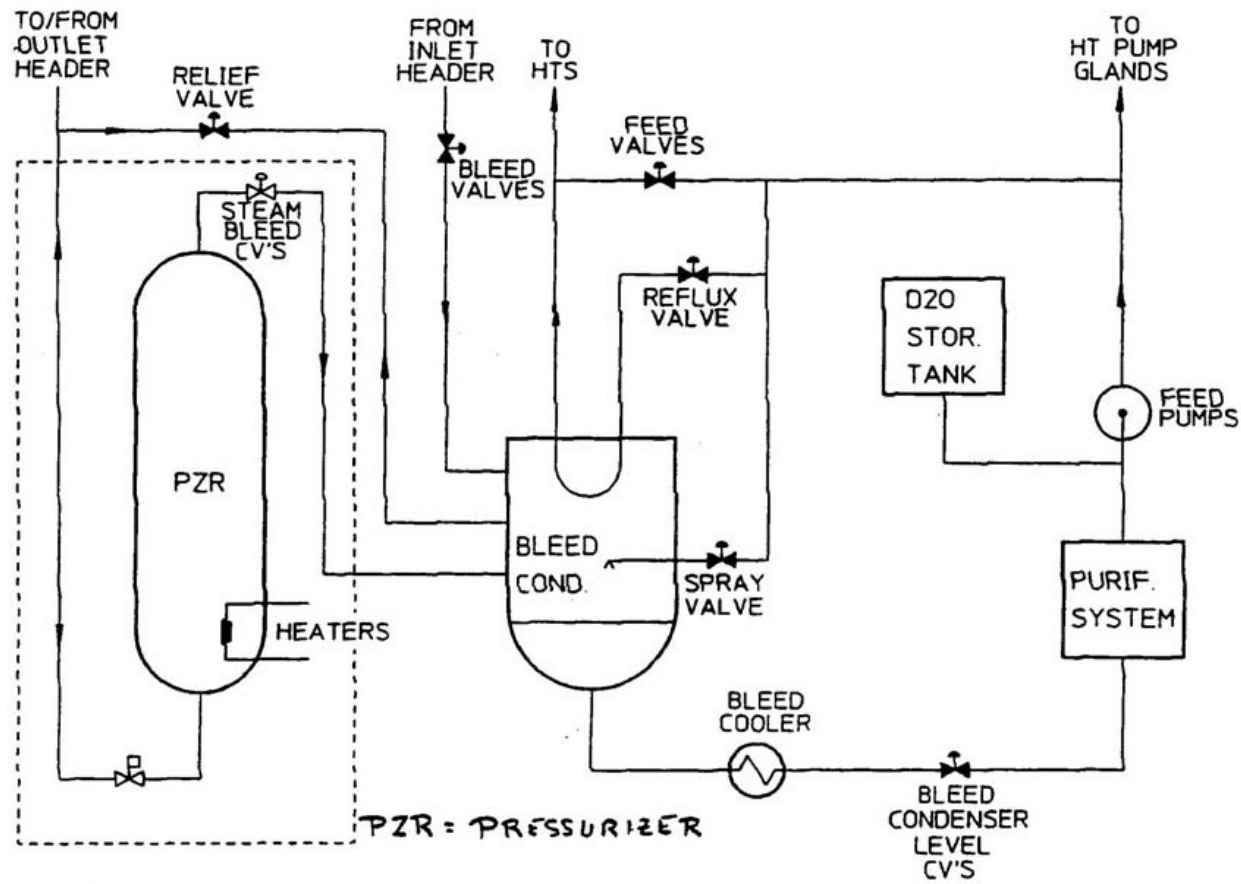

Heat Transport Pressure and Inventory Control

- Holds the PHT system pressure at the set point.
- Supply continuous coolant flow to the purification system.
- Accommodate volume changes (swell and shrink) of hot coolant during power maneuvers.
- Provide a pressure relief path in case of system over-pressurization

Moderator systems

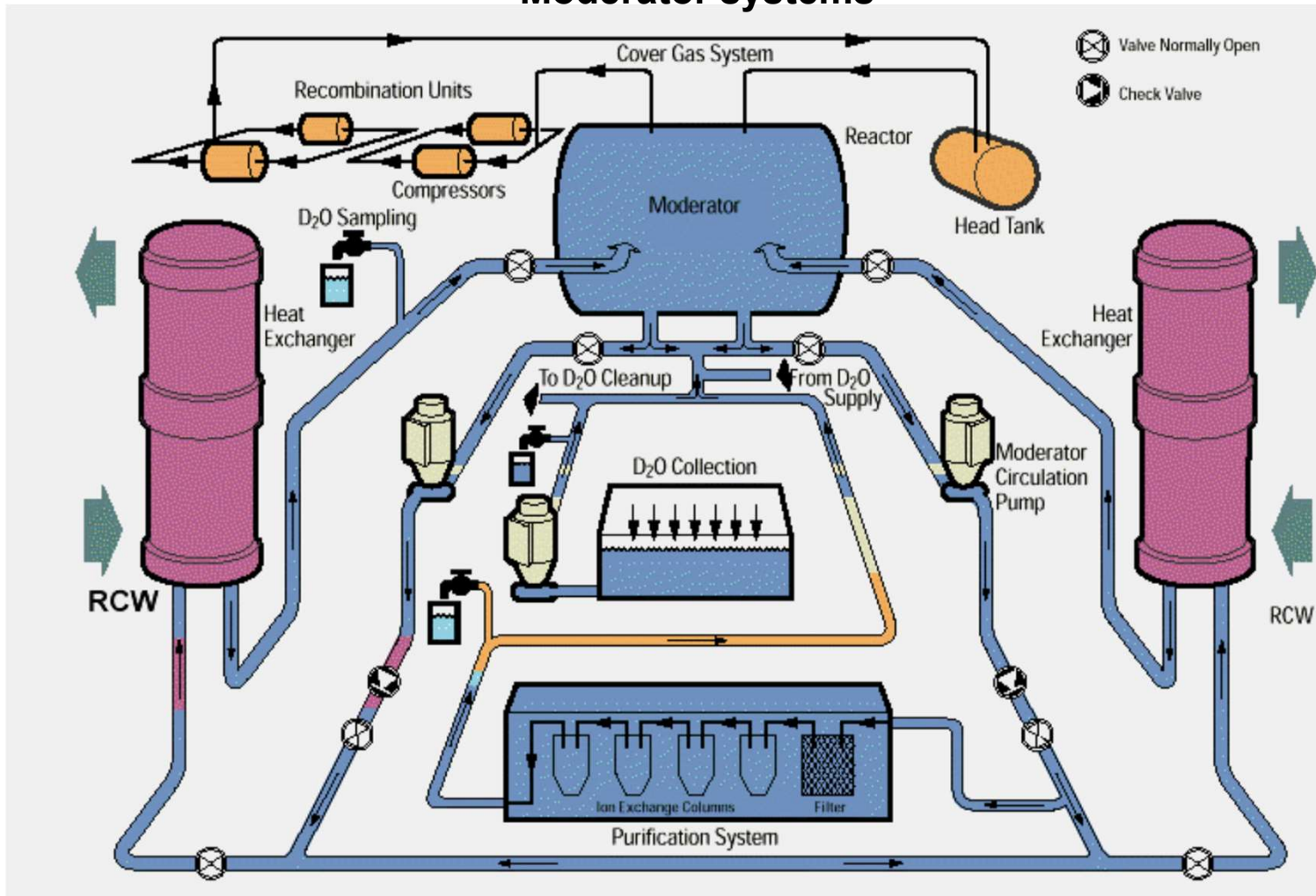

Moderator System

- Low temperature low pressure system
- Independent of the reactor coolant system
- Normal heat removal is approximately 4% of full power
- Potential heat sink if emergency core cooling is not available during LOCA
- Contains shutdown systems outside high pressure heat transport system

CANDU Safety Systems

- Design philosophy- Defense-in-depth with multiple barriers
- Separation of safety systems and safety support systems to increase reliability (diversity and independence)
- Reliable special safety systems

Safety System Functions

- Shutdown the reactor
- Remove the decay heat
- Prevent the release of radioactivity
- Monitor the state of the plant

Special Safety Systems

- Shutdown system 1 (SDS1): Fast acting shutoff rods
- Shutdown system 2 (SDS2): Fast acting Poison injection
- Emergency Core Cooling (ECC)
- Containment (including isolation functions)

Shutdown Systems

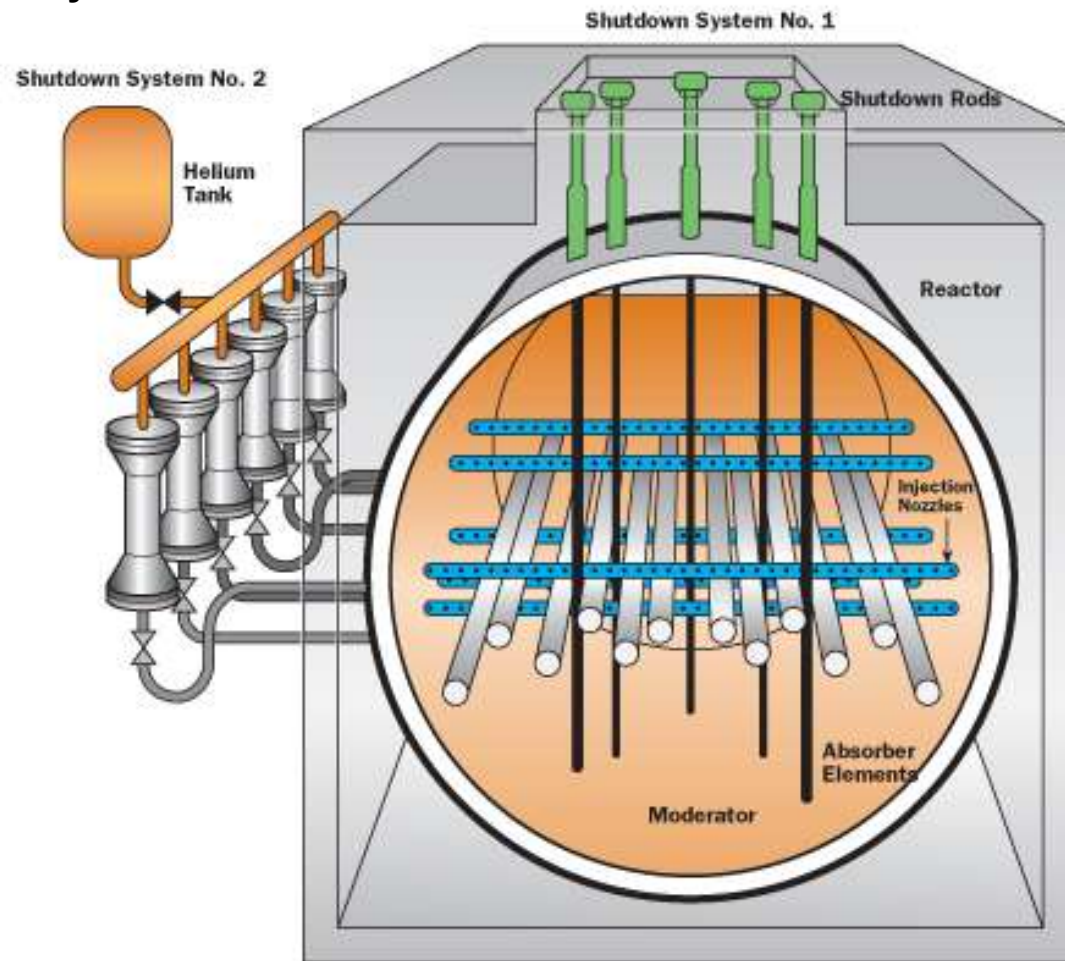

Shutdown System 1

- 28 stainless steel clad cadmium rods
- Vertically oriented and spring assisted gravity drop.
- Independent of SDS 2
- Independent of reactor control (regulating) system

Shutdown System 2

- 6 injection nozzles for gadolinium nitrate solution (poison)
- Horizontal insertion driven by high pressure He.
- Independent of SDS 1
- Independent of reactor control (regulating) system

Removal of Decay Heat

- **With an intact heat transport system**
 - Steam generator + main feed water system, or
 - Steam generator + auxiliary feed water system, or
 - shutdown cooling system
 - Emergency water system
- **With a large break in the HTS**
 - Emergency core cooling
- **For severe accident (ECC failure)**
 - Moderator and shield tank

Emergency Core Cooling (ECC) System

- Injection in all headers of the HTS
- Three stages
 - High pressure injection, water from external tank
 - Medium pressure, water from dousing tank
 - Low pressure, water recirculated from containment sump

ECC High Pressure Operation

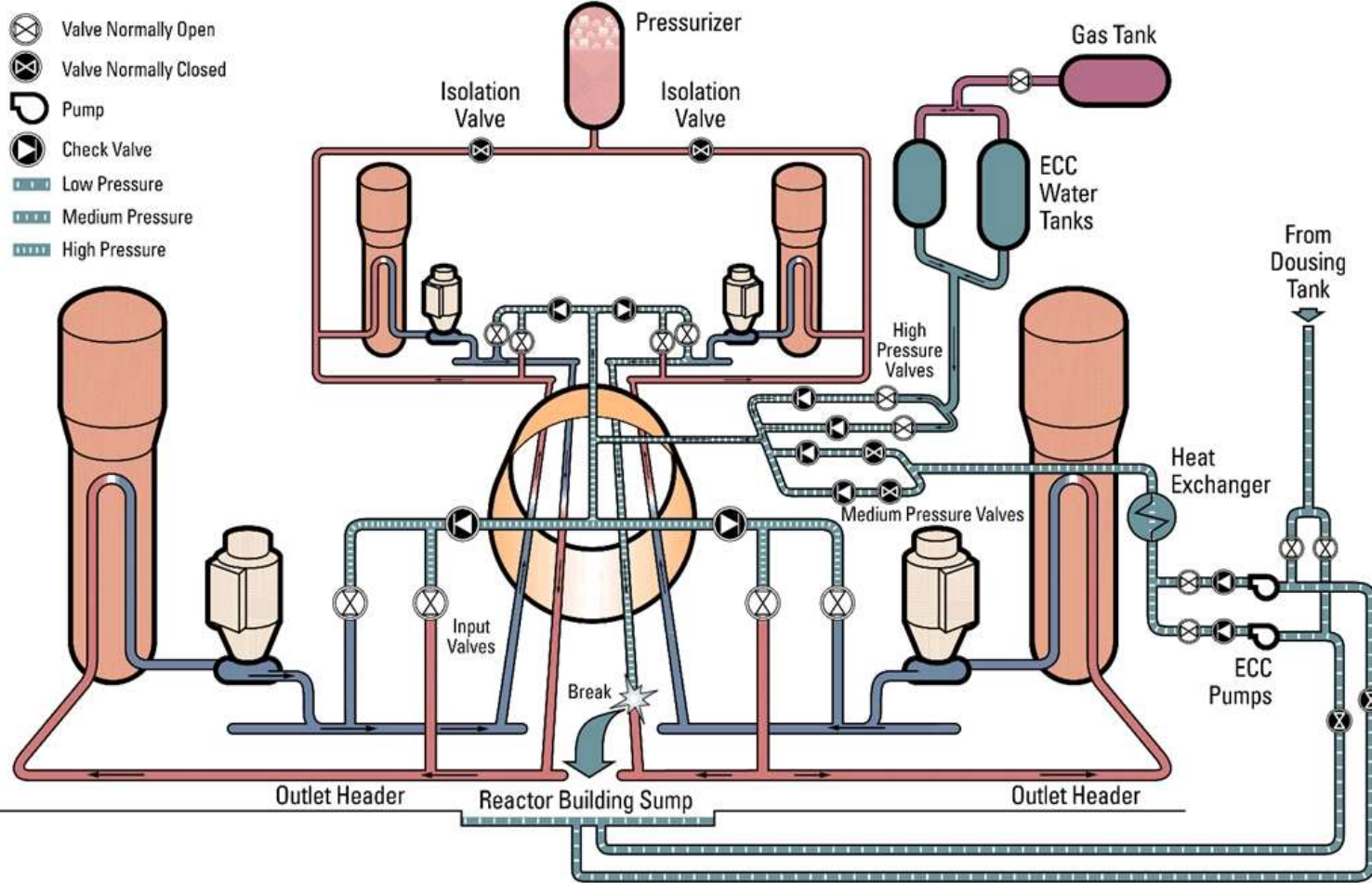

Containment System

- Pre-stressed post-tensioned concrete building with high flow dousing sprays for active pressure suppression.
- Encloses reactor and all of the heat transport system.
- Low leak rate
- Automatic isolation of penetrations in the event of an accident.

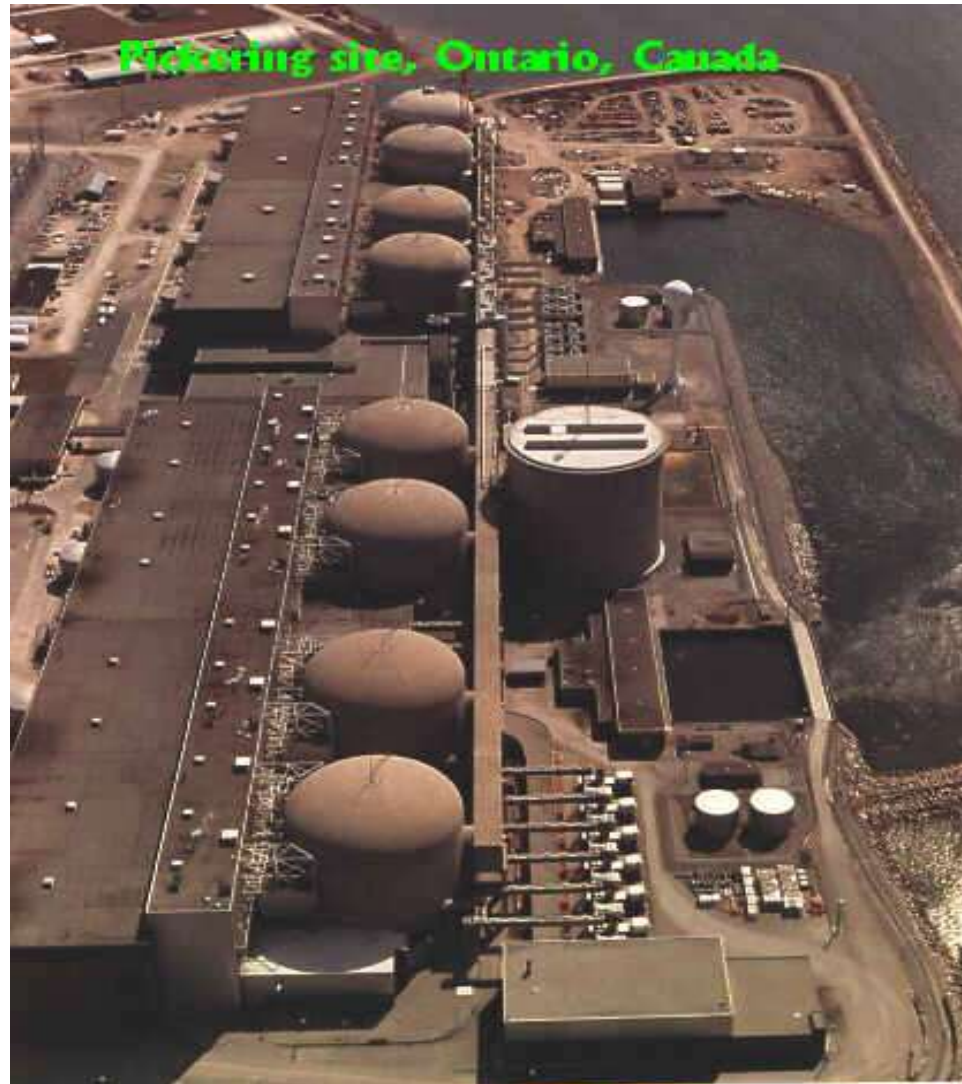

Pickering site, Ontario, Canada

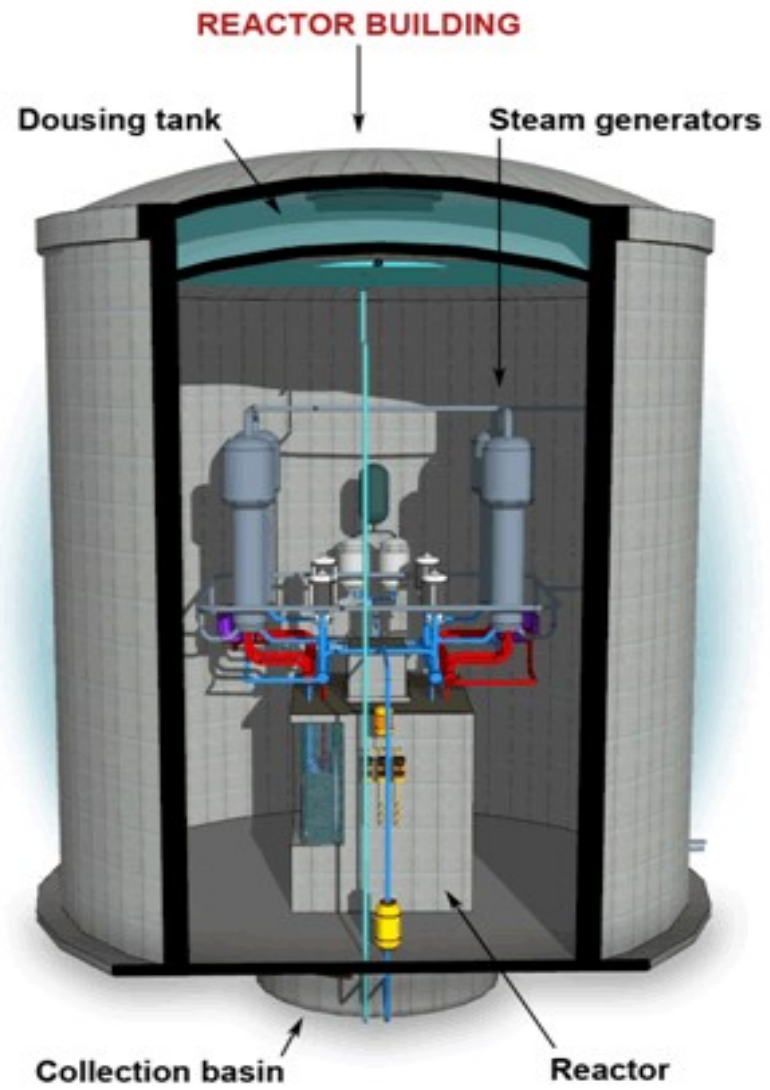





Nuclear Power Plant Safety Systems - YouTube

Understanding Nuclear Power Plants: Total Station Blackout - YouTube

Canada's Operating Power Reactors

Operable status (Average age – 25 Years)

-  In service within design life
-  In service / Returned to service
-  Safe storage state
-  In refurbishment

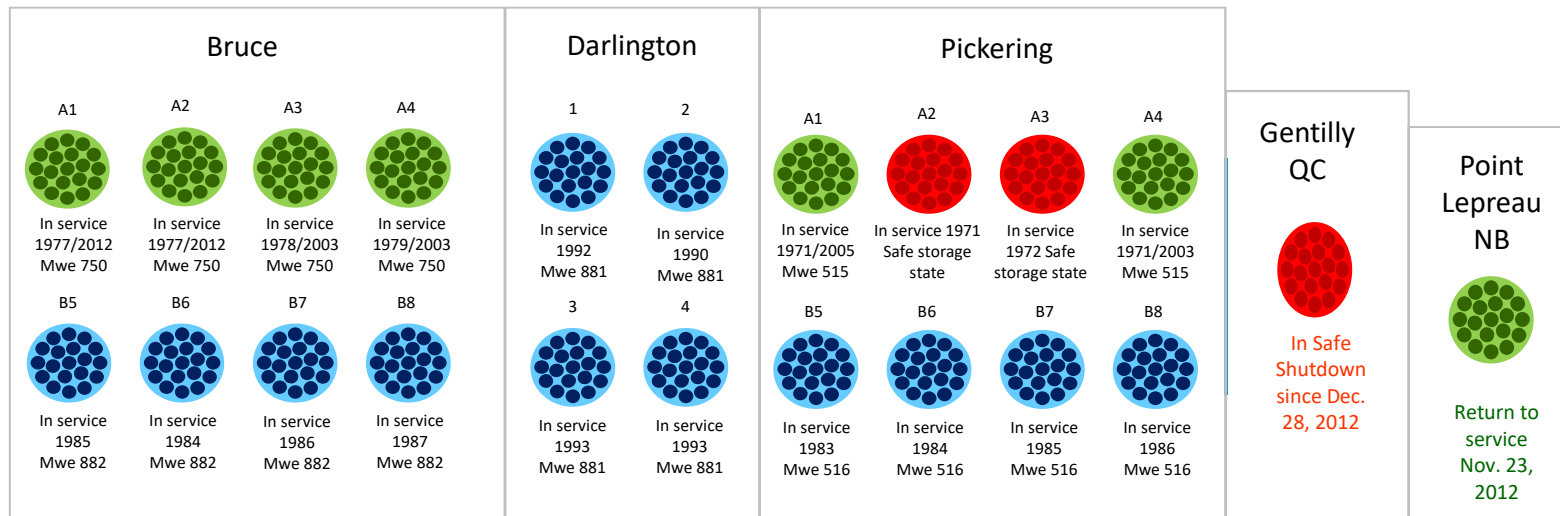

Canada's Nuclear Power Plants- BRUCE Nuclear Generating Station



Bruce Nuclear Generation Station, Bruce A (top), Bruce B (bottom)

Location	Kincardine
Installed Capacity	6,300 MW
Number of Units	8
Operator	Bruce Power
Refurbishment and Continued Operations Schedule	Two units (1 & 2) were refurbished and brought back into service in 2012. The IESO signed an agreement with Bruce Power in December 2015, securing 6,300 MW of electricity and enabling the refurbishment of the remaining six units, beginning in 2020.

Canada's Nuclear Power Plants- Darlington Nuclear Generating Station



Aerial view Darlington Nuclear Generating Station

Location	Clarington
Installed Capacity	3,500 MW
Number of Units	4
Operator	Ontario Power Generation
Refurbishment and Continued Operations Schedule	OPG started the refurbishment of the first unit at the Darlington station in October 2016. Darlington refurbishment is scheduled for completion by 2026.

Canada's Nuclear Power Plants- Pickering Nuclear Generating Station



Location	Pickering
Installed Capacity	3,100 MW
Number of Units	6
Operator	Ontario Power Generation
Refurbishment and Continued Operations Schedule	Two units will be retired at the end of 2022 and four units will be retired at the end of 2024.

Canada's Nuclear Power Plants- Point Lepreau Nuclear Generating Station



Location	Saint John
Installed Capacity	660 MW
Number of Units	1
Operator	New Brunswick Power
Refurbishment and Continued Operations Schedule	Returned to service after refurbishment in 2012. expected to continue supply about 30% of the province electricity.

Aerial view Point Lepreau Nuclear Generating Station

Contribution by Fuel Type in Ontario-2017

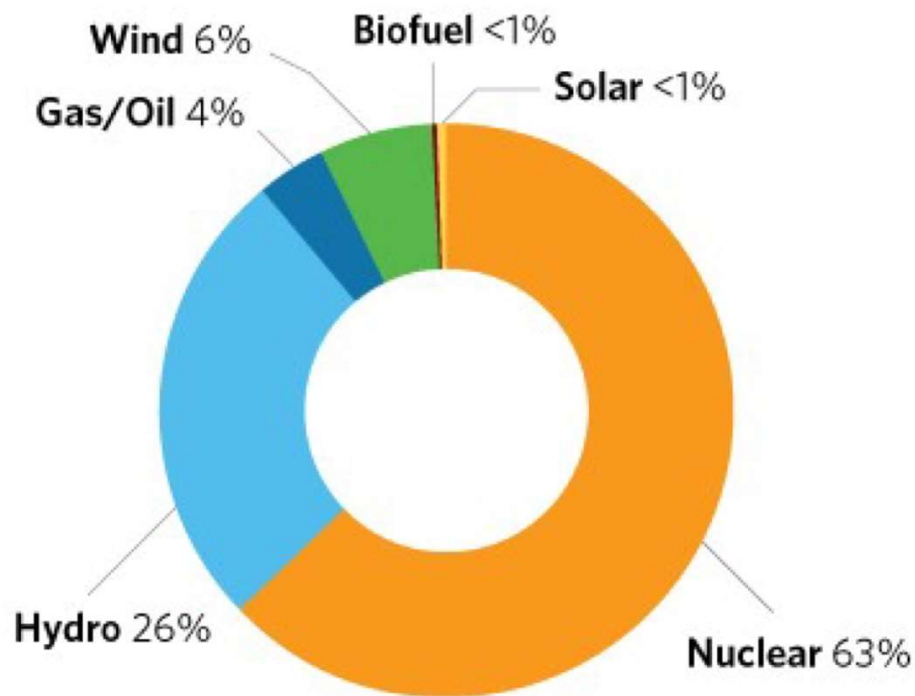

Nuclear	90.6 TWh or 63%
Hydro	37.7 TWh or 26%
Gas/Oil	5.9 TWh or 4%
Wind	9.2 TWh or 6%
Biofuel	0.4 TWh or <1%
Solar	0.5 TWh or <1%

Reactors of the Future

Generations of nuclear power: Time ranges correspond to the design and the first deployments of different generations of reactors

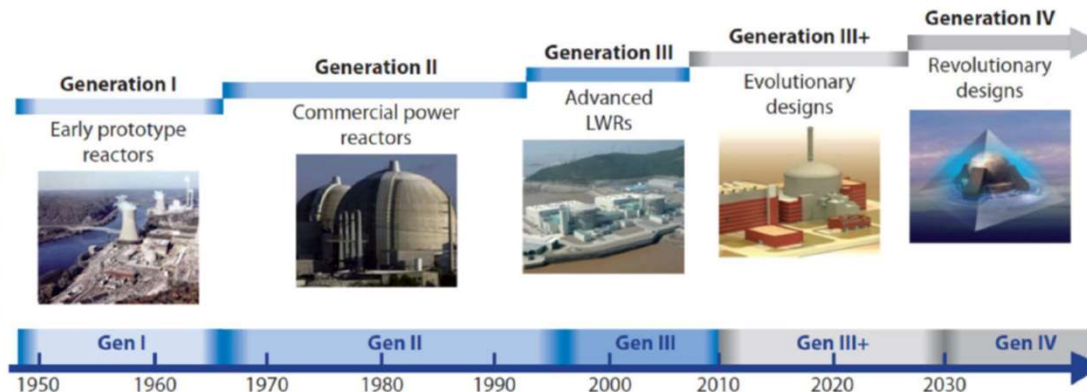

Origins of the GIF
GIF meetings began in 1999. The U.S. Department of Energy, State Department, and representatives from other nations collaborated in the formation of the GIF.

This group, subsequently named the [GIF Policy Group](#), also decided to form a group of senior technical experts to explore areas of mutual interest and make recommendations regarding both research and development areas and processes by which collaboration could be conducted and assessed. This senior Technical [Experts Group](#) first met in April 2000.

(DOE) Office of Environmental and Nuclear Safety

Generations of nuclear power: Time ranges correspond to the design and the first deployments of different generations of reactors

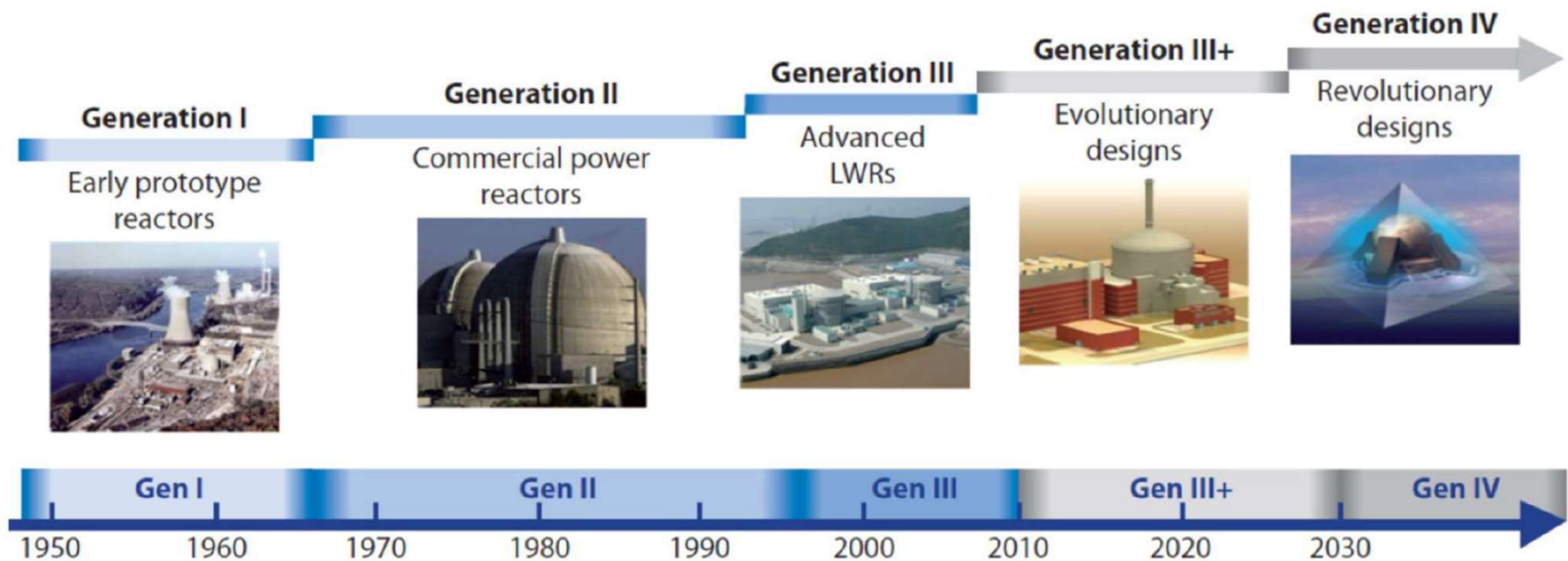

Generations of Nuclear Reactors

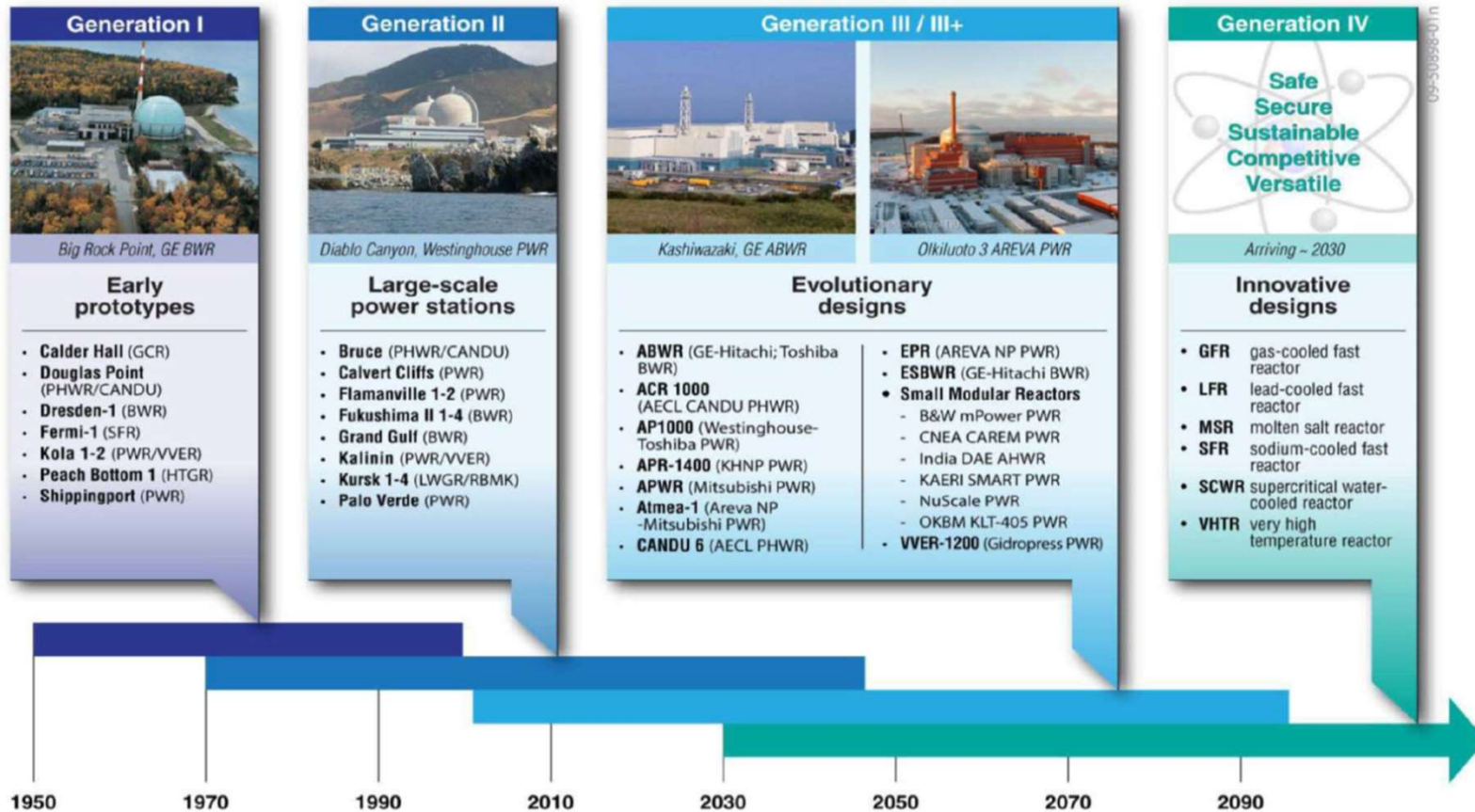

09-5088-0111

Generation IV Systems: Technology Goals

- **Sustainability**
 - Sustainable energy generation through long-term availability of systems and effective fuel utilization
 - Minimize and manage nuclear waste and reduce the stewardship burden in the future
- **Safety & Reliability**
 - Very low likelihood and degree of reactor core damage
 - Eliminate the need for offsite emergency response
- **Economics**
 - Life-cycle cost advantage over other energy sources
 - Level of financial risk comparable to other energy projects
- **Proliferation Resistance & Physical Protection**
 - Unattractive materials diversion pathway
 - Enhanced physical protection against terrorism

With these goals in mind, some 100 experts evaluated 130 reactor concepts before GIF selected six reactor technologies for further R&D. These include:

- the gas-cooled fast reactor (GFR),
- lead-cooled fast reactor (LFR),
- molten salt reactor (MSR),
- Supercritical water-cooled reactor (SCWR),
- sodium-cooled fast reactor (SFR), and
- very high temperature reactor (VHTR).

System development timelines as defined in the original 2002 Roadmap (left) and in the 2013 update

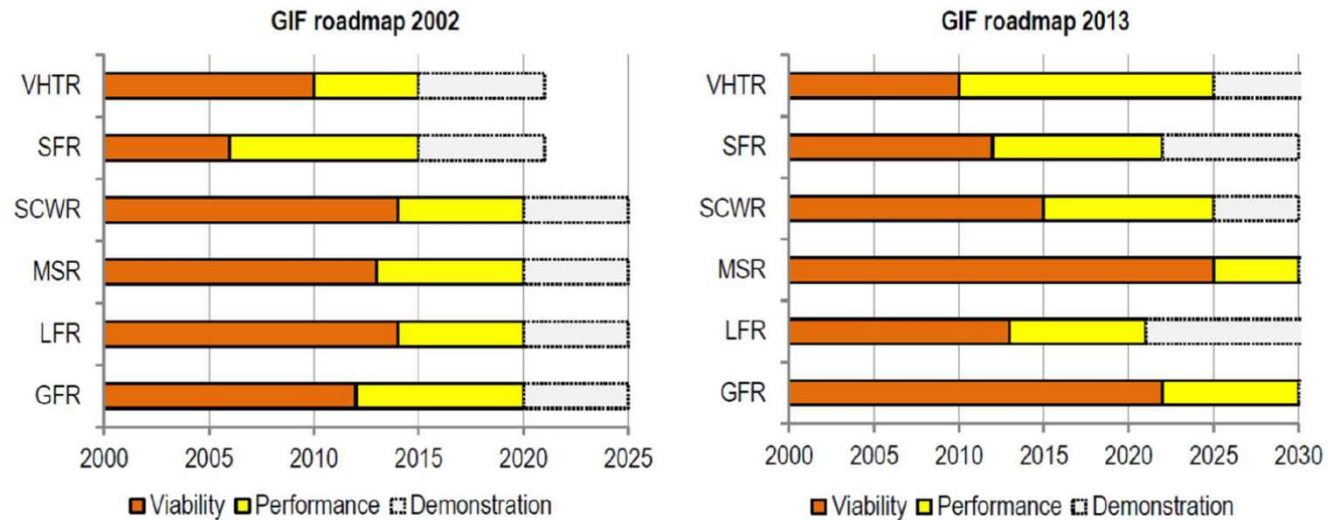

- **The *viability phase***, when basic concepts are tested under relevant conditions and all potential technical show-stoppers are identified and resolved;
- **The *performance phase***, when engineering-scale processes, phenomena and material capabilities are verified and optimized under prototypical conditions;
- **The *demonstration phase***, when detailed design is completed and licensing, construction and operation of the system are carried out, with the aim of bringing it to the commercial deployment stage.

VHTR: Helium gas cooled, graphite-moderated, thermal neutron spectrum reactor with core outlet temperature 900-1000 C (shown with hydrogen cogeneration).

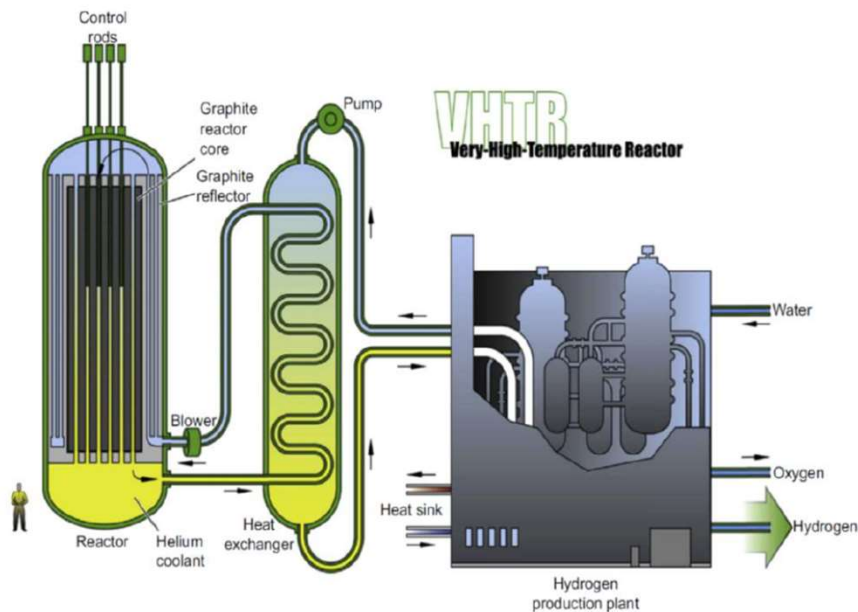

Key objectives for the next 10 years

- In the near future, the main focus will be on VHTR with core outlet temperatures of 700-950°C.
- Further R&D on materials and fuels should enable higher temperatures up to above 1 000°C and a fuel burnup of 150-200 GWd/tHM.
- Development of further approaches to set up high-temperature process heat consortia for end users interested in prototypical demonstrations.
- Development of the interface with industrial heat users – intermediate heat exchanger, ducts, valves and associated heat transfer fluid:
- Advancing H₂ production methods in terms of feasibility and commercial viability to better determine process heat requirements for this application.
- **Regarding nuclear safety:**
 - Verify the effectiveness and reliability of the passive heat removal system.
 - Confirm fuel resistance to extreme temperatures (~1 800°C) through testing.
 - Proceed with the safety analyses of coupled nuclear processes for industrial sites using process heat.

GFR: Helium gas-cooled, fast neutron spectrum reactor with closed fuel cycle and outlet temperature of about 850C (shown with direct gas turbine Brayton power cycle).

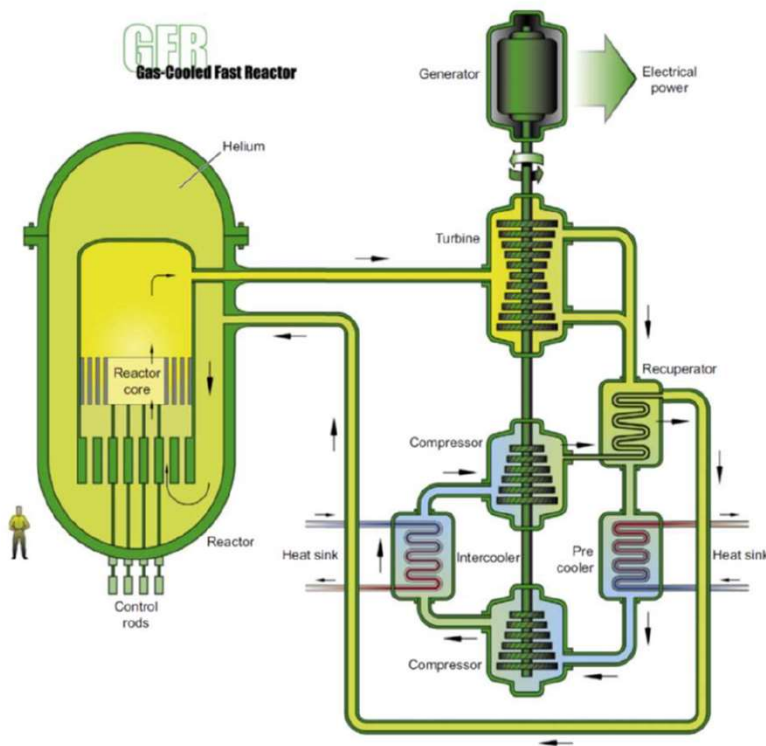

Key objectives for the next 10 years

- Reference concept of 2400 MWth reactor capable of breakeven breeding.
- Improving the design for the safe management of loss-of-coolant accidents including depressurization, and a robust removal of decay heat without external power supply.
- Advancing suitable nuclear fuel technologies with out-of-pile and irradiation experiments.
- Building experimental facilities for qualifying the main components and systems.
- Design studies for a small experimental reactor (e.g. ALLEGRO).

SFR: Molten sodium-cooled, fast neutron spectrum reactor with closed fuel cycle and outlet temperatures within 500-550 C (shown pool-type reactor with indirect steam turbine Rankine power cycle).

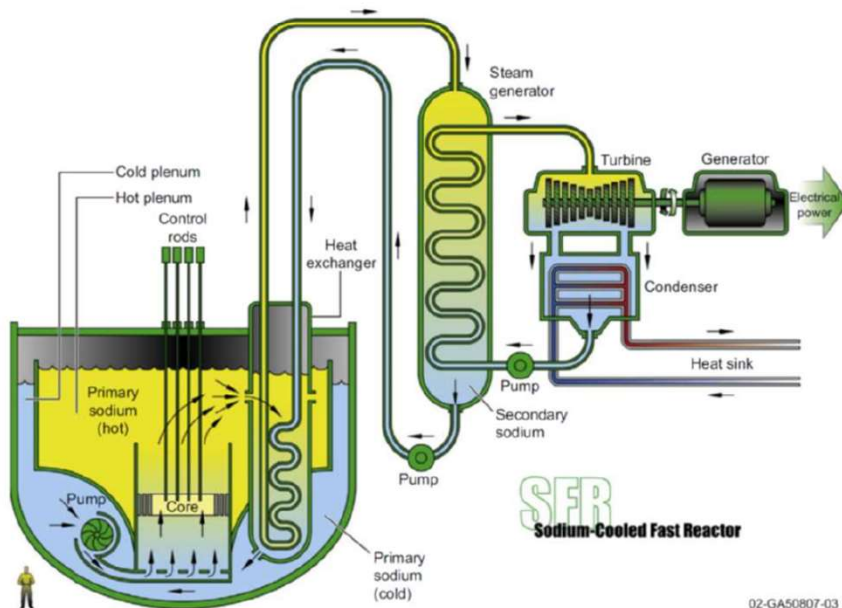

02-GA50807-03

Key objectives for the next 10 years

- Three baseline concepts (pool, loop and modular configurations).
- Several sodium-cooled reactors operational or under construction (e.g. in China, India, Japan and Russia).
- Develop advanced national SFR demonstrators for near-term deployment (France, Japan and Russia); proceed with respective national projects in China, Korea and India.
- In the coming years, the main R&D efforts will be concentrated on:
 - safety and operation (improving core inherent safety and I&C, prevention and mitigation of sodium fires, prevention and mitigation of severe accidents with large energy releases, ultimate heat sink, ISI&R);
 - consolidation of common safety design criteria;
 - advanced fuel development (advanced reactor fuels, MA-bearing fuels);
 - component design and balance of plant (advanced cycles for energy conversion, innovative component design);
 - used fuel handling schemes and technologies;
 - system integration and assessment;
 - implementation of innovative options;
 - economic evaluations, operation optimisation.

LFR: Molten lead-cooled, fast neutron spectrum reactor with closed fuel cycle and outlet temperatures within 500-550C (shown with indirect Brayton power cycle).

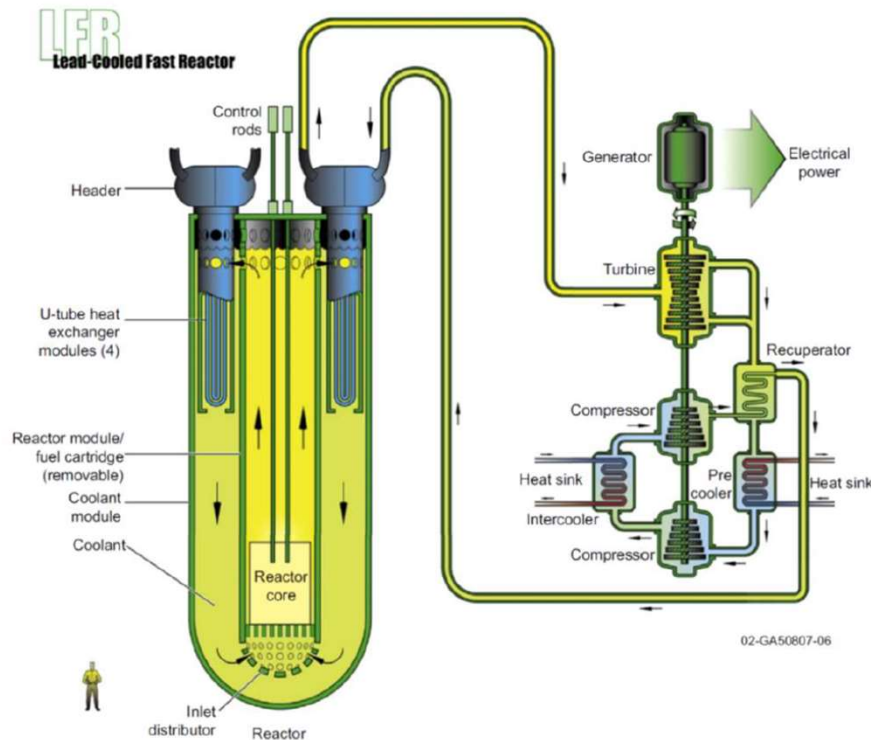

Key objectives for the next 10 years

- Prototypes expected after 2020: Pb-Bi-cooled SVBR-100, BREST-300 in Russia.
- • Proceeding with detailed design and licensing activities.
- • Preliminary analyses of accidental transients including earthquakes and in-vessel steam generator pipe ruptures.
- Main R&D efforts will be concentrated on:
 - materials corrosion and development of a lead chemistry management system;
 - core instrumentation;
 - fuel handling technology and operation;
 - advanced modelling and simulation;
 - fuel development (MOX for first core, then MA-bearing fuels); and possibly nitride fuel for lead-cooled reactors (BREST);
 - actinide management (fuel reprocessing and manufacturing).
 - ISI&R (techniques for opaque medium, seismic impact).

MSR: Molten salt-cooled reactor with outlet temperatures within 700-800C (shown with indirect Brayton power cycle).

Key objectives for the next 10 years

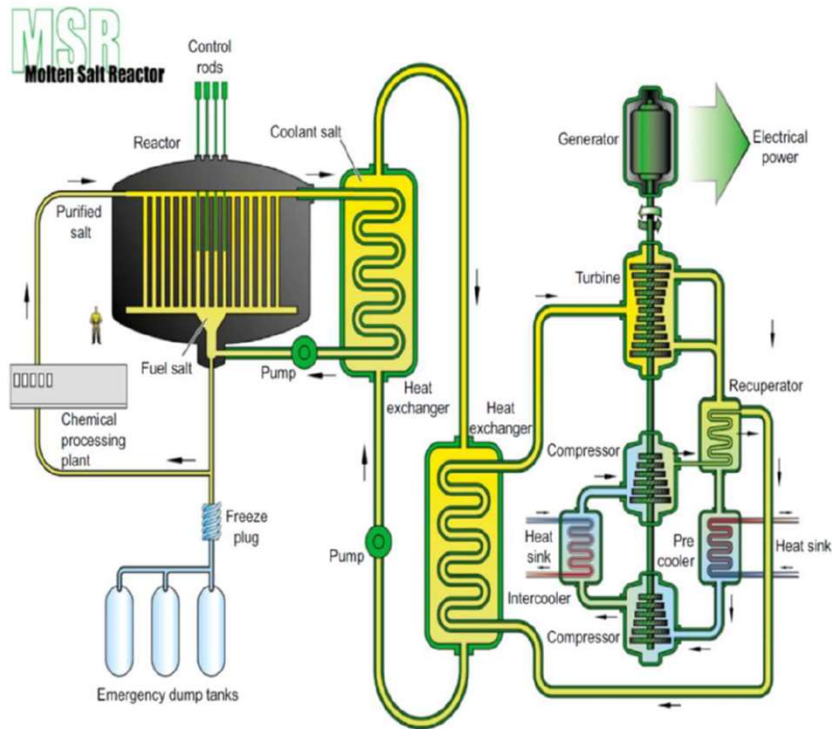

02-GA50807-02

- A baseline concept: the molten salt fast reactor (MSFR).
- Commonalities with other systems using molten salts (FHR, heat transfer systems).
- Further R&D on liquid salt physical chemistry and technology, especially on corrosion, safety-related issues and treatment of used salt

SCWR: Supercritical water-cooled, thermal neutron spectrum reactor with outlet temperatures within 510-625 C (shown with direct steam turbine Rankine power cycle).

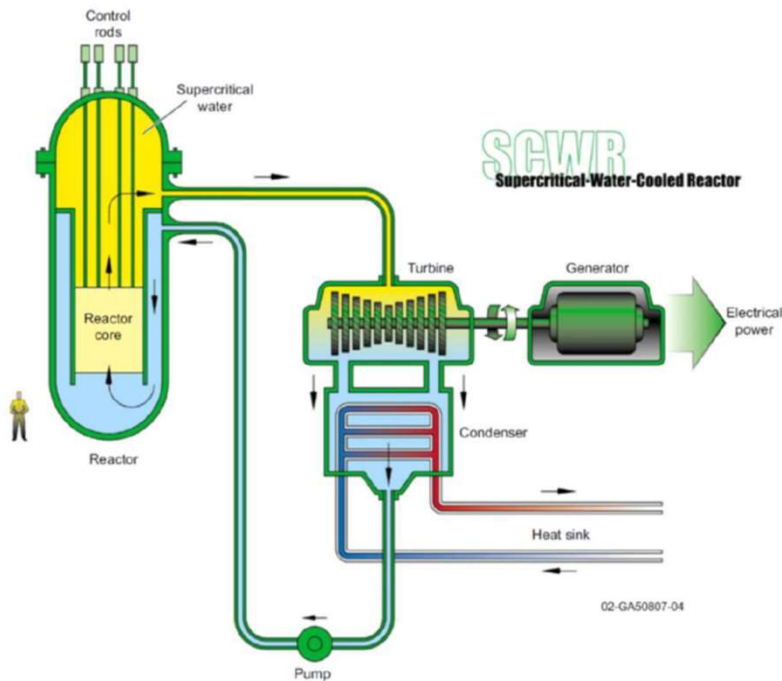

Key objectives for the next 10 years

- Two baseline concepts (pressure-vessel-based and pressure-tube-based).
- R&D over the next decade will include:
 - advancing conceptual designs of baseline concepts and associated safety analyses;
 - more realistic testing of materials to allow final selection and qualification of candidate alloys for all key components;
 - out-of-pile fuel assembly testing;
 - qualification of computational tools;
 - first integral component tests and start of design studies for a prototype;
 - in-pile tests of a small scale fuel assembly in a nuclear reactor.
- Definition of a SCWR prototype (size, design features) for decisions to be taken in the coming years.