



**FINAL  
EXAMINATION  
April 2008**

**DURATION: 3 HOURS**

No. of Students: **170**

Department Name & **Thermodynamics and Heat Transfer – MAAE 2400**

Course Number:

**Course Instructor(s):** I. Beausoleil-Morrison, M. I. Yaras

AUTHORIZED MEMORANDA

8.5 in x 11 in sheet (both sides), standard calculator

**Students MUST count the number of pages in this examination question paper before beginning to write, and report any discrepancy immediately to a proctor. This question paper has X pages.**

**This examination question MAY be taken from the examination room.**

**Answer all 4 questions. The marks for each question are indicated in brackets in the left margin.**

1. Part (a) [20 marks]

[30 marks]

A power plant employing the Rankine cycle and using water as the working fluid produces a net power of 600 MW. The power plant is illustrated in the figure below. Superheated vapour enters the turbine at 12 MPa and 565°C at exits at 6 kPa whereas saturated liquid enters the pump at 6 kPa. The isentropic efficiency of the turbine is 92% and the isentropic efficiency of the pump is 80%.

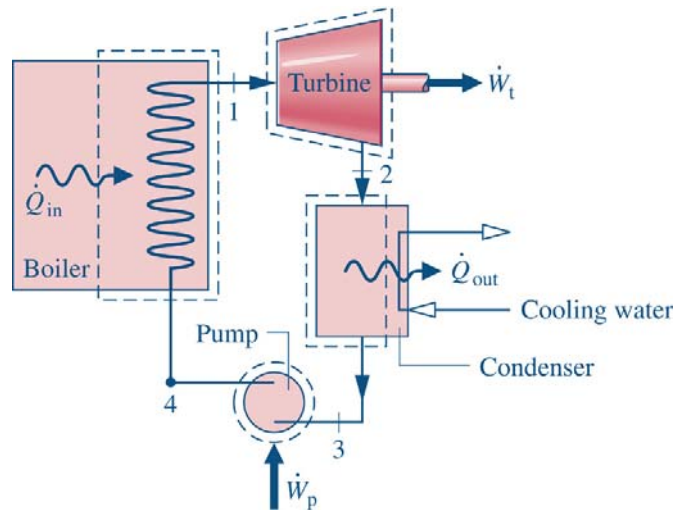

Clearly list all assumptions taken in your analysis and perform the following:

- i) Indicate the state points of the cycle on a T-s diagram. (Note: follow the state point numbering scheme utilized in the above figure.)
- ii) Calculate the specific work input to the pump.
- iii) Calculate the specific work output of the turbine.
- iv) Calculate the specific heat addition rate at the boiler.
- v) Calculate the flow rate of the working fluid.
- vi) Calculate the back work ratio.
- vii) Calculate the thermal efficiency of the cycle.

Part (b) [6 marks]

An adjacent lake is used as the power plant's cold reservoir. This is accomplished by pumping lake water through the cold side of the water-to-water heat exchanger that comprises the condenser (see figure below). The power plant's working fluid flows through the hot side of the condenser. The coolant water is returned to the lake after it is warmed in the condenser. The lake temperature is  $10^{\circ}\text{C}$  and the coolant water returned to the lake is  $25^{\circ}\text{C}$ , this upper value being limited by regulations that protect aquatic life from the power plant's thermal pollution.

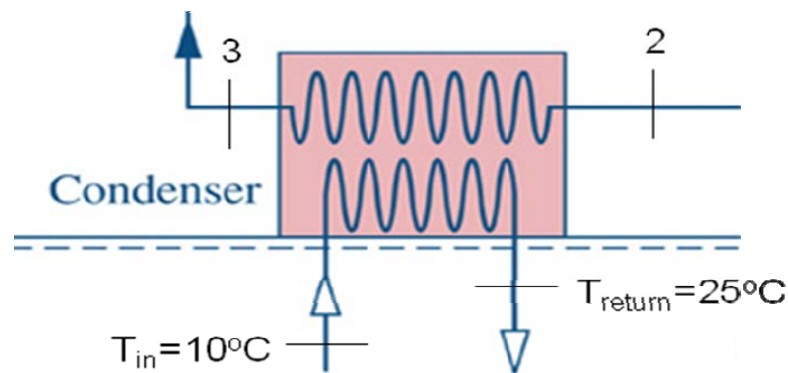

Assuming the lake water to be incompressible, calculate the flow rate of lake water through the condenser. Assume that the lake water's heat capacity is  $c=4.2 \text{ kJ/kgK}$ . Clearly list all assumptions.

Part c) [4 marks]

Calculate the efficiency of a Carnot power cycle that operates between thermal reservoirs at  $10^{\circ}\text{C}$  and  $565^{\circ}\text{C}$ . List all the factors that explain the difference between this Carnot efficiency and the power plant's thermal efficiency as calculated in Part (a).

The power plant's thermal efficiency could be increased by increasing the isentropic efficiencies of the pump and turbine. List two other design changes that could be made to improve the power plant's thermal efficiency and briefly explain (no more than three sentences) in qualitative terms why these measures would increase the efficiency.

- [25 marks]
2. You are asked to design a residential air conditioning system that employs R-22 as the refrigerant. A schematic representation of the cycle is illustrated in the figure below. Effective humidity control in a house dictates that the evaporator temperature be no warmer than  $12^{\circ}\text{C}$ . The condenser is to be located in a courtyard of the house where the air can be as hot as  $39^{\circ}\text{C}$ . Size constraints in the heat exchanger that comprises the condenser requires that there be at least a  $7^{\circ}\text{C}$  temperature difference between the refrigerant within the condenser and the outdoor air.

Given these constraints, you are asked to specify the refrigerant pressures for the evaporator and condenser that will maximize the system's COP.

Clearly list all assumptions taken in your analysis and perform the following:

- Indicate the state points of the cycle on a T-s diagram. (Note: follow the state point numbering scheme utilized in the figure below.)
- Specify the refrigerant pressures for the evaporator and condenser in bar (integer values only).
- Calculate the COP of the air conditioning system. Assume that the compressor is isentropic and that saturated liquid exits the condenser.

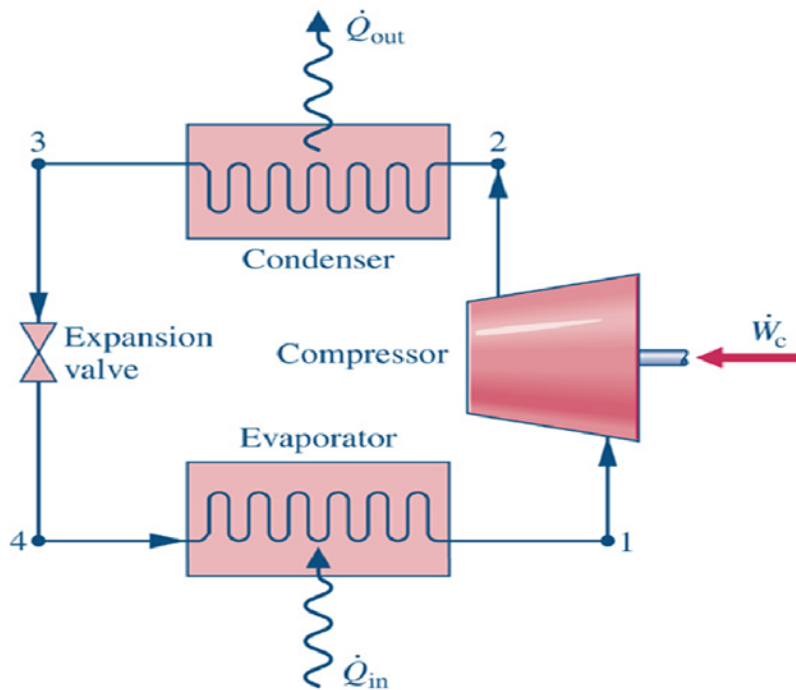

- [25 marks] 3. The wall of a house is constructed of 0.5-in thick wood (pine) siding, 1.5 inch x 3.5 inch wood (pine) studs at 16-inch centres, and 0.5-inch thick gypsum wallboard, as shown in the figure below. The space between the studs is filled with 3.5 inch-thick fiberglass insulation. The convective heat transfer coefficients on the exterior and interior surfaces are  $6.0 \text{ BTU/hr ft}^2\text{F}$  and  $1.3 \text{ BTU/hr ft}^2\text{F}$ , respectively. The inside air temperature is  $68.0^\circ\text{F}$  and the outside air temperature is  $20.0^\circ\text{F}$ . Assuming one-dimensional heat flow through the wall, determine:
- the heat flux from the wall surface;
  - the temperature on the interior surface of the gypsum wallboard;
  - the fraction of the overall heat flux that is transmitted through the 1.5 inch x 3.5 inch wood studs;

Compare the answer of part (a) to the heat flux if the wall of the house were to consist only of wood material, constructed of 7.5-inch thick milled pine logs.

$$k_{\text{FIBERGLASS}} = 0.023 \text{ BTU/hr ft}^\circ\text{F}$$

$$k_{\text{WOOD}} = 0.07 \text{ BTU/hr ft}^\circ\text{F}$$

$$k_{\text{GYPSUM}} = 0.248 \text{ BTU/hr ft}^\circ\text{F}$$

FIGURE FOR QUESTION 4 TO BE PLACED HERE

- [20 marks] 4. Based on your observations in the laboratory sessions of MAAE2400, provide brief

answers (**maximum 2 sentences each**) to the following questions:

- a) What device is used to load the gasoline and diesel engines? What is the basic operation principle of this device?
- b) How is the heat removed from the engine coolant on the gasoline and diesel engines?
- c) How many temperature gauges exist on each of the engine-test consoles? What temperatures are displayed on these gauges?
- d) What type of refrigerant is used in the Carrier Air Conditioning experiment?
- e) What is the physical location of the compressor in relation to the condenser in the Carrier Air Conditioning experiment?
- f) How is the compressor cooled in the Carrier Air Conditioning experiment?
- g) What arrangement is used on the Carrier Air Conditioning experiment to prevent saturated liquid from entering the compressor?
- h) What type of flowmeter is used to measure the flow rate of refrigerant in the Carrier Air Conditioning experiment?
- i) How is the float position in the refrigerant flowmeter identified in the Carrier Air Conditioning experiment, given that the float is not visible?
- j) What types of thermocouples are used to measure the temperatures in the Carrier Air Conditioning experiment?
- k) What type of fuel is used in the Gas Calorimeter experiment?
- l) How is the exhaust products cooled in the Gas Calorimeter experiment?