



Quiz 5

February 11, 2019

CHG 2314

Solution

Consider the fin array shown below in which $w = 20$ mm, $L = 10$ mm, $t = 2$ mm and $S = 5$ mm. The fins are made from made from aluminum ($k = 238$ W/m K) and the base and environment temperatures are $T_b = 80^\circ\text{C}$ and $T_\infty = 20^\circ\text{C}$. The heat transfer coefficient $h = 25$ W/m² K. Contact resistance and radiation effects are negligible. Since fins are relatively short, heat transfer from the tip has to be included.

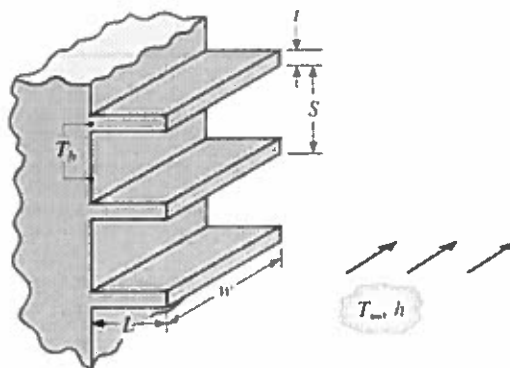

- i) Calculate the efficiency of an individual fin (η_f) (4 points).

$$\eta_f = \frac{\tanh(mL_c)}{mL_c} \quad \text{where } L_c = L + t/2 = 10 + 2/2 = 11 \text{ mm} = 0.011 \text{ m}, \quad m = \sqrt{\frac{hP}{kA_c}} \quad \text{where: } P = 2w + 2t =$$

$$\text{Sub-in numerical values: } m = \sqrt{\frac{25 \cdot 0.044}{238 \cdot 4 \cdot 10^{-5}}} = 10.75 \frac{1}{\text{m}}$$

$$\eta_f = \frac{\tanh(10.75 \cdot 0.011)}{10.75 \cdot 0.011} = 0.995 \blacktriangleleft$$

$$\begin{aligned} &= 2 \cdot 20 + 2 \cdot 2 = 44 \text{ mm} \\ &= 0.044 \text{ m} \\ A_c &= t \cdot w = \\ &= 0.002 \cdot 0.02 \\ &= 4.0 \cdot 10^{-5} \text{ m}^2 \end{aligned}$$

- ii) Calculate the efficiency of finned surface (η_o) (4 points).

$$\eta_o = 1 - \frac{N' A_f}{A_b'} (1 - \eta_f) \quad \text{where } N' = \text{number fins per unit length (height)}, \quad N' = \frac{1}{S} = \frac{1}{0.005} = 200 \frac{1}{\text{m}}$$

$$A_f = P \cdot L_c = 0.044 \cdot 0.011 = 4.84 \cdot 10^{-4} \text{ m}^2$$

Sub-in numerical values

$$\begin{aligned} A_b' &= N' A_f + A_b = 200 \cdot 4.84 \cdot 10^{-4} + w(1 - N't) = \\ &= 0.0968 + 0.02 \cdot (1 - 200 \cdot 0.002) = 0.1088 \text{ m} \end{aligned}$$

$$\eta_o = 1 - \frac{200 \cdot 4.84 \cdot 10^{-4}}{0.1088} (1 - 0.995) = 0.996 \blacktriangleleft$$

- iii) Calculate the rate of heat transfer from this fin array per unit height (q') (2 points).

$$q' = \frac{T_b - T_\infty}{R'_{t,o}} = \eta_o h A_b' (T_b - T_\infty) = 0.996 \cdot 25 \cdot 0.1088 (80 - 20) = 162.5 \left[\frac{\text{W}}{\text{m}} \right] \blacktriangleleft$$