

A First Course in

LINEAR ALGEBRA

Lecture Notes

by Karen Seyffarth

Systems of Linear Equations

Creative Commons License (CC BY-NC-SA)



Champions of Access to Knowledge



OPEN TEXT



ONLINE
ASSESSMENT



SUPPORT



INSTRUCTOR
SUPPLEMENTS

Contact Lyryx Today!

info@lyryx.com

A First Course in Linear Algebra

Lecture Notes

Current Lecture Notes Revision: Version 2017 — Revision A

These lecture notes were originally developed by Karen Seyffarth of the University of Calgary. Edits, additions, and revisions have been made to these notes by the editorial team at Lyryx Learning to accompany their text [A First Course in Linear Algebra](#) based on K. Kuttler's original text.

In addition we recognize the following contributors. All new content contributed is released under the same license as noted below.

- Ilijas Farah, York University
- Ken Kuttler, Brigham Young University
- Asia Weiss, York University

BE A CHAMPION OF OER!

Contribute suggestions for improvements, new content, or errata:

A new topic

A new example or problem

A new or better proof to an existing theorem

Any other suggestions to improve the material

Contact Lyryx at info@lyryx.com with your ideas.

License



Attribution-NonCommercial-ShareAlike (CC BY-NC-SA)

This license lets others remix, tweak, and build upon your work non-commercially, as long as they credit you and license their new creations under the identical terms.

Motivation

Example

Find all solutions of the (linear) equation in one variable:

$$ax = b$$

Solution

- If $a \neq 0$, there is a unique solution $x = b/a$.
- Else if $a = 0$ and
 - ▶ $b \neq 0$, there is no solution.
 - ▶ $b = 0$, there are infinitely many solutions, in fact any $x \in \mathbb{R}$ is a solution.

This a complete description of all possible solutions of $ax = b$.

Objective:

Can we do the same for linear equations in more variables?

Definitions

A *linear equation* is an expression

$$a_1x_1 + a_2x_2 + \cdots + a_nx_n = b$$

where $n \geq 1$, a_1, \dots, a_n are real numbers, *not all of them equal to zero*, and b is a real number.

A *system of linear equations* is a set of $m \geq 1$ linear equations. It is not required that $m = n$.

Solution to a system of m equations in n variables is an n -tuple of numbers that satisfy each of the equations.

Solve a system means 'find *all* solutions to the system.'

Systems of Linear Equations

Example

A system of linear equations:

$$\begin{aligned}x_1 - 2x_2 - 7x_3 &= -1 \\ -x_1 + 3x_2 + 6x_3 &= 0\end{aligned}$$

- variables: x_1, x_2, x_3 .
- coefficients:

$$\begin{aligned}1x_1 - 2x_2 - 7x_3 &= -1 \\ -1x_1 + 3x_2 + 6x_3 &= 0\end{aligned}$$

- constant terms:

$$\begin{aligned}x_1 - 2x_2 - 7x_3 &= -1 \\ -x_1 + 3x_2 + 6x_3 &= 0\end{aligned}$$

Example (continued)

$x_1 = -3$, $x_2 = -1$, $x_3 = 0$ is a **solution** to the system

$$\begin{array}{rclcrcl} x_1 & - & 2x_2 & - & 7x_3 & = & -1 \\ -x_1 & + & 3x_2 & + & 6x_3 & = & 0 \end{array}$$

because

$$\begin{array}{rclcrcl} (-3) & - & 2(-1) & - & 7 \cdot 0 & = & -1 \\ -(-3) & + & 3(-1) & + & 6 \cdot 0 & = & 0. \end{array}$$

Another solution to the system is $x_1 = 6$, $x_2 = 0$, $x_3 = 1$ (check!).

However, $x_1 = -1$, $x_2 = 0$, $x_3 = 0$ is **not** a solution to the system, because

$$\begin{array}{rclcrcl} (-1) & - & 2 \cdot 0 & - & 7 \cdot 0 & = & -1 \\ -(-1) & + & 3 \cdot 0 & + & 6 \cdot 0 & = & 1 \neq 0 \end{array}$$

A solution to the system must be a solution to **every equation** in the system.

The system above is **consistent**, meaning that the system has **at least one** solution.

Example (continued)

$$\begin{aligned}x_1 + x_2 + x_3 &= 0 \\x_1 + x_2 + x_3 &= -8\end{aligned}$$

is an example of an **inconsistent** system, meaning that it has no solutions.

Why are there no solutions?

Graphical Solutions

Example

Consider the system of linear equations in two variables

$$x + y = 3$$

$$y - x = 5$$

A solution to this system is a pair (x, y) satisfying both equations. Since each equation corresponds to a line, a solution to the system corresponds to a point that lies on both lines, so the solutions to the system can be found by graphing the two lines and determining where they intersect.

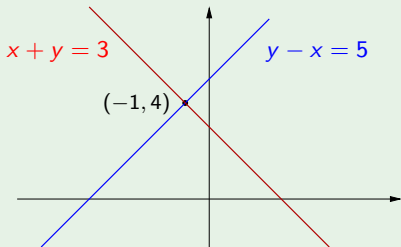

Given a system of two equations in two variables, graphed on the xy -coordinate plane, there are three possibilities, as illustrated below.

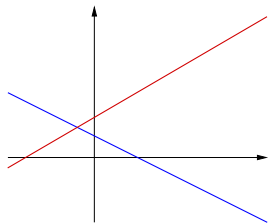

intersect in one point
consistent
(unique solution)

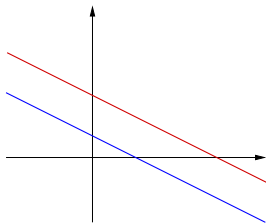

parallel but different
inconsistent
(no solutions)

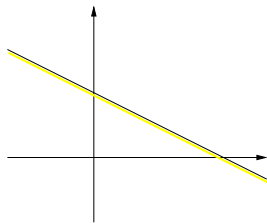

line are the same
consistent
(infinitely many solutions)

For a system of linear equations in **two variables**, exactly one of the following holds:

- 1 the system is **inconsistent**;
- 2 the system has a **unique** solution, i.e., exactly one solution;
- 3 the system has **infinitely many** solutions.

(We will see in what follows that this generalizes to systems of linear equations in more than two variables.)

Example

The system of linear equations in three variables that we saw earlier

$$\begin{aligned}x_1 - 2x_2 - 7x_3 &= -1 \\ -x_1 + 3x_2 + 6x_3 &= 0,\end{aligned}$$

has solutions $x_1 = -3 + 9s$, $x_2 = -1 + s$, $x_3 = s$ where s is any real number (written $s \in \mathbb{R}$).

Verify this by substituting the expressions for x_1 , x_2 , and x_3 into the two equations.

s is called a **parameter**, and the expression

$$x_1 = -3 + 9s, x_2 = -1 + s, x_3 = s, \text{ where } s \in \mathbb{R}$$

is called the **general solution** in parametric form.

Problem

Find all solutions to a system of m linear equations in n variables, i.e., **solve a system of linear equations**.

Definition

Two systems of linear equations are **equivalent** if they have **exactly the same** solutions.

Example

The two systems of linear equations

$$\begin{array}{rcl} 2x + y & = & 2 \\ 3x & = & 3 \end{array} \quad \text{and} \quad \begin{array}{rcl} x + y & = & 1 \\ & & y = 0 \end{array}$$

are **equivalent** because both systems have the unique solution $x = 1$, $y = 0$.

Elementary Operations

We solve a system of linear equations by using *Elementary Operations* to transform the system into an equivalent but simpler system from which the solution can be easily obtained.

Three types of Elementary Operations

- **Type I:** Interchange two equations, $r_1 \leftrightarrow r_2$.
- **Type II:** Multiply an equation by a nonzero number, $13r_1$.
- **Type III:** Add a multiple of one equation to a different equation, $3r_3 + r_2$.

Elementary Operations

Example

Consider the system of linear equations

$$\begin{array}{rcccccc} 3x_1 & - & 2x_2 & - & 7x_3 & = & -1 \\ -x_1 & + & 3x_2 & + & 6x_3 & = & 1 \\ 2x_1 & & & & -x_3 & = & 3 \end{array}$$

- Interchange first two equations (Type I elementary operation):

$$\begin{array}{rcccccc} -x_1 & + & 3x_2 & + & 6x_3 & = & 1 \\ r_1 \leftrightarrow r_2 & & & & & & \\ 3x_1 & - & 2x_2 & - & 7x_3 & = & -1 \\ 2x_1 & & & & -x_3 & = & 3 \end{array}$$

- Multiply first equation by -2 (Type II elementary operation):

$$\begin{array}{rcccccc} -6x_1 & + & 4x_2 & + & 14x_3 & = & 2 \\ -2r_1 & & & & & & \\ -x_1 & + & 3x_2 & + & 6x_3 & = & 1 \\ 2x_1 & & & & -x_3 & = & 3 \end{array}$$

- Add 3 times the second equation to the first equation (Type III elementary operation):

$$\begin{array}{rcccccc} & & & & 7x_2 & + & 11x_3 & = & 2 \\ 3r_2 + r_1 & & & & & & & & \\ -x_1 & + & 3x_2 & + & 6x_3 & = & 1 \\ 2x_1 & & & & -x_3 & = & 3 \end{array}$$

Theorem (Elementary Operations and Solutions)

If an elementary operation is performed on a system of linear equations, the resulting system of linear equations is equivalent to the original system. (As a consequence, performing a sequence of elementary operations on a system of linear equations results in an equivalent system of linear equations.)

Solving a System using Back Substitution

Problem

Solve the system using back substitution

$$2x + y = 4$$

$$x - 3y = 1$$

Solution

Add (-2) times the second equation to the first equation.

$$2x + y + (-2)x - (-2)(3)y = 4 + (-2)1$$

$$x - 3y = 1$$

The result is an equivalent system

$$7y = 2$$

$$x - 3y = 1$$

Solution (continued)

The first equation of the system,

$$7y = 2$$

can be rearranged to give us

$$y = \frac{2}{7}.$$

Substituting $y = \frac{2}{7}$ into second equation:

$$x - 3y = x - 3\left(\frac{2}{7}\right) = 1,$$

and simplifying, gives us

$$x = 1 + \frac{6}{7} = \frac{13}{7}.$$

Therefore, the solution is $x = 13/7, y = 2/7$.

The method illustrated in this example is called **back substitution**.

We shall describe an *algorithm* for solving any given system of linear equations.

The Augmented Matrix

Represent a system of linear equations with its augmented matrix.

Example

The system of linear equations

$$\begin{array}{rclclcl} x_1 & - & 2x_2 & - & 7x_3 & = & -1 \\ -x_1 & + & 3x_2 & + & 6x_3 & = & 0 \end{array}$$

is represented by the **augmented matrix**

$$\left[\begin{array}{ccc|c} 1 & -2 & -7 & -1 \\ -1 & 3 & 6 & 0 \end{array} \right]$$

(A **matrix** is a rectangular array of numbers.)

Note. Two other **matrices** associated with a system of linear equations are the **coefficient matrix** and the **constant matrix**.

$$\left[\begin{array}{ccc} 1 & -2 & -7 \\ -1 & 3 & 6 \end{array} \right], \left[\begin{array}{c} -1 \\ 0 \end{array} \right]$$

Elementary Row Operations

For convenience, instead of performing **elementary operations** on a system of linear equations, perform corresponding **elementary row operations** on the corresponding **augmented matrix**.

Type I: Interchange two rows.

Example

Interchange rows 1 and 3.

$$\left[\begin{array}{cccc|c} 2 & -1 & 0 & 5 & -3 \\ -2 & 0 & 3 & 3 & -1 \\ 0 & 5 & -6 & 1 & 0 \\ 1 & -4 & 2 & 2 & 2 \end{array} \right] \xrightarrow{r_1 \leftrightarrow r_3} \left[\begin{array}{cccc|c} 0 & 5 & -6 & 1 & 0 \\ -2 & 0 & 3 & 3 & -1 \\ 2 & -1 & 0 & 5 & -3 \\ 1 & -4 & 2 & 2 & 2 \end{array} \right]$$

Elementary Row Operations

Type II: Multiply a row by a nonzero number.

Example

Multiply row 4 by 2.

$$\left[\begin{array}{cccc|c} 2 & -1 & 0 & 5 & -3 \\ -2 & 0 & 3 & 3 & -1 \\ 0 & 5 & -6 & 1 & 0 \\ 1 & -4 & 2 & 2 & 2 \end{array} \right] \xrightarrow{2r_4} \left[\begin{array}{cccc|c} 2 & -1 & 0 & 5 & -3 \\ -2 & 0 & 3 & 3 & -1 \\ 0 & 5 & -6 & 1 & 0 \\ 2 & -8 & 4 & 4 & 4 \end{array} \right]$$

Elementary Row Operations

Type III: Add a multiple of one row to a different row.

Example

Add 2 times row 4 to row 2.

$$\left[\begin{array}{cccc|c} 2 & -1 & 0 & 5 & -3 \\ -2 & 0 & 3 & 3 & -1 \\ 0 & 5 & -6 & 1 & 0 \\ 1 & -4 & 2 & 2 & 2 \end{array} \right] \xrightarrow{2r_4+r_2} \left[\begin{array}{cccc|c} 2 & -1 & 0 & 5 & -3 \\ 0 & -8 & 7 & 7 & 3 \\ 0 & 5 & -6 & 1 & 0 \\ 1 & -4 & 2 & 2 & 2 \end{array} \right]$$

Definition

Two matrices A and B are **row equivalent** (or simply equivalent) if one can be obtained from the other by a sequence of **elementary row operations**.

Problem

Prove that A can be obtained from B by a sequence of elementary row operations if and only if B can be obtained from A by a sequence of elementary row operations.

Prove that row equivalence is an equivalence relation.

Row-Echelon Matrix

- All rows consisting entirely of zeros are at the bottom.
- The first nonzero entry in each nonzero row is a 1 (called the **leading 1** for that row).
- Each leading 1 is to the right of all leading 1's in rows above it.

Example

$$\begin{bmatrix} 0 & 1 & * & * & * & * & * & * \\ 0 & 0 & 0 & 1 & * & * & * & * \\ 0 & 0 & 0 & 0 & 1 & * & * & * \\ 0 & 0 & 0 & 0 & 0 & 0 & 0 & 1 \\ 0 & 0 & 0 & 0 & 0 & 0 & 0 & 0 \\ 0 & 0 & 0 & 0 & 0 & 0 & 0 & 0 \end{bmatrix}$$

where * can be any number.

A matrix is said to be in the *row-echelon form* (REF) if it a row-echelon matrix.

Reduced Row-Echelon Matrix

- Row-echelon matrix.
- Each leading 1 is the only nonzero entry in its column.

Example

$$\begin{bmatrix} 0 & 1 & * & 0 & 0 & * & * & 0 \\ 0 & 0 & 0 & 1 & 0 & * & * & 0 \\ 0 & 0 & 0 & 0 & 1 & * & * & 0 \\ 0 & 0 & 0 & 0 & 0 & 0 & 0 & 1 \\ 0 & 0 & 0 & 0 & 0 & 0 & 0 & 0 \\ 0 & 0 & 0 & 0 & 0 & 0 & 0 & 0 \end{bmatrix}$$

where * can be any number.

A matrix is said to be in the *reduced row-echelon form* (RREF) if it a row-echelon matrix.

Examples

Which of the following matrices are in the REF?

Which ones are in the RREF?

$$\begin{aligned} \text{(a)} & \begin{bmatrix} 0 & 1 & 2 & 0 \\ 0 & 0 & 1 & 2 \end{bmatrix}, \text{(b)} \begin{bmatrix} 1 & 0 & 2 & 0 \\ 0 & 0 & 1 & 2 \end{bmatrix}, \text{(c)} \begin{bmatrix} 1 & 0 & 2 & 0 \\ 0 & 0 & 1 & 2 \\ 0 & 0 & 1 & 2 \end{bmatrix} \\ \text{(d)} & \begin{bmatrix} 1 & 0 & 2 & 0 \\ 0 & 1 & 1 & 2 \end{bmatrix}, \text{(e)} \begin{bmatrix} 1 & 2 & 0 & 0 \\ 0 & 0 & 1 & 2 \end{bmatrix}, \text{(f)} \begin{bmatrix} 1 & 2 & 0 & 0 \\ 0 & 0 & 1 & 0 \\ 0 & 0 & 0 & 1 \end{bmatrix}, \end{aligned}$$

Example

Suppose that the following matrix is the augmented matrix of a system of linear equations. We see from this matrix that the system of linear equations has four equations and seven variables.

$$\left[\begin{array}{ccccccc|c} 1 & -3 & 4 & -2 & 5 & -7 & 0 & 4 \\ 0 & 0 & 1 & 8 & 0 & 3 & -7 & 0 \\ 0 & 0 & 0 & 1 & 1 & -1 & 0 & -1 \\ 0 & 0 & 0 & 0 & 0 & 0 & 1 & 2 \end{array} \right]$$

Note that the matrix is a **row-echelon matrix**.

- Each column of the matrix corresponds to a variable, and the **leading variables** are the variables that correspond to columns containing leading ones (in this case, columns 1, 3, 4, and 7).
- The remaining variables (corresponding to columns 2, 5 and 6) are called **non-leading variables**.

We will use elementary row operations to transform a matrix to row-echelon (REF) or reduced row-echelon form (RREF).

Solving Systems of Linear Equations

“Solving a system of linear equations” **means** finding **all** solutions to the system.

Method I: Gauss-Jordan Elimination

- 1 Use elementary row operations to transform the augmented matrix to an equivalent (**not equal**) **reduced row-echelon** matrix. The procedure for doing this is called the **Gaussian Algorithm**, or the **Reduced Row-Echelon Form Algorithm**.
- 2 If a row of the form $[0 \ 0 \ \cdots \ 0 \ | \ 1]$ occurs, then there is no solution to the system of equations.
- 3 Otherwise assign **parameters** to the **non-leading variables** (if any), and solve for the **leading variables** in terms of the parameters.

Gauss-Jordan Elimination

Problem

$$\begin{array}{rclcrcl} \text{Solve the system} & 2x & + & y & + & 3z & = & 1 \\ & 2y & - & z & + & x & = & 0 \\ & 9z & + & x & - & 4y & = & 2 \end{array}$$

Solution

$$\begin{aligned} & \left[\begin{array}{ccc|c} 2 & 1 & 3 & 1 \\ 1 & 2 & -1 & 0 \\ 1 & -4 & 9 & 2 \end{array} \right] \xrightarrow{r_1 \leftrightarrow r_2} \left[\begin{array}{ccc|c} 1 & 2 & -1 & 0 \\ 2 & 1 & 3 & 1 \\ 1 & -4 & 9 & 2 \end{array} \right] \\ & \xrightarrow{-2r_1+r_2, -r_1+r_3} \left[\begin{array}{ccc|c} 1 & 2 & -1 & 0 \\ 0 & -3 & 5 & 1 \\ 0 & -6 & 10 & 2 \end{array} \right] \xrightarrow{-2r_2+r_3} \left[\begin{array}{ccc|c} 1 & 2 & -1 & 0 \\ 0 & -3 & 5 & 1 \\ 0 & 0 & 0 & 0 \end{array} \right] \\ & \xrightarrow{-\frac{1}{3}r_2} \left[\begin{array}{ccc|c} 1 & 2 & -1 & 0 \\ 0 & 1 & -\frac{5}{3} & -\frac{1}{3} \\ 0 & 0 & 0 & 0 \end{array} \right] \xrightarrow{-2r_2+r_1} \left[\begin{array}{ccc|c} 1 & 0 & \frac{7}{3} & \frac{2}{3} \\ 0 & 1 & -\frac{5}{3} & -\frac{1}{3} \\ 0 & 0 & 0 & 0 \end{array} \right] \end{aligned}$$

Solution (continued)

Given the reduced row-echelon matrix

$$\left[\begin{array}{ccc|c} 1 & 0 & \frac{7}{3} & \frac{2}{3} \\ 0 & 1 & -\frac{5}{3} & -\frac{1}{3} \\ 0 & 0 & 0 & 0 \end{array} \right]$$

x and y are **leading variables**; z is a **non-leading variable** and so assign a **parameter** to z . Thus the solution to the original system is given by

$$\left. \begin{array}{l} x = \frac{2}{3} - \frac{7}{3}s \\ y = -\frac{1}{3} + \frac{5}{3}s \\ z = s \end{array} \right\} \text{ where } s \in \mathbb{R}.$$

Solving Systems of Linear Equations

Method II: Gaussian Elimination with Back-Substitution

- 1 Use elementary row operations to transform the augmented matrix to an equivalent **row-echelon matrix**.
- 2 The solutions (if they exist) can be determined using **back-substitution**.

Gaussian Elimination with Back Substitution

Problem

Solve the system

$$2x + y + 3z = 1$$

$$2y - z + x = 0$$

$$9z + x - 4y = 2$$

Solution

$$\left[\begin{array}{ccc|c} 2 & 1 & 3 & 1 \\ 1 & 2 & -1 & 0 \\ 1 & -4 & 9 & 2 \end{array} \right] \rightarrow \left[\begin{array}{ccc|c} 1 & 2 & -1 & 0 \\ 2 & 1 & 3 & 1 \\ 1 & -4 & 9 & 2 \end{array} \right] \rightarrow \left[\begin{array}{ccc|c} 1 & 2 & -1 & 0 \\ 0 & -3 & 5 & 1 \\ 0 & -6 & 10 & 2 \end{array} \right]$$
$$\rightarrow \left[\begin{array}{ccc|c} 1 & 2 & -1 & 0 \\ 0 & -3 & 5 & 1 \\ 0 & 0 & 0 & 0 \end{array} \right] \rightarrow \left[\begin{array}{ccc|c} 1 & 2 & -1 & 0 \\ 0 & 1 & -\frac{5}{3} & -\frac{1}{3} \\ 0 & 0 & 0 & 0 \end{array} \right]$$

Solution (continued)

This row-echelon matrix corresponds to the system

$$\begin{array}{rcl} x + 2y - z & = & 0 \\ y - \frac{5}{3}z & = & -\frac{1}{3} \end{array}, \text{ so } \begin{array}{rcl} x & = & -2y + z \\ y & = & -\frac{1}{3} + \frac{5}{3}z \end{array},$$

and thus

$$x = -2\left(-\frac{1}{3} + \frac{5}{3}z\right) + z = \frac{2}{3} - \frac{7}{3}z$$

$$y = -\frac{1}{3} + \frac{5}{3}z$$

Setting $z = s$, where $s \in \mathbb{R}$, gives us (as before):

$$x = \frac{2}{3} - \frac{7}{3}s$$

$$y = -\frac{1}{3} + \frac{5}{3}s$$

$$z = s$$

Always check your answer!

Problem

Solve the system

$$\begin{array}{rclcl} x & + & y & + & 2z & = & -1 \\ y & + & 2x & + & 3z & = & 0 \\ z & - & 2y & & & = & 2 \end{array}$$

Solution

$$\begin{aligned} & \left[\begin{array}{ccc|c} 1 & 1 & 2 & -1 \\ 2 & 1 & 3 & 0 \\ 0 & -2 & 1 & 2 \end{array} \right] \xrightarrow{-2r_1+r_2} \left[\begin{array}{ccc|c} 1 & 1 & 2 & -1 \\ 0 & -1 & -1 & 2 \\ 0 & -2 & 1 & 2 \end{array} \right] \xrightarrow{-1 \cdot r_2} \left[\begin{array}{ccc|c} 1 & 1 & 2 & -1 \\ 0 & 1 & 1 & -2 \\ 0 & -2 & 1 & 2 \end{array} \right] \\ & \xrightarrow{2r_2+r_3} \left[\begin{array}{ccc|c} 1 & 0 & 1 & 1 \\ 0 & 1 & 1 & -2 \\ 0 & 0 & 3 & -2 \end{array} \right] \xrightarrow{\frac{1}{3}r_3} \left[\begin{array}{ccc|c} 1 & 0 & 1 & 1 \\ 0 & 1 & 1 & -2 \\ 0 & 0 & 1 & -\frac{2}{3} \end{array} \right] \xrightarrow{-r_3+r_2, -r_3+r_1} \left[\begin{array}{ccc|c} 1 & 0 & 0 & \frac{5}{3} \\ 0 & 1 & 0 & -\frac{4}{3} \\ 0 & 0 & 1 & -\frac{2}{3} \end{array} \right] \end{aligned}$$

The **unique** solution is $x = \frac{5}{3}$, $y = -\frac{4}{3}$, $z = -\frac{2}{3}$.

Check your answer!

Problem

Solve the system

$$\begin{array}{rclcl} -3x_1 & - & 9x_2 & + & x_3 & = & -9 \\ 2x_1 & + & 6x_2 & - & x_3 & = & 6 \\ x_1 & + & 3x_2 & - & x_3 & = & 2 \end{array}$$

Solution

$$\left[\begin{array}{ccc|c} 1 & 3 & -1 & 2 \\ 2 & 6 & -1 & 6 \\ -3 & -9 & 1 & -9 \end{array} \right] \rightarrow \left[\begin{array}{ccc|c} 1 & 3 & -1 & 2 \\ 0 & 0 & 1 & 2 \\ 0 & 0 & -2 & -3 \end{array} \right] \rightarrow \left[\begin{array}{ccc|c} 1 & 3 & 0 & 4 \\ 0 & 0 & 1 & 2 \\ 0 & 0 & 0 & 1 \end{array} \right]$$

The last row of the final matrix corresponds to the equation

$$0x_1 + 0x_2 + 0x_3 = 1$$

which is impossible!

Therefore, this system is inconsistent, i.e., it has no solutions.

General Patterns for Systems of Linear Equations

Problem

Find all values of a , b and c (or conditions on a , b and c) so that the system

$$\begin{array}{rclcl} 2x & + & 3y & + & az & = & b \\ & & -y & + & 2z & = & c \\ x & + & 3y & - & 2z & = & 1 \end{array}$$

has (i) a unique solution, (ii) no solutions, and (iii) infinitely many solutions. In (i) and (iii), find the solution(s).

Solution

$$\left[\begin{array}{ccc|c} 2 & 3 & a & b \\ 0 & -1 & 2 & c \\ 1 & 3 & -2 & 1 \end{array} \right] \rightarrow \left[\begin{array}{ccc|c} 1 & 3 & -2 & 1 \\ 0 & -1 & 2 & c \\ 2 & 3 & a & b \end{array} \right]$$

Solution (continued)

$$\left[\begin{array}{ccc|c} 1 & 3 & -2 & 1 \\ 0 & -1 & 2 & c \\ 2 & 3 & a & b \end{array} \right] \rightarrow \left[\begin{array}{ccc|c} 1 & 3 & -2 & 1 \\ 0 & -1 & 2 & c \\ 0 & -3 & a+4 & b-2 \end{array} \right]$$

$$\rightarrow \left[\begin{array}{ccc|c} 1 & 3 & -2 & 1 \\ 0 & 1 & -2 & -c \\ 0 & -3 & a+4 & b-2 \end{array} \right] \rightarrow \left[\begin{array}{ccc|c} 1 & 0 & 4 & 1+3c \\ 0 & 1 & -2 & -c \\ 0 & 0 & a-2 & b-2-3c \end{array} \right]$$

Case 1. $a - 2 \neq 0$, i.e., $a \neq 2$. In this case,

$$\rightarrow \left[\begin{array}{ccc|c} 1 & 0 & 4 & 1+3c \\ 0 & 1 & -2 & -c \\ 0 & 0 & 1 & \frac{b-2-3c}{a-2} \end{array} \right] \rightarrow \left[\begin{array}{ccc|c} 1 & 0 & 0 & 1+3c - 4 \left(\frac{b-2-3c}{a-2} \right) \\ 0 & 1 & 0 & -c + 2 \left(\frac{b-2-3c}{a-2} \right) \\ 0 & 0 & 1 & \frac{b-2-3c}{a-2} \end{array} \right]$$

Solution (continued)

$$\left[\begin{array}{ccc|c} 1 & 0 & 0 & 1 + 3c - 4\left(\frac{b-2-3c}{a-2}\right) \\ 0 & 1 & 0 & -c + 2\left(\frac{b-2-3c}{a-2}\right) \\ 0 & 0 & 1 & \frac{b-2-3c}{a-2} \end{array} \right]$$

(i) When $a \neq 2$, the unique solution is

$$x = 1 + 3c - 4\left(\frac{b-2-3c}{a-2}\right), \quad y = -c + 2\left(\frac{b-2-3c}{a-2}\right),$$

$$z = \frac{b-2-3c}{a-2}.$$

Solution (continued)

Case 2. If $a = 2$, then the augmented matrix becomes

$$\left[\begin{array}{ccc|c} 1 & 0 & 4 & 1+3c \\ 0 & 1 & -2 & -c \\ 0 & 0 & a-2 & b-2-3c \end{array} \right] \rightarrow \left[\begin{array}{ccc|c} 1 & 0 & 4 & 1+3c \\ 0 & 1 & -2 & -c \\ 0 & 0 & 0 & b-2-3c \end{array} \right]$$

From this we see that the system has no solutions when $b - 2 - 3c \neq 0$.

(ii) When $a = 2$ and $b - 3c \neq 2$, the system has no solutions.

Solution (continued)

Finally when $a = 2$ and $b - 3c = 2$, the augmented matrix becomes

$$\left[\begin{array}{ccc|c} 1 & 0 & 4 & 1 + 3c \\ 0 & 1 & -2 & -c \\ 0 & 0 & 0 & b - 2 - 3c \end{array} \right] \rightarrow \left[\begin{array}{ccc|c} 1 & 0 & 4 & 1 + 3c \\ 0 & 1 & -2 & -c \\ 0 & 0 & 0 & 0 \end{array} \right]$$

and the system has infinitely many solutions.

(iii) When $a = 2$ and $b - 3c = 2$, the system has infinitely many solutions, given by

$$\begin{aligned} x &= 1 + 3c - 4s \\ y &= -c + 2s \\ z &= s \end{aligned}$$

where $s \in \mathbb{R}$.

Uniqueness of the Reduced Row-Echelon Form

Theorem

Systems of linear equations that correspond to row equivalent augmented matrices have exactly the same solutions.

Theorem

Every matrix A is row equivalent to a **unique** reduced row-echelon matrix.

Homogeneous Systems of Equations

Definition

A **homogeneous linear equation** is one whose constant term is equal to zero. A system of linear equations is called **homogeneous** if each equation in the system is homogeneous. A **homogeneous system** has the form

$$a_{11}x_1 + a_{12}x_2 + \cdots + a_{1n}x_n = 0$$

$$a_{21}x_1 + a_{22}x_2 + \cdots + a_{2n}x_n = 0$$

$$\vdots$$

$$a_{m1}x_1 + a_{m2}x_2 + \cdots + a_{mn}x_n = 0$$

where a_{ij} are scalars and x_i are variables, $1 \leq i \leq m$, $1 \leq j \leq n$.

Notice that $x_1 = 0, x_2 = 0, \dots, x_n = 0$ is always a solution to a homogeneous system of equations. We call this the **trivial solution**.

We are interested in finding, if possible, **nontrivial solutions** (ones with at least one variable not equal to zero) to homogeneous systems.

Homogeneous Equations

Example

Solve the system

$$\begin{array}{rccccrcr} x_1 & + & x_2 & - & x_3 & + & 3x_4 & = & 0 \\ -x_1 & + & 4x_2 & + & 5x_3 & - & 2x_4 & = & 0 \\ x_1 & + & 6x_2 & + & 3x_3 & + & 4x_4 & = & 0 \end{array}$$

$$\left[\begin{array}{cccc|c} 1 & 1 & -1 & 3 & 0 \\ -1 & 4 & 5 & -2 & 0 \\ 1 & 6 & 3 & 4 & 0 \end{array} \right] \rightarrow \dots \rightarrow \left[\begin{array}{cccc|c} 1 & 0 & -\frac{9}{5} & \frac{14}{5} & 0 \\ 0 & 1 & \frac{4}{5} & \frac{1}{5} & 0 \\ 0 & 0 & 0 & 0 & 0 \end{array} \right]$$

The system has infinitely many solutions, and the general solution is

$$\begin{array}{l} x_1 = \frac{9}{5}s - \frac{14}{5}t \\ x_2 = -\frac{4}{5}s - \frac{1}{5}t \\ x_3 = s \\ x_4 = t \end{array} \quad \text{or} \quad \begin{bmatrix} x_1 \\ x_2 \\ x_3 \\ x_4 \end{bmatrix} = \begin{bmatrix} \frac{9}{5}s - \frac{14}{5}t \\ -\frac{4}{5}s - \frac{1}{5}t \\ s \\ t \end{bmatrix}, \text{ where } s, t \in \mathbb{R}.$$

Definition

If X_1, X_2, \dots, X_p are columns with the same number of entries, and if $a_1, a_2, \dots, a_p \in \mathbb{R}$ (are scalars) then $a_1X_1 + a_2X_2 + \dots + a_pX_p$ is a **linear combination** of columns X_1, X_2, \dots, X_p .

Example (continued)

In the previous example,

$$\begin{aligned} \begin{bmatrix} x_1 \\ x_2 \\ x_3 \\ x_4 \end{bmatrix} &= \begin{bmatrix} \frac{9}{5}s - \frac{14}{5}t \\ -\frac{4}{5}s - \frac{1}{5}t \\ s \\ t \end{bmatrix} = \begin{bmatrix} \frac{9}{5}s \\ -\frac{4}{5}s \\ s \\ 0 \end{bmatrix} + \begin{bmatrix} -\frac{14}{5}t \\ -\frac{1}{5}t \\ 0 \\ t \end{bmatrix} \\ &= s \begin{bmatrix} \frac{9}{5} \\ -\frac{4}{5} \\ 1 \\ 0 \end{bmatrix} + t \begin{bmatrix} -\frac{14}{5} \\ -\frac{1}{5} \\ 0 \\ 1 \end{bmatrix} \end{aligned}$$

Example (continued)

This gives us

$$\begin{bmatrix} x_1 \\ x_2 \\ x_3 \\ x_4 \end{bmatrix} = s \begin{bmatrix} \frac{9}{5} \\ -\frac{4}{5} \\ 1 \\ 0 \end{bmatrix} + t \begin{bmatrix} -\frac{14}{5} \\ -\frac{1}{5} \\ 0 \\ 1 \end{bmatrix} = sX_1 + tX_2,$$

$$\text{where } X_1 = \begin{bmatrix} \frac{9}{5} \\ -\frac{4}{5} \\ 1 \\ 0 \end{bmatrix} \text{ and } X_2 = \begin{bmatrix} -\frac{14}{5} \\ -\frac{1}{5} \\ 0 \\ 1 \end{bmatrix}.$$

The columns X_1 and X_2 are called **basic solutions** to the original homogeneous system.

Example (continued)

Notice that

$$\begin{aligned} \begin{bmatrix} x_1 \\ x_2 \\ x_3 \\ x_4 \end{bmatrix} &= s \begin{bmatrix} \frac{9}{5} \\ -\frac{4}{5} \\ 1 \\ 0 \end{bmatrix} + t \begin{bmatrix} -\frac{14}{5} \\ -\frac{1}{5} \\ 0 \\ 1 \end{bmatrix} = \frac{s}{5} \begin{bmatrix} 9 \\ -4 \\ 5 \\ 0 \end{bmatrix} + \frac{t}{5} \begin{bmatrix} -14 \\ -1 \\ 0 \\ 5 \end{bmatrix} \\ &= r \begin{bmatrix} 9 \\ -4 \\ 5 \\ 0 \end{bmatrix} + q \begin{bmatrix} -14 \\ -1 \\ 0 \\ 5 \end{bmatrix} \\ &= r(5X_1) + q(5X_2) \end{aligned}$$

where $r, q \in \mathbb{R}$.

Example (continued)

The columns $5X_1 = \begin{bmatrix} 9 \\ -4 \\ 5 \\ 0 \end{bmatrix}$ and $5X_2 = \begin{bmatrix} -14 \\ -1 \\ 0 \\ 5 \end{bmatrix}$ are also basic solutions to the original homogeneous system.

In general, any nonzero multiple of a basic solution (to a homogeneous system of linear equations) is also a basic solution.

Theorem

The general solution to a homogeneous system can be expressed as a **linear combination** of **basic solutions**.

Proof.

Consider the RREF matrix equivalent to the augmented matrix of the system.

Each non-leading variable corresponds to a parameter; let N be the set of non-leading variables and enumerate the parameters as s_j , for $j \in N$. Then, for scalars c_{ij} , the general solution has the form

$$x_i = \sum_{j \in N} c_{ij} s_j \quad (1)$$

i.e. each variable—leading or not—is expressed as a linear combination of the parameters. Because the system is homogeneous, on the RHS we have a linear combination of s_j s **with no constant terms**.

Proof. (continued).

Re-arranging, we obtain general solution of the form

$$\begin{bmatrix} x_1 \\ x_2 \\ \vdots \\ x_n \end{bmatrix} = \sum_{j \in N} s_j \begin{bmatrix} c_{1j} \\ c_{2j} \\ \vdots \\ c_{nj} \end{bmatrix}$$

(each row corresponds to an instance of (1), with the 1st row corresponding to x_1 , the second row corresponding to x_2 , etc.) which is a linear combination of the basic solutions.

This completes the proof. □

Problem

Find all values of a for which the system

$$\begin{aligned}x + y &= 0 \\ ay + z &= 0 \\ x + y + az &= 0\end{aligned}$$

has nontrivial solutions, and determine the solutions.

Solution

Non-trivial solutions occur only when $a = 0$, and the solutions when $a = 0$ are given by

$$\begin{bmatrix} x \\ y \\ z \end{bmatrix} = s \begin{bmatrix} 1 \\ -1 \\ 0 \end{bmatrix}, \quad s \in \mathbb{R}.$$

Rank

Definition

The **rank** of a matrix A , denoted $\text{rank } A$, is the number of leading 1's in any row-echelon matrix obtained from A by performing elementary row operations.

What does the rank of an augmented matrix tell us?

Suppose A is the augmented matrix of a **consistent** system of m linear equations in n variables, and $\text{rank } A = r$.

$$m \left\{ \left[\begin{array}{cccc|c} * & * & * & * & * \\ * & * & * & * & * \\ * & * & * & * & * \\ * & * & * & * & * \\ * & * & * & * & * \end{array} \right] \rightarrow \left[\begin{array}{cccc|c} 1 & * & * & * & * \\ 0 & 0 & 1 & * & * \\ 0 & 0 & 0 & 1 & * \\ 0 & 0 & 0 & 0 & 0 \\ 0 & 0 & 0 & 0 & 0 \end{array} \right] \right.$$

$\underbrace{\hspace{10em}}_n \qquad \qquad \qquad \underbrace{\hspace{10em}}_{r \text{ leading } 1\text{'s}}$

Then the set of solutions to the system has $n - r$ parameters, so

- if $r < n$, there is at least one parameter, and the system has infinitely many solutions;
- if $r = n$, there are no parameters, and the system has a unique solution.

An Example

Problem

Find the rank of $A = \begin{bmatrix} a & b & 5 \\ 1 & -2 & 1 \end{bmatrix}$.

Solution

$$\begin{bmatrix} a & b & 5 \\ 1 & -2 & 1 \end{bmatrix} \rightarrow \begin{bmatrix} 1 & -2 & 1 \\ a & b & 5 \end{bmatrix} \rightarrow \begin{bmatrix} 1 & -2 & 1 \\ 0 & b+2a & 5-a \end{bmatrix}$$

If $b + 2a = 0$ and $5 - a = 0$, i.e., $a = 5$ and $b = -10$, then $\text{rank } A = 1$.
Otherwise, $\text{rank } A = 2$.

Solutions to a System of Linear Equations

For **any** system of linear equations, exactly one of the following holds:

- 1 the system is **inconsistent**;
- 2 the system has a **unique** solution, i.e., exactly one solution;
- 3 the system has **infinitely many** solutions.

One can see what case applies by looking at the RREF matrix equivalent to the augmented matrix of the system and distinguishing three cases:

- 1 The last nonzero row ends with $\dots 0 \ 1$]: no solution.
- 2 The last nonzero row does not end with $\dots 0 \ 1$] and all variables are leading: unique solution.
- 3 The last nonzero row does not end with $\dots 0 \ 1$] and there are non-leading variables: infinitely many solutions.

Problem

Solve the system

$$\begin{array}{r} -3x_1 + 6x_2 - 4x_3 - 9x_4 + 3x_5 = -1 \\ -x_1 + 2x_2 - 2x_3 - 4x_4 - 3x_5 = 3 \\ x_1 - 2x_2 + 2x_3 + 2x_4 - 5x_5 = 1 \\ x_1 - 2x_2 + x_3 + 3x_4 - x_5 = 1 \end{array}$$

Solution

Begin by putting the augmented matrix in reduced row-echelon form.

$$\left[\begin{array}{ccccc|c} 1 & -2 & 2 & 2 & -5 & 1 \\ -3 & 6 & -4 & -9 & 3 & -1 \\ -1 & 2 & -2 & -4 & -3 & 3 \\ 1 & -2 & 1 & 3 & -1 & 1 \end{array} \right] \rightarrow \left[\begin{array}{ccccc|c} 1 & -2 & 0 & 0 & -13 & 9 \\ 0 & 0 & 1 & 0 & 0 & -2 \\ 0 & 0 & 0 & 1 & 4 & -2 \\ 0 & 0 & 0 & 0 & 0 & 0 \end{array} \right]$$

The system has 5 variables, and the rank of the augmented matrix is 3. Since the system is consistent, the set of solutions has $5 - 3 = 2$ parameters.

Solution (continued)

From the reduced row-echelon matrix

$$\left[\begin{array}{ccccc|c} 1 & -2 & 0 & 0 & -13 & 9 \\ 0 & 0 & 1 & 0 & 0 & -2 \\ 0 & 0 & 0 & 1 & 4 & -2 \\ 0 & 0 & 0 & 0 & 0 & 0 \end{array} \right]$$

we obtain the general solution

$$\left. \begin{array}{l} x_1 = 9 + 2r + 13s \\ x_2 = r \\ x_3 = -2 \\ x_4 = -2 - 4s \\ x_5 = s \end{array} \right\} r, s \in \mathbb{R}$$

The solution has two parameters (r and s) as we expected.

Review Problem

Problem

The following is the reduced row-echelon form of the augmented matrix of a system of linear equations.

$$\left[\begin{array}{ccccc|c} 1 & 0 & -3 & 0 & 6 & 8 \\ 0 & 1 & 1 & 0 & 2 & 0 \\ 0 & 0 & 0 & 1 & 5 & -5 \\ 0 & 0 & 0 & 0 & 0 & 0 \\ 0 & 0 & 0 & 0 & 0 & 0 \end{array} \right]$$

- How many equations does the system have? 5
- How many variables does the system have? 5
- If the variables are labeled x_1, x_2, x_3, x_4, x_5 , which variables are the
 - leading variables? x_1, x_2, x_4
 - non-leading variables? x_3, x_5

Problem (continued)

$$\left[\begin{array}{ccccc|c} 1 & 0 & -3 & 0 & 6 & 8 \\ 0 & 1 & 1 & 0 & 2 & 0 \\ 0 & 0 & 0 & 1 & 5 & -5 \\ 0 & 0 & 0 & 0 & 0 & 0 \\ 0 & 0 & 0 & 0 & 0 & 0 \end{array} \right]$$

- What is the rank of this matrix? **3**
- How many parameters (if any) do we need for the general solution? **2**
- What is the system of equations corresponding to this matrix?

$$\begin{array}{rclcl} x_1 & & - 3x_3 & & + 6x_5 & = 8 \\ & x_2 & + x_3 & & + 2x_5 & = 0 \\ & & & x_4 & + 5x_5 & = -5 \end{array}$$

- Is this system homogeneous or inhomogeneous? **Inhomogeneous**

Problem (continued)

$$\begin{array}{rclcrcl} x_1 & & -3x_3 & & +6x_5 & = & 8 \\ & x_2 & & +x_3 & & +2x_5 & = & 0 \\ & & & & x_4 & +5x_5 & = & -5 \end{array}$$

- What is the general solution? Assign parameters $s, t \in \mathbb{R}$ to the non-leading variables x_3 and x_5 , respectively.

$$x_1 = 8 + 3s - 6t$$

$$x_2 = -s - 2t$$

$$x_3 = s$$

$$x_4 = -5 - 5t$$

$$x_5 = t$$

The general solution may also be written as

$$\begin{bmatrix} x_1 \\ x_2 \\ x_3 \\ x_4 \\ x_5 \end{bmatrix} = \begin{bmatrix} 8 \\ 0 \\ 0 \\ -5 \\ 0 \end{bmatrix} + s \begin{bmatrix} 3 \\ -1 \\ 1 \\ 0 \\ 0 \end{bmatrix} + t \begin{bmatrix} -6 \\ -2 \\ 0 \\ -5 \\ 1 \end{bmatrix}, \text{ for } s, t \in \mathbb{R}.$$

Balancing Chemical Reactions

Problem

Balance the chemical reaction given below involving tin (Sn), hydrogen (H), and oxygen (O).

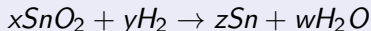

Solution

Setting up a system of equations in x, y, z, w gives

$$Sn : x = z \text{ or } x - z = 0$$

$$O : 2x = w \text{ or } 2x - w = 0$$

$$H : 2y = 2w \text{ or } 2y - 2w = 0$$

The augmented matrix is
$$\left[\begin{array}{cccc|c} 1 & 0 & -1 & 0 & 0 \\ 2 & 0 & 0 & -1 & 0 \\ 0 & 2 & 0 & -2 & 0 \end{array} \right]$$

Solution (continued)

The reduced row-echelon matrix is

$$\left[\begin{array}{cccc|c} 1 & 0 & 0 & -\frac{1}{2} & 0 \\ 0 & 1 & 0 & -1 & 0 \\ 0 & 0 & 1 & -\frac{1}{2} & 0 \end{array} \right]$$

Letting $w = t$, the solution is

$$\begin{aligned} x &= \frac{1}{2}t \\ y &= t \\ z &= \frac{1}{2}t \\ w &= t \end{aligned}$$

We can choose any values for $w = t$. Suppose we choose $w = 4$, then $x = 2, y = 4, z = 2$ and the balanced reaction is

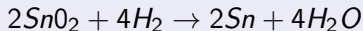

Resistor Networks

Important Symbols:

Resistor: 

Voltage Source: 

Current:



Resistance is measured in *ohms*, Ω . Voltage is measured in *volts*, V .
Current is measured in *amps*, A .

Problem

Write an equation for each circuit and solve for each current in the following diagram.

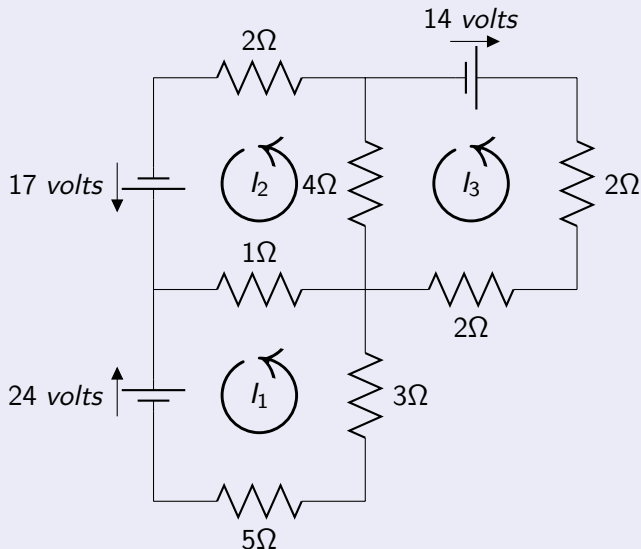

Solution

The equation for the bottom circuit, with current I_1 is given by

$$5I_1 + 3I_1 + I_1 - I_2 = -24$$

The top left circuit, with current I_2 is

$$I_2 - I_1 + 4I_2 - 4I_3 + 2I_2 = 17$$

The top right circuit is

$$4I_3 - 4I_2 + 2I_3 + 2I_3 = -14$$

After simplifying, this system is represented by

$$\left[\begin{array}{ccc|c} 9 & -1 & 0 & -24 \\ -1 & 7 & -4 & 17 \\ 0 & -4 & 8 & -14 \end{array} \right]$$

Solution (continued)

The reduced row-echelon form of this matrix is

$$\left[\begin{array}{ccc|c} 1 & 0 & 0 & -\frac{5}{2} \\ 0 & 1 & 0 & \frac{3}{2} \\ 0 & 0 & 1 & -1 \end{array} \right]$$

This gives values of the currents of

$$I_1 = -\frac{5}{2}$$

$$I_2 = \frac{3}{2}$$

$$I_3 = -1$$