

LEVEL ONE – KNOWLEDGE

8 questions, 1 mark each

1. A careful study of DNA sequences reveals that a population of mussels in a particular river has very little genetic variation in it. Which of the following hypotheses would you REJECT as an explanation for this observation?

- A) There has been intense natural selection favouring individuals with a particular trait. ✓
- B) There has been a great deal of movement of mussels into this river from nearby lakes. ✗
- C) A severe storm once left only a few survivors in this population. ✓
- D) This species of mussel has remarkably efficient DNA repair enzymes. ✓
- E) This population was established by only a few larvae that were carried into the river by a fish host. ✓

2. Which of the following is an example of phenotypic plasticity?

- A) Some species of mussels attach to rocks as juveniles whereas others do not. ✗
- B) Only female mussels have lures that resemble the prey of their fish hosts. ✗
- C) Mussels reared in the lab may be less bumpy than ones raised in a flowing river. ✓
- D) Mussels use their siphons for feeding as well as reproduction. ✗
- E) Mussels produce an equal number of male and female offspring each year. ✗

3. Which of the following statements is TRUE about the mussels of the Great Lakes region?

- A) Zebra mussels are invasive, having arrived from Europe approximately 200 years ago. ✗
- B) The native mussels in Ontario have been present in exactly the same lakes for more than 100,000 years.
- C) Female native mussels have modifications of the mantle for use in caring for their embryos.
- D) The native mussels in Ontario are all members of the family Dreissenidae. ✗
- E) All of the native mussel species in this region have a parasitic larval stage. ✓

4. Which of the following observations is most likely to be associated with population bottlenecks?

- A) A single river is found to be home to 20 or more species of mussels of different sizes. ✗
- B) Fish hosts carry the larvae of native mussels from one part of a river to another. ✗
- C) Some native mussels were overfished to the point of near extirpation for use in making buttons prior to the invention of plastics. ✓
- D) A few zebra mussels attach to a boat and are transported to a lake that previously did not have zebra mussels. ✗
- E) Mussel species with very complex lures tend to attract only one species of fish host. ✗

The phylogeny below shows the evolutionary relationships between species A through I.

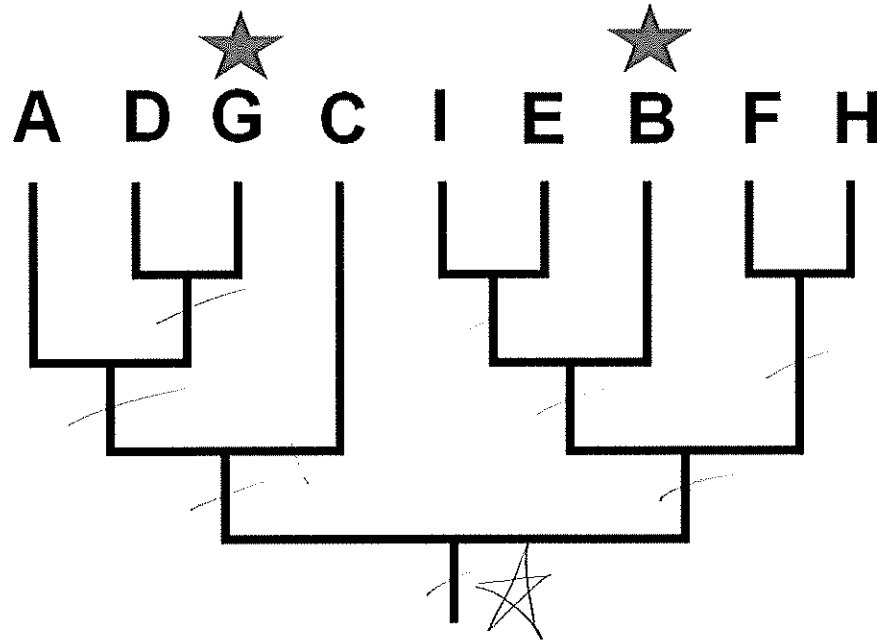

5. How many clades are shown in this tree?

- A) 5 clades
- B) 6 clades
- C) 7 clades
- D) 8 clades
- E) 9 clades

6. Species G and B have a particular trait ("starriness") that is not found in the other species. If you hypothesize that the trait is homologous between species G and B (i.e., it is not an example of convergent evolution), then what is the minimum number of times that you must assume that this trait has been lost?

- A) Starriness was lost at least 5 times.
- B) Starriness was lost at least 6 times.
- C) Starriness was lost at least 7 times.
- D) Starriness was lost at least 8 times.
- E) Starriness was lost at least 9 times.

7. Which of the following statements is FALSE?

- A) The formation of new species can occur only when there are mechanisms to increase the amount of gene flow.
- B) Cladistics seeks to give formal names only to monophyletic groups.
- C) Compared to beetles, mammals are not very diverse but are very disparate.
- D) Diversity refers to the number of species in a given area or taxonomic group.
- E) Mass extinctions typically involve the loss of more than 50% of species in a few hundred thousand years or less.

8. Consider the following about mussels in a particular region:

- (i) On occasion, mussels may move into a new river where members of that species were not found previously. *founder*
- (ii) On occasion, individuals from river populations can be washed into lakes where they breed with members of an existing lake population. *gene flow*
- (iii) A storm washes pesticides from a farm field into a river, and suddenly kills a large portion of the mussels living there. *genetic drift (pop bottle)*
- (iv) Some mussel species have very complex lures that attract a specific fish host. *special*
- (v) Some mussel species can be found in a few rivers, but not in all of the rivers where they formerly were found. *extir*

Which of the following pairs of terms best describes observations (i) and (iv)?

- A) Founder effects and specialization.
- B) Founder effects and population bottlenecks.
- C) Invasion and extinction.
- D) Mutation and adaptation.
- E) Gene flow and extirpation.

LEVEL TWO – COMPREHENSION

4 questions, 1 mark each

9. Which two of the trees shown below have the same topology (i.e., branching order, or relationships among lineages), if any? A B C D

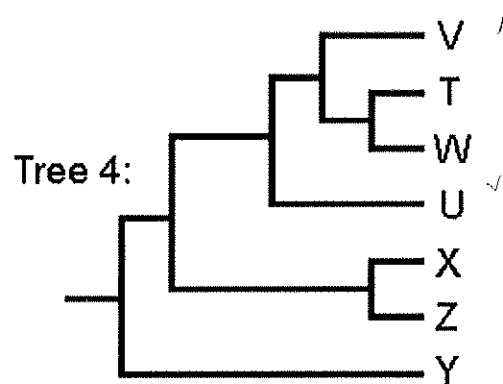
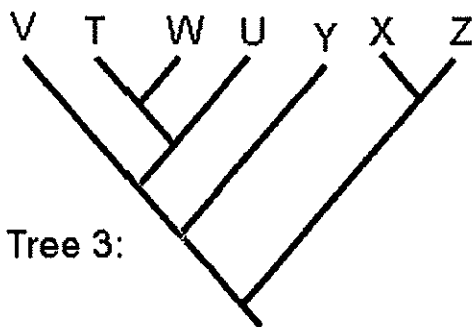
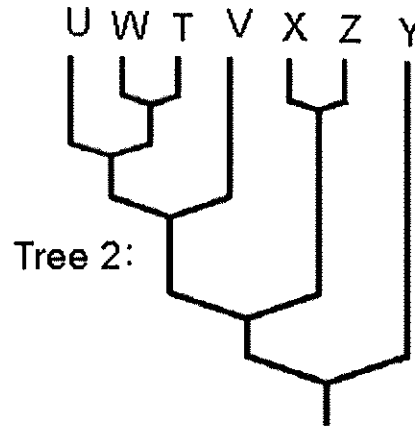
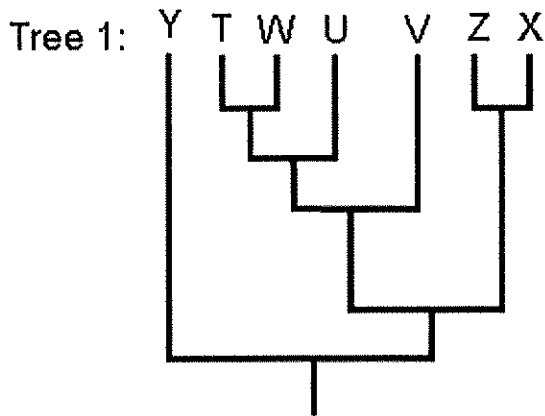

- A) Tree 1 and Tree 2 have the same topology.
- B) Tree 2 and Tree 3 have the same topology.
- C) Tree 3 and Tree 4 have the same topology.
- D) All four trees have the same topology.
- E) Each of the four trees has a different topology.

The following phylogenetic tree shows the relationships among freshwater mussel groups. The suffix *-idae* indicates a family, *-inae* indicates a subfamily, and *-ini* indicates a tribe. Note that this tree contains many “polytomies”, or nodes that are not fully resolved.

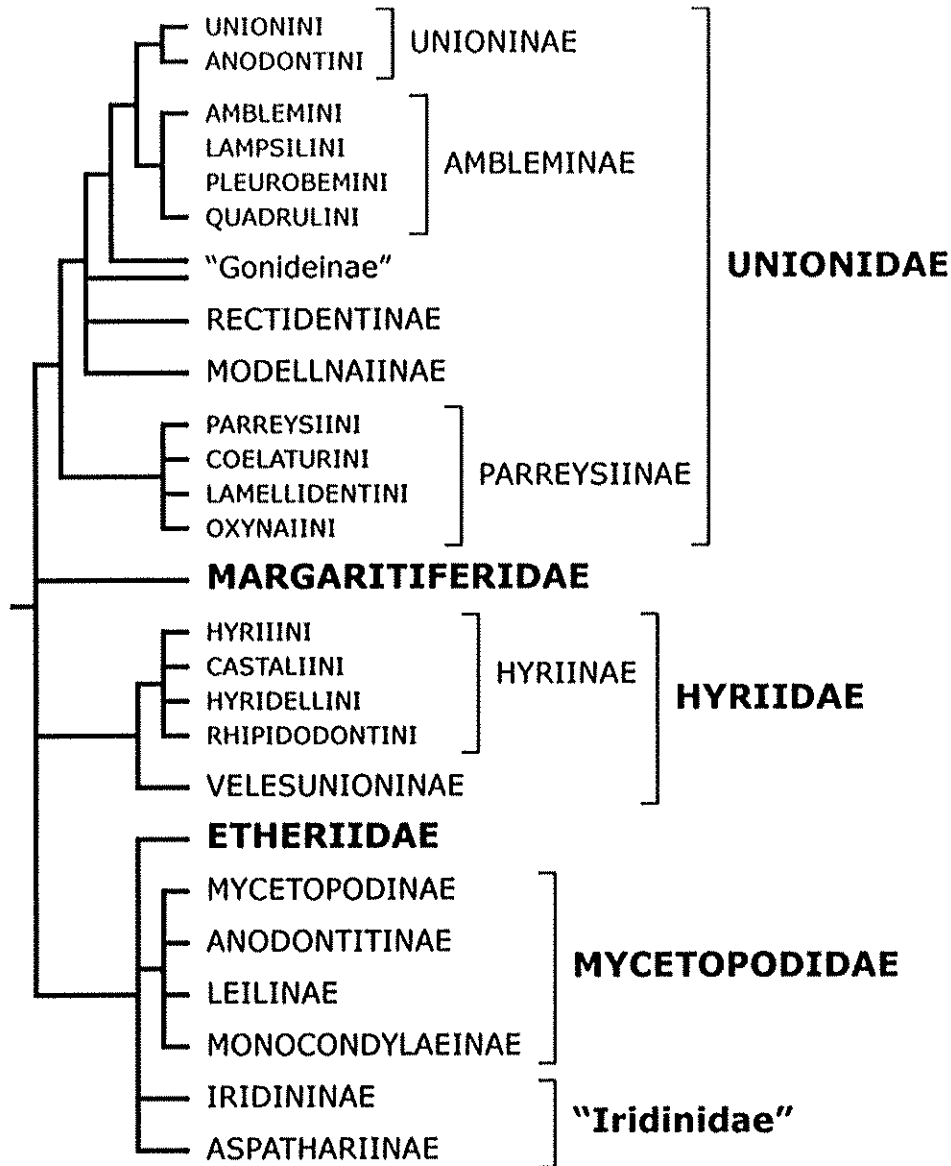

10. Which of the following statements is FALSE about this phylogenetic tree?

- A) The lineage now represented by the family Unionidae and the one now represented by the family Hyriidae have been evolving for the same amount of time. ✓
- B) The subfamilies Unioninae and Ambleminae are sister taxa. ✓
- C) The family Unionidae is monophyletic, but the family Hyriidae is not. ✓
- D) The family Etheriidae is more closely related to the family Mycetopodidae than it is to the family Hyriidae. ✓
- E) The group classified as the family "Iridinidae" is problematic because it is not monophyletic.

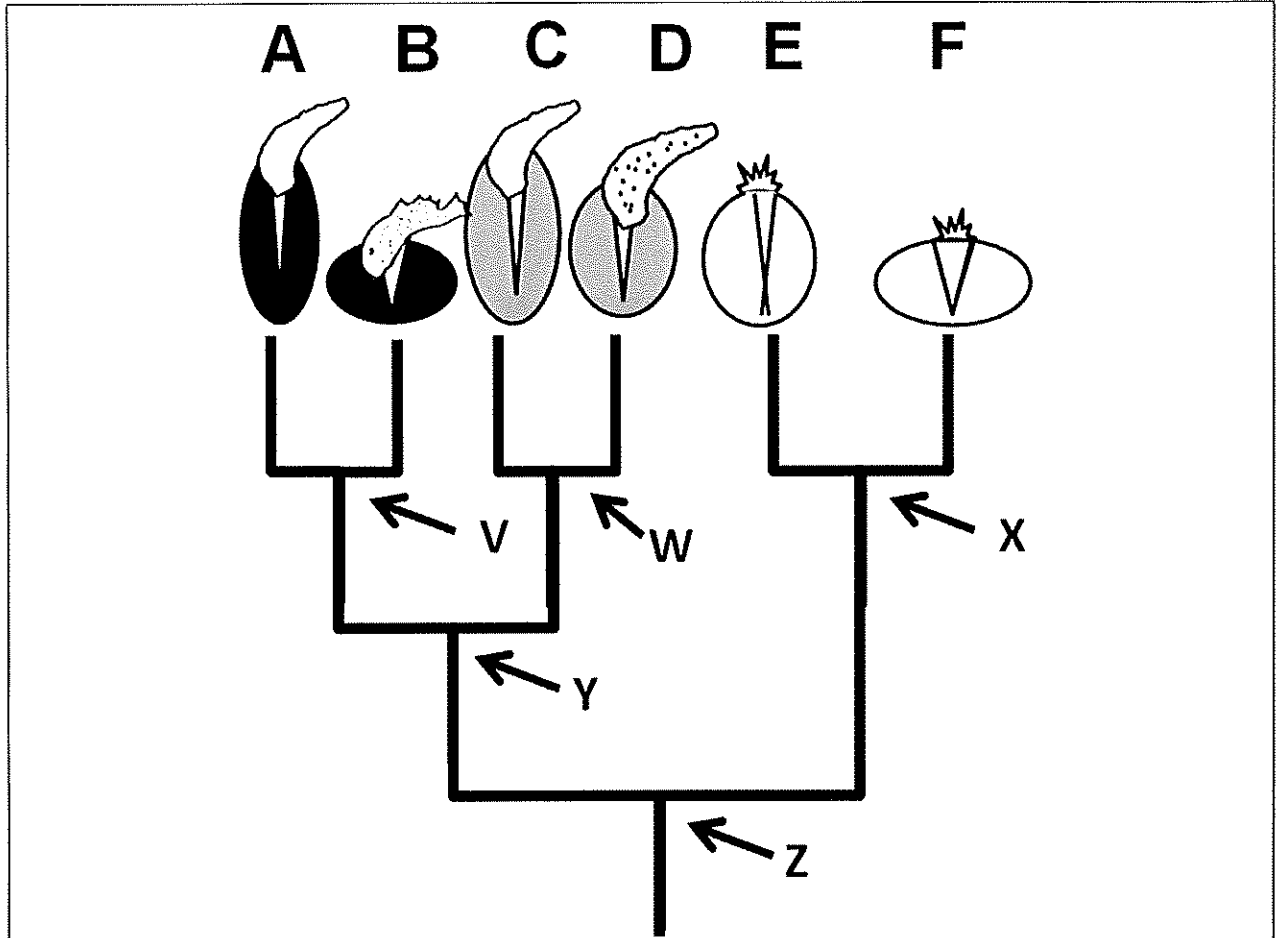

11. Which interpretation of the tree above is CORRECT?

- A) A group called “white-shelled mussels” would be paraphyletic.
- B) The evolution of shell shape in this group is an example of homology.
- C) Shell colour seems to change more easily than shell shape over evolutionary time.
- D) It is possible that shell colour changed only twice during the evolution of this group.
- E) Either large lures evolved at least twice or they were lost at least twice in this group.

12. Which interpretation of the tree above is best supported by the available information?

- A) Ancestor V probably had a partially flattened shell shape.
- B) Ancestor W probably had a grey shell.
- C) Ancestor X probably had a complex lure that was then lost.
- D) Ancestor Y probably had a black shell.
- E) Ancestor Z probably had a white shell.

LEVEL THREE – APPLICATION

3 questions, 1 mark each

This tree is taken from a real scientific paper (Bogan and Roe 2008) that used phylogenetic methods to investigate the evolution of fish host use by unionid mussels. The species at the terminal nodes are mussels. The legend indicates which fish family is used as host.

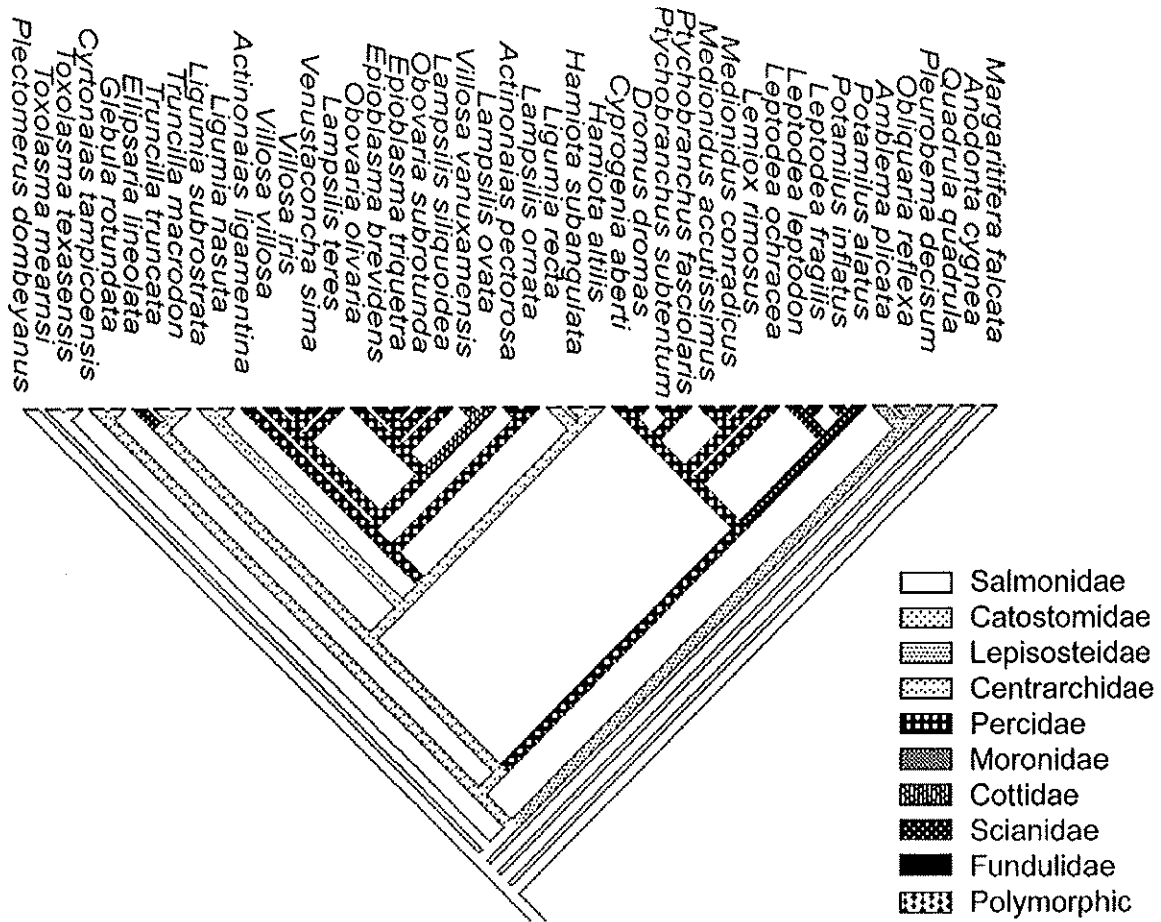

13. Based on the tree presented above, which of the following statements is TRUE about the evolution of fish host use in these mussels?

- A) We cannot draw any reasonable conclusions regarding what type of fish host was used by the common ancestor of all these mussels. ✗
- B) This phylogeny suggests that lineages of mussels never switch fish hosts. ✗
- C) The use of fishes in the family Percidae as hosts is probably an example of homoplasy among the mussel species that share this trait. ✓
- D) The mussel species that use fishes in the family Salmonidae probably switched to them from other hosts. ✗
- E) Information about fish host use alone would be useful for sorting out evolutionary relationships among these mussel species. ✗

The recent construction of a new road through a forested area has created a barrier between two populations of *Utensilus plasticus*. As you know, there are different morphs in this species, including a spoon morph and a fork morph. You decide to observe the two populations for several generations, and you notice the following:

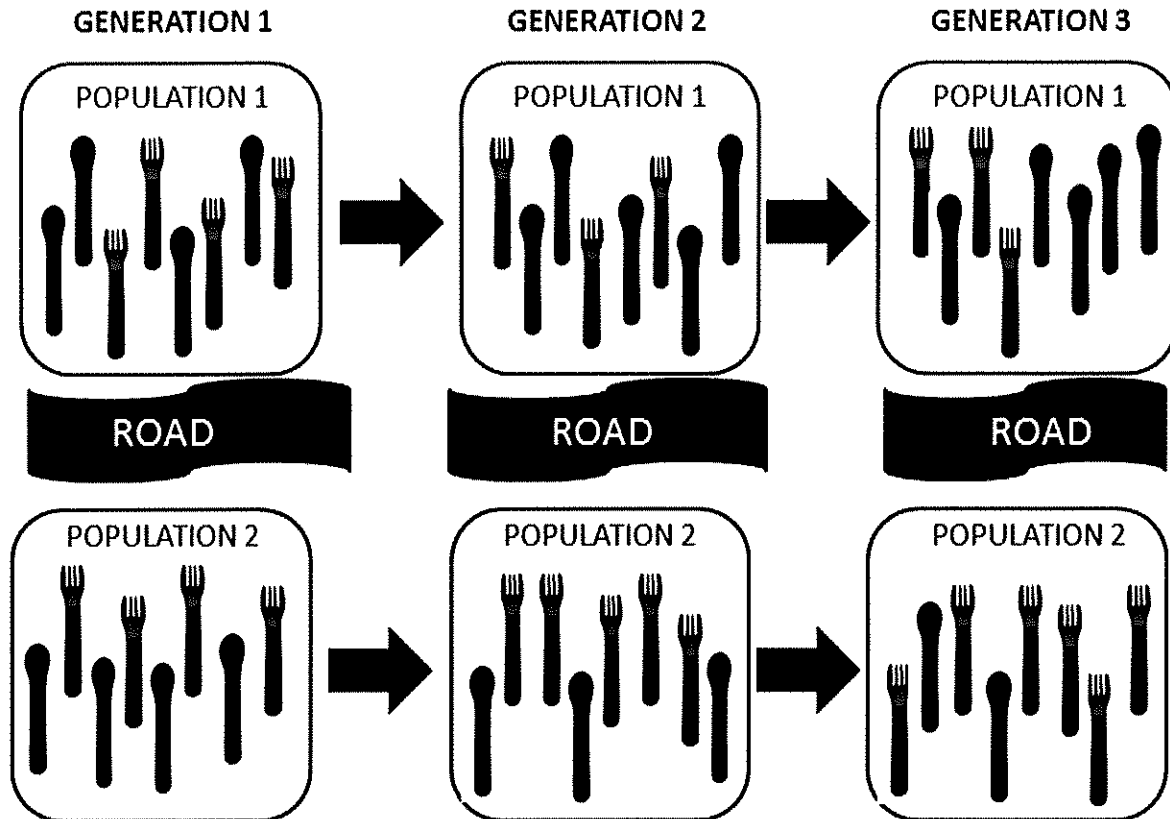

14. Which of the following statements is **PLAUSIBLE** based on your observations?

- A) It is likely that spoons will eventually become the only morph remaining in this species.^x
- B) Living conditions in the area where Population 2 is found are much harsher than where Population 1 is found.^x
- C) Founder effects probably account for the differences in the proportion of forks and spoons in the two populations observed in Generation 3.^x
- D) There may be differences in the types of prey that are available on either side of the road.[✓]
- E) There is extensive gene flow between these two populations, which maintains both morphs in the two populations.^x

15. Which one of the following statements is FALSE with regard to mussels that have glochidia larvae versus mussels that have veliger larvae?

A) Species with veliger larvae are more resistant to extinction because they tend to spread across a wider geographic range. ✓

B) Species with veliger larvae are less likely to speciate because their ability to disperse increases gene flow among populations. ✓

C) Species with glochidia larvae that are highly specialized for attracting a single fish host are more likely to go extinct than species with veliger larvae. ✓

D) Species with glochidia larvae are less likely to speciate because the limited dispersal of their larvae means less gene flow will occur among populations. ✗

E) Species with veliger larvae are more likely to become invasive species than species with glochidia larvae.

