

CVG 4148  
Theory of Structures II

**FINAL EXAMINATION**

**Length of Examination: 3 hours**

**December 9<sup>th</sup>, 2011, 9:30**

Professor: Dr. B. Martín-Pérez

Page 1 of 3

Family Name: \_\_\_\_\_

Other Names: \_\_\_\_\_

Student Number: \_\_\_\_\_

Number of booklets submitted: \_\_\_\_\_

Signature: \_\_\_\_\_

**OPEN BOOK EXAM.**

- If you do not understand a question, clearly state an assumption and proceed.
- Programmable calculators or other electronic devices are not allowed.
- Questions can be done in any order.
- You are required to provide all details of your calculations.
- Clearly label your answers and provide units, if applicable.

At the end of the exam, when time is up:

- Stop working and turn your exam upside down.
- Remain silent.
- Do not move or speak until all exams have been picked up, and a TA or the Professor gives the go-ahead to leave.

1. (20 marks)

Assemble the structure stiffness matrix  $[K]$  for the T-Bar truss shown in Fig. 1. The two rods act in tension and stiffen the system. The post is rigidly connected to the beam. Note that  $E = 200$  GPa for steel and  $E = 7$  GPa for timber.

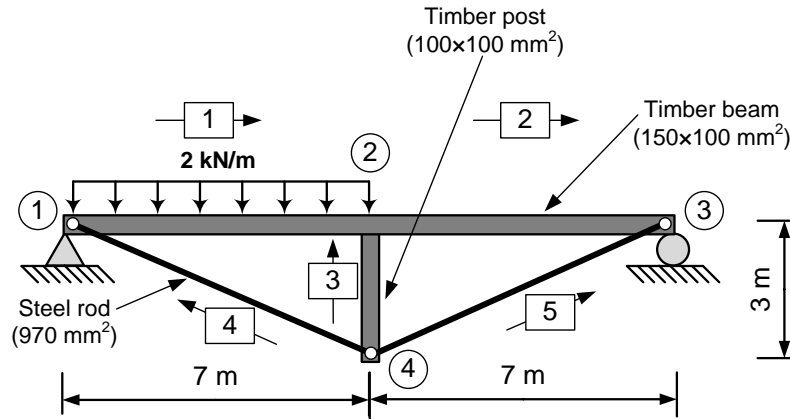

Fig. 1

The stiffness matrices in the global coordinate system for members 4 and 5 are given below in kN/m.

$$[k_g]^{(4)} = \begin{bmatrix} 21,485 & -9,208 & 0 & -21,485 & 9,208 & 0 \\ -9,208 & 3,946 & 0 & 9,208 & -3,946 & 0 \\ 0 & 0 & 0 & 0 & 0 & 0 \\ -21,485 & 9,208 & 0 & 21,485 & -9,208 & 0 \\ 9,208 & -3,946 & 0 & -9,208 & 3,946 & 0 \\ 0 & 0 & 0 & 0 & 0 & 0 \end{bmatrix} \quad [k_g]^{(5)} = \begin{bmatrix} 21,485 & 9,208 & 0 & -21,485 & -9,208 & 0 \\ 9,208 & 3,946 & 0 & -9,208 & -3,946 & 0 \\ 0 & 0 & 0 & 0 & 0 & 0 \\ -21,485 & -9,208 & 0 & 21,485 & 9,208 & 0 \\ -9,208 & -3,946 & 0 & 9,208 & 3,946 & 0 \\ 0 & 0 & 0 & 0 & 0 & 0 \end{bmatrix}$$

2. (20 marks)

If the global end displacements for members 1 and 5 in Fig. 1 are given by  $\{v\}^{(1)}$  and  $\{v\}^{(5)}$ , respectively, calculate the member end forces for those members. Are these two members in equilibrium under these forces?

$$\{v\}^{(1)} = \begin{Bmatrix} 0 \\ 0 \\ -0.00938 \text{ rad} \\ -4.43 \text{ mm} \\ -19.75 \text{ mm} \\ 0.004927 \text{ rad} \end{Bmatrix}, \quad \{v\}^{(5)} = \begin{Bmatrix} -4.04 \text{ mm} \\ -17.73 \text{ mm} \\ -0.00246 \text{ rad} \\ -8.40 \text{ mm} \\ 0 \\ -0.0023 \text{ rad} \end{Bmatrix}$$

3. (20 marks)

Determine the joint displacements, member end forces, and support reactions for the beam shown in Fig. 3 due to a linearly varying temperature increase of  $55^{\circ}\text{C}$  at the top surface of the beam and  $5^{\circ}\text{C}$  at the bottom surface of the beam. Note that  $EI = \text{constant}$ ,  $E = 200 \text{ GPa}$ ,  $I = 145 \times 10^6 \text{ mm}^4$ ,  $\alpha = 1.2 \times 10^{-5}/^{\circ}\text{C}$  and  $d = 300 \text{ mm}$ .

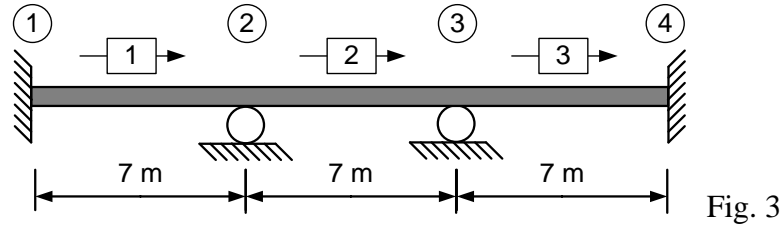

4. (20 marks)

Vector  $\{d\}$  provides the joint displacements for the frame shown in Fig. 4 under the given load. Determine the member end forces and reactions of the frame.  $E = 200 \text{ GPa}$ ,  $A = 13,000 \text{ mm}^2$ ,  $I = 762 \times 10^6 \text{ mm}^4$ .

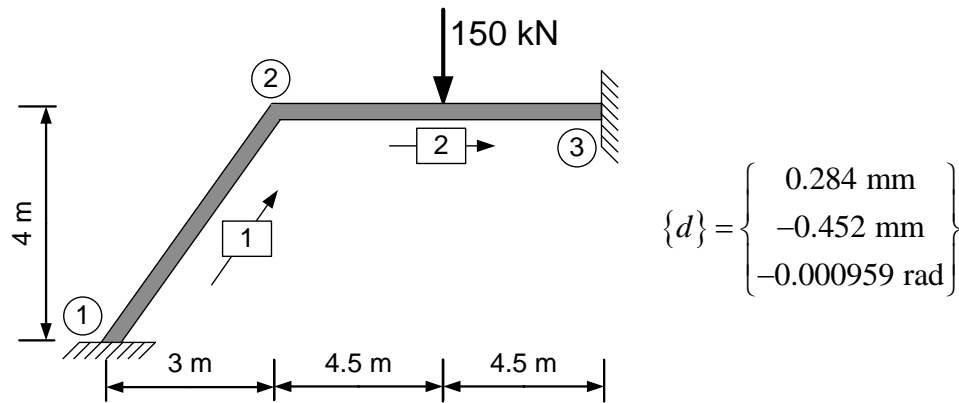

$$\{d\} = \begin{Bmatrix} 0.284 \text{ mm} \\ -0.452 \text{ mm} \\ -0.000959 \text{ rad} \end{Bmatrix}$$

Fig. 4

5. (20 marks)

A fixed-ended beam has an intermediate support at joint 2 as shown in Fig. 5. Support 2 is a distance of  $2.54 \text{ mm}$  below an axis drawn between joints 1 and 3. Determine the member end forces when the beam is jacked into position (with support 2 attached to the beam).  $EI = \text{constant} = 2.9 \times 10^3 \text{ kN}\cdot\text{m}^2$ .

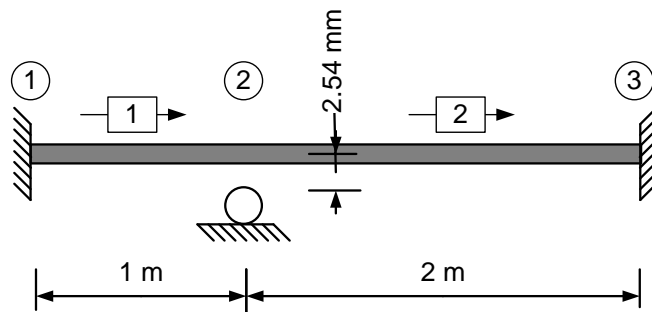

Fig. 5