

COMM 225: REVIEW QUESTIONS – WINTER 2012
(THIS INCLUDES QUESTIONS SELECTED FROM PAST MIDTERM EXAMS)

TOPIC: PROJECT MANAGEMENT

Q1.1: An important client of RoboTech has asked for a redesign and redevelopment of one of RoboTech's industrial robots. The client wants to see a demonstration, a technical proposal and a cost proposal as soon as possible. The project team at RoboTech has identified the tasks involved as indicated in the table below. The activities and their predecessors are listed as follows:

Activity	Description of the activity	Predecessor	Duration (days)
A	designing the robot	-	20
B	Building the prototype	A	10
C	testing the prototype	B	8
D	estimating the material costs	A	11
E	refining the design	C,D	7
F	demonstration	E	6
G	estimating labor	D	12
H	preparing the technical proposal	E	13
I	submission of the proposal	G,H	5

- (a) List all the paths and their durations. Identify the critical path(s).
 (b) Determine the critical path(s) using early start, early finish, late start and late finish times. Also identify all the critical and non-critical activities.

Q1.2: Refer to the following completion time estimates for each activity of a project.

Activity	Predecessor	Time Estimates (Weeks)		
		Optimistic	Probable	Pessimistic
1	-	8	8	8
2	1	11	12	13
3	2	9	10	12
4	3	5	7	10
5	1	5	6	7
6	5	14	18	26
7	6	8	10	14
8	5	13	13	13
9	8	10.5	13	15.5
10	1	10	12	14
11	10	7	10	12
12	11	10	11	12
13	12	6	6	6

- (a) Calculate the expected duration of each activity. Calculate the expected duration of each path.
 (b) Calculate the variance of each activity and variance of each path. Also, calculate the standard deviation of each activity and the standard deviation of each path.
 (c) Identify the critical path(s) (based on the expected durations).
 (d) What is the probability that the project can be completed within 49 weeks? What is the probability that the project will NOT be completed within 49 weeks?
 (e) What is the probability that the project will require 47 weeks or more? What is the probability that the project will NOT require more than 47 weeks?
 (f) What is the probability that the project will be completed between 45 and 50 weeks?

Q1.3: Fantasy products marketing manager has recently learned that its competitor is also in the process of developing a similar (new) product, which it intends to bring out to the market at exactly the same time and at lower price. The manager needs to decide whether to introduce the new product to the market 18 weeks from now. As a project management specialists, answer the following questions to help the marketing manager make a decision: When would the project be completed using normal durations?

- (a) Is it possible to complete the project in 18 weeks? What would the additional costs be? Which activities would need to be completed on a crash basis?
- (b) Crash the project as much as possible. What is the optimum number of weeks to crash?
- (c) Furthermore, market research has shown that if the early introduction is accomplished, it will bring a profit of \$10,000 per week. Would you recommend some time frame shorter than 18 weeks? Justify your answer with appropriate calculation.

Activity	Immediate Predecessors	Activity Duration (Weeks)		Activity Costs (\$)	
		Normal	Crash	Normal	Crash
A	-	3	2	2,000	4,000
B	A	8	6	9,000	12,000
C	B	4	2	2,000	7,000
D	-	2	1	1,000	2,000
E	D	2	1	2,000	3,000
F	E	5	5	0	0
G	C, F	6	3	12,000	24,000
H	-	4	2	3,500	8,000
I	H	4	3	5,000	8,000
J	H	3	2	8,000	15,000
K	J	4	3	50,000	70,000
L	I, K	6	6	10,000	10,000
M	G, L	1	1	5,000	5,000

Q 1.4: Given the following network and time and cost estimates, answer the following questions:

- (a) What is the project completion time?
- (b) What is the total cost required for completing this project on normal time?
- (c) Crash the project by three weeks and calculate the new project completion cost.

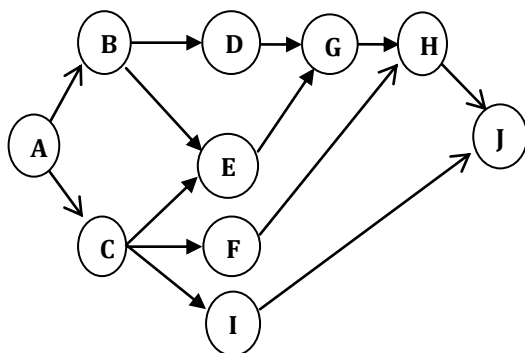

Activity	Immediate predecessor	Activity duration (Weeks)		Activity Cost (\$)	
		Normal	Crash	Normal	Crash
A	-	6	4	10000	16000
B	A	28	22	5000	9200
C	A	29	27	20000	20700
D	B	10	5	4000	6000
E	B,C	10	9	2500	3000
F	C	10	9	1000	7000
G	D,E	15	14	1500	7500
H	G,F	10	8	600	10600
I	C	2	1	1000	2000
J	H,I	10	8	900	8800

Q 1.5: The following table provides the necessary information for crashing a project. Project manager would like to crash the network by three weeks in the most economical way. Which activities should be crashed and by how many weeks?

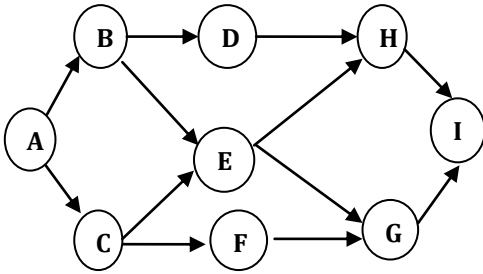

Activity	Activity duration (weeks)		Activity cost (\$)	
	Normal	Crash	Normal	Crash
A	4	3	4000	6000
B	3	2	5000	6000
C	2	1	2000	2800
D	5	3	4000	6000
E	6	5	2500	3000
F	3	2	1000	2000
G	4	3	2000	2900
H	4	3	1500	2600
I	6	5	5000	12000

Q 1.6: Kozar International, Inc. begun marketing a new instant-developing film project. The estimates of R&D activity time (weeks) for Kozar’s project are given in the table below. The project has two paths: A-C-E-F and A-B-D-F. Assume the activity times are independent.

- The company wants to be 95% confident that it can deliver the project without incurring any penalty, what time frame should it specify in the bid for project completion time?
- If the time to complete the path A-B-D-F is normally distributed, what is the probability that this path will take at least 38 weeks to be completed?

Activity	Predecessors	Time (Weeks)		
		Optimistic time	Probable time	Pessimistic time
A	-	9	9	9
B	A	8	10	12
C	A	9	12	18
D	B	5	8	11
E	C	5	7	10
F	D, E	10	12	14

Q 1.7: Given the following network and probabilistic time estimates, answer the following questions:

- Indicate the critical path and determine the expected project duration.
- The company wants to be 95% confident that it can deliver the project without incurring any penalty, what time frame should it specify in the bid for project completion time?
- What is the probability that the project will take at least 60 weeks to finish?

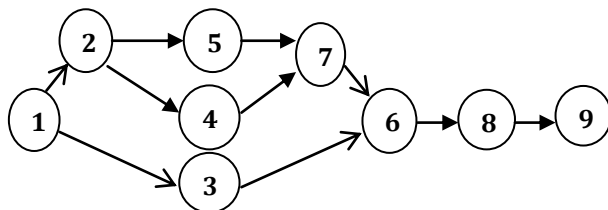

Activity	Estimated time (weeks)		
	Optimistic	Most likely	Pessimistic
1	10	10	10
2	5	5	5
3	10	18	20
4	4	4	4
5	3	3	3
6	6	7	8
7	8	9	10
8	6	10	14
9	10	14	18

TOPIC: FORECASTING

Q2.1: Monthly sales for National Mixer, Inc. for a seven-month period were as follows:

Month (T)	Feb.	Mar.	Apr.	May	June	Jul.	Aug.
Sales (1000 UNITS)	19	18	15	20	18	22	20

Forecast the sales volume for September using each of the following method:

- 5-month moving average;
- Weighted average, where the weights are - 0.60 (August), 0.30 (July), 0.10 (June)
- Exponential smoothing with a smoothing constant equal to 0.20
- Linear trend equation, $Y = 16.86 + 0.5 * T$;

Q2.2: The following past data is available on the weekly demand for a product:

Week (T)	1	2	3	4	5	6	7	8	9	10
Demand	150	157	162	166	177	185	192	197	209	214

- Forecast the demand for weeks 4-12 using 3-period moving average method.
- Forecast the demand for weeks 1-12 using exponential smoothing with $\alpha = 0.2$ (assume the first week's forecast to be equal to the first week's demand).
- Forecast the demand for weeks 1-12 using linear trend, $Y = 140.87 + 7.28 * T$.

Q2.3: Two independent methods of forecasting based on the managers experience have been prepared each month for the past 10 months. The forecasts and actual sales are as follows. Which forecast seem superior? Justify your answer with appropriate calculations.

Month	Forecast 1	Forecast 2	Actual Sales
1	771	769	770
2	785	787	789
3	790	792	794
4	784	798	780
5	770	774	768
6	768	770	772
7	761	759	760
8	771	775	775
9	784	788	786
10	788	788	790

Q2.4: Sales of CD-ROM sales over the past 12 weeks are shown in the following table. The manager has decided to use single exponential smoothing to forecast sales using a smoothing constant of either 0.10 or 0.40. Using the data from weeks 1 through 7, determine which smoothing constant would produce the smaller errors.

Week	1	2	3	4	5	6	7	8	9	10	11	12
Sales	40	44	46	43	45	44	40	43	44	42	46	45

Q2.5: Consider the demand for a chemical in a pulp and paper industry in the first 10 months of 1998.

Month:	Jan	Feb	March	April	May	June	July	August	Sept.	October
Demand	10	10	66	32	34	18	24	9	14	48

Forecast November sales volume using each of the following:

- (1) 3-month moving average;
- (2) 5-month moving average;
- (3) Exponential smoothing with a smoothing constant equal to 0.10;
- (4) Linear trend (Regression), $Y = 25 + 0.2727 \cdot T$; where T refers to the month 1, 2, 3,...
- (5) Which forecast seem superior? Justify your answer with appropriate calculations.

Q 2.6: Mr. Harvey wishes to compare forecasts using different forecasting approaches. Demand for a particular product had shifted downward last April because of a price increase. The following numbers of units were demanded in the past 10 months:

Month	Units	Month	Units
January	891	June	798
February	899	July	775
March	909	August	782
April	867	September	769
May	829	October	765

- (a) Using a smoothing constant of 0.3, prepare an exponential smoothing forecast of the data. Assume an initial value of 891.
- (b) Using a smoothing constant of 0.1, prepare an exponential smoothing forecast of the data. Assume an initial value of 891.
- (c) Compare the smoothed forecasts in parts (a) and (b). Does a decrease in the smoothing constant make the forecasting model less sensitive or more sensitive to a shift in demand?
- (d) If the random movements in monthly demand are relatively large, would it be better to set the smoothing constant relatively high or relatively low? Explain.
- (e) Forecast demand for November.

Q 2.7: The following past data is available on the monthly demand for a product:

Period	1	2	3	4	5	6	7	8	9	10	11	12
Demand	215	250	275	285	350	285	305	300	300	380	350	325

- (a) Using adjusted exponential smoothing with $\alpha = 0.4$ and $\beta = 0.1$, determine the forecast for period 13.
- (b) Suppose that the actual demand for period 13 turned out to be 395. What would be your forecast for period 14 at the end of period 13? What would be your forecast for period 15 at the end of period 13?

Q 2.8: The following past data is available on the weekly demand for a product:

Week (t)	1	2	3	4	5	6	7	8	9	10
Demand	150	157	162	166	177	185	192	197	209	214

- (a) Forecast the demand for weeks 1-12 using linear trend, weeks 1-12 using exponential smoothing with $\alpha = 0.2$ (assume the first week's forecast to be equal to the first week's demand) and weeks 4-12 using 3-period moving average method.
- (b) Plot the forecast and the actual demand data. Comment about using averaging techniques when actual demand has a trend.

TOPIC: INVENTORY MANAGEMENT

Q3.1: The Zertex Manufacturing Company produces fertilizer to sell to wholesalers. One raw material, calcium nitrite, is purchased from a supplier located near Zertex’s plant. 5,750,000 tons of calcium nitrite is forecast to be required next year to support production. If calcium nitrite costs \$22.50 per ton, carrying cost is 40% of acquisition cost, and ordering cost is \$595 per order:

- (a) In what quantities should Zertex buy calcium nitrite?
- (b) What annual stocking costs will be incurred if calcium nitrite is ordered at EOQ?
- (c) How many orders per year must take place for calcium nitrite?
- (d) How much time will elapse between two orders?

Q3.2: A large automobile repair shop installs about 1250 mufflers per year, 18% of which are for imported cars. All the imported car mufflers are purchased from a single local supplier at a cost of \$18.50 cents each. The shop uses a holding cost based on a 25% annual interest rate. The setup cost for placing an order is estimated to be \$28.

- (a) Determine the optimal number of imported-car mufflers the shop should purchase each time an order is placed, and the time between the placement of orders.
- (b) If the replenishment lead time is six weeks, what is the reorder point based on the levels of on-hand inventory?
- (c) The current reorder policy is to buy imported-car mufflers only once a year. What are the additional holding and setup costs incurred by the policy?

Q3.3: A consumer electronics store that sells a flash drive knows that the annual demand for this drive is fairly constant at 5000 units/year at the selling price of \$30/unit. The manufacturer of this drive charges a delivery fee of \$200 for each order, regardless of the number delivered. In addition, in-house costs associated with each order (e.g., unloading, order processing) total \$50. The inventory holding costs have been estimated at 20 cents/dollar/year. The manufacturer charges \$20/unit for 0-1000 units ordered, but is willing to give a discount of 3% per unit for all units on order sizes between 1001-2000 units and 5% per unit for all units on order sizes of 2001 units or more. What order size will maximize the profit for the store from sales of this flash drive, and what will be the profit at that order size?

Q3.4: A mail ordering company uses 800 boxes a year. The boxes can be purchased from either the supplier A or supplier B. Holding cost is 25% of unit cost and the ordering cost is \$ 40 per order. The quantity discounts are shown in the table below:

Supplier A		Supplier B	
Quantity	Unit Price	Quantity	Unit Price
1-199	\$14.00	1-149	\$14.10
200-499	\$13.80	150-349	\$13.90
500+	\$13.60	350+	\$13.70

Which supplier should be used and what is (a) the optimal order quantity and (b) the number of orders per year if the intent is to minimize the total annual cost.

Q3.5: A electronic retailer stocks a popular model of alarm clock in his warehouse. The lead time has been so stable in the past year that it is safely assumed to be a constant 9 days. Past data also indicates that the probability distribution of the daily demand is approximately normal with a mean of 20 and a variance of 16.

- a) What are the ordering point and the safety stock that provides a 96% service level?
- b) The ordering point is arbitrarily set to 189 clocks by the manager. What is the corresponding service level?
- c) Determine the safety stock that is needed to attain a 1% risk of stockout during lead-time.

Q3.6: A product with an annual demand of 1,000 SKUs has ordering cost of \$30/order and unit annual carrying cost = \$8. The demand exhibits some variability such that the lead-time demand follows a normal distribution, with a mean of 25 and a standard deviation of 5.

- (a) What is the recommended order quantity?
- (b) What are the reorder point and safety-stock level if the firm desires at most a 2-percent probability of a stockout on any given order cycle?

- (c) If the manager sets the reorder point at 30, what is the probability of a stockout on any given order cycle? How many times would you expect to stockout during the year if this reorder point were used?

Q3.7: The Sum and Yang (SY) produces copper contacts that is uses in switches and relays. SY needs to determine the order quantity Q to meet the annual demand at the lowest cost. SY consumes 5000 kg per month. The holding cost is 28% per year and ordering cost is \$30 per order. The price of copper depends on the quantity ordered. The following are the price-break data and other relevant data for the problem:

Order Quantity (Kg)	Price per Kg
$0 \leq Q \leq 3999$	\$1.00
$4000 \leq Q \leq 5249$	0.81
$5250 \leq Q \leq 6999$	0.80
$7000 \leq Q \leq 19,999$	0.79
$Q \geq 20,000$	0.78

Q 3.8: The Friendly Sausage Factory (FSF) can produce European Wieners at a rate of 2000 kg per week. FSF supplies wieners to local stores and restaurants at a steady rate of 150 kg per day. The cost to prepare the equipment for producing wieners is \$50. Annual holding cost is \$ 5 per kg of wiener. The factory operates throughout the year.

- Determine the optimal run quantity, total annual inventory cost, the number of production runs per year.
- If the factory has only enough storage space to hold a maximum of 300 kg in inventory, how will that effect the total inventory costs? (show your complete calculation)

Q 3.9: Allen's Shoe store carries a basic black dress shoes for men that sell at an approximate constant rate of 1000 pairs of shoes every three months. Allen's current buying policy is to order 500 pairs each time an order is placed. It costs \$500 to place an order, an inventory- carrying costs have an annual rate of 20 percent. Lead time is one month.

- What are the estimated annual inventory-holding and -ordering costs associated with this product?
- What is the cycle time for this product?
- What is the re-order point for this policy?
- Allen's supplier offered to reduce the price by 15% if the order size is doubled. What is your recommendation for Allen?

Q 3.10: The Old Town Microbrewery makes Towside beer, which it bottles and sells in its adjoining restaurant. It costs \$1700 to setup, brew, and bottle a batch of the beer. The annual cost to store the beer in inventory is \$1.25 per bottle. The annual demand for beer is 21,000 bottles and the brewery has the capacity to produce 30,000 bottles annually.

- Determine the optimal ordering quantity, total annual inventory costs, and the number of production runs per year.
- If the microbrewery has only enough storage space to hold a maximum of 2500 bottles of beer in inventory, how will that effect the total inventory costs?

Q 3.11: Bell computers purchases integrated chips at \$350 per chip. The annual holding cost rate is 10%, the ordering cost is \$120 per order, and sales are steady, at 400 per month. The company's supplier, Rich Blue Chip Manufacturing, Inc., decides to offer price concessions in order to attract larger orders. The price structure is given in the table below. What is the optimal order quantity and the minimum cost for Bell Computers to order, purchase, and hold these integrated chips?

Quantity Purchased	Price per unit
1-99 units	\$350
100-199 units	\$325
200 or more	\$300

Q 3.12: Brauch's Pharmacy has an expected annual demand for a leading pain reliever of 800 boxes, which sell for \$6.50 each. Each order costs \$6.00, and the inventory carrying charge is 20 cents. The expected demand during the lead time is normal, with a mean of 25 and a standard deviation of 3. Assuming 52 weeks per year, what reorder point provides a 95-percent service level? How much safety stock will be carried? If the carrying charge were 25 cents instead, what would be the total annual inventory-related cost?