

Carleton University
Mechanical and Aerospace Engineering
MAAE 2400 Thermodynamics and Heat Transfer

PROBLEM ANALYSIS QUESTIONS

Last revised: December 2010

PA QUESTIONS 1 -Specific Fuel Consumption and Thrust Specific Fuel Consumption (SFC and TSFC)

$$SFC = \frac{\text{mass of fuel consumed}}{\text{useful work output}} = \frac{\text{mass flow rate of fuel}}{\text{power output}} \qquad TSFC = \frac{\text{mass flow rate of fuel}}{\text{thrust}}$$

Specific gravity is defined as the actual fluid density over a reference density

Reference density for liquid = density of water at 4°C

Reference density for gases = density of air at 15°C at 101.325 kPa

Typical units for SFC	- Imperial: (lbm/h)/hp	- SI: (kg/s)/kW
for TSFC	- Imperial: (lbm/h)/lbf	- SI: (kg/s)/kN

1.1 Evaluate the specific fuel consumption of each of the following power plants:

- a) An oil engine for a submarine develops 1200 kW. Its rate of fuel consumption is 5 kg/min. (Ans. 6.94×10^{-5} kg/kWs)
- b) A gas engine drives a dynamo which delivers 120 amperes DC at 110 volts. The gas is obtained from a gas-producing plant which is fed with coke at the rate of 150 kg in 8 hours. (Ans. 3.95×10^{-4} kg/kWs)
- c) A gasoline engine drives a motor car at an average speed of 40 miles per hour against a total resisting force of 275 lbf. Its gasoline consumption is 20 miles per (Imperial) gallon. The specific gravity of gasoline is 0.73. (Ans. 0.5 lbm/hp hr)
- d) A gas turbine engine is used as a standby for peak load power production in a generation station. The shaft power delivered by the engine is 63 hp/(lbm/s of air). The rate of air flow through the engine is 140 lbm/s and the fuel flow rate is 105 lbm/min. (Ans. 0.714 lbm/hp hr)

1.2 The performance of aircraft propulsion devices is often expressed in terms of the number of pounds mass of fuel consumed per hour per pound force of thrust developed. Compare the following on this basis:

- a) A rocket carries a total fuel load of 60 tons mass. The rocket engine operates steadily for 2.5 minutes and develops a thrust of 150 tons force. (Ans. 9.6 lbm/lbf hr)
- b) An aircraft powered by four gas-turbine jet engines consumes 30,000 (Imperial) gallons of kerosine on a flight of 3500 miles when flying at a steady speed of 550 miles per hour. Each engine develops a thrust of 10,000 pounds force. The specific gravity of kerosine is 0.81. (Ans. 0.955 lbm/lbf hr)

- c) An aircraft is powered by a gas turbine propeller engine. In level flight at constant speed the engine consumes 16 pounds mass of kerosine per minute and the drag of the aircraft is 1770 pounds force. (Ans. 0.542 lbf/lbf hr)

1.3 An electricity supply for use in isolated districts incorporates a lead-acid secondary cell (the accumulator) which may be charged periodically by means of a DC generator driven by a gasoline engine. The average load on the accumulator during discharge at 100 V is 40 A for 6 hours per day. During charging the generator output is 33 A at 115 V. The charging period is 8 hrs/day and the weekly gasoline consumption of the engine is 110 litres. The specific gravity of the gasoline is 0.73. Determine,

- a) the power delivered by the accumulator during discharge (in kW); (Ans. 4 kW)
- b) the power delivered to the accumulator during charging (in kW); (Ans. 3.8 kW)
- c) the specific fuel consumption of the accumulator plus charging plant (in kg of fuel per kW-hrs). (Ans. 1.046×10^{-4} kg/kWh)

PA QUESTIONS 2 - Work at a Moving Boundary

2.1 Compute the work performed when 8 ft³ of gas expands to a volume of 20 ft³ under a constant pressure of 300 psia. Draw a pressure-volume diagram for the process.

(Ans. 5.184×10^5 ft-lbf)

2.2 A process occurs for which the pressure changes according to the equation $p = 288V + 900$, where p is expressed in psia if V is in ft³ units. If the volume changes from 10 to 20 ft³, how much work is done?

(Ans. 7.5×10^6 ft-lbf)

2.3 Air expands in a container according to the relationship $pV^{1.4} = \text{Constant}$, from an initial volume of 5 L and a pressure of 500 kPa to a final volume of 10 lt. Compute the work done in this process.

(Ans. 1.5 kJ)

2.4 A vapour in a cylinder is compressed frictionlessly from 150 kPa and 4 L to 750 kPa in such a manner that $pV = \text{constant}$. Sketch the process on p - V coordinates and compute the work done.

(Ans. -966 J)

2.5 Evaluate the magnitudes and signs of the heat transfer and of the work in the following processes. (The system to be considered is given in capital letters.)

a) A well-insulated, sealed vessel contains 0.001 kg of fuel oil and some oxygen gas. The oil ignites, causing a rise in the temperature of the VESSEL AND ITS CONTENTS.

(Ans. $Q = 0, W = 0$)

b) A SEALED CALORIMETER containing powdered coal is immersed in a tank containing 1 kg of water. In the first half minute after ignition of the coal, the water temperature rises by 0.5°C.

Take $C_p = 4.2$ kJ/kg K.

(Ans. $W = 0, Q = -2.1$ kJ)

2.6 State whether the heat transfer (Q) and the work transfer (W) are positive, negative or zero in each of the following processes. The systems to be considered are given in capital letters.

- a) A rigid steel vessel containing STEAM at a temperature of 300°F is left standing in the atmosphere which is at a temperature of 80°F .

(Ans. $W = 0$, Q neg.)

- b) 0.05 kg of GAS contained in an insulated cylinder expands as the piston moves slowly outwards.

(Ans. W pos., $Q = 0$)

- c) A MIXTURE OF ICE AND WATER is contained in a vertical cylinder closed at the top by a piston; the upper surface of the piston is exposed to the atmosphere. The piston is held stationary while a flame, applied to the base of the cylinder, causes some of the ice to melt.

(Ans. $W = 0$, Q pos.)

- d) As under (c), but the piston is allowed to move so as to keep the mixture pressure constant.

(Ans. W neg., Q pos.)

- e) A MIXTURE OF ICE AND WATER is contained in an insulated vertical cylinder closed at the top by a non-conducting piston; the upper surface is exposed to the atmosphere. The piston is held stationary while the mixture is stirred by means of a paddle wheel protruding through the cylinder wall. As a result some of the ice melts.

(Ans. W neg., $Q = 0$)

- f) As under (e), but the piston is allowed to move so as to keep the mixture pressure constant.

(Ans. W neg., $Q = 0$)

- g) A rigid vessel containing AMMONIA GAS is connected through a valve to an evacuated rigid vessel. The vessels, the valve and the connecting pipe are well insulated. The valve is opened and after some time, conditions throughout the two vessels become uniform.

(Ans. $W = 0$, $Q = 0$)

- h) ONE POUND OF AIR flows adiabatically from the atmosphere into a previously evacuated bottle.

(Ans. $W = 0$, $Q = 0$)

2.7 Consider the piston and cylinder arrangement shown in the figure, in which a frictionless piston with a cross-sectional area of 0.4 m^2 rests on stops on the cylinder walls such that the contained volume is 0.2 m^3 . 170 kPa pressure is required to raise the piston against the atmospheric pressure and the piston weight. When the piston has moved to a point where the contained volume is 0.6 m^3 , it encounters a linear spring with a spring constant of 350 kN/m . The piston continues to move until the pressure is 600 kPa .

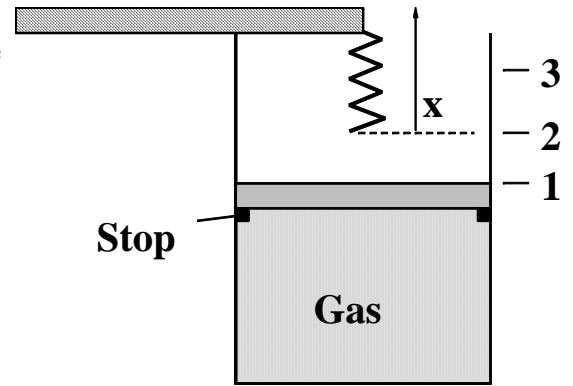

- Considering the gas inside as the system, show the process on a p-V diagram.
- Calculate the work done by the system. (Ans. 143.7 kJ)

2.8 A vertical U-tube has a circular cross section with a diameter of 0.8 cm . One leg of the U-tube is capped and the other is open to atmosphere. Mercury in the U-tube traps CO_2 in the closed leg so that the mercury level is 25 cm below the capped end (Figure 1). Atmospheric pressure is 101.3 kPa . The CO_2 is heated so that it expands until the level of the mercury in that leg is lowered to 45 cm below the capped end (Figure 2).

- Derive an expression that relates the pressure of the CO_2 to its volume at any instant during the expansion process.

$$\text{(Ans. } p = p_1 + 2\rho g \left(\frac{V - V_1}{A} \right) \text{)}$$

- Calculate the work done by the CO_2 as it expands. (Ans. 1.42 J)
- Show the process on a p-V diagram.

For the specific gravity of mercury use 13.6 .

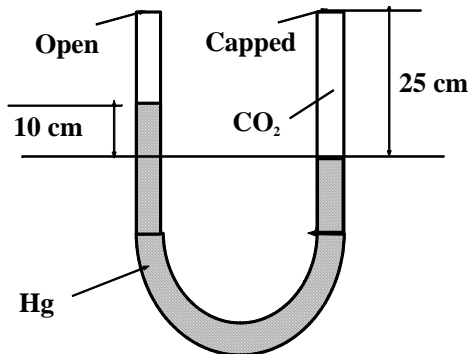

Figure 1

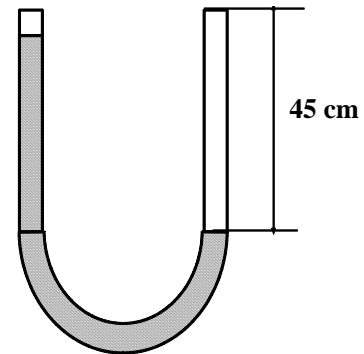

Figure 2

PA QUESTIONS 3 - First Law for Cyclic and Non-Cyclic Processes

3.1 For each of the following five cases of processes of a closed system, fill in the blanks: (Note: Q is positive if supplied to the system and W is positive if done by the system.)

	Q	W	E ₁	E ₂	$\Delta E = E_2 - E_1$
a	10 kJ	5 kJ	71 kJ	76	5
b	10 kJ	-5 kJ	60 kJ	85	15
c	25 kJ	-10 kJ	-45	-10 kJ	35
d	37	20 kJ	55 kJ	72	17 kJ
e	-10 kJ	-30	45	65 kJ	20 kJ

3.2 A closed system passes from state 1 to state 2 while 25 Btu of heat is added and 35 Btu of work is done by the system. As the system is returned to state 1, 20 Btu of work is done on it. What is the heat transfer during process 2-1?

(Ans. -10 BTU)

3.3 The internal energy of a fluid in a closed system changes from 500 to 440 Btu/lbm while the fluid performs 30,000 ft-lb/lbm of work. Calculate the heat transfer. Be sure to state the sign or direction of the heat transfer.

(Ans. -21.4 BTU/lbm; i.e. from system)

3.4 During the expansion of 30 kg of gas in a closed system, heat is added to the gas in the amount of 420 kJ. The internal energy decreases by 1200 kJ. Calculate the work.

(Ans. 54 kJ/kg)

3.5 During a process of a closed system, 1000 kJ of heat is removed and there is a decrease of 200 kJ in the internal energy. Calculate the work.

(Ans. -800 kJ)

3.6 Calculate the work of a closed-system process during which 50 Btu of heat is added to the system and the stored energy of the system increases by 300 Btu.

(Ans. -250 BTU)

3.7 An expanding gas does 6000 ft-lb of work while it receives 10 Btu of heat. Calculate the change in its stored energy.

(Ans. 2.3 BTU)

3.8 During a process of a closed system, 200 kJ of heat is added to the system and the stored energy of the system increases by 150 kJ. During the return process, which restores the system to its initial state, 80 kJ of work is done on the system. Determine the heat transfer of the return process.

(Ans. -230 kJ)

3.9 A window air conditioner is designed to remove 13 MJ/hr from the room, and 900 W of electrical work must be delivered to the unit to accomplish this cooling. How much heat is dissipated to the surroundings under these conditions.

(Ans. 16,240 kJ/hr)

3.10 Heat is added to a closed system which is constructed so that the pressure will remain constant. During a process in which 850 kJ of heat is added, the system produces 200 kJ of work output. What is the change of internal energy and enthalpy of the system?

(Ans. 650 kJ; 850 kJ)

PA QUESTIONS 4 - First Law for Steady Flow

For liquids $h(T, p) \approx h_f(T) + v_f(T)[p - p_{sat}(T)]$

If we neglect ΔT , we obtain $\Delta h = h_2 - h_1 = v_f(p_2 - p_1) = \frac{p_2 - p_1}{\rho_f}$

4.1 Air at 14.7 psia and 70°F is taken into a gas turbine powerplant at a velocity of 400ft/s through an opening of 1.2 ft² cross-sectional area. The air is compressed, heated, expanded through a turbine, and exhausted at 26 psia and 300°F through an opening of 1.0 ft² cross-sectional area. The power output is 500 hp.

Assuming air to be an ideal gas with a gas constant (R) equal to 53.34 lbf-ft/lbm^oR, a specific heat at constant volume (C_v) equal to 0.171 Btu/lbm^oR and a specific heat at constant pressure (C_p) equal to 0.24 Btu/lbm^oR, calculate the following:

- a) Density of air at inlet and exit in lbm/ft³. (Ans. 0.0749 lbm/ft³, 0.0924 lbm/ft³)
- b) Mass flow rate of air in lb/sec. (Ans. 35.95 lbm/s)
- c) Velocity of air at exit. (Ans. 389 ft/s)
- d) Change in internal energy between inlet and exit in Btu/lbm.(Ans. 39.33 Btu/lbm)
- e) Net amount of heat added to the air in Btu/lbm. (Ans. 64.86 Btu/lbm)

4.2 An air compressor with a volume flow rate of 10000 ft³/min at its inlet increases the pressure from 15 to 35 psia; heat is removed at the rate of 750 Btu/min. The inlet temperature is 70°F and the inlet velocity is negligible. The exit temperature is 280°F and the exit area is 0.20 ft². Find the power input (hp) necessary to operate the compressor under these conditions.
(Ans. 1015 hp)

4.3 A turbine is supplied with 20,000 lb/hr of a fluid. The inlet and exit fluid velocities are 6000 ft/min and 24,000 ft/min, respectively. If the initial and final enthalpy values are 1260 and 1000 Btu/lbm, respectively, and the heat loss amounts to 140,000 Btu/hr, calculate the power output.
(Ans. 1965 hp)

4.4 Steam expands through a nozzle from a pressure of 200 psia to a final pressure of 2 psia. The initial and final enthalpy values are 1289 and 955 Btu/lbm, respectively. Neglecting the initial velocity and heat losses, calculate the final velocity.
(Ans. 4091 ft/s)

4.5 The flow rate through a hydraulic turbine is $6 \text{ ft}^3/\text{s}$. The pressure of the water is 30.6 psig at the inlet which has a cross-sectional area of 0.5 ft^2 . At the outlet, 8 ft below the inlet, the velocity is 2.5 ft/s , and the pressure is 4 psig . Calculate the power imparted to the turbine by the fluid.

(Ans. 48.7 hp)

4.6 A gas enters a compressor at 14 psia , 80°F ($h = 129 \text{ Btu/lbm}$, $u = 92 \text{ Btu/lbm}$, $v = 14.3 \text{ ft}^3/\text{lbm}$) with negligible velocity and is discharged at 70 psia , 500°F ($h = 231 \text{ Btu/lbm}$, $u = 165 \text{ Btu/lbm}$). The gas leaves the compressor with a velocity of 500 ft/s . The power input is 3200 hp . The flow rate is 20 lb/sec . Determine the heat transfer in Btu/lbm .

(Ans. -6.1 Btu/lbm)

4.7 Carbon dioxide flows steadily through a machine at a rate of 0.5 lb/sec , entering with negligible velocity at 20 psia , 80°F ($u_1 = 67.2 \text{ Btu/lbm}$, $h_1 = 91.6 \text{ Btu/lbm}$). The gas leaves the machine at 60 psia , 200°F ($\rho_2 = 0.0116 \text{ slugs/ft}^3$, $u_2 = 85.8 \text{ Btu/lbm}$, $h_2 = 115.6 \text{ Btu/lbm}$), through an opening which has an area of 0.4 in^2 . Power input to the machine is 25 hp . Determine the amount of heat transfer per pound of carbon dioxide.

(Ans. -6.8 Btu/lbm)

4.8 Air enters a machine at 14.0 psia , 80°F ($\rho = 0.0701 \text{ lb/ft}^3$), with negligible velocity and is exhausted at 14.0 psia , 130°F ($\rho = 0.0641 \text{ lb/ft}^3$), with a velocity of 300 ft/s through an opening having a cross-sectional area of 0.01 ft^2 . The enthalpy of the air increases by 12.0 Btu/lbm , and its internal energy increases by 8.55 Btu/lbm . A blower delivers 1 hp to the air as it passes through the machine. Calculate the heat added to or removed from the air in Btu/lbm .

(Ans. 10.1 Btu/lbm)

4.9 Two air streams are mixed in a large chamber before passing through an air turbine as shown in the following figure. The exhaust of the turbine is discharged to the atmosphere. Assuming steady adiabatic flow and neglecting changes in kinetic and potential energies determine:

a) the temperature of the air at the turbine inlet (T_3);

(Ans. $T_3 = 543^\circ\text{F}$)

b) the temperature at the discharge of the turbine if the rotor of the turbine is stalled, that is, not rotating;

(Ans. $T_3 = T_4$)

c) the power developed by the turbine if the temperature at discharge is 100°F . Assume air to be a perfect gas.

(Ans. 534.7 hp)

$$C_p = 0.24 \text{ Btu/lbm}^\circ\text{F}, C_v = 0.171 \text{ Btu/lbm}^\circ\text{F}$$

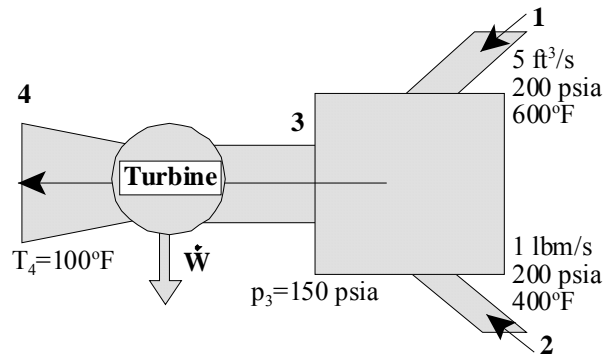

PA QUESTIONS 5 - Processes with Ideal Gases

5.1 Find the mass of air (rel. molar mass = 29.0 kg/kg-mol) which occupies a volume of 100 m^3 at atmospheric pressure (1.01325 bar) and a temperature of 20°C , assuming air is a perfect gas.

(Ans. 120.6 kg)

5.2 A certain mass of gas confined in a cylinder occupies 3 ft^3 at a pressure of 14.7 psia. If the gas is compressed at constant temperature until it occupies 1.2 ft^3 , find the final pressure.

(Ans. 36.8 psia)

5.3 What pressure will be exerted by 6 lbm of N_2 at 32°F if its volume is 12 ft^3 , assuming ideal gas behaviour?

(Ans. 94 psia)

5.4 1 kg of air is contained in a cylinder fitted with a leak-proof piston. The initial pressure and volume of the air are 200 kPa and 0.2 m^3 , respectively. The air expands slowly and frictionlessly at constant temperature to a final pressure of 100 kPa. Assuming the air inside the cylinder to be your system, calculate

- i) the heat exchanged;
- ii) the work done; and
- iii) the change of internal energy.

(Ans. (i) 27.7 kJ; (ii) 27.7 kJ; (iii) 0)

If the path between the same end states is changed such that the volume is first doubled at constant pressure then the pressure is halved at constant volume, calculate

- i) the change of internal energy for the air inside the cylinder;
- ii) the heat exchanged;
- iii) the work done.

(Ans. (i) $\Delta U = 0$; (ii) 40 kJ; (iii) 40 kJ)

5.5 0.001 m^3 of air is contained in a piston-cylinder assembly at 150 kPa and 15°C . It is first heated at constant volume (process 1-2) until the pressure has doubled. Then it is expanded at constant pressure (process 2-3) until the volume has tripled. Find the total heat added in kJ.

(Ans. 2.47 kJ)

5.6 An ideal gas has the following specific heat equations:

$$c_p = 0.25 + 0.0002 T \text{ Btu/lbm}^\circ\text{R} \quad \text{and} \quad c_v = 0.20 + 0.0002 T \text{ Btu/lbm}^\circ\text{R}$$

where T is in $^\circ\text{R}$. Some of this gas is trapped in a closed, rigid, thermally-insulated container at 10 psia and 40°F . A paddle wheel inside the container is turned by an external motor until the pressure of the gas reaches 15 psia. Determine

- a) the enthalpy change per pound;
- b) the heat transferred;
- c) the work done.

Indicate by sign whether the heat and work transfers are into or out of the gas.

(Ans. (a) 93.75 Btu/lbm; (b) 0; (c) -81.25 Btu/lbm)

5.7 A simple engine uses a perfect gas as the working fluid in a piston-cylinder system. The gas is first heated at constant pressure from state 1 to state 2, then cooled at constant volume to state 3 where $T_3 = T_1$, and then compressed at constant temperature, thereby returning to state 1. Develop an expression for the cycle efficiency [(net work output) / (energy input as heat)].

$$\eta = \frac{\gamma - 1}{\gamma} \cdot \left[1 + \frac{T_1 \ln(T_1 / T_2)}{T_2 - T_1} \right]$$

(Ans. $\eta = \frac{\gamma - 1}{\gamma} \cdot \left[1 + \frac{T_1 \ln(T_1 / T_2)}{T_2 - T_1} \right]$)

For further practice, the following problems are recommended from the course text book (Moran & Shapiro; 6th edition): 3.95, 3.100, 3.101, 3.106, 3.109

PA QUESTIONS 6 - Processes with Steam

6.1 In a non-flow system, dry saturated steam at 100 psia is heated at constant volume until its pressure is 160 psia. It is then expanded isothermally to 100 psia while adding 64.5 Btu/lbm heat. Finally, it is cooled at constant pressure until saturated.

Sketch these processes on a p-V diagram, approximately to scale. Calculate the heat interaction of steps 1 and 3 of the process, and the work done by the steam during each step of the process.

(Ans. 164.8 Btu/lbm, -216.8 Btu/lbm;
 $W_{1-2} = 0$, $W_{2-3} = 62.5$ Btu/lbm;
 $W_{3-1} = -50$ Btu/lbm)

6.2 Steam enters a turbine at 5 MPa, 350°C and leaves as dry saturated vapour at 7 kPa. The mass flow rate is 150 kg/hr, and the radiation heat loss from the turbine is 2 kJ/kg. Calculate the power output of the turbine in kW.

(Ans. 20.67 kW)

6.3 Water is heated in an insulated heat exchanger by mixing it with steam. The water enters at a rate of 100 kg/min at 19°C and 350 kPa. The steam enters at 300°C and 350 kPa. The mixture leaves the exchanger at 40°C and 330 kPa. How much steam is needed in kg/min?

(Ans. 3.0 kg/min)

6.4 Steam at 2 MPa is throttled to 100 kPa and 120°C. Calculate the quality of the steam at the 2 MPa condition. Assume that the throttling process is adiabatic and that the enthalpy of the fluid is constant across the throttle.

(Ans. 0.956)

6.5 A throttling calorimeter is connected to a steam line to sample steam at $p = 1.5$ MPa. After steam undergoes an adiabatic throttling process to $p = 100$ kPa, the temperature is measured as 105°C. Determine the quality of the steam at 1.5 MPa in the line.

(Ans. 0.946)

6.6 A frictionless, uninsulated piston separates air and H₂O in a cylinder. The initial volumes are equal, each being 10 ft³. The volume of liquid is initially 2 percent of the total volume of H₂O in container B. Heat is slowly transferred to the fluids (while the fluids remain at a constant pressure of 100 psia) until all the liquid in B evaporates.

- a) For the initial conditions, determine the mass of liquid and the mass of vapour in container B.

(Ans. 11.27 lbm, 2.21 lbm)

- b) Determine the work done by fluid B during this process.

(Ans. 921.3 Btu)

- c) Determine the total heat transferred.

(Ans. 10,025 Btu)

- d) Calculate the work done against the atmosphere by the fluids A and B combined (P_{atm} = 14.7 psia).

(Ans. 135.4 Btu)

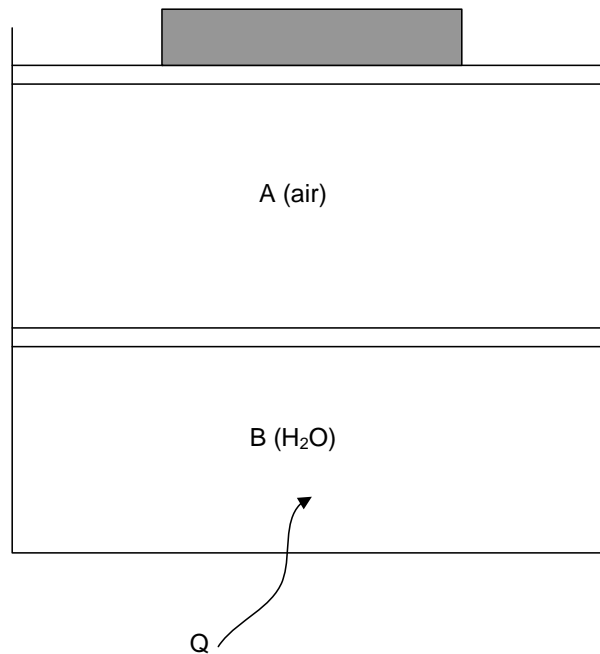

For further practice, the following problems are recommended from the course text book (Moran & Shapiro; 6th edition): 3.12, 3.17, 3.20, 3.24, 3.27

PA QUESTIONS 7 - Carnot Cycle, the Second Law and Entropy

- 7.1 A Carnot cycle receives 630 kJ of heat at 540°C and has an efficiency of 50 per cent. Calculate the work output and temperature at which heat is rejected.
(Ans. 315 kJ/133.5°C)
- 7.2 A Carnot cycle receives 1 MJ of heat at 800°C and rejects heat at 150°C. Calculate the work output.
(Ans. 0.605 MJ)
- 7.3 A reversed Carnot cycle is to be used as a refrigerator operating between the temperature limits of -18 and 20°C. Calculate the power input required to remove 3.5 kW from the low-temperature reservoir.
(Ans. 0.52 kW)
- 7.4 A Carnot cycle receives heat from a constant-temperature reservoir at 700 K and rejects heat to 5 kg of water which is initially saturated liquid at 100 kPa. As the engine operates, the water is heated at constant pressure until it becomes saturated vapour. Calculate the work output of the Carnot engine.
(Ans. 9935 kJ)
- 7.5 It is desired to produce refrigeration at -10°C. A reservoir is available at a temperature of 200°C and the ambient temperature is 30°C. Thus work can be done by a heat engine operating between the 200°C reservoir and the ambient, and this work can be used to drive the refrigerator. Determine the ratio of the heat transferred from the high temperature reservoir to the heat transferred from the refrigerated space, assuming all processes to be reversible.
(Ans. 0.42)
- 7.6 A heat engine operates on a Carnot cycle and receives 500 Btu from a reservoir at 1000°F, and rejects heat at 80°F.
- Show the cycle on a T-s diagram, considering the working fluid as the system.
 - Calculate the work and efficiency of the cycle.
(Ans. 315 Btu, 0.63)
 - Calculate the change in entropy of the high-temperature and low-temperature reservoirs per lbm.
(Ans. (High) -0.343 Btu/°R
(Low) +0.343 Btu/°R)

7.7 Prospective inventors frequently devise machines which are in violation of the second law. Suppose an inventor asks you to analyze his "new" device which will receive heat from boiling water at 100 kPa and reject heat at 20°C. He claims the device could achieve an efficiency of 75 per cent. How do you rate this claim? What is the maximum efficiency you would think is realistic?

7.8 Steam is throttled from 700 kPa, 75 percent quality, to 100 kPa. Calculate the increase in entropy.

(Ans. 0.68 kJ/kgK)

7.9 At steady state, steam with a mass flow rate of 10 lbm/s enters a turbine at $T_1 = 800^\circ\text{F}$ and $P_1 = 600$ psia and expands to $P_2 = 60$ psia. The power developed by the turbine is 2,852 hp. The steam then passes through a counterflow heat exchanger with a negligible change in pressure, exiting at $T_3 = 800^\circ\text{F}$. Air enters the heat exchanger in a separate stream at $P_4 = 20$ psia, $T_4 = 1020^\circ\text{F}$ and exits at $P_5 = 18$ psia, $T_5 = 620^\circ\text{F}$. Assuming negligible kinetic and potential energy changes and insignificant heat transfer between either component and its surroundings, determine,

a) the enthalpy of the steam at the turbine exit;

(Ans. 1206 Btu/lbm)

b) the rate of entropy production within the turbine;

(Ans. 0.459 Btu/s°R)

c) the mass flow rate of air; (assume $C_p = 0.257$ BTU/lbm°R for the air)

(Ans. 21.91 lbm/s)

d) the rate of entropy production within the heat exchanger.
(Ans. 0.605 Btu/s°R)

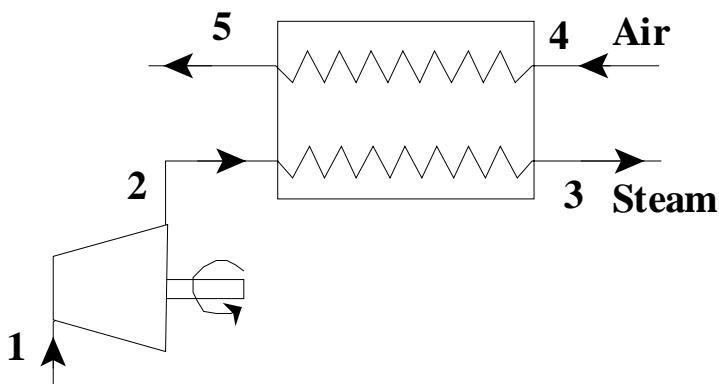

7.10 The two chambers shown in the figure initially have equal volumes of 28 liters and contain air and hydrogen, respectively. The chambers are separated by a frictionless, insulated piston. Both gases are initially at 140 kPa and 40°C. Heat is added to the air side until the pressure of both gases reaches 280 kPa. All outside walls are insulated except for the surface where heat is added to the air.

For the pressure and temperature ranges in question, both gases approximate ideal gas behaviour. Determine,

- a) the final temperature of the air and the hydrogen; (Ans. 597°C, 109°C)
- b) the amount of heat transferred to the air; (Ans. 19.6 kJ)
- c) the amount of work done on the hydrogen; (Ans. 2.15 kJ)
- d) the entropy change for the air and the hydrogen in kJ/K. (Ans. 0.03615 kJ/K, 0.0 kJ/K)

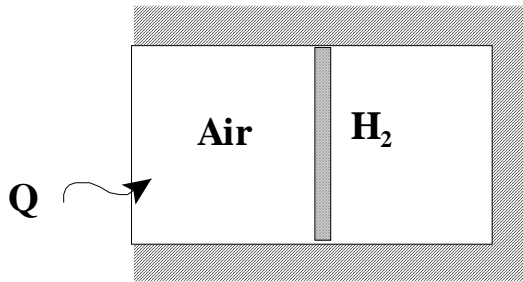

For hydrogen use:

$$k = 1.409 \quad R = 4.1243 \text{ kJ/kgK}$$

$$C_v = 10.0849 \text{ kJ/kgK} \quad C_p = 14.209 \text{ kJ/kgK}$$

7.11 A two-stage adiabatic steam turbine with inter-stage steam extraction is shown in the figure. The data are as shown on the schematic. The first and second stage isentropic efficiencies are 0.85 and 0.87, respectively. Determine,

a) the specific enthalpies at states 1, 2, 3, 4 and 5;

(Ans. 3625.3 kJ/kg, 3119.1 kJ/kg,
3119.1 kJ/kg, 3119.1 kJ/kg,
2476.9 kJ/kg)

b) the amount of entropy produced in the first stage (in kW/K);

(Ans. 2.2755 kW/K)

c) the amount of entropy produced in the second stage (in kW/K);

(Ans. 3.3264 kW/K)

d) the shaft power output from the two-stage steam turbine (in MW).

(Ans. 15.3 MW)

$P_1 = 10 \text{ MPa}$
 $T_1 = 600^\circ\text{C}$
 $\dot{m}_1 = 15 \text{ kg/s}$
 $\dot{m}_3 = 3 \text{ kg/s}$
 $P_2 = P_3 = P_4 = 1.5 \text{ MPa}$
 $P_5 = 30 \text{ kPa}$

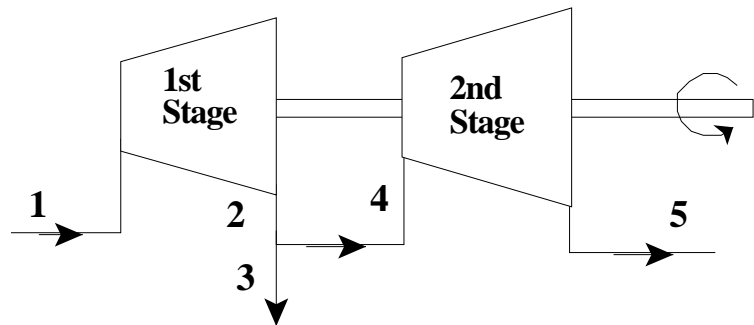

7.12 Air is compressed in a reversible steady state, steady flow process from 15 lbf/in^2 , 100°F to 100 lbf/in^2 . Calculate the work of compression and the heat transfer per pound of air compressed, assuming the following processes:

- a) Isothermal (Ans. -72.8 Btu/lbm , -72.8 Btu/lbm)
- b) Polytropic, $n = 1.25$ (Ans. -88.6 Btu/lbm , -26.6 Btu/lbm)
- c) Adiabatic (Ans. -96.7 Btu/lbm , 0 Btu/lbm)
- d) Show all these processes on a P-V diagram.

7.13 A turbocharger is used to boost the inlet air pressure to an automobile engine. It consists of an exhaust-gas driven turbine directly connected to an air compressor, as shown in the figure. The conditions shown in the figure correspond to a certain engine load. Assume the following:

- the exhaust gas properties are the same as those of air;
- potential and kinetic energy changes across the turbine and the compressor are negligible;
- the flows through the turbine and the compressor are frictionless and adiabatic.

Determine,

- a) the turbine exit temperature; (Ans. 500°C)
- b) the turbine power output; (Ans. 15 kW)
- c) the compressor exit pressure and temperature. (Ans. 277 kPa , 127°C)

$P_1 = 101.3 \text{ kPa}$
 $T_1 = 27^\circ\text{C}$
 $\dot{m}_1 = 0.15 \text{ kg/s}$
 $P_3 = 155 \text{ kPa}$
 $T_3 = 600^\circ\text{C}$
 $P_4 = 101.3 \text{ kPa}$
 $\dot{m}_4 = 0.15 \text{ kg/s}$

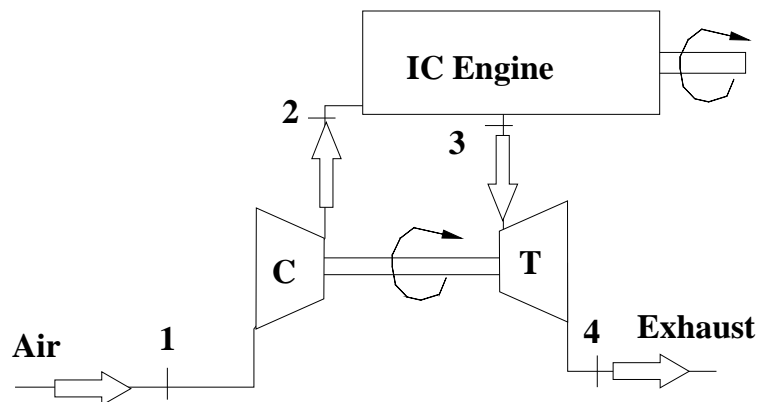

For further practice, the following problems are recommended from the course text book (Moran & Shapiro; 6th edition): 5.26, 5.29, 5.38, 5.56, 5.61, 6.11, 6.34, 6.35, 6.43

PA QUESTIONS 8 - Gas Power Cycles

8.1 A gas turbine power cycle operates with a pressure ratio of 12:1. The compressor and turbine efficiencies are 85 and 90 percent, respectively. The compressor inlet temperature is 20°C, and the turbine inlet temperature is 1500 K. For a mass flow rate of 1 kg/s, find the power generated by the cycle and the thermal efficiency. Now double the pressure ratio. What are the power output and the thermal efficiency in this case?

(Ans. 331.5 kW; 38.8%, 297 kW; 42.4%)

8.2 At the beginning of compression of an air-standard Otto cycle the pressure is 14 psia and the temperature is 80°F. At the end of compression the pressure has risen by a factor of 15.3 and during the combustion process 497 Btu/lbm of heat is added.

Determine (a) the compression ratio, (b) the temperature at the end of the compression in °R, (c) the temperature at the end of expansion in °R, (d) the work output during expansion in Btu/lbm, (e) the work input of the cycle, and (f) the thermal efficiency.

(Ans. 7.0, 1177°R, 1864°R, 376 Btu/lbm, -108 Btu/lbm, 54.1%)

8.3 A gas turbine engine is being designed to power a small helicopter. Conditions at an altitude of 1000m are being considered. At this altitude ambient pressure and temperature are 87.5 kPa and 7°C, respectively.

At this altitude the engine is to have a power output of 450kW. Ambient air enters the compressor. The design pressure ratio is 19:1. Compressor and turbine efficiencies are estimated at 0.83 and 0.89, respectively. Turbine inlet temperature is to be 1200 K.

- Sketch the cycle in T-S coordinates. Label all pertinent state points.
- Determine the thermal efficiency of the engine.
- Determine the required mass flow rate of air through the engine, in kg/s.
- Determine the required fuel flow rate, in kg/s, if the fuel has a heating value of 39500kJ/kg.

(Ans. 34.2%, 2.8 kg/s, 0.0334 kg/s)

8.4 A gas turbine is used to provide power on an Arctic pipeline. The atmospheric temperature and pressure are -30°F and 14.7 lbf/in², respectively. The turbine inlet temperature is 1700°F, the pressure ratio is 10.0 and both the compressor and turbine have isentropic efficiencies of 87 percent. Calculate the power output for an air flow of 200 lb/s. What is the thermal efficiency?

(Ans. 30,282 hp; 0.35)

If the compressor efficiency was reduced to 81 percent because of icing damage, calculate the power assuming everything else to be unchanged. Comment on the significance of your result.

(Ans. 27,960 hp)

Assume air throughout ($C_p = 0.240$ Btu/lbm°R, $C_v = 0.171$ Btu/lbm°R).

PA QUESTIONS 9 - Vapour Power & Refrigeration Cycles

- 9.1 A geothermal power plant in California uses steam produced underground by natural sources. Steam enters the adiabatic turbine at 200°C , 550 kPa, and emerges at 14 kPa with 8 per cent moisture (92 per cent quality). It is then condensed at 14 kPa and then pumped back up to atmospheric pressure. The plant produces 12.5 MW of electric power. Determine the steam flow rate and the condenser heat-transfer rate. Why do you think the system has the condenser? Why does it need the pump?

(Ans. 28 kg/s; 61 MW)

- 9.2 In certain situations, when only superheated steam is available, a need for saturated steam may arise for a specific purpose. This can be accomplished in a desuperheater, in which case water is sprayed into the superheated steam in such amounts that the steam leaving the superheater is dry saturated. The following data apply to such a desuperheater, which operates as a steady flow process. Superheated steam at 2000lbm/hr, 400 psia, and 600°F enters the desuperheater. Water at 420 psia, 100°F also enters the desuperheater. The dry saturated vapour leaves at 380 psia. Calculate the rate of flow of water.

(Ans. 178.3 lbm/hr)

- 9.3 Steam enters a turbine at a pressure of 800 psia and a temperature of 1000°F . At the exit of the turbine, the pressure is 1 psia and the entropy is 0.2 Btu/lbm $^{\circ}\text{R}$ greater than the inlet. The inlet and exit velocities are essentially the same, and the process is adiabatic. What is the isentropic efficiency of the turbine? What is the mass rate of flow of steam (lbm/min) that is required to produce a power output of 20,000 hp?

(Ans. 80%; 1836 lbm/min)

- 9.4 In a Rankine cycle, steam enters the single-stage turbine at 7000 kPa and 450°C . Heat is rejected in the condenser at 30°C . If the pump efficiency is 90% and the turbine efficiency is 85%,

- a) calculate the pump work; (Ans. 7.81 kJ/kg)
- b) calculate the turbine work; (Ans. 1090 kJ/kg)
- c) calculate the heat rejected in the condenser; (Ans. 2071 kJ/kg)
- d) calculate the heat input to the boiler; (Ans. 3153 kJ/kg)
- e) calculate the entropy change across the turbine; (Ans. 0.631 kJ/kgK)
- f) calculate the thermal efficiency of the cycle. (Ans. 34.3%)

- 9.5 Superheated steam at 20 MPa and 550°C is expanded adiabatically through a set of nozzle vanes to a pressure of 12 MPa. The isentropic efficiency of the nozzles is 0.98. The velocity of the steam at entry to the nozzle vanes is negligible.
- Sketch the process on a T-s diagram.
 - Determine the kinetic energy of the steam at exit from the nozzle vanes. (Ans. 152 kJ/kg)
 - Determine the velocity (in m/s) of the steam at exit from the nozzles. (Ans. 551 m/s)
 - Determine the temperature of the steam at exit from the nozzles. (Ans. 462°C)
- 9.6 A simple steam power cycle uses solar energy for the heat input. Water in the cycle enters the pump as a saturated liquid at 120°F, and is pumped to 30 psia. It then evaporates in the boiler at this pressure, and enters the turbine as saturated vapour. At the turbine exhaust the conditions are 120°F and 6 per cent moisture. The flow rate is 300 lb/hr, and the pump is rated at 0.5 hp. Determine:
- the net power output; (Ans. 12.7 hp)
 - the energy-conversion efficiency; (Ans. 10%)
 - the square feet of solar collector needed if the collectors pick up 225 Btu/ft²hr. (Ans. 1433 ft²)
- 9.7 In certain regions of the oceans there is a temperature difference of about 20°C between the water near the surface and that at depths of about 500 m. It has been proposed that this can be utilized as a renewable energy resource to operate large electricity generating plants located out at sea.
- The generators could be driven by steam turbine units operating on a Rankine cycle, using water as the working fluid, with dry saturated steam entering the turbine at 24°C, 0.003 MPa, and condenser temperature and pressure of 4°C, 0.0008 MPa. For a unit designed to deliver 100 MW of power determine the following:
- The work extracted by the turbine from each kilogram of water flowing through the cycle, if the expansion through the turbine is isentropic. (Ans. 170.2 kJ/kg)

- b) The mass flow rate of working fluid assuming perfectly efficient generators (neglect the pump work).
(Ans. 587.5 kg/s)
- c) The thermal efficiency of the unit.
(Ans. 6.7%)
- d) The thermal efficiency of the unit if the turbine's isentropic efficiency were 75%.
(Ans. 5%)
- e) In what major respect(s) would the turbine for such a plant be unusual?

9.8 A refrigeration unit uses ozone friendly Refrigerant 134 working fluid. Dry saturated vapour at -20°C enters the compressor and is compressed adiabatically to 0.8 MPa and 55°C . Saturated liquid leaves the condenser and enters the expansion valve. The refrigeration unit has a capacity of 50 "tons".

(1 "ton" of refrigeration \equiv 200 BTU/min = 3.5 kW)

- a) Sketch the cycle on p-h and T-s diagrams and mark values of the pressures and temperatures at pertinent points on the diagram.
- b) Determine the mass flow rate of refrigerant fluid through the unit.
(Ans. 1.22 kg/s)
- c) Determine the coefficient of performance of the unit.
(Ans. 2.67)
- d) Determine the isentropic efficiency of the compressor.
(Ans. 0.70)

9.9 A steam power plant (see figure), incorporating a reciprocating steam engine, gave the following results during a test under steady conditions:

Boiler/superheater: Steam outlet conditions: pressure: 100 lbf/in^2 ; temperature: 400°F ;

Feed water: temperature: 130°F ; mass flow rate: 3.52 lbm/min .

Engine: Shaft power: 9 hp

Engine steam inlet conditions: as for boiler outlet.

Condenser: Cooling water: flow rate: 101 lbm/min ; temperature rise: 34°F

There are unmeasured heat transfers to the atmosphere from the exposed hot surfaces of the plant. Fluid velocities may be assumed to be negligible. Evaluate the following per unit mass of working fluid (H_2O):

- The heat transfer to the H_2O in the boiler. (Ans. 1130.1 Btu/lbm)
- The external work done by the H_2O in the engine. (Ans. 108.4 Btu/lbm)
- The heat transfer from the condensing steam in the condenser, assuming the heat transfer from the condenser casing to the atmosphere to be zero. (Ans. 976 Btu/lbm)
- The heat transfer to the atmosphere assuming the feed-pump work to be zero. (Ans. 46.1 Btu/lbm)
- The efficiency of the plant. (Ans. 9.6%)

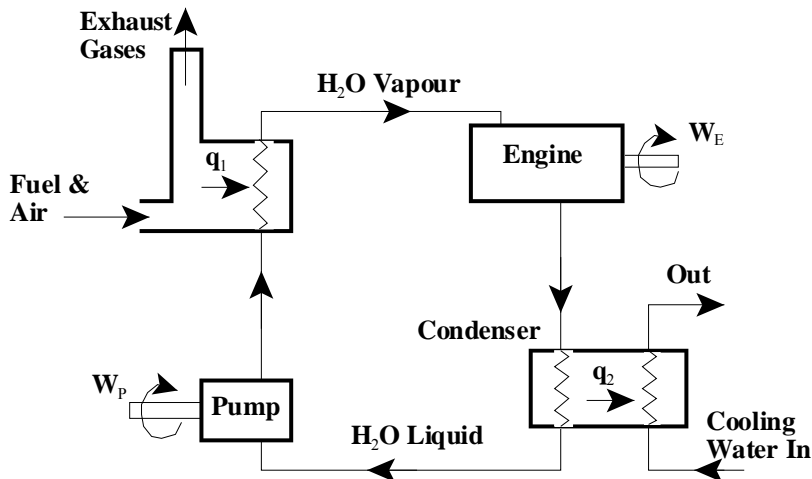

PA QUESTIONS 10 - Heat Transfer

10.1 It is desired to limit the heat loss through a boiler furnace wall to 2000 W/m^2 . The wall is composed of fire brick having a thermal conductivity of $1.15 \text{ W/m}^\circ\text{C}$.

a) If the inner surface temperature is 1100°C and the outer surface 370°C , what thickness should be used?

(0.42 m)

b) If the wall has 5 cm of insulation ($k = 0.09 \text{ W/m}^\circ\text{C}$) added to its outer surface and reduces the exposed surface temperature to 180°C , what will be the rate of heat loss through the wall per unit of area?

(999.4 W/m^2)

10.2 The composite wall of a furnace is made of 20 cm of fire-clay brick (burnt at 1330°C), 15 cm of fired diatomaceous earth brick, and an outer layer of common brick 10 cm thick. If the inside surface is at 1050°C and the outside surface is held at 150°C , find

a) the heat loss per unit area;

(Ans. 990 W/m^2)

b) the temperatures at the junction between the different layers of brick and;

(Ans. 865°C ; 294°C)

c) the temperature at a point 15 cm from the outer surface into the wall.

(Ans. 484°C)

Properties

k

Fire-clay (burnt at 1330°C)

$1.07 \text{ W/m}^\circ\text{C}$

Diatomaceous earth brick

$0.26 \text{ W/m}^\circ\text{C}$

Common brick

$0.69 \text{ W/m}^\circ\text{C}$

- 10.3 The flat wall of a furnace, 6 cm thick and composed of a material with $k = 2.5 \text{ W/mK}$, is maintained at 200°C on its inside face. The outside face is exposed to a convective heat loss to ambient air at 35°C through a surface heat transfer coefficient of $h = 50 \text{ W/m}^2\text{K}$. The outside face, which is gray with an emissivity $\epsilon = 0.8$, also exchanges radiant heat with the walls of a very large room in which the furnace is located. These black walls are at a temperature of 30°C . Find the temperature of the exposed surface of the furnace.

(Ans. 104°C)

- 10.4 A flat surface is covered with insulation with a thermal conductivity of 0.08 W/mK . The temperature at the interface between the surface and the insulation is 300°C . The outside insulation is exposed to air at 30°C , and the heat transfer coefficient for convection between the insulation and the air is $10 \text{ W/m}^2\text{K}$. Ignoring radiation, determine the minimum thickness of insulation, in m, such that the outside of the insulation is no hotter than 60°C at steady state.

(Ans. 0.064)

- 10.5 Find the indicated dimensionless parameters for the specified fluids and conditions.

Re_L , Nu_L and Pr are dimensionless parameters defined by $Re_L = \rho UL/\mu$; $Nu_L = hL/k$; $Pr = \mu C_p/k$. In the case of Re and Nu , the subscript refers to the length quantity, L , x or D .

- a) Find Re_x for: $U = 20 \text{ m/s}$
 $x = 0.6 \text{ m}$
 air at 25°C , 1 atm, $\mu = 18.6 \times 10^{-6} \text{ N-s/m}^2$
- b) Find Re_D for: $m = 0.5 \text{ kg/s}$
 $D = 10 \text{ cm}$
 water at 40°C , $\mu = 658 \times 10^{-6} \text{ N-s/m}^2$
- c) Find Nu_L for: $h = 10 \text{ W/m}^2\text{C}$
 $L = 1 \text{ m}$
 CO_2 at 50°C , 1 atm, $k = 0.017 \text{ W/m}^\circ\text{C}$
- d) Find Nu_x for: $h = 110 \text{ Btu/hr-ft}^2\text{F}$
 $x = 3 \text{ ft}$
 steam at 100 psia, 400°F , $k = 0.017 \text{ Btu/hr ft}^\circ\text{F}$
- e) Find Pr for: $\mu = 2.04 \times 10^{-5} \text{ kg/m-s}$
 $C_p = 0.958 \text{ kJ/kg}^\circ\text{C}$
 $k = 0.02631 \text{ W/m}^\circ\text{C}$

- 10.6 Water flows with a freestream velocity of $U = 1.5$ m/s at a freestream temperature of $T_f = 80^\circ\text{C}$ past a flat surface of total length $L = 10$ cm, which is maintained at a temperature of $T_s = 40^\circ\text{C}$. Using the analytical results for laminar boundary layer development in incompressible flow: i.e.

$$\frac{\delta}{x} = 5.0 \text{Re}_x^{-1/2} \quad (\mu = 4.71 \times 10^{-4} \text{ kg/m-s})$$

and

$$\frac{\delta_t}{\delta} = \text{Pr}^{-1/3} \quad (k = 0.654 \text{ W/m}^\circ\text{C})$$

- a) Find the thickness of the velocity boundary layer and the thermal layer at a location $x = 5$ cm from the leading edge.

$$(\text{Ans. } \delta = 0.0629 \text{ cm; } \delta_t = 0.0436 \text{ cm})$$

- b) Using the expressions for average heat flow to the plate, in the laminar flow regime, namely

$$Nu_L = \frac{\bar{h}L}{k} = 0.664 \text{Pr}^{1/3} \text{Re}_L^{1/2}$$

find, per metre of width of the plate, the heat flow to one side of the plate from the water.

$$(\text{Ans. } 14 \text{ kW})$$

- 10.7 Air at 90°F and atmospheric pressure flows with a velocity of 50 ft/sec past a flat surface which is at 70°F . Find the local heat transfer coefficient and heat flux at a location 2 ft from the leading edge. (Note: $Nu_x = 0.0296 \text{Re}_x^{0.8} \text{Pr}^{1/3}$ for this turbulent regime)

$$(\text{Ans. } 8.26 \text{ Btu/hr ft}^2\text{F; } 165.2 \text{ Btu/hr ft}^2 \text{ to plate})$$

At the film temperature:

C_p	=	0.24 Btu/lbm $^\circ\text{R}$
k	=	0.0155 Btu/hr ft $^\circ\text{F}$
μ	=	0.046 lbm/hr ft
ρ	=	0.073 lbm/ft 3

APPENDIX

Units

		Imperial	SI
Primary Units	Length	Foot (ft)	
	mass	pound mass (lbm) or slug (=32.174 lbm)	kilogram (kg)
	time	second (s)	second (s)
	temperature	°F or °R (°R = °F + 460)	°C or K (K = °C + 273)
Derived Units	force	pound force (lbf) (1 lbf = 1 slug ft/s ² = 32.174 lbm ft/s ²)	newton (N) (= kg m/s ²)
	pressure	lbf/in ² or lbf/ft ² (psf) (If absolute, psia, etc.)	pascal (Pa) (= N/m ²)
	work, energy	ft lbf or Btu (1 Btu = 778 ft lbf)	joule (J) (= Nm)
	power	ft lbf/s, Btu/s, or hp (1 hp = 550 ft lbf/s)	Watt (W) (= J/s)

Conversion factors

Length

1 ft	= 0.3048 m
1 m	= 3.2808 ft
1 in	= 2.54 cm
1 cm	= 0.3937 in

1 mi.	= 5280 ft
1 km	= 0.6214 mi.

Mass

1 lbm	= 0.453592 kg
1 kg	= 2.20462 lbm
1 slug	= 14.594 kg

1 slug	= 32.174 lbm
1 ton	= 2000 lbm
1 tonne	= 1000 kg

Pressure

1 psi	= 6.894757 kPa
1 Pa	= 145.04x10 ⁻⁶ psi

1 bar	= 100 kPa
1 atm	= 101.325 kPa
1 atm	= 14.696 psi
1 in. Hg	= 0.4912 psi
1 mm Hg	= 0.1333 kPa
1 in. Hg	= 3.387 kPa

Energy

1 Btu	= 1.055056 kJ
1 kJ	= 0.947817 Btu
1 lbf.ft	= 1.35582 J
1 J	= 0.73756 lbf.ft
1 cal	= 4.1840 J
1 IT cal	= 4.1868 J
1 Btu	= 778.169 lbf.ft

Volume

1 ft ³	= 0.028317 m ³
1 m ³	= 35.315 ft ³
1 in ³	= 16.387 cm ³
1 cm ³	= 0.061024 in ³

1 US gal	= 0.0037854 m ³ = 231 in ³
1 Imp gal	= 1.2009 US gal
1 L	= 0.001 m ³
1 L	= 0.0353 ft ³

Density

1 lbm/ft ³	= 16.018 kg/m ³
1 kg/m ³	= 0.062428 lbm/ft ³

Specific Volume

1 ft ³ /lbm	= 0.062428 m ³ /kg
1 m ³ /kg	= 16.018 ft ³ /lbm

Force

1 lbf	= 4.448222 N
1 N	= 0.224809 lbf
1 dyne	= 1x10 ⁻⁵ N

Specific Energy

1 Btu/lbm	= 2.326 kJ/kg
1 kJ/kg	= 0.42992 Btu/lbm
1 Btu/lbmol	= 2.326 kg/kmol
1 kJ/kmol	= 0.42992 Btu/lbmol

Energy Transfer Rate

1 Btu/s	= 1.055056 kW
1 kW	= 0.947817 Btu/s
1 hp	= 550 lbf.ft/s
1 hp	= 2545 Btu/hr
1 hp	= 0.7457 kW

Heat Transfer

$$1 \text{ BTU/hr ft}^2\text{F} = 5.678 \text{ W/m}^2 \text{ K}$$

$$1 \text{ BTU/hr ft}^2\text{F} = 1.7307 \text{ W/m}^2 \text{ K}$$

Specific Entropy, Specific Heat, Gas Constant

$$1 \text{ Btu/lbm}^\circ\text{R} = 4.1868 \text{ kJ/kg K}$$

$$1 \text{ kJ/kg.K} = 0.238846 \text{ Btu/lbm}^\circ\text{R}$$

$$1 \text{ Btu/lbmol}^\circ\text{R} = 4.1868 \text{ kJ/kg K}$$

$$1 \text{ kJ/kmol K} = 0.238846 \text{ Btu/lbmol}^\circ\text{R}$$

Velocity

$$1 \text{ ft/s} = 0.3048 \text{ m/s}$$

$$1 \text{ mph} = 1.467 \text{ ft/s}$$

$$1 \text{ mph} = 0.447 \text{ m/s}$$

Temperature

$$T(^{\circ}\text{C}) = (5/9) \times (T(^{\circ}\text{F}) - 32)$$

$$T(^{\circ}\text{F}) = (9/5) \times T(^{\circ}\text{C}) + 32$$

$$T(^{\circ}\text{C}) = T(\text{K}) - 273.15$$

$$T(^{\circ}\text{F}) = T(^{\circ}\text{R}) - 459.67$$

$$T(^{\circ}\text{R}) = 1.8 \times T(\text{K})$$

Some Physical Properties of Water, Air and Carbon Dioxide

Water at 20°C

$$\mu = 2.1 \times 10^{-5} \text{ lbf s/ft}^2 = 10^{-3} \text{ N s/m}^2$$

$$\rho = 62.3 \text{ lbf/ft}^3 = 998 \text{ kg/m}^3$$

$$c_p = 1 \text{ Btu/(lbfm } ^\circ\text{R)} = 4.187 \text{ kJ/(kg K)}$$

$$k = 0.346 \text{ BTU/(hr ft } ^\circ\text{F)} = 0.599 \text{ W/mK}$$

Air at 20°C and 101.325 kPa

$$\mu = 3.8 \times 10^{-7} \text{ lbf s/ft}^2 = 1.8 \times 10^{-5} \text{ N s/m}^2$$

$$\rho = 0.075 \text{ lbf/ft}^3 = 1.205 \text{ kg/m}^3$$

$$c_p = 0.24 \text{ Btu/(lbfm } ^\circ\text{R)} = 1.005 \text{ kJ/(kg K)}; c_p/c_v = 1.4$$

$$k = 0.0147 \text{ BTU/(hr ft } ^\circ\text{F)} = 0.0255 \text{ W/mK}$$

$$\text{gas constant, } R_{\text{air}} = 53.3 \text{ ft lbf/lbfm}^\circ\text{R} = 287 \text{ J/kg K}$$

Carbon Dioxide

$$\mu = 0.81 \mu_{\text{air}}$$

$$C_p = 0.205 \text{ BTU/lbfm}^\circ\text{R} = 0.855 \text{ kJ/kg K}$$

$$C_p/C_v = 1.30$$

$$k = 0.63 k_{\text{air}}$$

$$\text{gas constant} = 35.1 \text{ ft lbf/lbfm}^\circ\text{R} = 189 \text{ J/kg K}$$

Stefan-Boltzmann Constant

$$\sigma = 0.1714 \times 10^{-8} \text{ BTU/hr-ft}^2\text{ } ^\circ\text{R}^4$$

$$= 5.6703 \times 10^{-8} \text{ W/mK}^4$$