

# ITI1100Z

Professor: Qi Hao

## Assignment # 2

**Submission Deadline May 31, 2018 midnight (11h59 PM), Brightspace**

From the textbook Chapter 2 pages 69-71 in the 5<sup>th</sup> edition or pages 76-78 in the 6<sup>th</sup> edition, solve the following problems

**2.1(a)(b)(d), 2.4, 2.7(c)(d)(e), 2.9, 2.11, 2.13(c)(d)(e)(f), 2.14, 2.15, 2.17(b), 2.18, 2.25(b).**

2.1 (a)

Total 3 points
-------------------

x y z	$x + y + z$	$(x + y + z)'$	$x'$	$y'$	$z'$	$x' y' z'$
0 0 0	0	1	1	1	1	1
0 0 1	1	0	1	1	0	0
0 1 0	1	0	1	0	1	0
0 1 1	1	0	1	0	0	0
1 0 0	1	0	0	1	1	0
1 0 1	1	0	0	1	0	0
1 1 0	1	0	0	0	1	0
1 1 1	1	0	0	0	0	0

(b)

x y z	$x + yz$	$(x + y)$	$(x + z)$	$(x + y)(x + z)$
0 0 0	0	0	0	0
0 0 1	0	0	1	0
0 1 0	0	1	0	0
0 1 1	1	1	1	1
1 0 0	1	1	1	1
1 0 1	1	1	1	1
1 1 0	1	1	1	1
1 1 1	1	1	1	1

(d)

x y z	x	$y + z$	$x + (y + z)$	$(x + y)$	$(x + y) + z$
0 0 0	0	0	0	0	0
0 0 1	0	1	1	0	1
0 1 0	0	1	1	1	1
0 1 1	0	1	1	1	1
1 0 0	1	0	1	1	1
1 0 1	1	1	1	1	1
1 1 0	1	1	1	1	1
1 1 1	1	1	1	1	1

2.4

Total  
5 points

- (a)  $A'C' + ABC + AC' = C' + ABC = (C' + C')(C' + AB) = AB + C'$
- (b)  $(x'y' + z)' + z + xy + wz = (x'y')'z' + z + xy + wz = [(x + y)z' + z] + xy + wz = (z + z')(z + x + y) + xy + wz = z + wz + x + xy + y = z(1 + w) + x(1 + y) + y = x + y + z$
- (c)  $A'B(D' + C'D) + B(A + A'CD) = B(A'D' + A'C'D + A + A'CD) = B(A'D' + A + A'D(C + C')) = B(A + A'(D' + D)) = B(A + A') = B$
- (d)  $(A' + C)(A' + C')(A + B + C'D) = (A' + CC')(A + B + C'D) = A'(A + B + C'D) = AA' + A'B + A'C'D = A'(B + C'D)$
- (e)  $ABC'D + A'BD + ABCD = AB(C + C')D + A'BD = ABD + A'BD = BD$

2.7

Total  
6 points

(c)

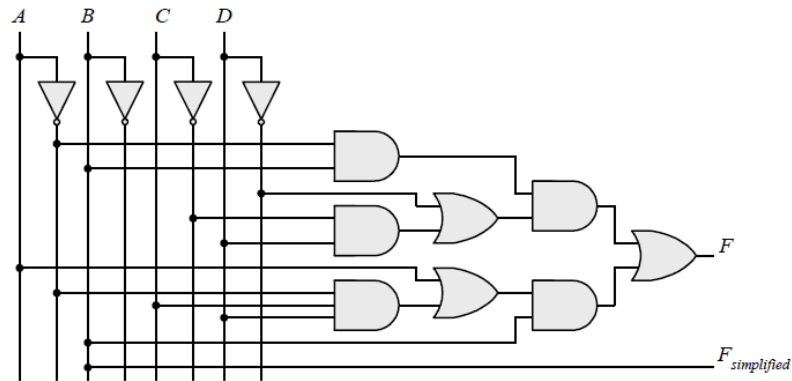

(d)

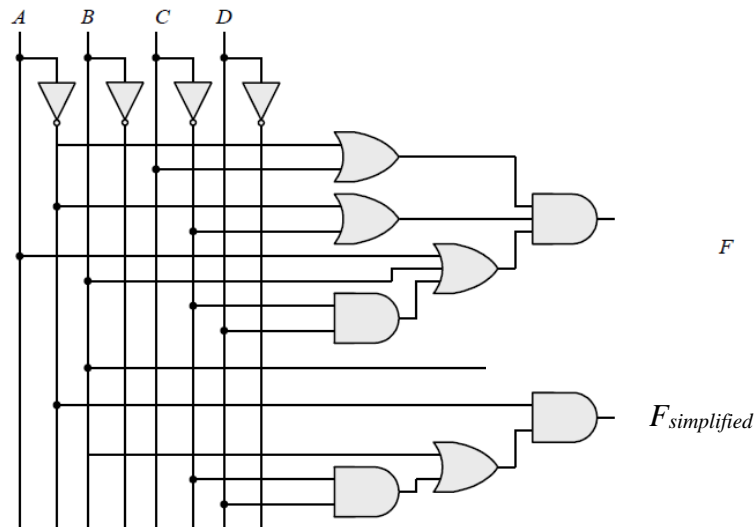

(e)

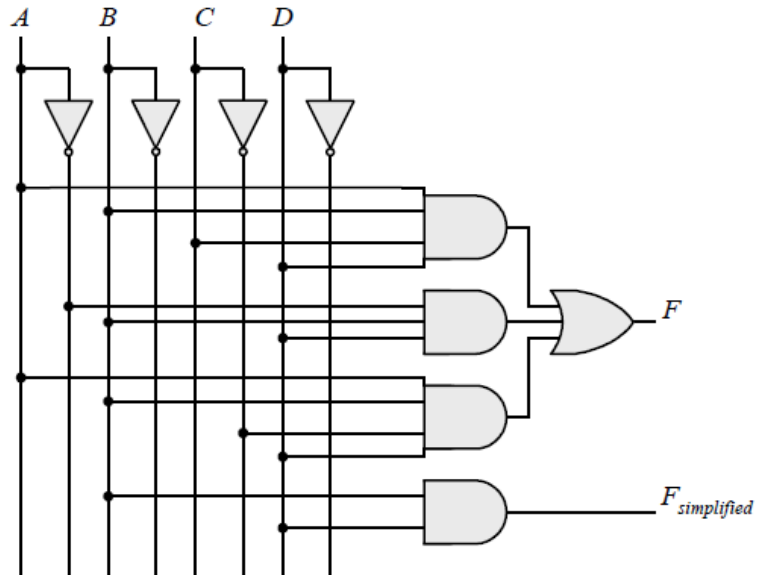

.Digital Design With An Introduction to the Verilog HDL, VHDL, and SystemVerilog, Sixth Edition – Solution Manual.  
M. Mano. M.D. Ciletti, Copyright 2017 .

All rights reserved.

2.9

Total  
3 points

(a)  $F' = (xy' + x'y)' = (xy')'(x'y)' = (x' + y)(x + y') = xy + x'y'$

(b)  $F' = [(a + c)(a + b')(a' + b + c')] = (a + c)' + (a + b')' + (a' + b + c)'$   
 $= a'c' + a'b + ab'c$

(c)  $F' = [z + z'(v'w + xy)]' = z'[z'(v'w + xy)]' = z'[z'v'w + xyz']'$   
 $= z'[(z'v'w)'(xyz')'] = z'[(z + v + w') + (x' + y' + z)]$   
 $= z'z + z'v + z'w' + z'x' + z'y' + z'z = z'(v + w' + x' + y')$

(c) **Error. Correction:**

$(z + z'(v'w + xy))' = z'[z'(v'w + xy)]' = z'[z'v'w + xyz']' =$   
 $z'((z'v'w)'(xyz')') = z'((z + v + w')(x' + y' + z)) =$   
 $z'(z + (v + w')(x' + y')) = z'(v + w')(x' + y')$

2.11

(a)  $F(x, y, z) = \Sigma(1, 4, 5, 6, 7)$

Total  
2 points

(b)  $F(a, b, c) = \Sigma(0, 2, 3, 7)$

$F = xy + xy' + y'z$		$F = bc + a'c'$	
x y z	F	a b c	F
0 0 0	0	0 0 0	1
0 0 1	1	0 0 1	0
0 1 0	0	0 1 0	1
0 1 1	0	0 1 1	1
1 0 0	1	1 0 0	0
1 0 1	1	1 0 1	0
1 1 0	1	1 1 0	0
1 1 1	1	1 1 1	1

2.13

Total  
4 points

(c)

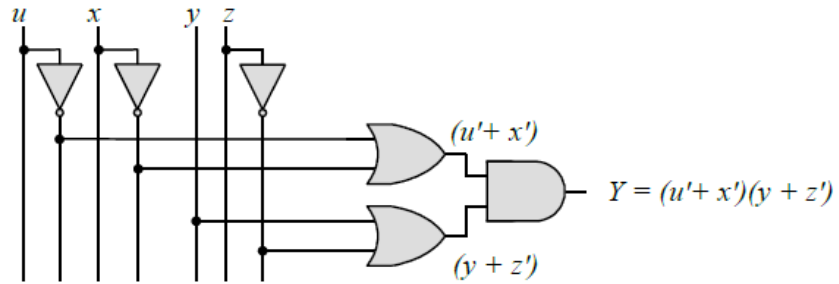

(d)

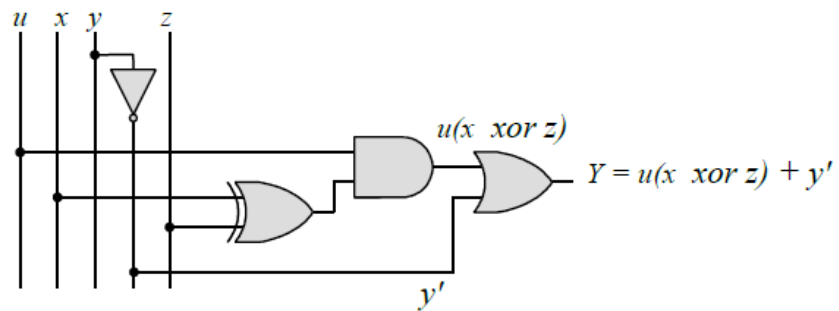

(e)

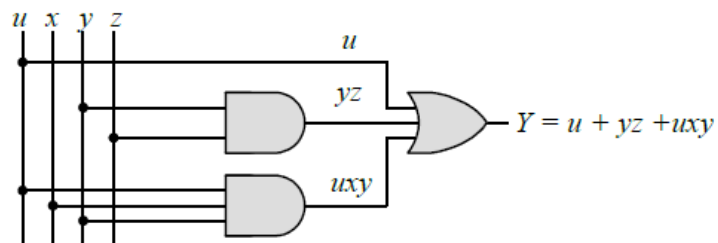

(f)

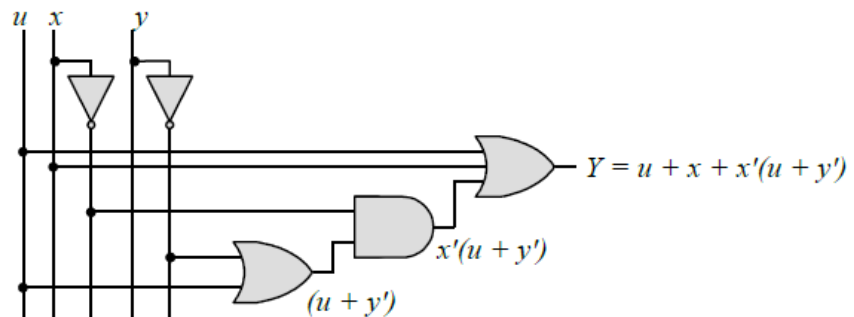

2.14 (a)

Total  
6.5 points

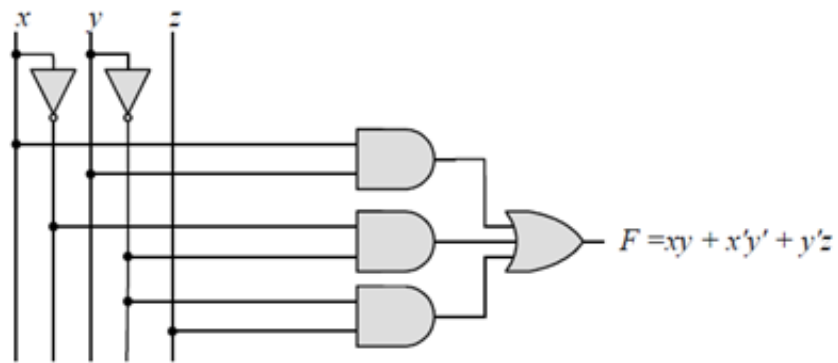

(b)

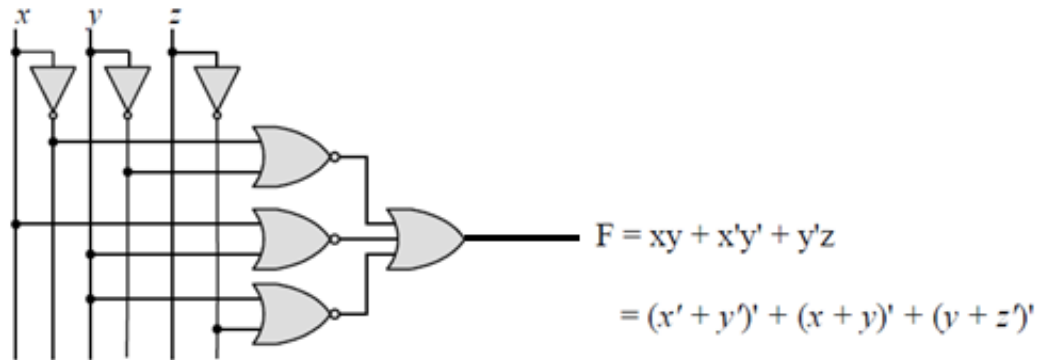

**Correction for (b): NOR gate should be replaced by an OR gate plus an inverter gate.**

(c)

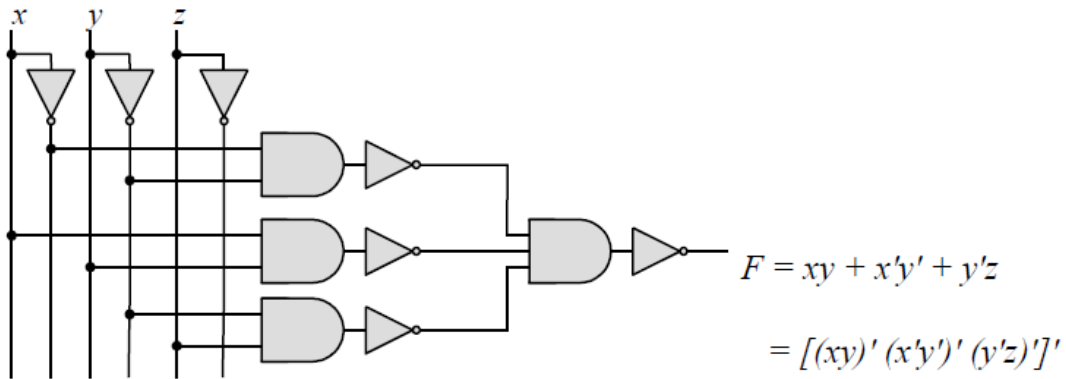

(d)

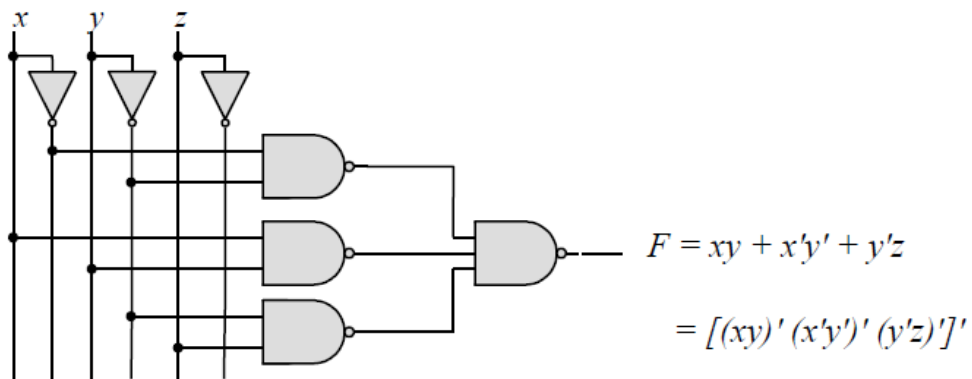

(e)

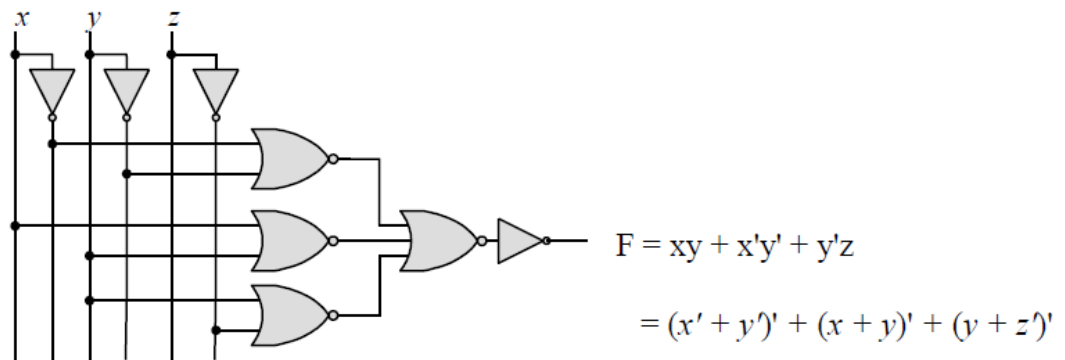

2.15 (a)  $T_1 = A'B'C' + A'B'C + A'BC' = A'B'(C' + C) + A'C'(B' + B) = A'B' + A'C' = A'(B' + C')$

Total  
3 points

(b)  $T_2 = T_1' = A'BC + AB'C' + AB'C + ABC' + ABC$   
 $= BC(A' + A) + AB'(C' + C) + AB(C' + C)$   
 $= BC + AB' + AB = BC + A(B' + B) = A + BC$

$\Sigma(3, 5, 6, 7) = \Pi(0, 1, 2, 4)$

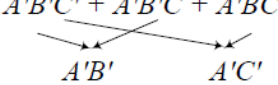
$T_1 = A'B'C' + A'B'C + A'BC'$   

$T_1 = A'B' A'C' = A'(B' + C')$

$T_2 = A'BC + AB'C' + AB'C + ABC' + ABC$   

$T_2 = AC' + BC + AC = A + BC$

2.17 (b)  $(cd + b'c + bd')(b + d) = bcd + bd' + cd + b'cd = cd + bd'$   
 $= \Sigma(3, 4, 7, 11, 12, 14, 15)$   
 $= \Pi(0, 1, 2, 5, 6, 8, 9, 10, 13)$

Total  
1.5 points

a	b	c	d	F
0	0	0	0	0
0	0	0	1	0
0	0	1	0	0
0	0	1	1	1
0	1	0	0	1
0	1	0	1	0
0	1	1	0	0
0	1	1	1	1
1	0	0	0	0
1	0	0	1	0
1	0	1	0	0
1	0	1	1	1
1	1	0	0	1
1	1	0	1	0
1	1	1	0	1
1	1	1	1	1

2.18 (a)

Total  
5 points

wx y z	F
00 0 0	0
00 0 1	1
00 1 0	0
00 1 1	0
01 0 0	0
01 0 1	1
01 1 0	1
01 1 1	1
10 0 0	0
10 0 1	1
10 1 0	1
10 1 1	1
11 0 0	0
11 0 1	1
11 1 0	1
11 1 1	1

$$F = xy'z + x'y'z + w'xy + wx'y + wxy$$

$$F = \Sigma(1, 5, 6, 7, 9, 10, 11, 13, 14, 15)$$

(b)

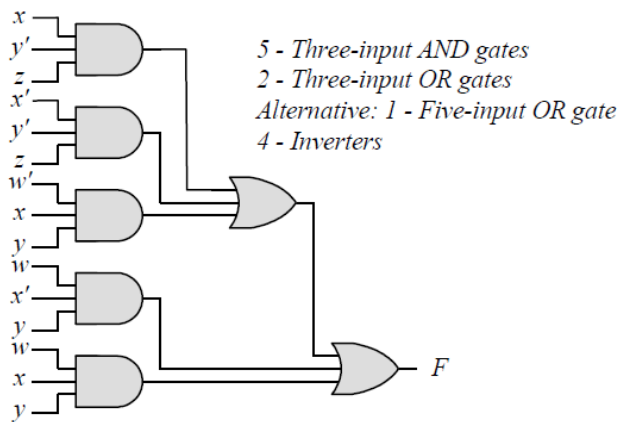

(c)  $F = xy'z + x'y'z + w'xy + wx'y + wxy = y'z + xy + wy = y'z + y(w + x)$

(d)  $F = y'z + yw + yx = \Sigma(1, 5, 9, 13, 10, 11, 13, 15, 6, 7, 14, 15)$   
 $= \Sigma(1, 5, 6, 7, 9, 10, 11, 13, 14, 15)$

(e)

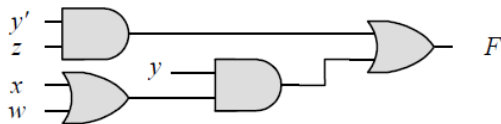

1 - Inverter, 2 - Two-input AND gates, 2 - Two-input OR gates

2.25

Total  
1 point

(b)  $(x \oplus y) = xy' + x'y = y \oplus x = yx' + y'x$  Commutative

$(x \oplus y) \oplus z = \sum(1, 2, 4, 7) = x \oplus (y \oplus z)$  Associative

*.Digital Design With An Introduction to the Verilog HDL, VHDL, and SystemVerilog, Sixth Edition – Solution Manual.*  
M. Mano. M.D. Ciletti, Copyright 2017 .

All rights reserved.