

CVG2140 – Solutions to Assignment No. 4 (Axially loaded members)

Problem 1. A solid brass ($E = 100 \text{ GPa}$) axial member is loaded and supported as shown in Figure 1. Segment (1) and (2) each have a diameter of 25 mm, and segment (3) has a diameter of 14 mm. Determine

- the deformation of segment (2)
- the deflection of joint D with respect to the fixed support at A
- the maximum normal stress in the entire axial member

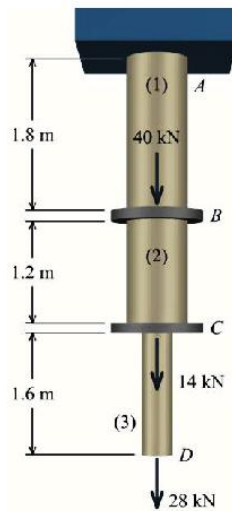

(a) Draw a FBD that cuts through segment (2) and includes the free end of the axial member. From this FBD, the sum of forces in the vertical direction reveals the internal force in the segment:

$$\Sigma F_y = F_2 - 14 \text{ kN} - 28 \text{ kN} = 0 \quad \longrightarrow \quad F_2 = 42 \text{ kN (T)}$$

The cross-sectional area of the 25-mm-diameter segment is

$$A_2 = \frac{\pi}{4} * (25 \text{ mm})^2 = 490.87 \text{ mm}^2$$

The deformation in segment (2) is thus

$$\delta_2 = \frac{F_2 L_2}{A_2 E_2} = \frac{42000 \text{ N} * 1200 \text{ mm}}{490.87 \text{ mm}^2 * 100000 \text{ N/mm}^2} = 1.027 \text{ mm}$$

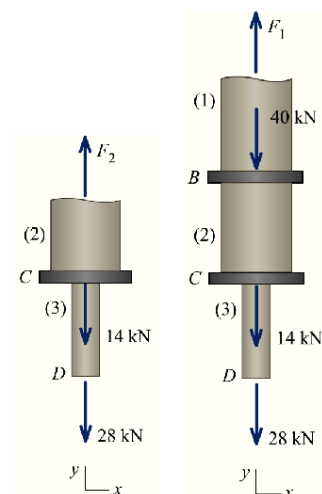

(b) The internal forces in segments (1) and (3) must be determined at the outset. From a FBD that cuts through segment (1) and includes the free end of the axial member:

$$\Sigma F_y = F_1 - 40 \text{ kN} - 14 \text{ kN} - 28 \text{ kN} = 0 \quad \longrightarrow \quad F_1 = 82 \text{ kN (T)}$$

The deformation in segment (1) can be computed as

$$\delta_1 = \frac{F_1 L_1}{A_1 E_1} = \frac{82000 \text{ N} \cdot 1800 \text{ mm}}{490.87 \text{ mm}^2 \cdot 100000 \text{ N/mm}^2} = 3.006 \text{ mm}$$

Similarly, consider a FBD that cuts through segment (3) and includes the free end of the axial member:

$$\Sigma F_y = F_3 - 28 \text{ kN} = 0 \quad F_3 = 28 \text{ kN (T)}$$

The cross-sectional area of the 14-mm-diameter segment is

$$A_3 = \frac{\pi}{4} \cdot (14 \text{ mm})^2 = 153.94 \text{ mm}^2$$

The deformation in segment (3) can be computed as

$$\delta_3 = \frac{F_3 L_3}{A_3 E_3} = \frac{28000 \text{ N} \cdot 1600 \text{ mm}}{153.94 \text{ mm}^2 \cdot 100000 \text{ N/mm}^2} = 2.81 \text{ mm}$$

The deflection of joint *D* with respect to the fixed support at *A* is found from the sum of the three segment deformations:

$$u_D = \delta_1 + \delta_2 + \delta_3 = 6.94 \text{ mm}$$

(c) Since segments (1) and (2) have the same cross-sectional area, the maximum normal stress in these two segments occurs where the axial force is greater; that is, in segment (1):

$$\sigma_1 = \frac{F_1}{A_1} = \frac{82000}{490.87} = 167.05 \text{ MPa (T)}$$

The normal stress in segment (3) is

$$\sigma_3 = \frac{F_3}{A_3} = \frac{28000}{153.94} = 181.9 \text{ MPa (T)}$$

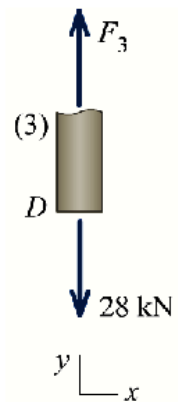

Therefore, the maximum normal stress in the axial member occurs in segment (3):

$$\sigma_{max} = 181.9 \text{ MPa (T)}$$

Problem 2. The load is supported by the four 304 stainless steel wires that are connected to the rigid members AB and DC. Determine the vertical displacement of the 500-lb load if the members were originally horizontal when the load was applied. Each wire has a cross-sectional area of 0.025 in^2 .

Internal Forces in the wires:

FBD (b)

$$\begin{aligned} \curvearrowright +\Sigma M_A = 0; & \quad F_{BC}(4) - 500(3) = 0 \\ \uparrow F_{BC} = 375.0 \text{ lb} \\ +\Sigma F_y = 0; & \quad F_{AH} + 375.0 - 500 = 0 \\ & \quad F_{AH} = 125.0 \text{ lb} \end{aligned}$$

FBD (a)

$$\begin{aligned} \curvearrowright +\Sigma M_D = 0; & \quad F_{CF}(3) - 125.0(1) = 0 \quad F_{CF} = \\ \uparrow 41.67 \text{ lb} \\ +\Sigma F_y = 0; & \quad F_{DE} + 41.67 - 125.0 = 0 \quad F_{DE} = \\ 83.33 \text{ lb} \end{aligned}$$

Displacement:

$$\delta_D = \frac{F_{DE} \cdot L_{DE}}{A_{DE} \cdot E} = \frac{83.33 \cdot (3) \cdot (12)}{0.025 \cdot (28.0) \cdot (10)^6} = 0.0042857 \text{ in.}$$

$$\delta_C = \frac{F_{CF} \cdot L_{CF}}{A_{CF} \cdot E} = \frac{41.67 \cdot (3) \cdot (12)}{0.025 \cdot (28.0) \cdot (10)^6} = 0.0021429 \text{ in.}$$

$$\frac{\delta'_H}{2} = \frac{0.0021429}{3} = 0.0014286 \text{ in.}$$

$$\delta_H = 0.0014286 + 0.0021429 = 0.0035714 \text{ in.}$$

$$\delta_{A/H} = \frac{F_{AH} \cdot L_{AH}}{A_{AH} \cdot E} = \frac{125 \cdot (1.8) \cdot (12)}{0.025 \cdot (28.0) \cdot (10)^6} = 0.0038571 \text{ in.}$$

$$\delta_A = \delta_H + \delta_{A/H} = 0.0035714 + 0.0038571 = 0.0074286 \text{ in.}$$

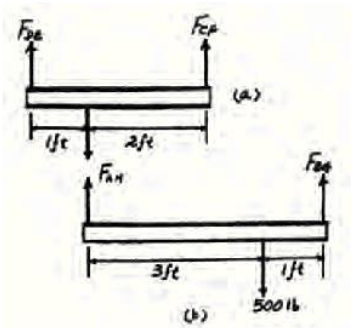
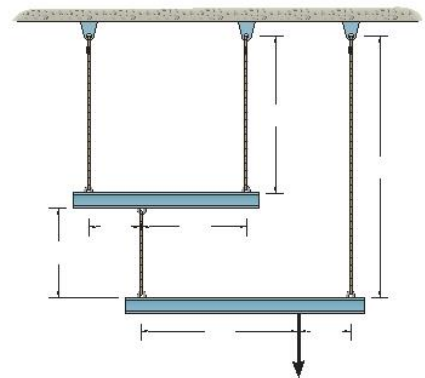

$$\delta_B = \frac{F_{BG} * L_{BG}}{A_{BG} * E} = \frac{375 * (5) * (12)}{0.025 * (28.0) * (10)^6} = 0.0321428 \text{ in.}$$

$$\frac{\delta'_l}{3} = \frac{0.0247143}{4} = 0.0185357 \text{ in.}$$

$$\delta_1 = 0.0074286 + 0.0185357 = 0.0260 \text{ in.}$$

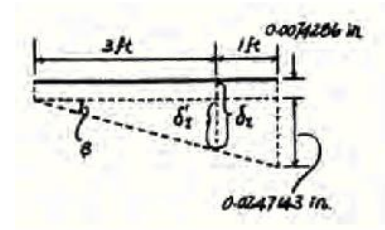

Problem 3. Two identical steel [$E = 200 \text{ GPa}$] pipes, each with a cross-sectional area of $1,475 \text{ mm}^2$, are attached to unyielding supports at the top and bottom, as shown in Figure 3. At flange B, a concentrated downward load of 120 kN is applied. Determine the normal stresses in the upper and lower pipes.

(a) **Equilibrium:** Consider a FBD of flange B.

Sum forces in the vertical direction to obtain:

$$\Sigma F_y = F_1 - F_2 - 120 \text{ kN} = 0 \quad (\text{a})$$

Geometry of Deformations:

$$\delta_1 + \delta_2 = 0 \quad (\text{b})$$

Force-Deformation Relationships:

$$\delta_1 = \frac{F_1 * L_1}{A_1 * E_1} \quad \delta_2 = \frac{F_2 * L_2}{A_2 * E_2} \quad (\text{c})$$

Compatibility Equation: Substitute Eqs. (c) into Eq. (b) to derive the compatibility equation:

$$\frac{F_1 * L_1}{A_1 * E_1} + \frac{F_2 * L_2}{A_2 * E_2} = 0 \quad (\text{d})$$

Solve the Equations: Solve Eq. (d) for F_2 :

$$F_2 = - F_1 * \frac{L_1}{A_1 * E_1} * \frac{A_2 * E_2}{L_2} = F_1 * \frac{L_1}{L_2} * \frac{A_2}{A_1} * \frac{E_2}{E_1} \quad (\text{e})$$

and substitute this expression into Eq. (a) to determine F_1 :

$$\Sigma F_y = F_1 - F_2 = F_1 - \left(F_1 * \frac{L_1}{L_2} * \frac{A_2}{A_1} * \frac{E_2}{E_1} \right) = F_1 \left(1 + \frac{L_1}{L_2} * \frac{A_2}{A_1} * \frac{E_2}{E_1} \right) = 120 \text{ kN} \quad (\text{f})$$

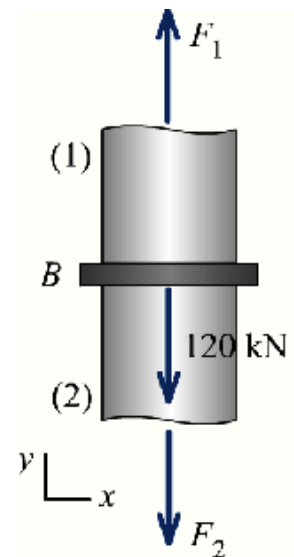
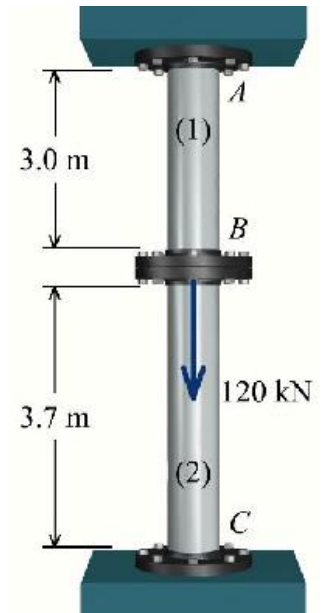

Notice that $A_1 = A_2$ and $E_1 = E_2$ for this structure. Therefore, F_1 can be computed as:

$$F_1 = \frac{120 \text{ KN}}{\left(1 + \frac{L_1}{L_2} * \frac{A_2}{A_1} * \frac{E_2}{E_1}\right)} = \frac{120 \text{ KN}}{\left(1 + \frac{3.0 \text{ m}}{3.7 \text{ m}}\right)} = \frac{120 \text{ KN}}{1.81} = 66.268$$

and from Eq. (e), F_2 has a value of

$$F_2 = -F_1 * \frac{L_1}{L_2} * \frac{A_2}{A_1} * \frac{E_2}{E_1} = -(66.268 \text{ KN}) * \frac{3.0 \text{ m}}{3.7 \text{ m}} = -53.73 \text{ KN}$$

Normal Stresses: The normal stresses in each axial member can now be calculated:

$$\sigma_1 = \frac{F_1}{A_1} = \frac{66.268}{1475} = 44.9 \text{ MPa (T)}$$

$$\sigma_2 = \frac{F_2}{A_2} = \frac{-53.73}{1475} = -36.43 \text{ MPa (T)} = 36.43 \text{ MPa (C)}$$

(b) The deflection of flange B is equal to the deformation (i.e., contraction in this instance) of member (2):

$$u_B = \delta_2 = \frac{F_2 * L_2}{A_2 * E_2} = \frac{-53.73 * 3700}{1475 * 200000} = -0.674 \text{ mm} = 0.674 \text{ mm} \downarrow$$

Problem 4. The concrete [$E = 29 \text{ GPa}$] pier shown in Figure 4 is reinforced using four steel [$E = 200 \text{ GPa}$] reinforcing rods, each having a diameter of 19 mm. If the pier is subjected to an axial load of 670 kN, determine:

- (a) the normal stress in the concrete and in the steel reinforcing rods.
- (b) the shortening of the pier.

(a) Equilibrium: Consider a FBD of the pier, cut around the upper end.

The concrete will be designated member (1) and the reinforcing steel bars

will be designated member (2). Sum forces in the vertical direction to obtain:

$$\Sigma F_y = -F_1 - F_2 - 670 \text{ kN} = 0 \quad (a)$$

Geometry of Deformations:

$$\delta_1 = \delta_2 \quad (b)$$

Force-Deformation Relationships:

$$\delta_1 = \frac{F_1 * L_1}{A_1 * E_1} \quad \delta_2 = \frac{F_2 * L_2}{A_2 * E_2} \quad (c)$$

Compatibility Equation: Substitute Eqs. (c) into Eq. (b) to derive the compatibility equation:

$$\frac{F_1 * L_1}{A_1 * E_1} = \frac{F_2 * L_2}{A_2 * E_2} \quad (d)$$

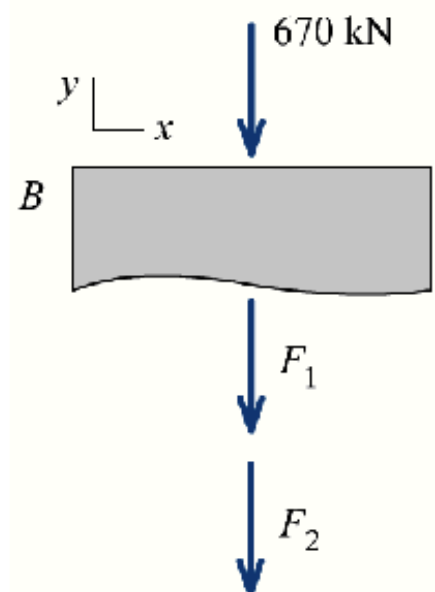
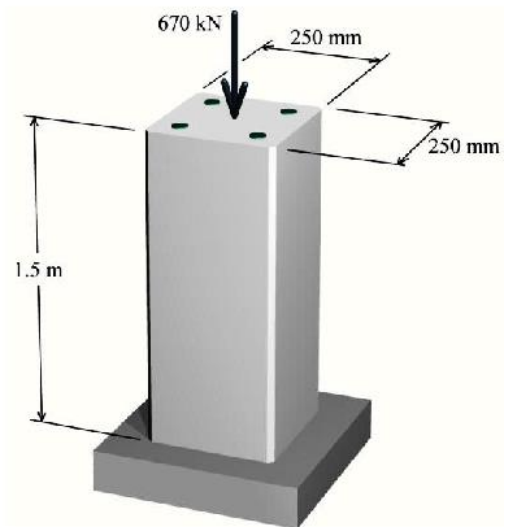

Solve the Equations: Solve Eq. (d) for F_2 :

$$F_2 = F_1 * \frac{L_1}{A_1 * E_1} * \frac{A_2 * E_2}{L_2} = F_1 * \frac{L_1}{L_2} * \frac{A_2}{A_1} * \frac{E_2}{E_1} \quad (e)$$

and substitute this expression into Eq. (a) to determine F_1 :

$$\begin{aligned} \Sigma F_y = -F_1 - F_2 &= -F_1 - \left(F_1 * \frac{L_1}{L_2} * \frac{A_2}{A_1} * \frac{E_2}{E_1} \right) = \\ -F_1 \left(1 + \frac{L_1}{L_2} * \frac{A_2}{A_1} * \frac{E_2}{E_1} \right) &= 670 \text{ KN} \quad (f) \end{aligned}$$

Since $L_1 = L_2$, the term $L_1/L_2 = 1$ can be eliminated and Eq. (f) simplified to

$$F_1 \left(1 + \frac{A_2}{A_1} * \frac{E_2}{E_1} \right) = -670 \text{ KN}$$

The gross cross-sectional area of the pier is $(250 \text{ mm})^2 = 62,500 \text{ mm}^2$; however, the reinforcing bars take up a portion of this area. The cross-sectional area of four 19-mm-diameter reinforcing bars is

$$A_2 = (4 \text{ bars}) * \frac{\pi}{4} * (19 \text{ mm})^2 = 1134.115 \text{ mm}^2$$

and thus the area of the concrete is

$$A_1 = 62500 \text{ mm}^2 - 1134.115 \text{ mm}^2 = 61365.885 \text{ mm}^2$$

F_1 can now be computed as:

$$F_1 \left(1 + \frac{1134.115}{61365.885} * \frac{200 \text{ Gpa}}{29 \text{ Gpa}} \right) = -670 \text{ KN} \longrightarrow F_1 = 594.258 \text{ KN}$$

and from Eq. (a), F_2 has a value of

$$F_2 = -F_1 - 670 \text{ KN} = -(-594.248) - 670 = -75.742 \text{ KN}$$

Normal Stresses: The normal stresses in each axial member can now be calculated. In the concrete, the normal stress is:

$$\sigma_1 = \frac{F_1}{A_1} = \frac{-594.248}{61365.885} = -9.68 \text{ MPa (T)} = 9.68 \text{ MPa (C)}$$

and the normal stress in the reinforcing bars is

$$\sigma_2 = \frac{F_2}{A_2} = \frac{-75742}{1134.115} = -66.8 \text{ MPa (T)} = 66.8 \text{ MPa (C)}$$

(b) The shortening of the 1.5-m-long pier is equal to the deformation (i.e., contraction in this instance) of member (1) or member (2):

$$u = \delta_1 = \frac{F_1 * L_1}{A_1 * E_1} = \frac{-594.258 * 1500}{61365.885 * 29000} = -0.501 \text{ mm} = 0.501 \downarrow$$