

Mid-term Exam
MCG 3340, Fluid Mechanics I
 November 9th, 2015
 1:00-2:20

Closed-book, non-programmable calculators only.

Name: Solutions

Student number: _____

Question	Possible	Result
1	10	
2	10	
3	10	
Total	30	

$$\vec{\nabla} p = \rho \vec{g} - \rho \vec{a}$$

$$d\vec{F} = -p \hat{n} dA$$

$$d\vec{M} = \vec{r}_e \times d\vec{F}$$

$$0 = \iiint_{C.V.} \rho dV + \iint_S \rho \vec{v} \cdot \hat{n} dS$$

$$\sum \vec{F} = \iiint_{C.V.} \rho \vec{v} dV + \iint_S \rho \vec{v} \vec{v} \cdot \hat{n} dS$$

$$\frac{p}{\rho} + gz + \frac{V^2}{2} = \text{constant}$$

$$\frac{k}{k-1} \frac{p}{\rho} + gz + \frac{V^2}{2} = \text{constant}$$

Name: _____

1) For low-speed flows, gases can often be assumed to be incompressible. Consider an airflow with a velocity of 50 km/h at atmospheric pressure (101 325 Pa).

- What is the stagnation pressure, $(p_0)_{\text{incompressible}}$, if the air is assumed to be incompressible?
- What is the stagnation pressure, $(p_0)_{\text{compressible}}$, if compressibility effects are taken into account?
- What is the percent error from assuming incompressibility? Percent error is defined as

$$\text{percent error} = \left| \frac{(p_0)_{\text{incompressible}} - (p_0)_{\text{compressible}}}{(p_0)_{\text{compressible}}} \right| \times 100$$

Repeat the above calculation for flow speeds of 250 km/h and 500 km/h.

Properties of air: $\rho = 1.225 \text{ kg/m}^3$, $k = 1.4$

Incompressible : $\frac{p}{\rho} + gz + \frac{V^2}{2} = \frac{p_0}{\rho_0} + gz_0 + \frac{V_0^2}{2} \Rightarrow \boxed{p_0 = p + \frac{\rho V^2}{2}}$

Compressible: $\frac{k}{k-1} \frac{p}{\rho} + gz + \frac{V^2}{2} = \frac{k}{k-1} \frac{p_0}{\rho_0} + gz_0 + \frac{V_0^2}{2}$

$$\frac{p_0}{\rho_0} = \frac{p}{\rho} + \frac{k-1}{k} \frac{V^2}{2} \Rightarrow \frac{p_0}{\rho_0} \frac{\rho}{p} = 1 + \frac{k-1}{k} \frac{\rho}{p} \frac{V^2}{2}$$

$$\frac{p}{\rho^k} = \frac{p_0}{\rho_0^k} \Rightarrow \rho_0 = \left(\frac{p_0}{p} \right)^{\frac{1}{k}} \rho$$

$$\frac{p_0}{\rho} \left(\frac{p}{p_0} \right)^{\frac{1}{k}} \frac{\rho}{p} = 1 + \frac{k-1}{k} \frac{\rho}{p} \frac{V^2}{2} \Rightarrow \boxed{p_0 = p \left[1 + \frac{k-1}{k} \frac{\rho}{p} \frac{V^2}{2} \right]^{\frac{k}{k-1}}}$$

50 km/h = 13.9 m/s

250 km/h = 69.4 m/s

500 km/h = 138.9 m/s

a) 101 443.25 Pa

a) 104 278.8 Pa

a) 113 140.2 Pa

b) 101 443.20 Pa

b) 104 309.7 Pa

b) 113 640.4 Pa

c) $4.9 \times 10^{-5} \%$

c) 0.03%

c) 0.44%

2) Water flows through a nozzle that contracts from a diameter of 10 cm to 2 cm. The fluid leaves the nozzle at atmospheric pressure with a velocity of 25 m/s.

- What is the fluid velocity at the entrance to the nozzle?
- What is the pressure at the entrance to the nozzle?
- What force is needed to keep the nozzle in place?

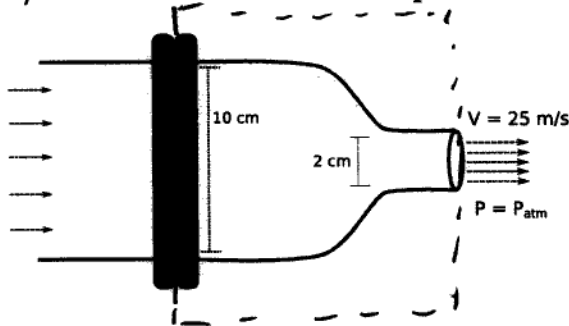

$$0 = \frac{\partial}{\partial t} \iiint_{V.C.} \rho \vec{v} dV + \iint_S \rho \vec{v} \cdot \vec{n} dS$$

$$0 = -V_1 S_1 + V_2 S_2$$

$$V_1 = \frac{V_2 S_2}{S_1} = \frac{(25 \text{ m/s}) \left(\frac{\pi (0.02 \text{ m})^2}{4} \right)}{\frac{\pi (0.1 \text{ m})^2}{4}} = \boxed{1 \text{ m/s}}$$

$$\text{Bernoulli: } \frac{P_1}{\rho} + \frac{1}{2} V_1^2 = \frac{P_{\text{atm}}}{\rho} + \frac{1}{2} V_2^2$$

$$\underbrace{(P_1 - P_{\text{atm}})}_{P_{\text{rel}}} = \frac{\rho}{2} (V_2^2 - V_1^2) \Rightarrow P_{\text{rel}} = \frac{1000 \text{ kg/m}^3}{2} \left((25 \text{ m/s})^2 - (1 \text{ m/s})^2 \right)$$

$$= \boxed{312 \text{ kPa}}$$

$$\sum \vec{F} = \frac{\partial}{\partial t} \iiint_{V.C.} \rho \vec{v} dV + \iint_S \rho \vec{v} \cdot \vec{n} dS$$

$$x \text{ dir: } F_a + F_p = -\rho V_1^2 S_1 + \rho V_2^2 S_2 \quad F_p = P_{\text{rel}} S_1$$

$$F_a = \rho [V_2^2 S_2 - V_1^2 S_1] - P_{\text{rel}} S_1$$

$$= 1000 \text{ kg/m}^3 \left\{ (25 \text{ m/s})^2 \left[\frac{\pi (0.02 \text{ m})^2}{4} \right] - (1 \text{ m/s})^2 \left[\frac{\pi (0.1 \text{ m})^2}{4} \right] \right\} - 312000 \text{ Pa} \left[\frac{\pi (0.1 \text{ m})^2}{4} \right] = \boxed{-2262 \text{ N} \uparrow}$$

3) A 200 kg boat takes water at atmospheric pressure through a horizontal pipe in front and produces a jet at an angle of 60° . The diameter of the entrance is very large and the water velocity here can be neglected in the momentum balance. The exit diameter is 10 cm and the jet has a velocity of 30 m/s. The boat is held in place by a cable.

a) What is the tension in the cable?

b) How much water must the boat displace to stay afloat?

$$\sum \vec{F} = \frac{\partial}{\partial t} \iiint_{CV} \rho \vec{v} dV + \iint_S \rho \vec{v} \vec{v} \cdot \hat{n} dS$$

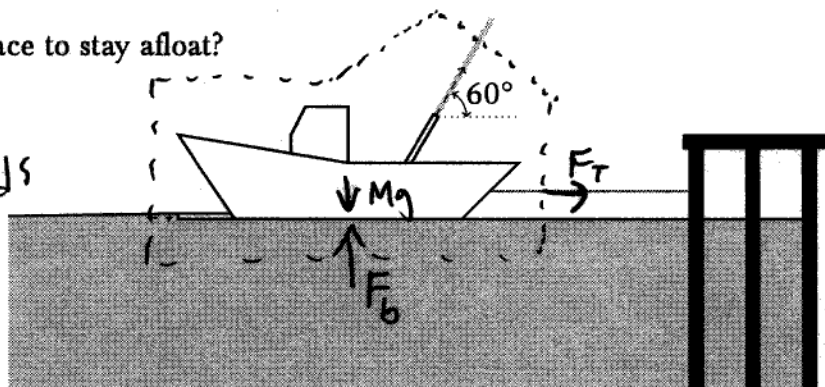

$$a) \sum F_x = F_T = \rho v_x S (\vec{v} \cdot \hat{n}) = \rho v_x S |v| = \rho |v|^2 S \cos 60$$

$$= (1000 \text{ kg/m}^3) (30 \text{ m/s})^2 \left[\frac{\pi (0.1 \text{ m})^2}{4} \right] \left(\frac{1}{2} \right) = \boxed{3535 \text{ N}}$$

$$b) \sum F_y = \rho v_y S (\vec{v} \cdot \hat{n}) = \rho |v|^2 S \sin 60$$

$$F_g + F_b = \rho |v|^2 S \sin 60$$

$$(buoyancy) F_b = (1000 \text{ kg/m}^3) (30 \text{ m/s})^2 \left[\frac{\pi (0.1 \text{ m})^2}{4} \right] \sin 60 + 200 \text{ kg} (9.81 \text{ m/s}^2)$$

$$= 8083.6 \text{ N}$$

$$F_b = \rho V_{\text{disp}} g$$

$$V_{\text{disp}} = \frac{F_b}{\rho g} = \frac{8083.6 \text{ N}}{(1000 \text{ kg/m}^3) (9.81 \text{ m/s}^2)}$$

$$= \boxed{0.824 \text{ m}^3}$$