

ITI1100C
Assignment # 2
SOLUTIONS

2.1

(a)

x y z	x+y+z	(x+y+z)'	x'	y'	z'	x'y'z'
000	0	1	1	1	1	1
001	1	0	1	1	0	0
010	1	0	1	0	1	0
011	1	0	1	0	0	0
100	1	0	0	1	1	0
101	1	0	0	1	0	0
110	1	0	0	0	1	0
111	1	0	0	0	0	0

x y z	(xyz)	(xyz)'	x'	y'	z'	x ² +y ² +z ²
000	0	1	1	1	1	1
001	0	1	1	1	0	1
010	0	1	1	0	1	1
011	0	1	1	0	0	1
100	0	1	0	1	1	1
101	0	1	0	1	0	1
110	0	1	0	0	1	1
111	1	0	0	0	0	0

(b)

x y z	x+y+z	x+y	x+z	(x+y)(x+z)
000	0	0	0	0
001	0	0	1	0
010	0	1	0	0
011	1	1	1	1
100	1	1	1	1
101	1	1	1	1
110	1	1	1	1
111	1	1	1	1

(c)

x y z	x(y+z)	xy	xz	xy+xz
000	0	0	0	0
001	0	0	0	0
010	0	0	0	0
011	0	0	0	0
100	0	0	0	0
101	1	0	1	1
110	1	1	0	1
111	1	1	1	1

(d)

x y z	x	y+z	x+(y+z)	(x+y)	(x+y)+z
000	0	0	0	0	0
001	0	1	1	0	1
010	0	1	1	1	1
011	0	1	1	1	1
100	1	0	1	1	1
101	1	1	1	1	1
110	1	1	1	1	1
111	1	1	1	1	1

(e)

x y z	yz	x(yz)	xy	(xy)z
000	0	0	0	0
001	0	0	0	0
010	0	0	0	0
011	1	0	0	0
100	0	0	0	0
101	0	0	0	0
110	0	0	1	0
111	1	1	1	1

2.4

(a) $xz' + xyz + xz' = z' + xyz = (z + z')(z' + xy) = xy + z'$

(b) $(x'y' + z)' + z + xy + wz = (x'y')'z' + z + xy + wz = [(x + y)z' + z] + xy + wz$

$= (z + z')(z + x + y) + xy + wz = z + wz + x + xy + y = z(1 + w) + x(1 + y) + y = x + y + z$

- (c) $w'x(z' + y'z) + x(w + w'yz) = x(w'z' + w'y'z + w + w'yz)$
 $= x(w'z' + w + w'z(y + y')) = x(w + w'(z' + z)) = x(w + w') = x$
- (d) $(w' + y)(w' + y')(w + x + y'z) = (w' + yy')(w + x + y'z) = w'(w + x + y'z)$
 $= ww' + w'x + w'y'z = w'(x + y'z)$
- (e) $wxy'z + w'xz + wxyz = wx(y + y')z + w'xz = wxz + w'xz = xz$

2.7

(c)

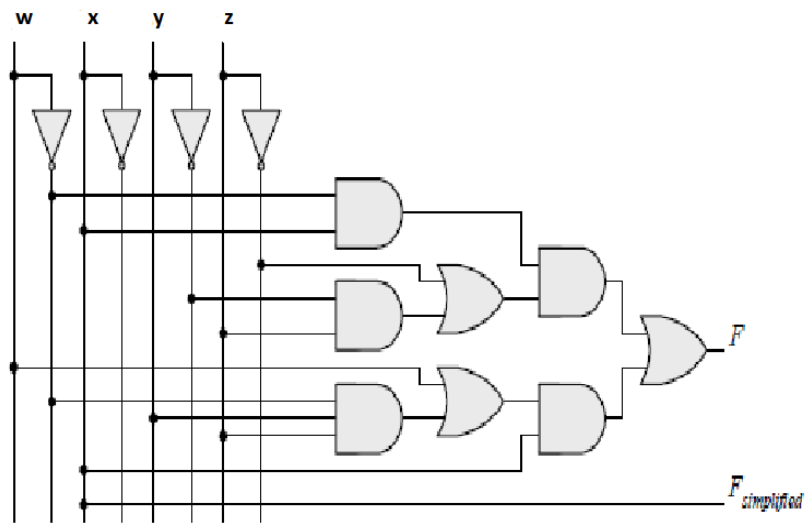

(d)

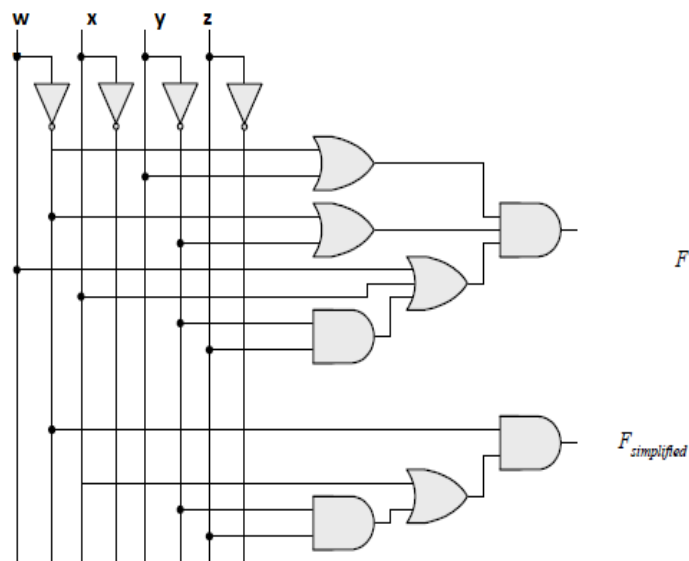

(e)

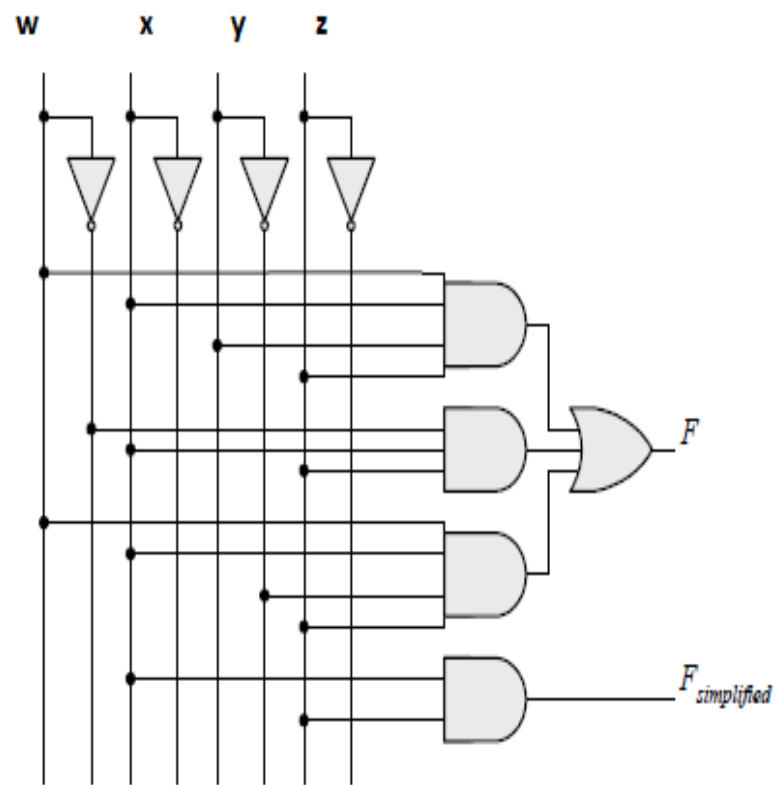

2.9

(a) $F' = (xy' + x'y)' = (xy')'(x'y)' = (x' + y)(x + y') = xy + x'y'$

(b) $F' = [(a + c)(a + b')(a' + b + c)]' = (a + c)' + (a + b')' + (a' + b + c)'$
 $= a'c' + a'b + ab'c$

(c) $F' = [z + z'(v'w + xy)]' = z'[z'(v'w + xy)]' = z'[z'v'w + xyz]'$
 $= z'[(z'v'w)'(xyz)'] = z'[(z + v + w')(x' + y' + z)]$
 $= z'(v + w')(x' + y')$

2.11

(a) $F(x, y, z) = \odot(1, 4, 5, 6, 7)$

(b) $F(a, b, c) = \odot(0, 4, 5, 7)$

$F = xy + xy' + y'z$

x y z	F
0 0 0	0
0 0 1	1
0 1 0	0
0 1 1	0
1 0 0	1
1 0 1	1
1 1 0	1
1 1 1	1

$F = ac + b'c'$

a b c	F
0 0 0	1
0 0 1	0
0 1 0	0
0 1 1	0
1 0 0	1
1 0 1	1
1 1 0	0
1 1 1	1

2.13 (a)

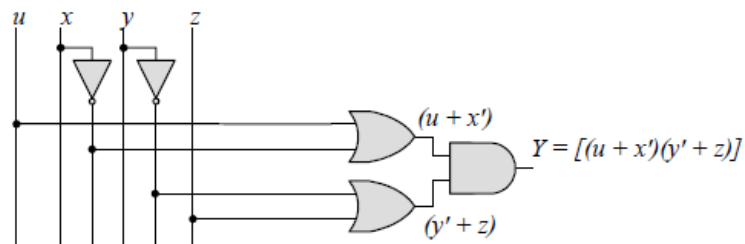

(b)

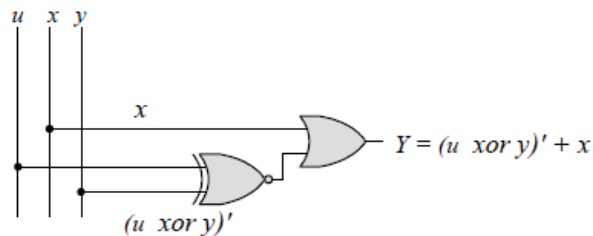

(c)

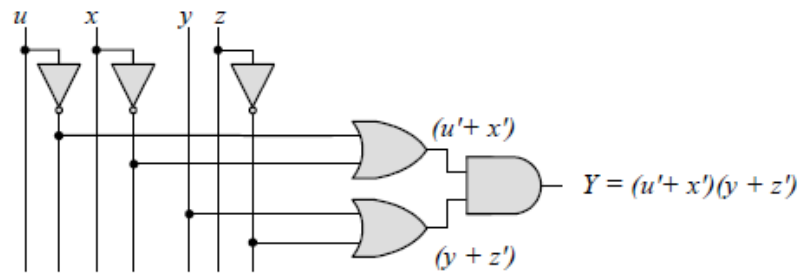

(d)

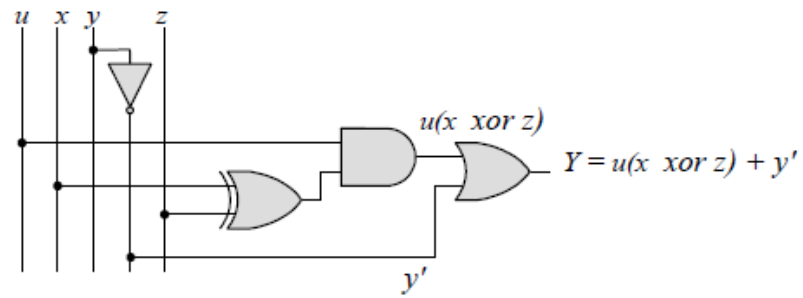

(e)

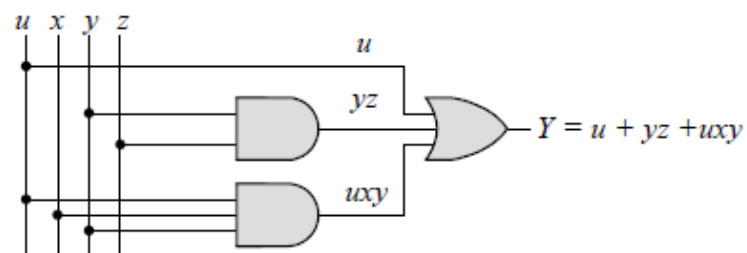

(f)

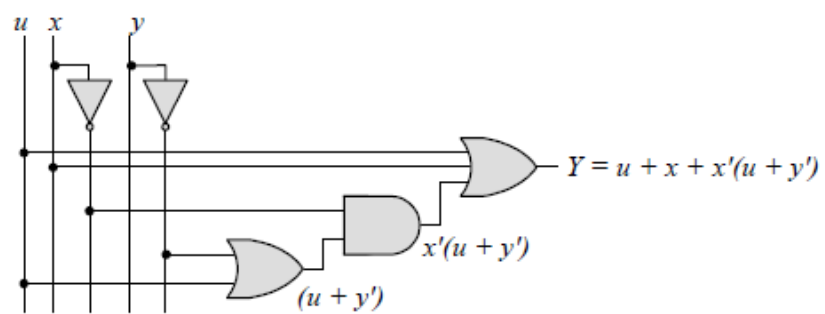

2.14 (a)

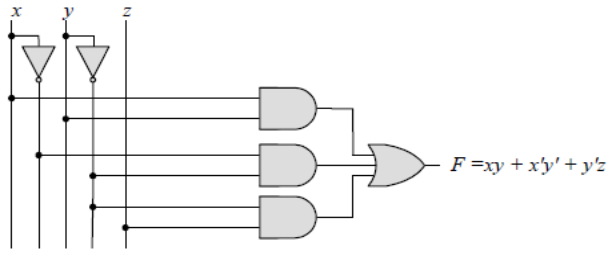

(b)

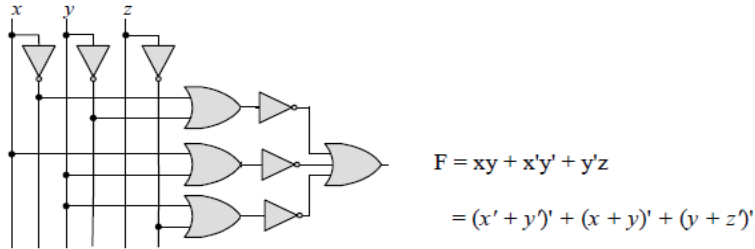

(c)

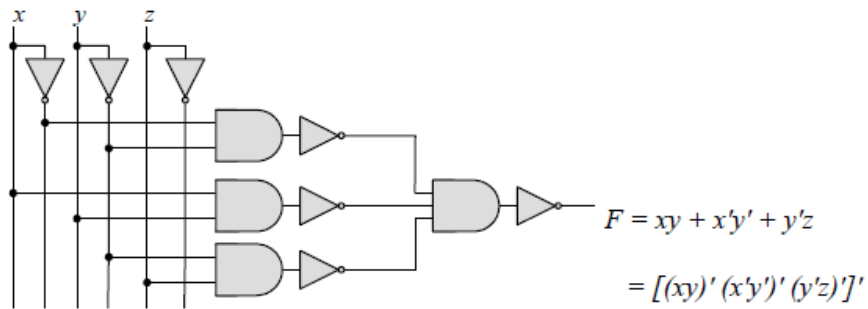

(d)

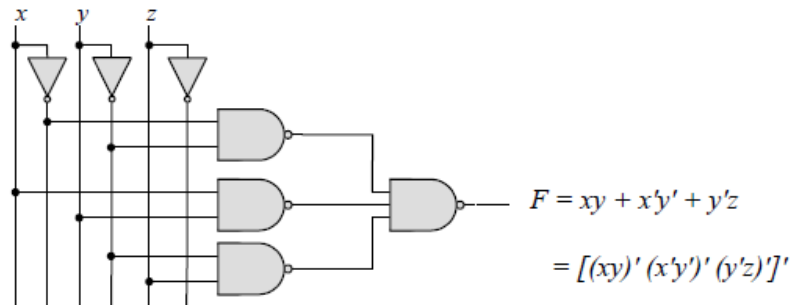

(e)

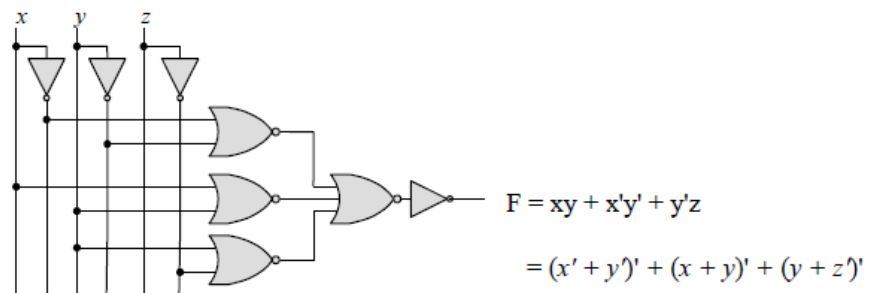

2.18

(a)

wx y z	F
00 0 0	0
00 0 1	1
00 1 0	0
00 1 1	0
01 0 0	0
01 0 1	1
01 1 0	1
01 1 1	1
10 0 0	0
10 0 1	1
10 1 0	1
10 1 1	1
11 0 0	0
11 0 1	1
11 1 0	1
11 1 1	1

$F = xy'z + x'y'z + w'xy + wx'y + wxy$
 $F = \Sigma(1, 5, 6, 7, 9, 10, 11, 13, 14, 15)$

(b)

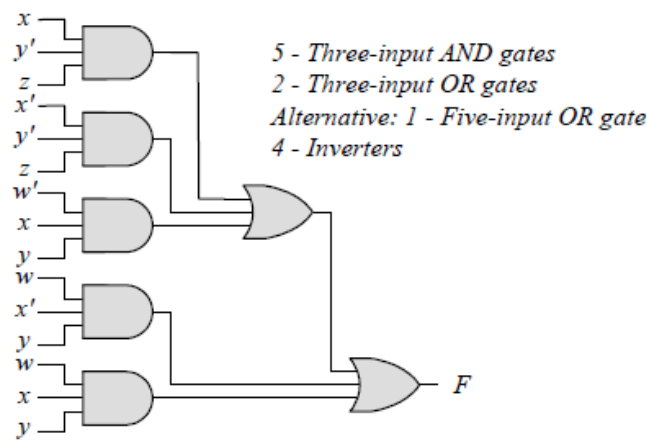

(c) $F = xy'z + x'y'z + w'xy + wx'y + wxy = y'z + xy + wy = y'z + y(w + x)$

(d) $F = y'z + yw + yx = \Sigma(1, 5, 9, 13, 10, 11, 13, 15, 6, 7, 14, 15)$
 $= \Sigma(1, 5, 6, 7, 9, 10, 11, 13, 14, 15)$

(e)

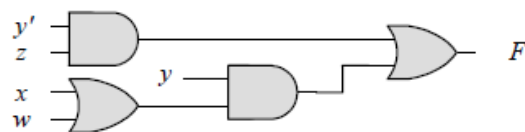

1 - Inverter, 2 - Two-input AND gates, 2 - Two-input OR gates