Chapter 2

Boolean Algebra and Logic Gates

Binary Logic

- Binary logic deals with

- 1 - **Variables** that can take on **two** discrete **values**

→ *Values can be called **True, False, yes, no**, etc.*

- 2 - **Operations** that assume **LOGICAL** Meaning

→ *Binary logic is equivalent to **Boolean algebra***

Boolean Algebra

- **Basic** mathematics required for the description of digital circuits
 - used to describe the different interconnections of digital circuits
 - the variable used in the Boolean algebra are **called Boolean variables**
- We will study **two-valued** Boolean algebra and functions with simplifications using basic Boolean Identities

Two-valued Boolean Algebra

- It consists of

1- Boolean Variables

- Designated by letters of the alphabet such as A, B, C, x, y, z etc.
- Each variable **can have two and only two distinct values: 1 and 0 (True, False)**
- Can be a Function of some other Boolean variables
($F=ABC$)

2- Boolean Operations

- There are three Basic logical operations:
AND, OR, and NOT

Basic Boolean Operations- AND operation

- Represented by a dot or by the absence of an operator

Example: $x.y = or \quad xy=z$

read: $x \text{ AND } y \text{ is equal to } z$

Interpretation: $Z = 1 \text{ if and only if } x = 1 \text{ AND } y = 1$

Otherwise $z = 0$

Truth table:

x	y	xy
0	0	0
0	1	0
1	0	0
1	1	1

Truth table gives the value of z for all possible values of x and y

Don't confuse this with binary multiplication operation

Basic Boolean Operations- *OR* operation

- *Represented by a plus sign (+)*

Example: $x + y = z$

read: x *OR* y *is equal to* z

Interpretation: $z = 1$ *if* $x = 1$ *or if* $y = 1$ *or if both* $x = 1$ *and* $y = 1$. $z = 0$ *if* $x = 0$ *and* $y = 0$

Truth table:

x	y	$x+y$
0	0	0
0	1	1
1	0	1
1	1	1

Truth table gives the value of z for all possible values for x and y

Don't confuse this with binary addition operation

Basic Boolean Operations- *NOT* operation

- *Represented by a prime or an overbar (also called complement)*

Example: $x' = z$ (or $\bar{x} = z$)

read: **Not x is equal to z**

Interpretation: $z =$ “what x is not”

$x = 1$ then $z = 0$; $x = 0$ then $z = 1$

Truth table:

x	x'
0	1
1	0

Truth table gives the value of z for all possible values for x

Binary Logic and Binary Signals

- For simplicity, we often still write digits instead:
 - 1 is true
 - 0 is false
- We will use this interpretation along with special operations to *design functions* and *logic circuits* for doing arbitrary computations.

Logic Gates

- **Logic gates are electronic circuits that operate on one or more input signal to produce an output signal**
- Basic operations can be implemented in hardware using a Basic logic gate.
 - Symbols for each of the logic gates are shown below.
 - These gates output the **product**, **sum** or **complement** of their inputs

Logic Operation: **AND (product)**
of two inputs

OR (sum) of
two inputs

NOT
(complement)
With one input

Representation: $x \cdot y$, or xy

$x + y$

x'

Logic gate:

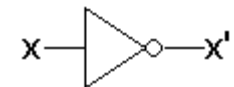

Gates with Multiple Inputs

- AND and OR Gates may have more than 2 input signals

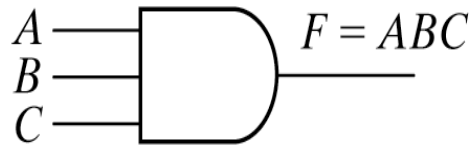

(a) Three-input AND gate

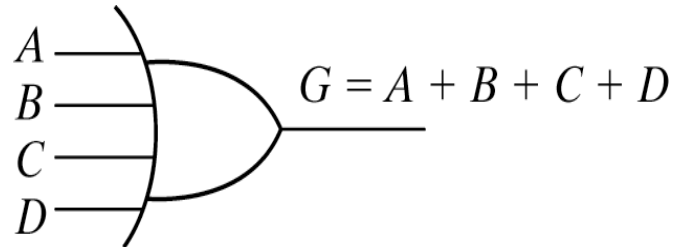

(b) Four-input OR gate

Binary Signals

- Computers use voltages to represent information.
- Two voltage levels are used to represent a binary value
“1” and “0”
- Some digital systems for example may define that:
 - Binary “0” is equal to 0 Volt
 - Binary “1” is equal to 4 Volt

→ *It's convenient for us to translate these voltages into values 1 and 0.*

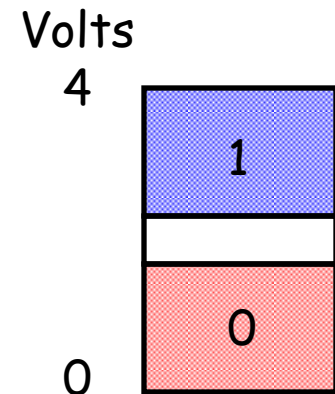

Binary Logic and Binary Signals

- It's also possible to think of voltages as representing two *logical* values, *true* and *false*.
 - These logical values are called Boolean values

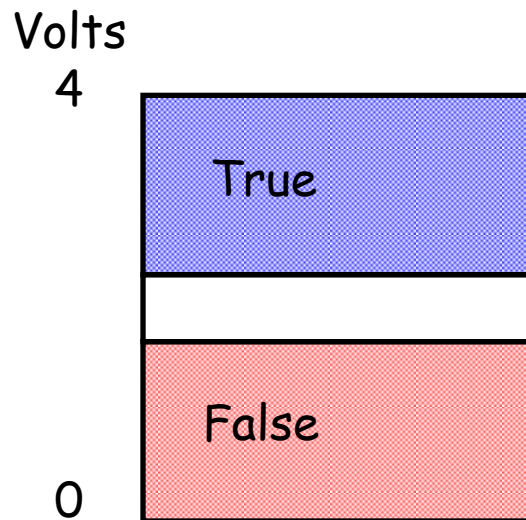

Logic Gates - Signals

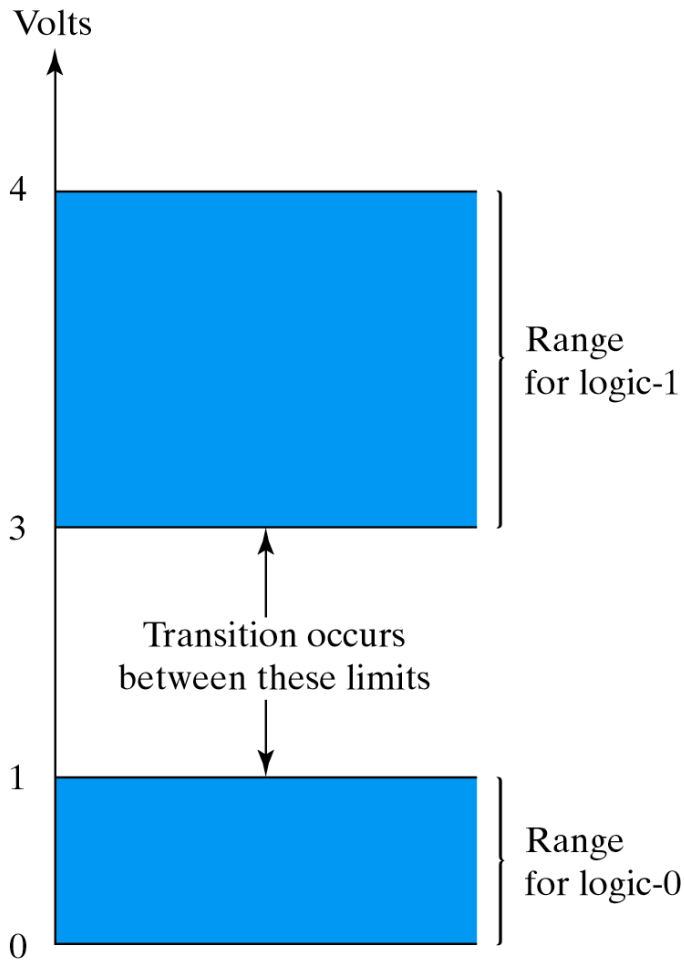

Example

two input signals

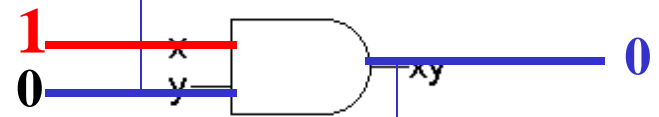

one output signal

Fig. 1-3 Example of binary signals

Logic Gates - Signals

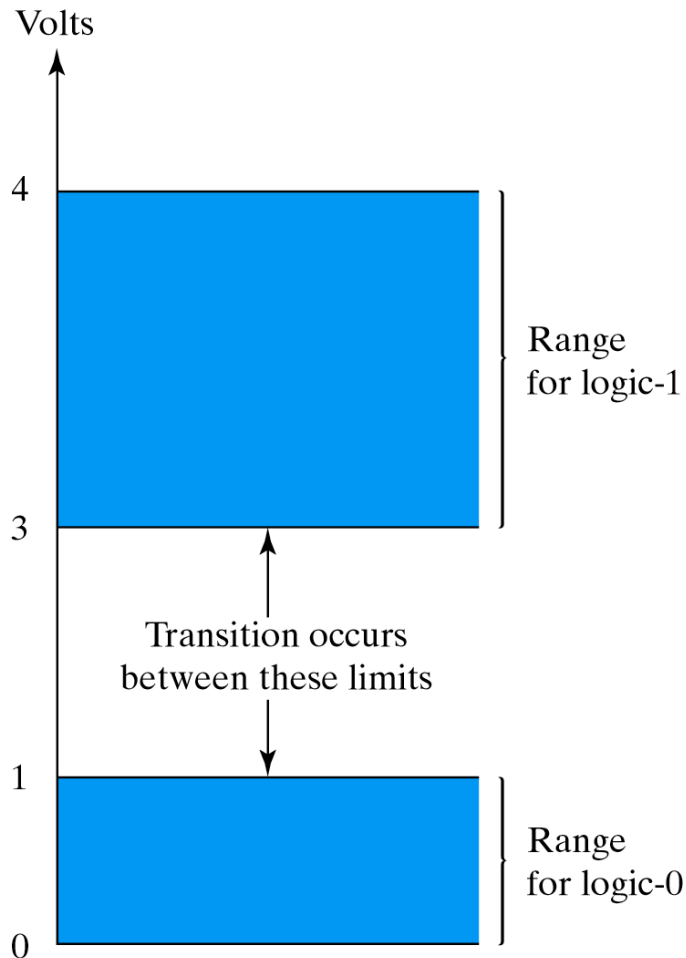

Example

2 input signals

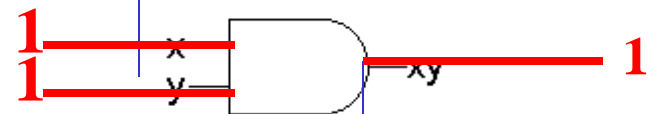

1 output signal

Fig. 1-3 Example of binary signals

Timing Diagram –Input and output signals

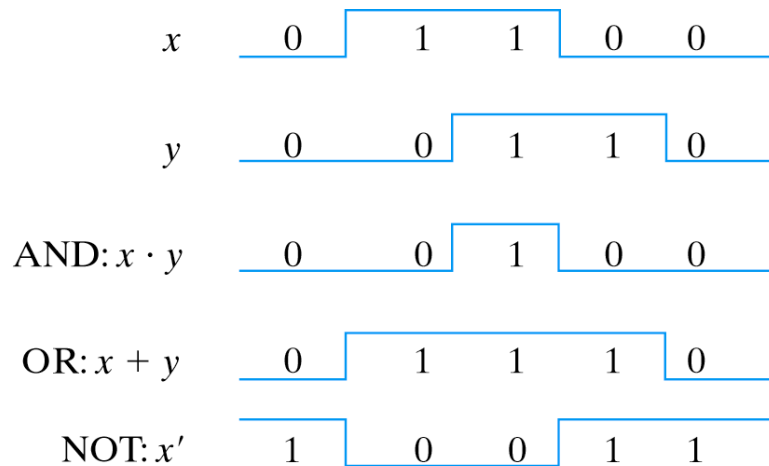
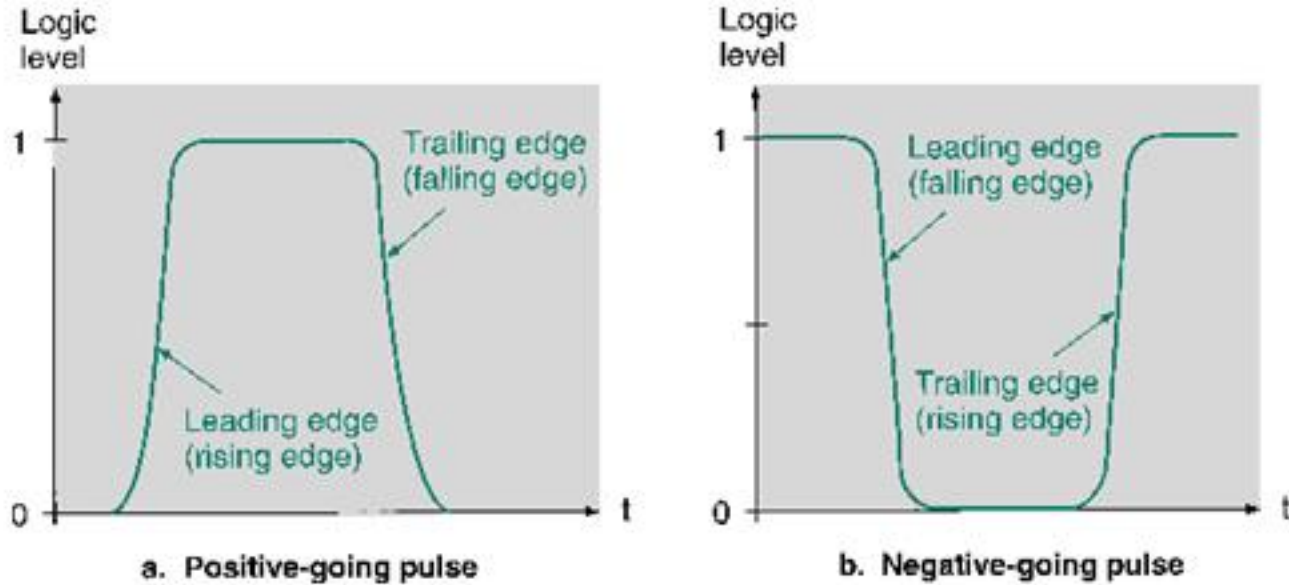

Fig. 1-5 Input-output signals for gates

Basic and Other Logic gates

• Basic Logic gate

- AND
- OR
- NOT



These are called “fundamental logic gates” as all other gates and digital Circuits can be created from these gates.

• Other Logic gates

- NAND
- NOR



These are called “Universal logic gates” as any digital circuit can be designed by just using these gates

- XOR
- XNOR

The NAND & NOR Gates

- We can use a NAND and NOR gates to implement all three of the *basic operations* (AND,OR,NOT).

→ They are said to be **functionally complete**

→ Both NAND and NOR gates are very valuable as any design can be realized using either one.

- It is easier to build digital circuits using all NAND or NOR gates than to combine AND,OR, and NOT gates.

- NAND/NOR gates are typically faster and cheaper to produce.

The NAND Gate

- The NAND gate is a combination of an AND gate followed by an inverter (NOT gate).
- We can use a NAND gate to implement all three of the *basic operations* (AND,OR,NOT).
- Such a gate is said to be **functionally complete**.

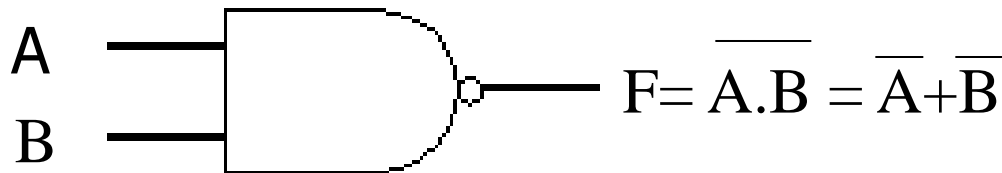

A	B	F
0	0	1
0	1	1
1	0	1
1	1	0

The NOR Gate

- This is a NOR gate. It is a combination of an OR gate followed by an inverter.
- like the NAND gate, the NOR gate is **functionally complete** → any logic function can be implemented using just NOR gates.

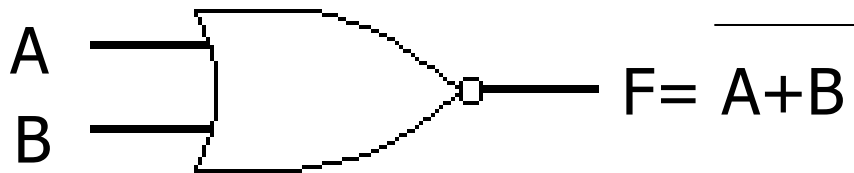

A	B	F
0	0	1
0	1	0
1	0	0
1	1	0

The XOR Gate (Exclusive-OR)

- This is a XOR gate.
- XOR gates assert their output when exactly one of the inputs is asserted, hence the name.
- The operator symbol for this operation is \oplus
 $1 \oplus 1 = 0$ and $1 \oplus 0 = 1$.

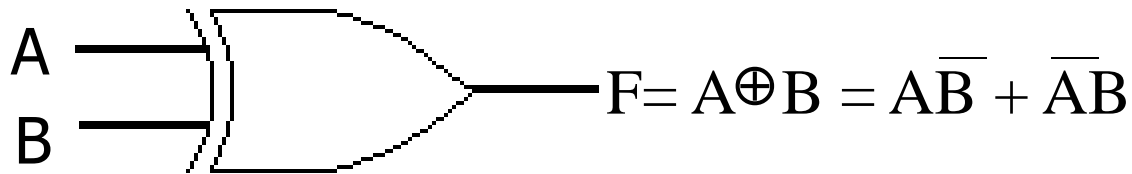

A	B	F
0	0	0
0	1	1
1	0	1
1	1	0

The XNOR Gate

- This functions as an exclusive-NOR gate, or simply the complement of the XOR gate.
- The symbol for this operation is \odot
 $1 \odot 1 = 1$ and $1 \odot 0 = 0$.

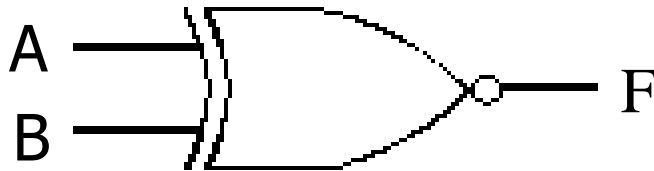

$$F = \overline{A \oplus B} = (AB) + (\overline{A} \cdot \overline{B}) = AB + A'B'$$

A	B	F
0	0	1
0	1	0
1	0	0
1	1	1

Boolean expressions (functions)

- **We can use the basic operations to form more complex expressions:**

$$f(x,y,z) = x y' + z x'$$

- **Some terminology and notation:**
 - **f** is the name of the function.
 - **Term** is an implementation with a gate: in this example f has two terms $x y'$ and $z x$
 - (x,y,z) are the **input variables**, each representing 1 or 0.
 - A **literal** is any occurrence of an input variable or its complement. The function above has four literals: x , y' , z , and x' .

Precedence for Evaluation of Boolean Expression

- Precedence are important.

– **Parentheses first (if any)** then

NOT has the highest precedence, followed by **AND**, and then **OR**.

$$\rightarrow f(x,y,z) = (x + y')z + x'$$

– Fully parenthesized, the function above would be kind of messy:

$$f(x,y,z) = (((x + (y'))z) + x')$$

Truth Table

- A truth table shows all possible inputs and outputs of a function. Each input variable represents either 1 or 0.
 - A function with n variables has 2 power n possible combinations of inputs.
- Inputs are listed in binary order-example, from 000 to 111.

$$f(x,y,z) = (x + y')z + x'$$



$$\begin{aligned}f(0,0,0) &= (0 + 1)0 + 1 = 1 \\f(0,0,1) &= (0 + 1)1 + 1 = 1 \\f(0,1,0) &= (0 + 0)0 + 1 = 1 \\f(0,1,1) &= (0 + 0)1 + 1 = 1 \\f(1,0,0) &= (1 + 1)0 + 0 = 0 \\f(1,0,1) &= (1 + 1)1 + 0 = 1 \\f(1,1,0) &= (1 + 0)0 + 0 = 0 \\f(1,1,1) &= (1 + 0)1 + 0 = 1\end{aligned}$$

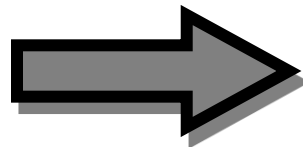

x	y	z	f(x,y,z)
0	0	0	1
0	0	1	1
0	1	0	1
0	1	1	1
1	0	0	0
1	0	1	1
1	1	0	0
1	1	1	1

Boolean Expression and Logic Circuits

- A Boolean expression (function) can be converted into a circuit by *combining* basic gates.
- Example:
 - The diagram below shows the inputs and outputs of each gate.
 - The precedences are explicit in a circuit.

$$f(x,y,z) = (x + y')z + x'$$

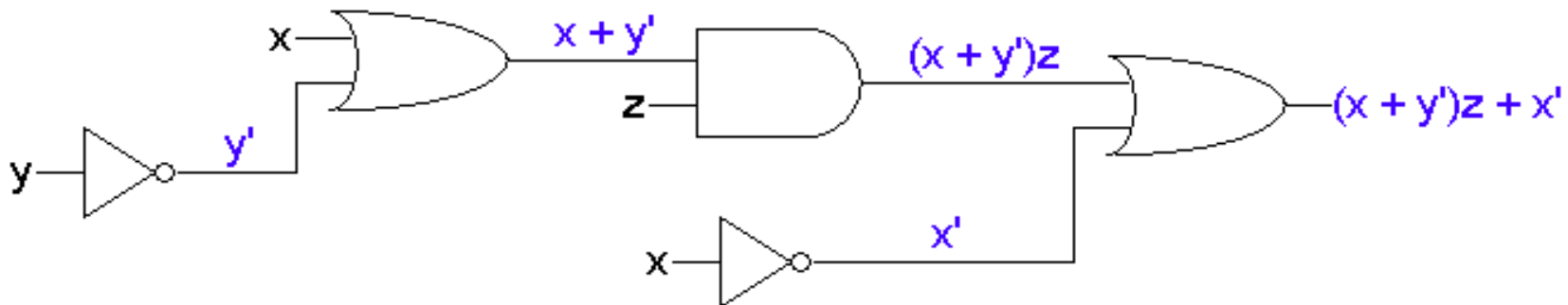

Obtaining Boolean Expressions

- **Expressions may be obtained from:**
 - English language description
 - Truth table;
 - Logic circuit.

Obtaining Boolean Expressions

- The Boolean expression (un-simplified) can be obtained from the truth table: Consider the following arbitrary Truth Table

A	B	C	F ₁	
0	0	0	0	
0	0	1	0	
0	1	0	1	$A'BC'$
0	1	1	1	$A'BC$
1	0	0	1	$AB'C'$
1	0	1	1	$AB'C$
1	1	0	1	ABC'
1	1	1	1	ABC

We can also write the function as:

$$F_1(A,B,C) = A'BC' + A'BC + AB'C' + AB'C + ABC' + ABC$$

Obtaining Boolean Expressions

Using the false terms in the truth table

- Sometimes it is easier to work with the terms that describe when the function is false.
- For example, if a function has four variables then there are sixteen possible states.
 - If for instance thirteen out of sixteen were true, then only three out of sixteen are false. **Fewer terms makes it easier**
- In our example, two out of eight are false.

Obtaining Boolean Expressions

- The Boolean expression (un-simplified) can be obtained from the truth table using **false terms**

So we can also write the function **NOT** F_1 as:

$$\overline{F_1}(A,B,C) = A'B'C' + A'B'C$$

A	B	C	F_1	
0	0	0	0	$A'B'C'$
0	0	1	0	$A'B'C$
0	1	0	1	
0	1	1	1	
1	0	0	1	
1	0	1	1	
1	1	0	1	
1	1	1	1	

Obtaining The Truth Table - Example

Design a digital circuit that will be used to control an Alarm bell. This Alarm bell is to be installed in a room to protect it from unauthorized entry.

Sensor devices provide the following logic signals

C = 1 The control system is active

D = 1 The room door is closed

M = 1 There is a motion in the room

Q = 1 The room is open to the public

i) Obtain the truth table

ii) derive the Boolean expression using **true** terms

Truth table

C	D	M	Q	Alarm
0	0	0	0	0
0	0	0	1	0
0	0	1	0	0
0	0	1	1	0
0	1	0	0	0
0	1	0	1	0
0	1	1	0	0
0	1	1	1	0
1	0	0	0	1
1	0	0	1	0
1	0	1	0	1
1	0	1	1	0
1	1	0	0	0
1	1	0	1	0
1	1	1	0	1
1	1	1	1	0

$$\text{Alarm} = \text{CD}'\text{M}'\text{Q}' + \text{CD}'\text{M}\text{Q}' + \text{CD}\text{M}\text{Q}'$$

Door should not be open

room is closed to the public → door open + motion

room is closed to the public + door closed → motion

Boolean Identities

- Boolean algebra is used in digital design to **reduce any logical function (expression) to its simplest form**
 - the minimization of the number of literals and the number of terms
 - a circuit with less equipment
- **It is a hard problem (no specific rules to follow)**

Boolean Identities

1. $x + 0 = x$
2. $x \cdot 1 = x$
3. $x + x' = 1$
4. $x \cdot x' = 0$
5. $x + x = x$
6. $x \cdot x = x$
7. $x + 1 = 1$
8. $x \cdot 0 = 0$
9. $(x')' = x$

Basic to Boolean algebra

-
- | | |
|---------------------------------|--------------|
| 10. $x + y = y + x$ | Commutative |
| 11. $xy = yx$ | Commutative |
| 12. $x + (y + z) = (x + y) + z$ | Associative |
| 13. $x(yz) = (xy)z$ | Associative |
| 14. $x(y + z) = xy + xz$ | Distributive |
| 15. $x + yz = (x+y)(x+z)$ | Associative |
-
16. $(x + y)' = x'y'$ DeMorgan
 17. $(xy)' = x' + y'$ DeMorgan
 18. $x + xy = x$ Absorption
 19. $x(x + y) = x$ Absorption

Verifying Boolean Identities-Examples

Theorem : $x+x = x$

$$\begin{aligned}x+x &= (x+x) 1 \\ &= (x+x) (x+x') \\ &= x+xx' \\ &= x+0 \\ &= x\end{aligned}$$

$$x.1=x$$

$$x+x'=1$$

$$x+yz = (x+y)(x+z)$$

$$x.x'=0$$

$$x+0=x$$

Theorem : $x x = x$

$$\begin{aligned}xx &= x x + 0 \\ &= xx + xx' \\ &= x (x + x') \\ &= x 1 \\ &= x\end{aligned}$$

Verifying Boolean Identities-Examples

- DeMorgan's Theorems

$$\rightarrow (x+y)' = x' y'$$

$$\rightarrow (x y)' = x' + y'$$

- By means of truth table

x	y	x+y	$(x+y)'$	x'	y'	$x' y'$
0	0	0	1	1	1	1
0	1	1	0	1	0	0
1	0	1	0	0	1	0
1	1	1	0	0	0	0

Verifying Boolean Identities-Examples

- **Theorem** $x + xy = x$

By means of truth table

x	y	xy	x + xy
0	0	0	0
0	1	0	0
1	0	0	1
1	1	1	1

Simplifying Boolean Expressions

→ Use the Rules of Boolean Algebra

We can simplify the function as:

$$\begin{aligned}F_1(A,B,C) &= A'BC' + A'BC + AB'C' + AB'C + ABC' + ABC \\&= A'B(C'+C) + AB'(C+C') + AB(C'+C) \\&= A'B + AB' + AB \\&= A'B + A(B'+B) \\&= A + A'B\end{aligned}$$

Simplifying Boolean Expressions

Function with four variables

- Giving the following function:

$$\begin{aligned}F_{2a}(A,B,C,D) &= (AB'(C + BD) + A'B')C \\&= (AB'C + \mathbf{AB'BD} + A'B')C \\&= (AB'C + \mathbf{A0D} + A'B')C \\&= (AB'C + \mathbf{0} + A'B')C \\&= (AB'C + A'B')C \\&= AB'CC + A'B'C \\&= AB'C + A'B'C \\&= (\mathbf{A+A'})B'C \\&= B'C\end{aligned}$$

$$F_{2b}(A,B,C,D) = B'C$$

→ the two expressions are equivalent!

→ F_{2a} **requires more logic gates than** F_{2b}

Basic and Other Logic gates

• Basic Logic gate

- AND
- OR
- NOT



These are called “fundamental logic gates” as all other gates and digital Circuits can be created from these gates.

• Other Logic gates

- NAND
- NOR



These are called “Universal logic gates” as any digital circuit can be designed by just using these gates

- XOR
- XNOR

The NAND & NOR Gates

- We can use a NAND and NOR gates to implement all three of the *basic operations* (AND,OR,NOT).

→ They are said to be **functionally complete**

→ Both NAND and NOR gates are very valuable as any design can be realized using either one.

- It is easier to build digital circuits using all NAND or NOR gates than to combine AND,OR, and NOT gates.

- NAND/NOR gates are typically faster and cheaper to produce.

The NAND Gate

- The NAND gate is a combination of an AND gate followed by an inverter (NOT gate).
- We can use a NAND gate to implement all three of the *basic operations* (AND,OR,NOT).
- Such a gate is said to be **functionally complete**.

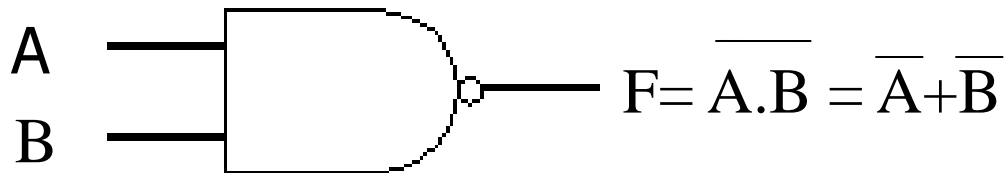

A	B	F
0	0	1
0	1	1
1	0	1
1	1	0

The NAND Gate

→ a NAND gate with both of its inputs driven by the same signal is equivalent to a NOT gate

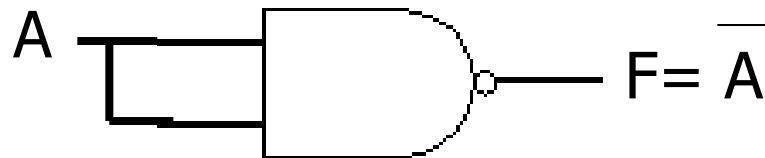

NOT Gate

→ a NAND gate whose output is complemented is equivalent to an AND gate

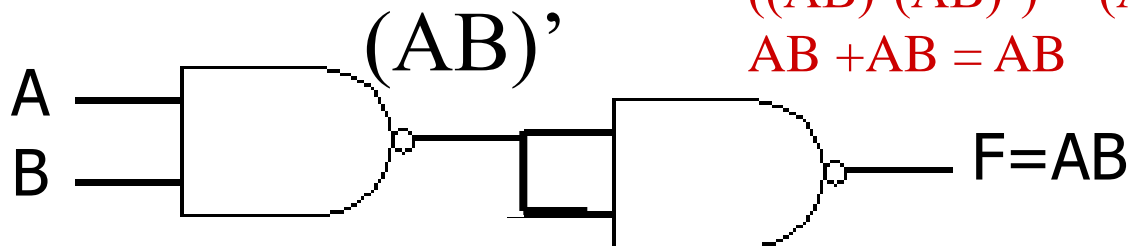

$$\begin{aligned} ((AB)'(AB)')' &= (AB)'' + (AB)'' = \\ &= AB + AB = AB \end{aligned}$$

AND Gate

The NAND Gate

- a NAND gate with complemented inputs acts as an OR gate.

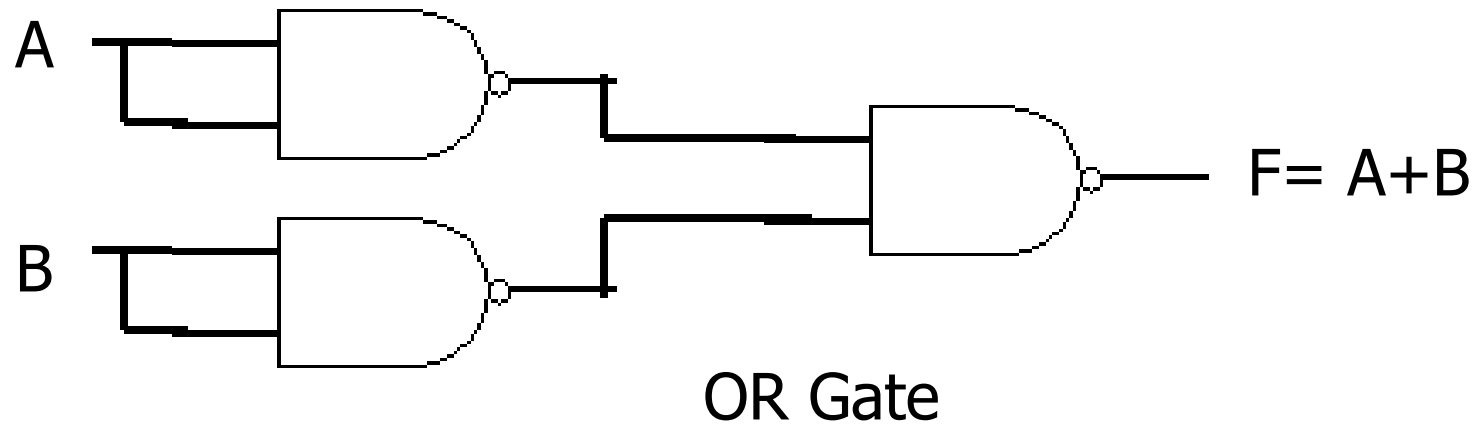

Universality of NAND



(a)

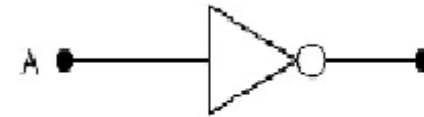

INVERTER

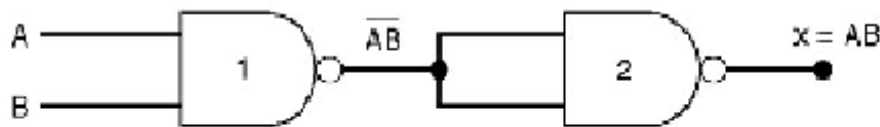

(b)

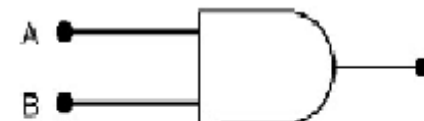

AND

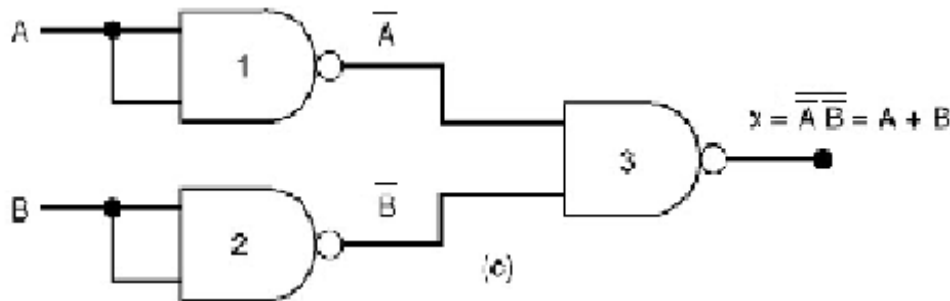

(c)



OR

The NOR Gate

- This is a NOR gate. It is a combination of an OR gate followed by an inverter.
- like the NAND gate, the NOR gate is **functionally complete** → any logic function can be implemented using just NOR gates.

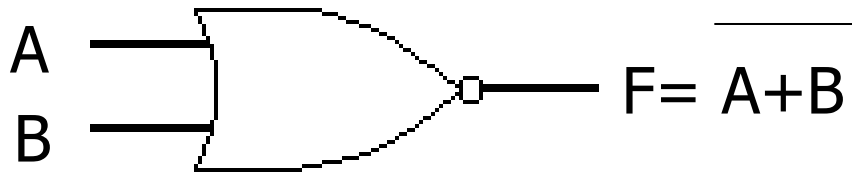

A	B	F
0	0	1
0	1	0
1	0	0
1	1	0

NOR Gate Equivalence

- NOR Symbol, Equivalent Circuit, Truth Table

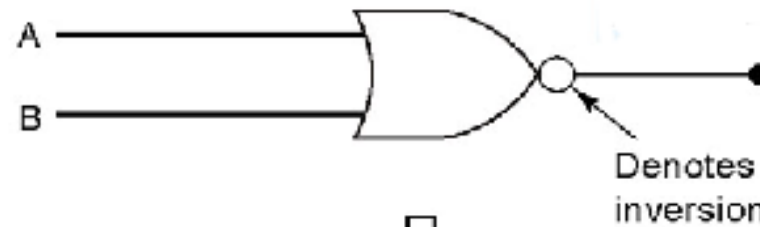

(a) ↓



(b)

A	B	OR		NOR	
		A + B	$\overline{A + B}$		
0	0	0	1		
0	1	1	0		
1	0	1	0		
1	1	1	0		

(c)

NOR Gates-functionally complete

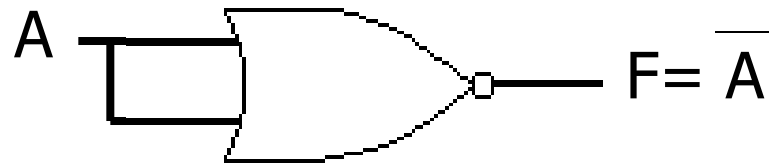

NOT Gate

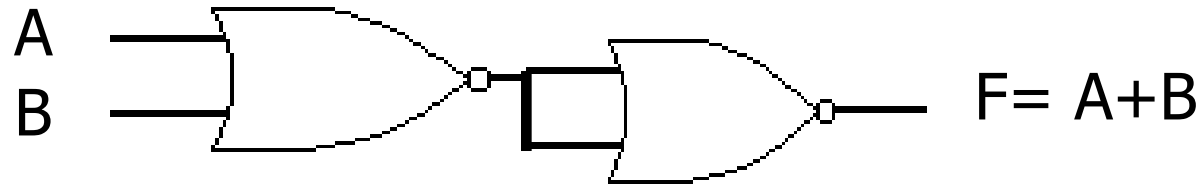

OR Gate

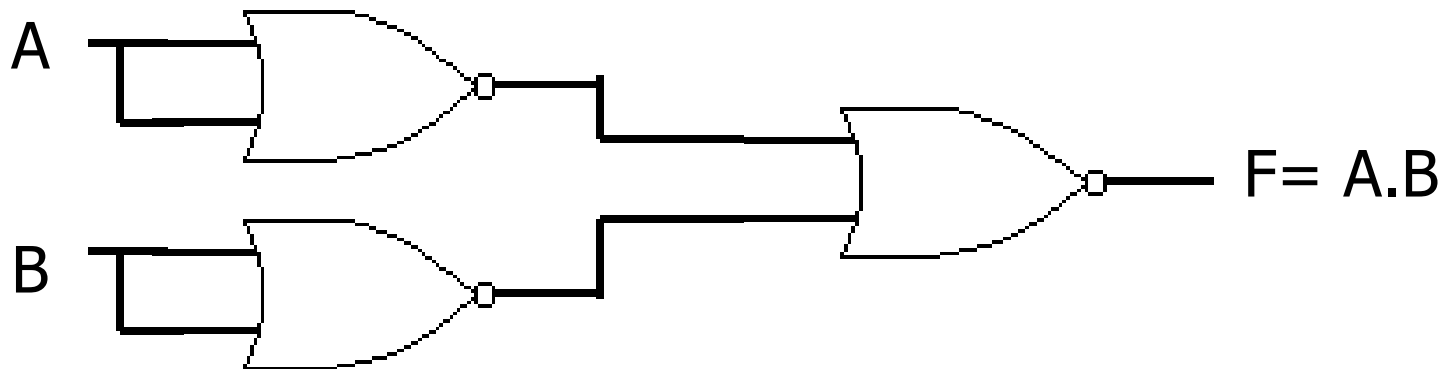

AND Gate

Universality of NOR gate



(a)

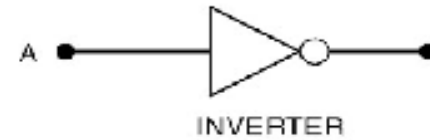

INVERTER

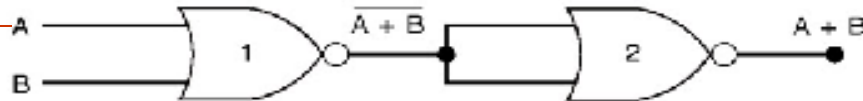

(b)

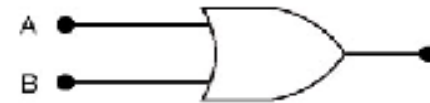

OR

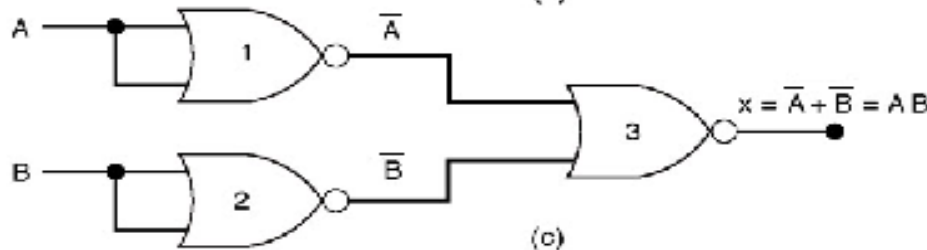

(c)

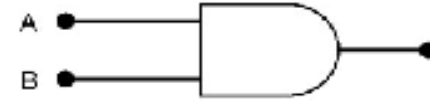

AND

- Equivalent representations of the AND, OR, and NOT gates

$$(A+A)' = A'A' = A'$$

$$((A+B)' + (A+B)')' = (A+B)''(A+B)'' = (A'B')'(A'B')'$$

$$= (A''+B'')(A''+B'') = (A+B)(A+B) = (A+B)$$

The XOR Gate (Exclusive-OR)

- This is a XOR gate.
- XOR gates assert their output when exactly one of the inputs is asserted, hence the name.
- The operator symbol for this operation is \oplus
 $1 \oplus 1 = 0$ and $1 \oplus 0 = 1$.

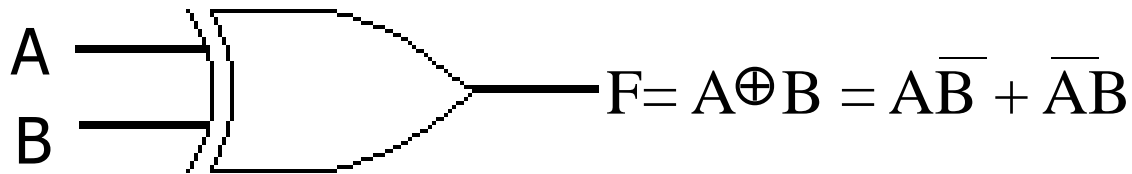

A	B	F
0	0	0
0	1	1
1	0	1
1	1	0

The XNOR Gate

- This functions as an exclusive-NOR gate, or simply the complement of the XOR gate.
- The symbol for this operation is \odot
 $1 \odot 1 = 1$ and $1 \odot 0 = 0$.

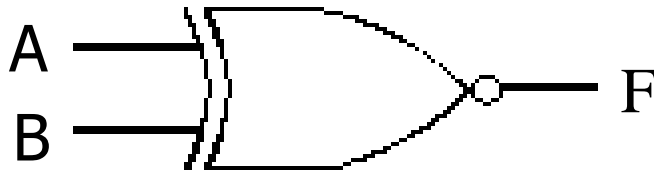

$$F = \overline{A \oplus B} = (AB) + (\overline{A} \cdot \overline{B}) = AB + A'B'$$

A	B	F
0	0	1
0	1	0
1	0	0
1	1	1

Standard Forms

- We have seen how to interpret truth tables, obtain Boolean expressions (functions) then build logic circuits.
 - We have simplified Boolean expressions using Boolean algebra.
- There is a “standard” way of writing Boolean expressions (Functions):**
- **The standard Sum of Products (SOP)**
 - **The standard Product of Sums (POS)**

The standard Sum of Product-Minterms

- A Minterm is one in which all variables appear (only) once.
- Each Minterm represents exactly one combination (row) in truth table.
- n variables give 2^n Minterms.

Truth Table

Decimal value	A	B	C	F	Minterm
0	0	0	0	0	m_0
1	0	0	1	0	m_1
2	0	1	0	1	m_2
3	0	1	1	1	m_3
4	1	0	0	1	m_4
5	1	0	1	1	m_5
6	1	1	0	1	m_6
7	1	1	1	1	m_7

The standard Sum of Products-Function

- SOP are expressions of the form:

$$F(A,B,C, \dots) = (\dots) + (\dots) + (\dots) + \dots$$

- Brackets can contain single or multiple variables
- Such expressions can be implemented using:

$$F(A,B,C, \dots) = (\text{AND's}) \text{ OR } (\text{AND's}) \text{ OR } (\text{AND's}) \text{ OR } \dots$$

The standard Sum of Product-Function

- SOP form not unique, and doesn't necessarily contain all variables, for example:

$$F(A,B,C) = A'B'C' + A'BC + C'A'B + C'AB' + BAC + BAC$$

and $F(A,B,C) = B + B'C'$

are both valid SOP expressions.

The standard Sum of Product-Function

- We Can obtain SOP from truth table (below)

$$F(A,B,C) = A'BC' + A'BC + AB'C' + AB'C + ABC' + ABC$$

A simpler notation is to write as

$$F(A,B,C) = m_2 + m_3 + m_4 + m_5 + m_6 + m_7$$

$$= \sum m_i (2, 3, 4, 5, 6, 7)$$

Decimal value	A	B	C	F	Minterm	
0	0	0	0	0	m_0	$A'B'C'$
1	0	0	1	0	m_1	$A'B'C$
2	0	1	0	1	m_2	$A'BC'$
3	0	1	1	1	m_3	$A'BC$
4	1	0	0	1	m_4	$AB'C'$
5	1	0	1	1	m_5	$AB'C$
6	1	1	0	1	m_6	ABC'
7	1	1	1	1	m_7	ABC

Product of Sums: Function

• From truth table we have

$$F(A,B,C) = (A'B'C' + A'B'C)$$

• Therefore we obtain F from \bar{F} :

$$\begin{aligned} F(A,B,C) &= \overline{\overline{F(A,B,C)}} = \overline{(A'B'C' + A'B'C)} \\ &= (A' + B'' + C'') \cdot (A'' + B'' + C') = (A + B + C) \cdot (A + B + C') \end{aligned}$$

Form Compact $F = M_0 \cdot M_1 = \prod M_i (0, 1)$

Truth Table

Decimal value	A	B	C	F	Minterm	Maxterm	$M_i = \bar{m}_i$
0	0	0	0	0	m_0	M_0	$A+B+C$
1	0	0	1	0	m_1	M_1	$A+B+C'$
2	0	1	0	1	m_2	M_2	$A+B'+C$
3	0	1	1	1	m_3	M_3	$A+B'+C'$
4	1	0	0	1	m_4	M_4	$A'+B+C$
5	1	0	1	1	m_5	M_5	$A'+B+C'$
6	1	1	0	1	m_6	M_6	$A'+B'+C$
7	1	1	1	1	m_7	M_7	$A'+B'+C'$

Obtain SOP and POS from a given expression

- Given an arbitrary Boolean expression
- Work out number of terms (2^n) for n inputs.
- Generate truth table and identify terms for which the function is true - the Minterms.

- Write function as:
$$F = \sum_{i=0}^{n-1} m_i$$

- Alternatively, identify terms for which the function is false and use a Maxterm description.

- Write function :

$$F = \prod_{j=0}^{n-1} M_j \quad j \neq i$$

SOP & POS Implementation using AND and OR

- Two-level implementation

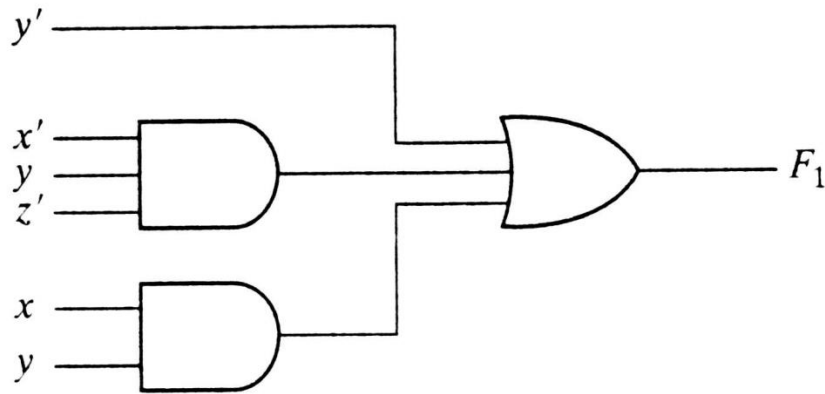

(a) Sum of Products

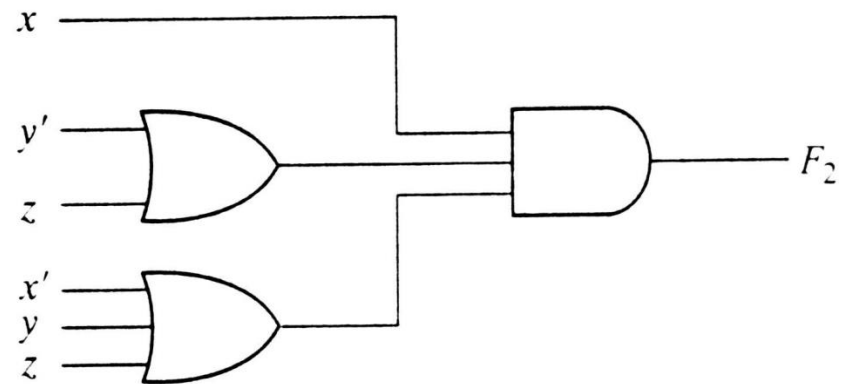

(b) Product of Sums

- Multi-level implementation

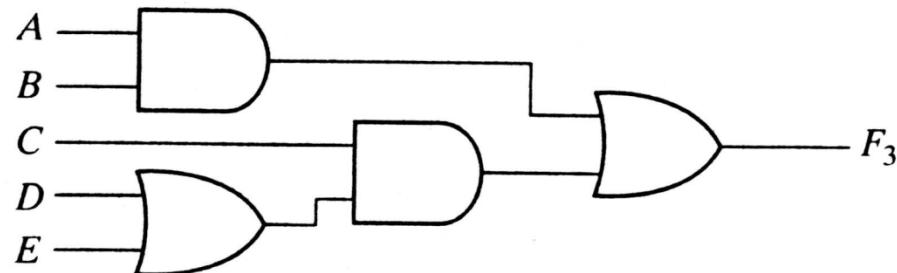

(a) $AB + C(D + E)$

Examples

1- Half Adder

2- Full Adder

3- Deriving SOP and POS from a truth table

4- Simplifying SOP & POS using Boolean identities

Half Adder

→ The half-adder accepts two binary digits on its inputs and produces two binary digits on its outputs: a sum bit and a carry bit.

Truth Table			
A	B	C	S
0	0	0	0
0	1	0	1
1	0	0	1
1	1	1	0

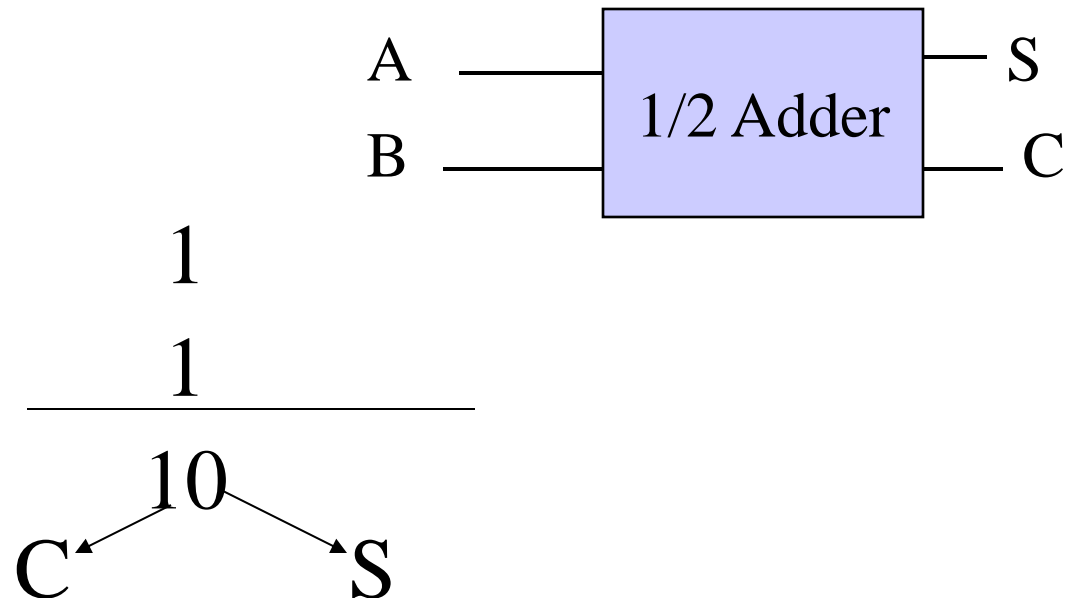

Half-Adder

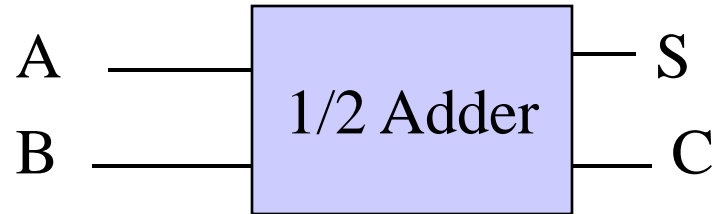

Truth Table

<u>A</u>	<u>B</u>	<u>C</u>	<u>S</u>
0	0	0	0
0	1	0	1
1	0	0	1
1	1	1	0

Logic Function

$$S = A'B + AB'$$

$$S = A \oplus B$$

$$C = A.B$$

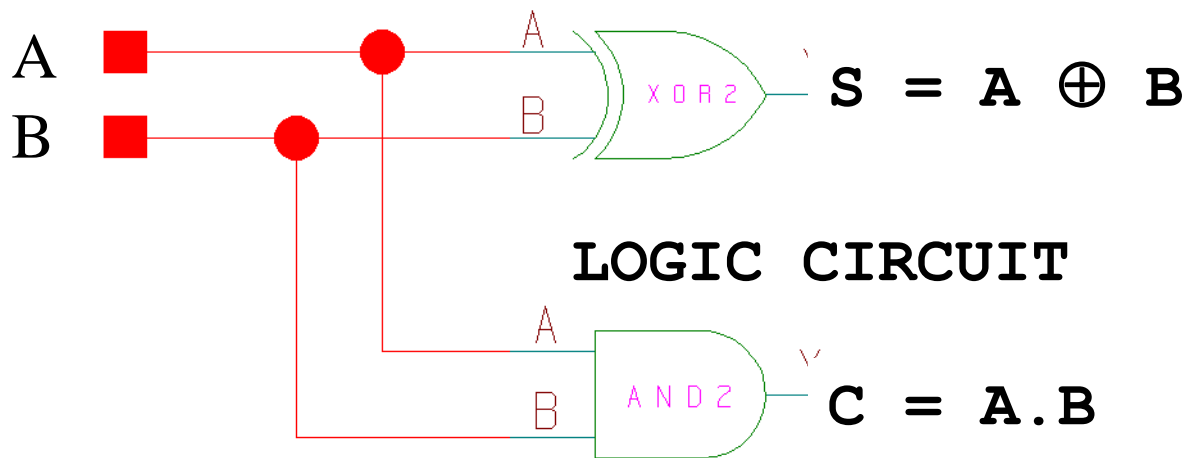

Full Adder

Truth Table

<u>A</u>	<u>B</u>	<u>C</u>	<u>C_o</u>	<u>S</u>
0	0	0	0	0
0	0	1	0	1
0	1	0	0	1
0	1	1	1	0
1	0	0	0	1
1	0	1	1	0
1	1	0	1	0
1	1	1	1	1

→ The Full-adder accepts two input bits and an input carry and generates a sum output and an output carry

→ Basic difference between a full and a half adder is that the full adder **accepts an input carry**



Full-Adder

Logic FUNCTION

Truth Table

A	B	C	C _o	S
0	0	0	0	0
0	0	1	0	1
0	1	0	0	1
0	1	1	1	0
1	0	0	0	1
1	0	1	1	0
1	1	0	1	0
1	1	1	1	1

$$\begin{aligned}
 C_o &= A'BC + AB'C + ABC' + ABC \\
 &= C[A'B + AB'] + AB[C' + C] \\
 &= C[A \oplus B] + AB.1 \\
 &= C(A \oplus B) + AB
 \end{aligned}$$

$$\begin{aligned}
 S &= A'B'C + A'BC' + AB'C' + ABC \\
 &= A'[B'C + BC'] + A[B'C' + BC] \\
 &= A'[B \oplus C] + A[B \oplus C]' \\
 &= A' \overset{[X]}{X} + A \overset{[X]'}{x'} \\
 &= A \oplus X \\
 &= A \oplus B \oplus C
 \end{aligned}$$

Full Adder

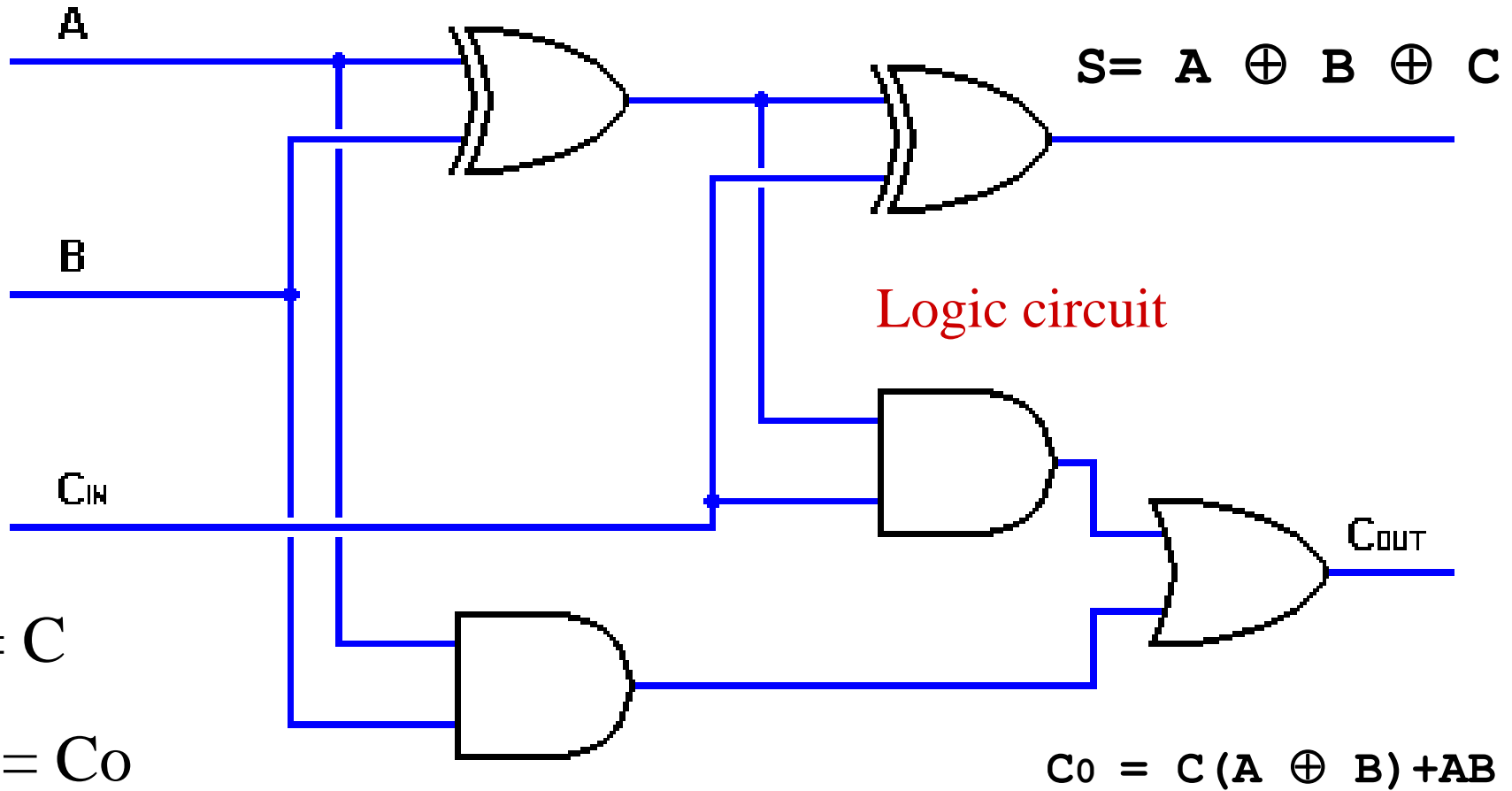

Two bit parallel adder

$$\begin{array}{r} \mathbf{1} \leftarrow \text{Carry bit from right column} \\ 1\ 1 \\ +\ 0\ 1 \\ \hline \end{array}$$

$$\mathbf{1}\ 0\ 0$$

Carry bit from second column
becomes a sum bit

Two bit parallel adder

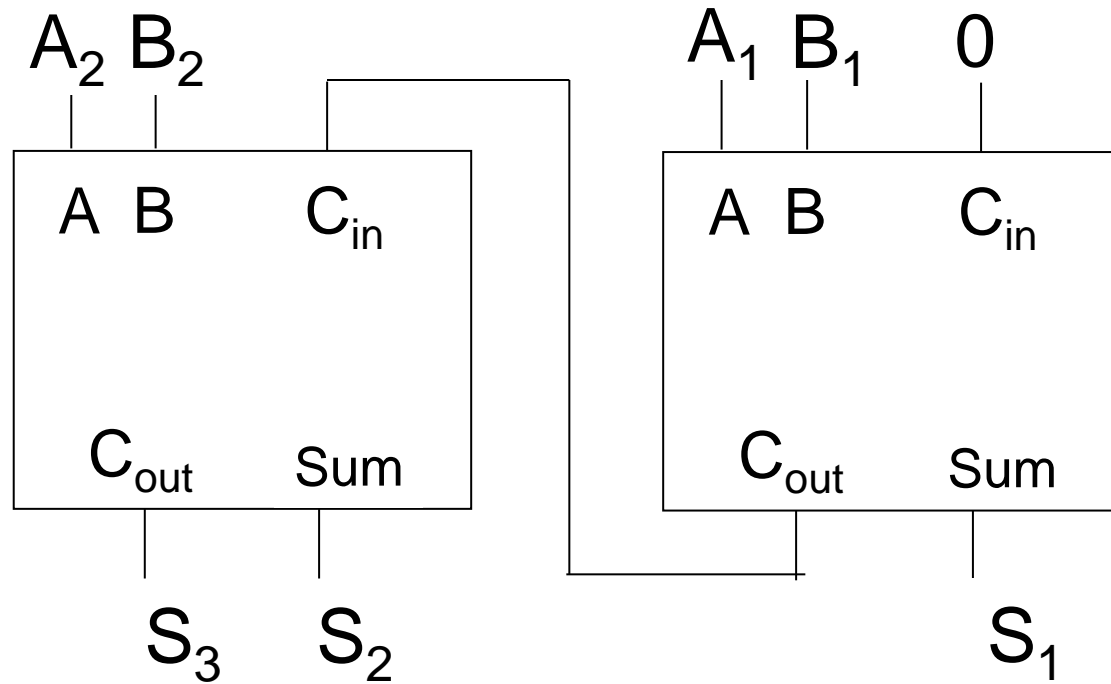

$$\begin{array}{r} A_2 A_1 \\ + B_2 B_1 \\ \hline S_3 S_2 S_1 \end{array}$$

Four bit parallel adder

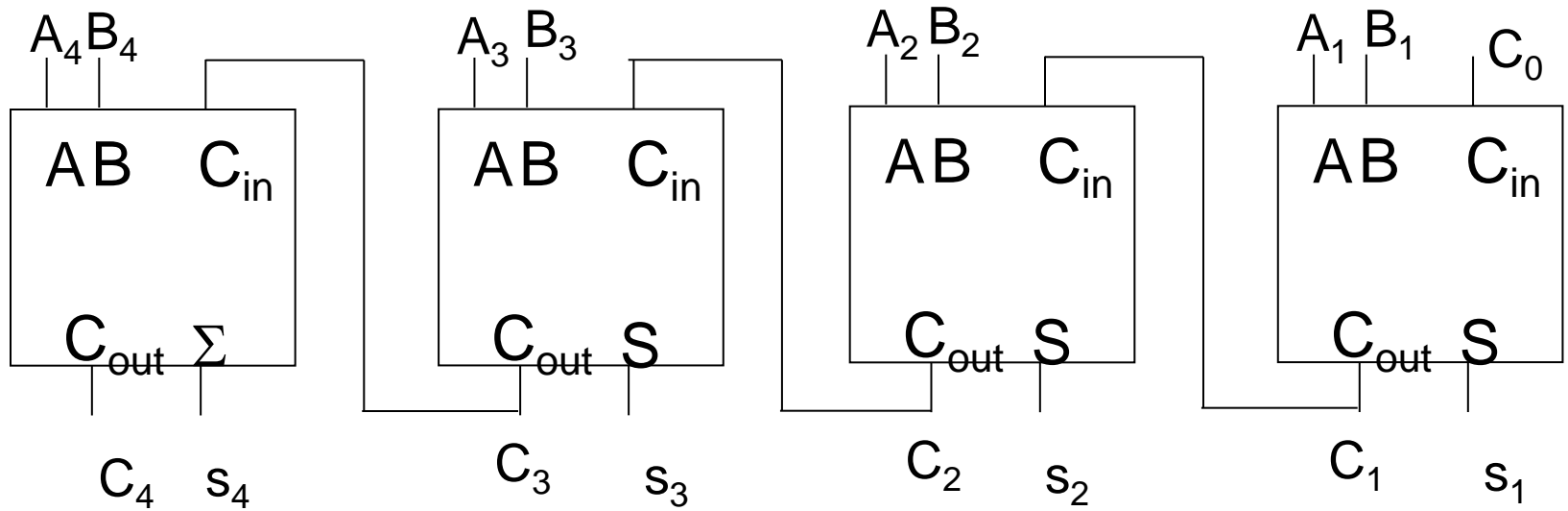

Overflow Examples (review from chapter 1)

- In a 6-bit register

$$+ 17 = \quad 010001$$

$$+ 16 = \quad +\underline{010000}$$

$$= 100001 \quad \rightarrow \text{Overflow}$$

- **100001 = 2's : - (11111) = -(31)₁₀ instead of + (33)₁₀**
- Same with a 7-bit register

$$+ 17 = \quad 0\ 010001$$

$$+ 16 = \quad +\underline{0\ 010000}$$

$$= 0\ 100001$$

$$\mathbf{0100001 = + 33 \text{ No Overflow}}$$

Four bit parallel adder

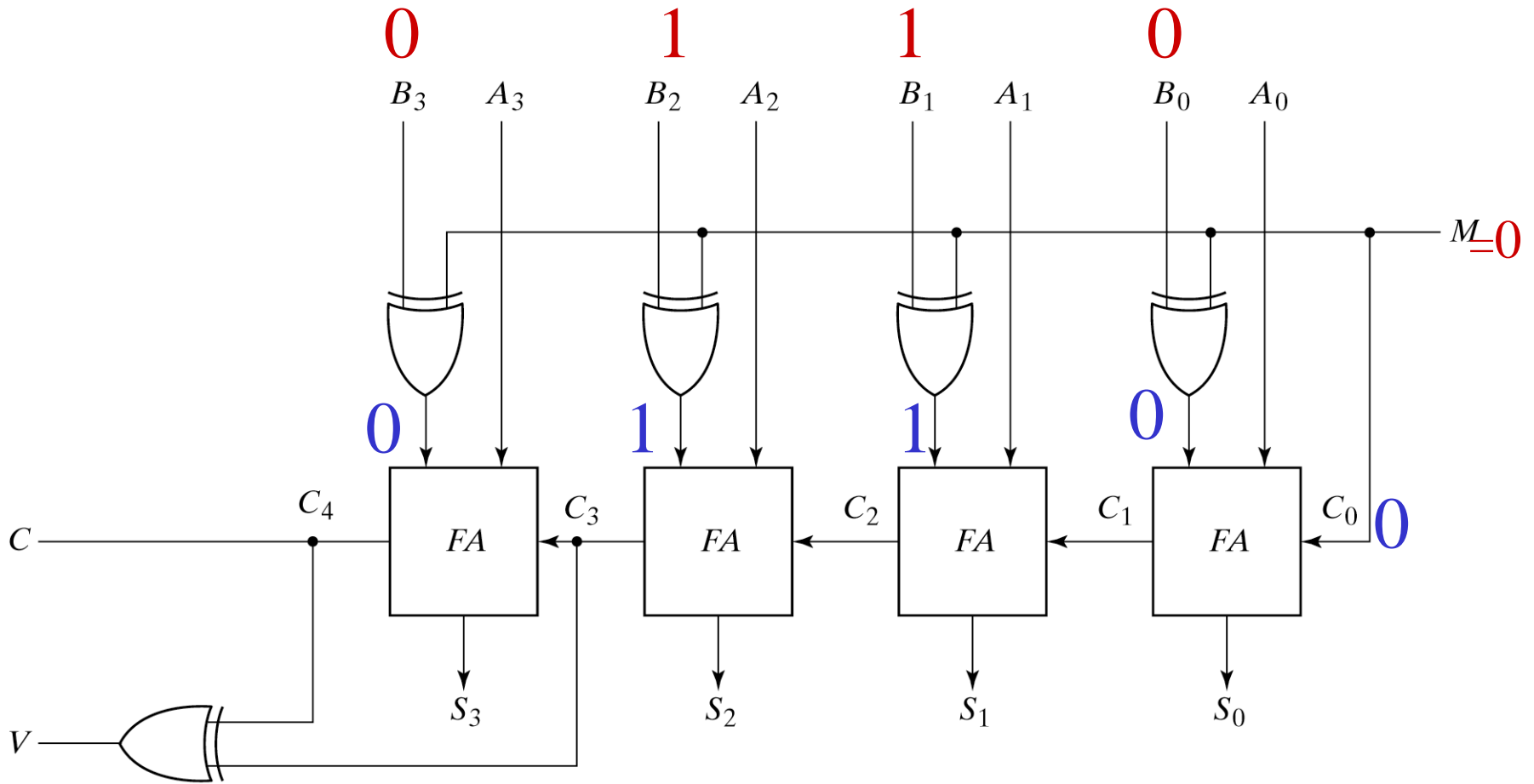

Fig. 4-13 4-Bit Adder Subtractor

Four bit parallel adder

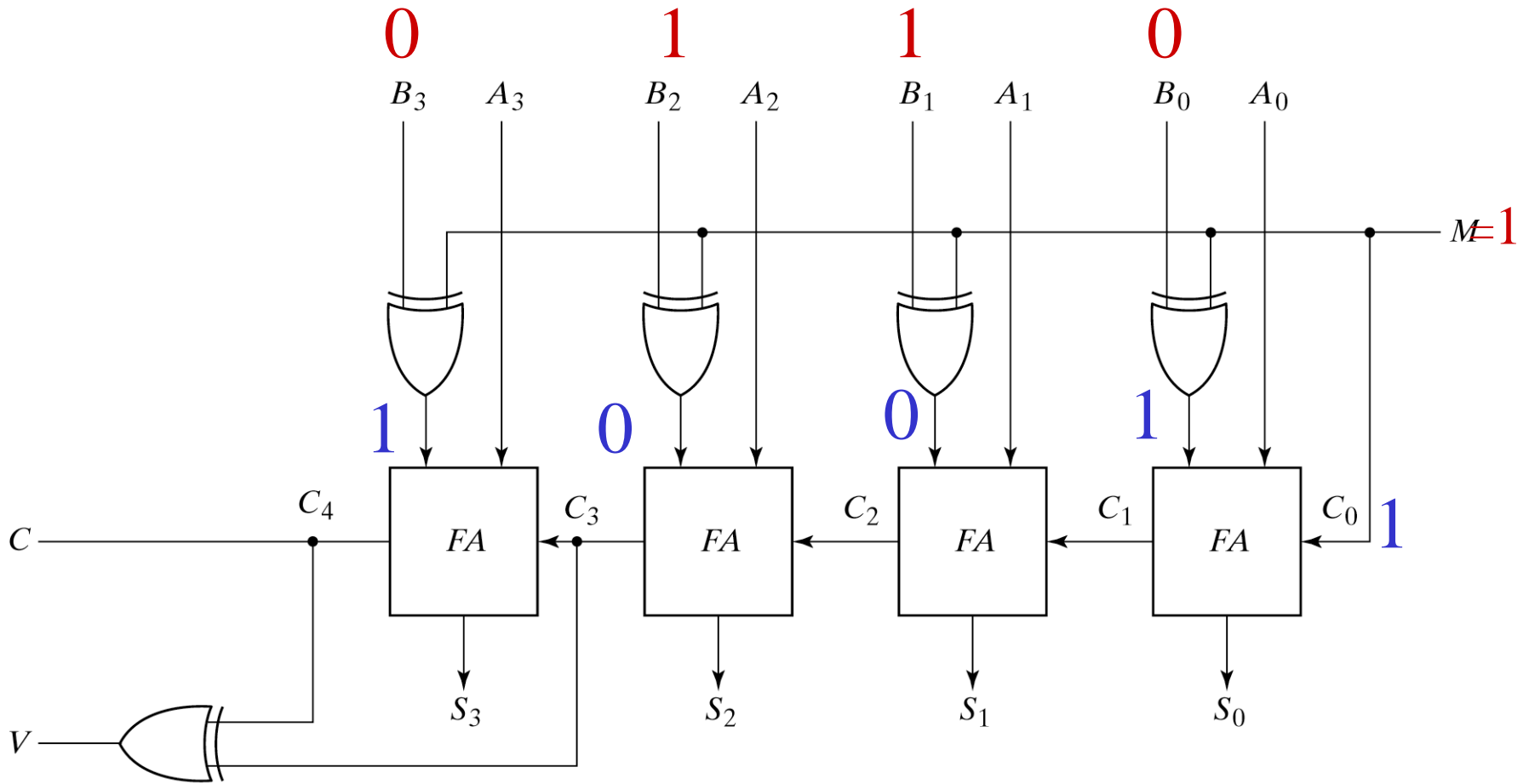

Fig. 4-13 4-Bit Adder Subtractor

SOP & POS Standard Forms- Example

From an arbitrary Truth table (next slide)

- **Part one**

- 1- obtain SOP representation for F

- 2- obtain the two level implementation for F without simplification

- 3- simplify F using Boolean identities

- 4- obtain two level-implementation for F

- 5- compare the design obtained in question 4 with the one of question 2

- **Part two**

Repeat part one using POS

Deriving SOP and POS from a truth table

Consider the following arbitrary Truth Table

i) SOP

ii) POS

i	A	B	C	F	Minterms
0	0	0	0	0	
1	0	0	1	0	
2	0	1	0	1	$\rightarrow m_2 = A'BC'$
3	0	1	1	1	$\rightarrow m_3 = A'BC$
4	1	0	0	0	
5	1	0	1	1	$\rightarrow m_5 = AB'C$
6	1	1	0	0	
7	1	1	1	1	$\rightarrow m_7 = ABC$

Deriving SOP from a truth table

1- Expression sum of products

$$\begin{aligned} \text{a) } F &= m_2 + m_3 + m_5 + m_7 \\ &= A'BC' + A'BC + AB'C + ABC \end{aligned}$$

b) Implementation with logic gates (unsimplified)

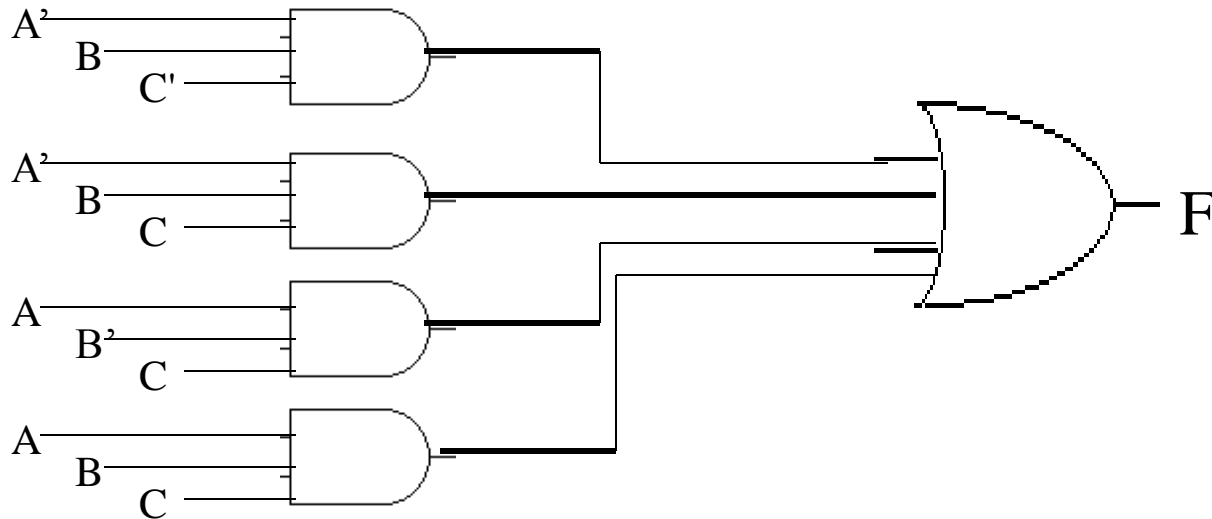

Two level-Implementation

Simplifying SOP using Boolean identities

c) Simplification

Using the Boolean identity absorption $xy + xy' = x$

We can simplify m_2 with m_3 and m_5 with m_7

$$m_2 + m_3 = (A'B)C' + (A'B)C = A'B$$

$$m_5 + m_7 = (AC)B' + (AC)B = AC$$

Therefore **$F = A'B + AC$**

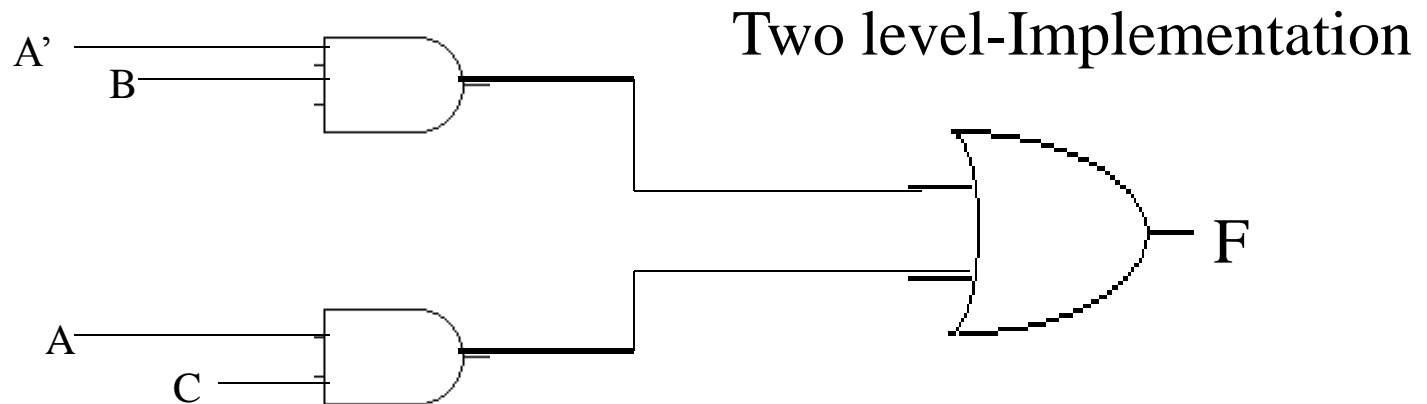

Circuit with 3 gates instead of 5

Deriving POS from a truth table

2- Expression Product of sums

i	A	B	C	F	Maxterms
0	0	0	0	0	$\rightarrow M_0 = A+B+C$
1	0	0	1	0	$\rightarrow M_1 = A+B+C'$
2	0	1	0	1	
3	0	1	1	1	
4	1	0	0	0	$\rightarrow M_4 = A'+B+C$
5	1	0	1	1	
6	1	1	0	0	$\rightarrow M_6 = A'+B'+C$
7	1	1	1	1	

Deriving SOP from a truth table

a) Function

$$F = M_0 \cdot M_1 \cdot M_4 \cdot M_6$$

$$= (A+B+C) (A+B+C')(A'+B+C)(A'+B'+C)$$

Logic circuit

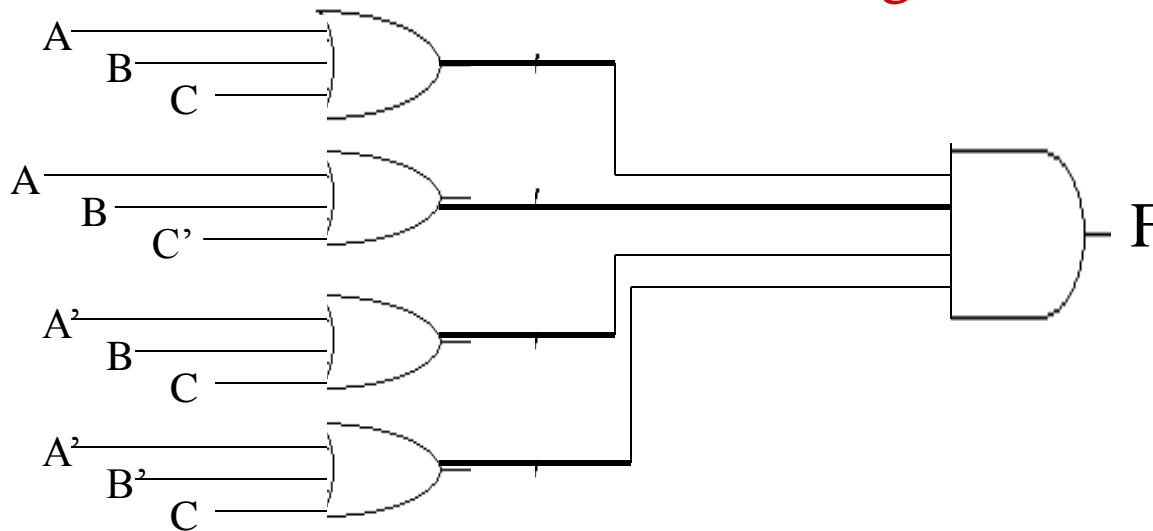

Two level-Implementation

Simplifying POS using Boolean identities

b) Simplification

Using $(X + Y) (X+Y') = X$

Verification

X	Y	Y'	X+ Y	X + Y'	(X + Y) (X+Y')
0	0	1	0	1	0
0	1	0	1	0	0
1	0	1	1	1	1
1	1	0	1	1	1

$$M0.M1 = [(A+B) + C] [(A+B) + C'] = \mathbf{A+B}$$

$$M4.M6 = [A' + C) + B] [(A'+C) + B'] = \mathbf{A'+C}$$

$$\mathbf{F = (A+B)(A'+C)}$$

Simplifying POS using Boolean identities

C) Two level Implementation

