

ASSIGNMENT 9

Quantum Physics
Bohr's Atom
Quantum mechanics and Pauli
Nuclear Decays
Particle Physics

UNIVERSITY OF OTTAWA
Principles of Physics
PHY1322 Winter 2018
Dr. A. Czajkowski

Principle

Assigned Wed Mar 28 Due: Mon April 9th 10:00PM 90 points total

SOLVE THE FOLLOWING PROBLEMS AND **ENTER ALL THE ANSWERS** USING THE ONLINE TEMPLATES:

ASSIGNMENT 9 ANSWERS PART I

ASSIGNMENT 9 ANSWERS PART II

ASSIGNMENT 9 ANSWERS PART III

PLEASE PAY ATTENTION TO THE REQUIRED PRECISION OF ALL OF THE ANSWERS.

DO NOT ATTEMPT TO ENTER THE UNITS!

PART II Each answer is worth 3 points

- 1 The first unmanned probe will reach the stellar system of the Alfa Centauri (estimated radius 5×10^4 km) in year 2145. The probe will enter stationary orbit of radius $R = 300 \times 10^6$ km. around the star. In order to power itself the probe will convert the radiative energy received by its 10 m^2 antenna. It is estimated that when oriented at a right angle with respect to the incoming radiation, the antenna will collect 30000W of total radiative power.

From given information one may infer that the λ_{max} , wavelength for which the Alfa Centauri emits the most energy is _____ nm. STATE YOUR ANSWER TO THE NEAREST NANOMETER.

ANS1:

- 2 Molybdenum has a work function of 4.20 eV. Find the cutoff wavelength for the photoelectric effect. (STATE YOUR SANSWER TO THE NEAREST NANOMETER):

ANS 2:

- 3 Magnesium has a work function of 3.66 eV. What is the stopping potential if the incident light has a wavelength of 180 nm? (STATE YOUR SANSWER TO THE NEAREST HUNDREDTH OF VOLT):

ANS 3:

- 4 An isolated copper sphere of radius 3.00 cm, initially uncharged, is illuminated by ultraviolet light of wavelength 190 nm. What charge will the photoelectric effect induce on the sphere? The work function for copper is 4.70 eV. (STATE YOUR SANSWER TO THE NEAREST HUNDREDTH OF pC):

ANS 4:

- 5 A 0.110-nm photon collides with a stationary electron. After the collision, the electron moves forward and the photon recoils backward. Find the kinetic energy of the electron after the collision. (STATE YOUR SANSWER TO THE NEAREST eV):

ANS 5:

- 6 X-rays having an energy of 300 keV undergo Compton scattering from a target. The scattered rays are detected at 37.0° relative to the incident rays. Find the energy of the recoiling electron. (STATE YOUR SANSWER TO THE NEAREST keV):

ANS 6:

7. The neutron has a mass of 1.67×10^{-27} kg. Neutrons emitted in nuclear reactions can be slowed down via collisions with matter. They are referred to as thermal neutrons once they come into thermal equilibrium with their surroundings. The average kinetic energy ($3k_B T/2$) of a thermal neutron is approximately 0.04 eV. Calculate the de Broglie wavelength of a neutron with a kinetic energy of 0.040 0 eV. STATE YOUR ANSWER TO THE NEAREST THOUSANDTH OF NANOMETER):

ANS7:

8. In the Davisson–Germer experiment, 54.0-eV electrons were diffracted from a nickel lattice. If the first maximum in the diffraction pattern was observed at $\varphi = 50.0^\circ$, what was the lattice spacing a between the vertical rows of atoms in the figure? (It is not the same as the spacing between the horizontal rows of atoms.)

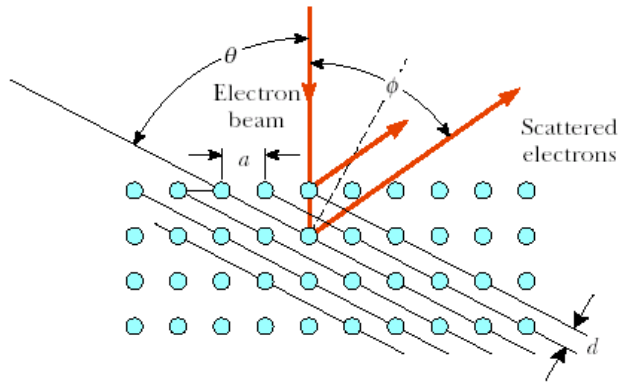

STATE YOUR ANSWER TO THE NEAREST THOUSANDTH OF NANOMETER:

ANS8:

9. How much energy is required to ionize hydrogen when it is in the ground state? State your answer to the nearest tenth of eV.
- ANS 9 :
10. How much energy is required to ionize hydrogen when it is in the state for which $n = 3$? State your answer to the nearest hundredth of eV.

ANS 10:

PART II Each answer is worth 3 points

11. If you wish to produce 10.0-nm x-rays in the laboratory, what is the minimum voltage you must use in accelerating the electrons?

State your answer to the nearest Volt.

ANS11:

12. **LENINGRAD, 1930**—Four years after publication of the Schrödinger equation, Lev Davidovich Landau, age 23, solved the equation for a charged particle moving in a uniform magnetic field. A single electron moving perpendicular to a field \mathbf{B} can be considered as a model atom without a nucleus, or as the irreducible quantum limit of the cyclotron. Landau proved that its energy is quantized in uniform steps of $e\hbar B/m_e$. **HARVARD, 1999**—Gerald Gabrielse traps a single electron in an evacuated centimeter-size metal can cooled to a temperature of 80 mK. In a magnetic field of magnitude 5.26 T, the electron circulates for hours in its lowest energy level, generating a measurable signal as it moves.

(a) Evaluate the size of a quantum jump in the electron's energy.

State your answer to the nearest micro electronVolt.

ANS12 :

(b) For comparison, evaluate $k_B T$ as a measure of the energy available to the electron in blackbody radiation from the walls of its container.

State your answer to the nearest micro electronVolt.

ANS13:

13. A living specimen in equilibrium with the atmosphere contains one atom of ^{14}C (half-life = 5 730 yr) for every 7.7×10^{11} stable carbon atoms. An archeological sample of wood (cellulose, $\text{C}_{12}\text{H}_{22}\text{O}_{11}$) contains 21.0 mg of carbon. When the sample is placed inside a shielded beta counter with 88.0% counting efficiency, 837 counts are accumulated in one week. Assuming that the cosmic-ray flux and the Earth's atmosphere have not changed appreciably since the sample was formed, find the age of the sample.

Round your answer to the nearest 10 years

ANS14:

15. A certain African artifact is found to have a carbon-14 activity of (0.12 ± 0.01) Bq per gram of carbon. Assume the uncertainty is negligible in the half-life of ^{14}C (5 730 yr) and in the activity of atmospheric carbon (0.25 Bq per gram). The age of the object lies within what range?

Round your answer to the nearest 100 years

ANS 15 : min:

ANS 16 : max:

16. After the sudden release of radioactivity from the Chernobyl nuclear reactor accident in 1986, the radioactivity of milk in Poland rose to 2 000 Bq/L due to iodine-131 present in the grass eaten by dairy cattle. Radioactive iodine, with half-life 8.04 days, is particularly hazardous, because the thyroid gland concentrates iodine. The Chernobyl accident caused a measurable increase in thyroid cancers among children in Belarus. (a) For comparison, find the activity of milk due to potassium. Assume that one liter of milk contains 2.00 g of potassium, of which 0.011 7% is the isotope ^{40}K with a half-life 1.28×10^9 yr. (b) After what elapsed time would the activity due to iodine fall below that due to potassium?

Round your answers to nearest(a) Bq; and (b) day

ANS17:

ANS18:

17

Europeans named a certain direction in the sky as between the horns of Taurus the Bull. On the day they named as July 4, 1054 A.D., a brilliant light appeared there. Europeans left no surviving record of the supernova, which could be seen in daylight for some days. As it faded it remained visible for years, dimming for a time with the 77.1-day half-life of the radioactive cobalt-56 that had been created in the explosion.

(a) The remains of the star now form the Crab nebula (see page 1066). In it, the cobalt-56 has now decreased to what fraction of its original activity?

(b) Suppose that an American, of the people called the Anasazi, made a charcoal drawing of the supernova. The carbon-14 in the charcoal has now decayed to what fraction of its original activity?

a) State your answer in the form of the integer exponent of 10 so if the result is $10^{-39.7}$ your answer is: -40
ANS19 :

b) state your answer to nearest one thousandth.
ANS20 :

PART III

Fill The Blanks To Obtain Correct Statements.

One number corresponds to one word! Each answer is worth 1 point

According to standard model the most fundamental constituents of matter are: six 1, that combine to form hadrons, six 2, and four 3 4, mediating the fundamental interactions.

The fundamental interactions in the order of increasing strength are: 5, 6, 7, 8

The 9 hypothesis put forward by Gell-Mann, met with initial skepticism because
(i) it would require existence of particles with 10 electric charge which have never been detected,
(ii) it might lead to violation of 11 12 principle.

The (i) objection was dealt with by introducing the concept of 13 according to which quarks can not be separated from inside of hadrons.

The (ii) objection was dealt with, by introduction of new quantum number called: 14.

Based on their spin all particle maybe divided into two groups: 15 and 16.

All leptons are 17 with their wave-functions 18 under the particle interchange operation, while 19 wave functions are 20 under the same operation. As result the 21 obey Pauli Exclusion Principle.

Initially based on their masses all particles could be grouped in the three major groups: lightweight 22, medium weight 23, and heavy 24.

In this group only 25 are the only truly elementary particles.

All 26 are made of 27 quarks while all 28 are made of single 29 and single 30.