

## ECOR 2606 Lab Test #2 v1

**Instructions:** Submit two "script" files, one for each of the two questions. Call these files Q1.m and Q2.m. All values output by your scripts must be appropriately identified (e.g. "The value of ... is ..."). Just omitting the semi-colon from the command that calculates the value is not acceptable. If a "script" requires functions that cannot be implemented as anonymous functions you must use a "void" (i.e. no inputs, no outputs) function m-file with secondary functions. A brief reminder of how to do this can be found on the G:drive (scripts.pdf).

1/. (6 marks) Analysis of an engineering problem has produced the system of equations shown below.  $Y$  is a parameter that can be varied.

$$\begin{aligned}(5 - Y)x_1 - 4x_2 + 4x_3 &= 1 \\ -5x_1 + (4 + Y)x_2 + 3x_3 &= 4 \\ 5x_1 + 3x_2 + (1 + Y)x_3 &= -2\end{aligned}$$

- (i) If  $Y$  is zero, what are  $x_1$ ,  $x_2$ , and  $x_3$ ?
- (ii) Create a plot of  $x_1$  vs  $Y$  for  $Y$  from 0 to 12
- (iii) Within this interval, what value of  $Y$  minimizes  $x_1$ ? What is the minimum value of  $x_1$ ?

2/. (4 marks) The crane illustrated below consists of a three element truss mounted on a base.

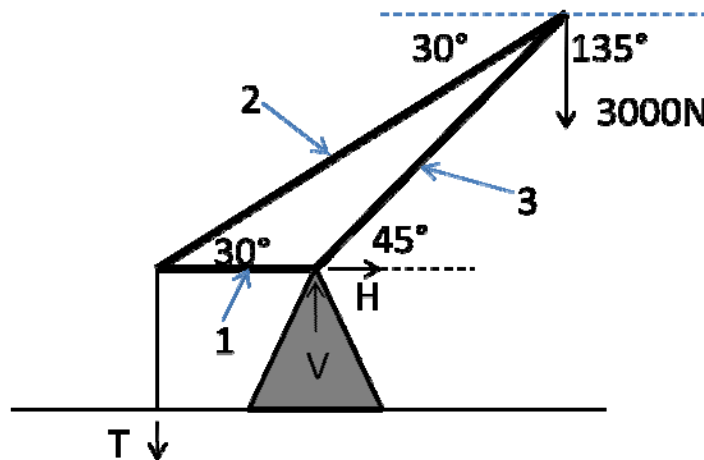

What are the tensions in each of the three truss members, the tension  $T$  in the guy wire, and the horizontal and vertical reactions ( $H$  and  $V$ ) at the support point? Use the numbers shown (1, 2, 3) to identify the truss members.