

**Question 1 (25 marks)**

Determine the magnitudes of the components of  $F$  acting along and perpendicular to segment  $BC$  of the pipe assembly.

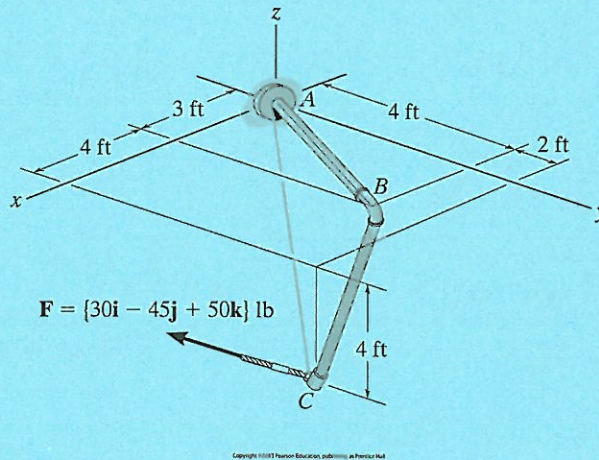

Unit vector for  $BC$ , 
$$\vec{U}_{BC} = \frac{\vec{r}_{BC}}{|\vec{r}_{BC}|}$$

$B = (3, 4, 0)$

$C = (7, 6, -4)$

$$\vec{U}_{BC} = \frac{4\hat{i} + 2\hat{j} - 4\hat{k}}{\sqrt{16 + 4 + 16}} = \frac{4}{6}\hat{i} + \frac{2}{6}\hat{j} - \frac{4}{6}\hat{k}$$

$$= \underline{\underline{0.66\hat{i} + 0.33\hat{j} - 0.66\hat{k}}}$$

$$\vec{F} = \{30\hat{i} - 45\hat{j} + 50\hat{k}\} \text{ lb}$$

Magnitude of component of force along segment  $BC$

$$\vec{F}_{BC} = \vec{F} \cdot \vec{U}_{BC}$$

$$= 30 \times \frac{4}{6} + \left(-45 \times \frac{2}{6}\right) + \left(50 \times -\frac{4}{6}\right)$$

$$= 20 - 15 - 33.33 = \underline{\underline{-28.33 \text{ lb}}}$$

10

Magnitude of  $\perp$ r component of force

$$|\vec{F}_n| = \sqrt{|\vec{F}|^2 - |F_{Bc}|^2}$$

$$= \sqrt{(73.654)^2 - (28.33)^2}$$

$$= \underline{\underline{67.99 \text{ lb}}}$$

$$|\vec{F}| = \sqrt{(30)^2 + (45)^2 + (50)^2}$$

$$= \underline{\underline{73.654 \text{ lb}}}$$

$$|F_{Bc}| = \sqrt{(-18.88)^2 + (9.44)^2 + (18.88)^2}$$

OR

$$|F_{Bc}| = 28.33 \text{ lb}$$

5

**Question 2 (25 marks)**

Replace the loading on the frame by a single resultant force. Specify where its line of action intersects member AB, measured from A.

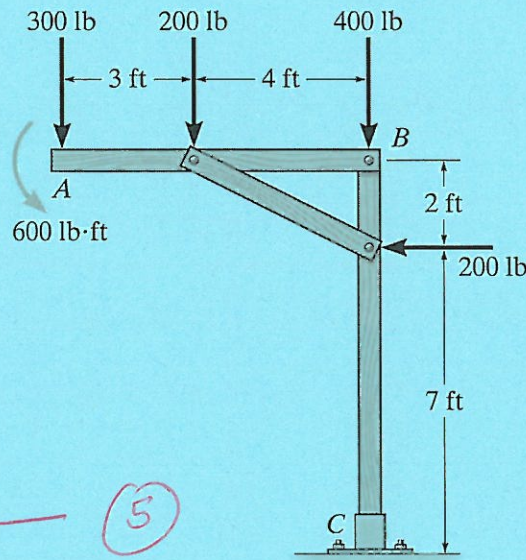

$$\Sigma F_x = -200 \text{ lb} \quad \text{--- (5)}$$

$$\Sigma F_y = -300 - 200 - 400 = -900 \text{ lb} \quad \text{--- (5)}$$

$$F_R = \sqrt{(F_x)^2 + (F_y)^2} = \sqrt{850000} = \underline{\underline{921.954 \text{ lb}}}$$

$$\tan \theta = \frac{F_y}{F_x} = \frac{900}{200} = 4.5$$

$$\theta = \tan^{-1}(4.5) = \underline{\underline{77.471^\circ}}$$

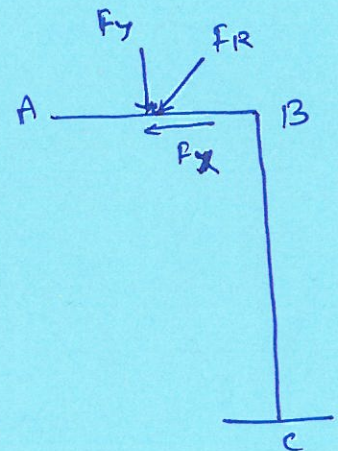

$$M_A \text{ by resultant force} = 900 \times x \text{ lb ft}$$

$$M_A \text{ by applied forces} = 300 \times 0 + 200 \times 3 + 400 \times 7 \\ + 200 \times 2 - 600$$

$$= 3200 \text{ lb ft}$$

Equating both

$$900 x = 3200$$

$$\Rightarrow x = \underline{\underline{3.55 \text{ m}}}$$

10

**Question 3 (25 marks)**

Determine the magnitude of the moment of the force  $F = 95i - 200j + 150k$  N about the  $OA$  axis.

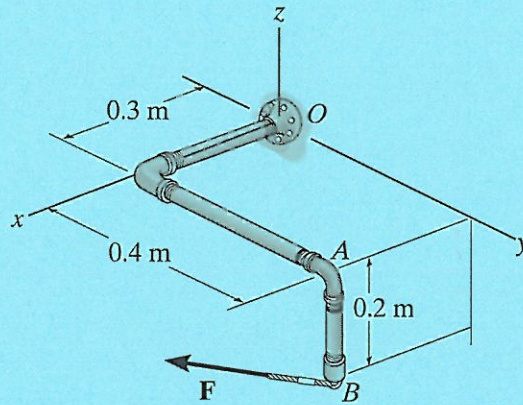

$$A(0.3, 0.4, 0)$$

$$B(0.3, 0.4, -0.2)$$

$$\vec{r}_{AB} = (0.3 - 0.3)\vec{i} + (0.4 - 0.4)\vec{j} + (-0.2 - 0)\vec{k} = -0.2\vec{k}$$

$$\vec{r}_{OA} = 0.3\vec{i} + 0.4\vec{j}$$

$$\vec{u}_{OA} = \frac{\vec{r}_{OA}}{|\vec{r}_{OA}|} = \frac{0.3\vec{i} + 0.4\vec{j}}{\sqrt{0.3^2 + 0.4^2}} = \frac{0.3\vec{i} + 0.4\vec{j}}{0.5} = 0.6\vec{i} + 0.8\vec{j}$$

10

$$M_{OA} = \vec{u}_{OA} \cdot (\vec{r}_{AB} \times \vec{F})$$

$$= (0.6\vec{i} + 0.8\vec{j}) \cdot [-0.2\vec{k} \times (95\vec{i} - 200\vec{j} + 150\vec{k})]$$

$$= (0.6\vec{i} + 0.8\vec{j}) \cdot (-19\vec{j} - 40\vec{i} + 0\vec{k})$$

$$= 0.6(-40) + 0.8(-19)$$

$$M_{OA} = -39.2 \text{ Nm}$$

15

**Question 1 (25 marks)**

Determine the magnitudes of the components of  $F = 600\text{ N}$  acting along and perpendicular to segment  $DE$  of the pipe assembly.

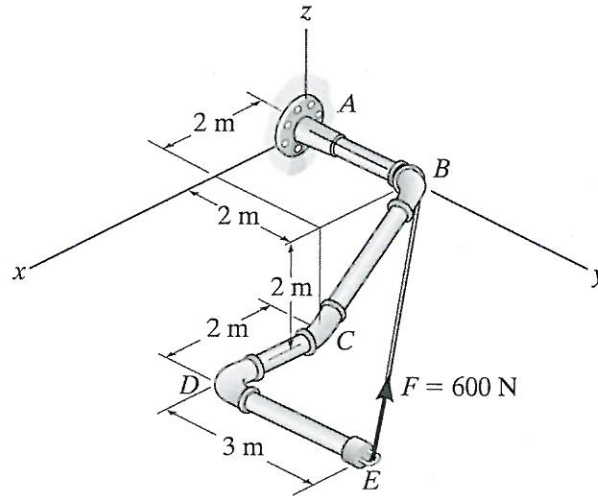

Unit vector for DE,  $\vec{U}_{DE} = \frac{\vec{r}_{DE}}{|\vec{r}_{DE}|}$

$D = (4, 2, -2)$

$E = (4, 5, -2)$

$\vec{r}_{DE} = 0\hat{i} + 3\hat{j} + 0\hat{k}$

$\vec{U}_{DE} = \frac{3\hat{j}}{3} = \underline{\underline{\hat{j}}}$

$F = 600\text{ N}$

unit vector along the force,  $\vec{U}_{EB} = \frac{\vec{r}_{EB}}{|\vec{r}_{EB}|}$

$$B = (0, 2, 0)$$

$$\begin{aligned}\vec{U}_{EB} &= \frac{-4\hat{i} + -3\hat{j} + 2\hat{k}}{\sqrt{16+9+4}} = \frac{-4\hat{i} - 3\hat{j} + 2\hat{k}}{\sqrt{29}} \\ &= \underline{\underline{-0.742\hat{i} - 0.557\hat{j} + 0.371\hat{k}}}\end{aligned}$$

$$\begin{aligned}\vec{F} &= F \vec{U}_{EB} = \frac{-600 \times 4}{\sqrt{29}} \hat{i} - \frac{1800 \hat{j}}{\sqrt{29}} + \frac{1200}{\sqrt{29}} \hat{k} \\ &= \underline{\underline{-445.66 \hat{i} - 334.25 \hat{j} + 222.83 \hat{k}}}\end{aligned}$$

component along segment DE =  $\vec{F} \cdot \vec{U}_{DE}$

$$\begin{aligned}&= \frac{-2400}{\sqrt{29}} \times 0 - \frac{1800}{\sqrt{29}} \times 1 + \frac{1200}{\sqrt{29}} \times 0 \\ &= \frac{-1800}{\sqrt{29}} = \underline{\underline{-334.251 \text{ N}}}\end{aligned}$$

component  $\perp$  to DE

$$\begin{aligned}|\vec{F}_n| &= \sqrt{|\vec{F}|^2 - |\vec{F}_{DE}|^2} \\ &= \sqrt{(600)^2 - (-334.251)^2} \\ &= \underline{\underline{498.264 \text{ N}}}\end{aligned}$$

$$|\vec{F}| = 600$$

$$|\vec{F}_{DE}| = -334.251$$

**Question 2 (25 marks)**

Determine the magnitude of the moment of the force  $F = 100i - 200j + 55k$  N about the OA axis.

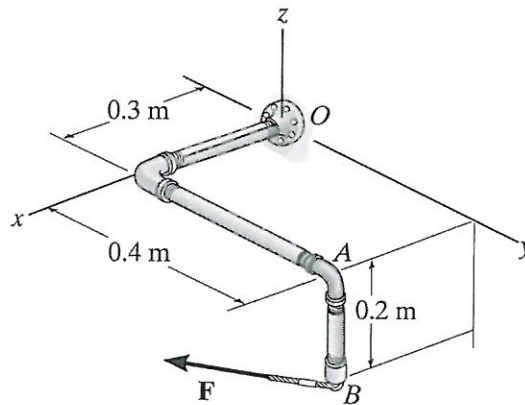

10

$$A(0.3, 0.4, 0.0)$$

$$B(0.3, 0.4, -0.2)$$

$$\vec{r}_{OA} = 0.3\vec{i} + 0.4\vec{j}$$

$$\vec{r}_{AB} = (0.3 - 0.3)\vec{i} + (0.4 - 0.4)\vec{j} + (-0.2 - 0.0)\vec{k}$$

$$= -0.2\vec{k}$$

$$\vec{u}_{OA} = \frac{\vec{r}_{OA}}{|\vec{r}_{OA}|} = \frac{0.3\vec{i} + 0.4\vec{j}}{\sqrt{0.3^2 + 0.4^2}} = \frac{0.3\vec{i} + 0.4\vec{j}}{0.5} = 0.6\vec{i} + 0.8\vec{j}$$

$$M_{OA} = \vec{u}_{OA} \cdot (\vec{r}_{AB} \times \vec{F})$$

$$= (0.6\vec{i} + 0.8\vec{j}) \cdot (-0.2\vec{k} \times (100\vec{i} - 200\vec{j} + 55\vec{k}))$$

$$= (0.6\vec{i} + 0.8\vec{j}) \cdot (-20\vec{j} - 40\vec{i} + 0\vec{k})$$

$$= 0.6(-40) + 0.8(-20)$$

$$M_{OA} = -40 \text{ Nm}$$

15

**Question 3 (25 marks)**

Replace the force system acting on the frame by an equivalent resultant force and specify where the resultant's line of action intersects member AB, measured from point A.

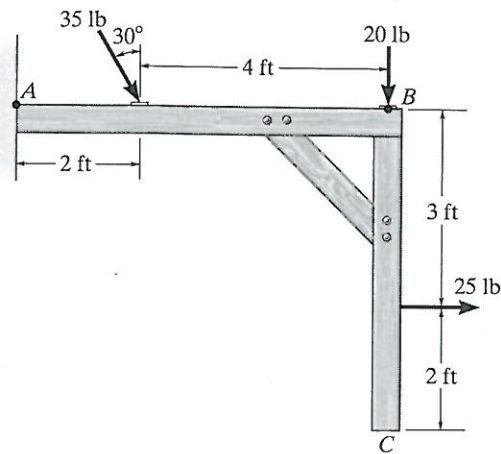

$$\begin{aligned} \sum F_x &= 35 \sin 30 + 25 \\ &= \underline{42.5 \text{ lb}} \end{aligned}$$

} (5)

$$\begin{aligned} \sum F_y &= 35 \cos 30 + 20 \\ &= \underline{50.310 \text{ lb}} \end{aligned}$$

} (5)

$$\begin{aligned} F_R &= \sqrt{(F_x)^2 + (F_y)^2} \\ &= \underline{65.85 \text{ lb}} \end{aligned}$$

} (5)

$$\tan \theta = \frac{50.310}{42.5} = 1.183$$

$$\theta = \tan^{-1}(1.183) = \underline{49.791^\circ}$$

$M_A$  due to resultant

$$= 50 \cdot 310 \times x \text{ lb ft}$$

$M_A$  due to other applied forces

$$= 35 \cos 30 \times 2 + 20 \times 6 - (25 \times 3)$$

$$= 60 \cdot 621 + 120 - 75$$

$$= \underline{\underline{105.62 \text{ lb ft}}}$$

Equating both moments

$$50 \cdot 310 \times x = 105.62$$

$$\Rightarrow x = \underline{\underline{2.099 \text{ m}}}$$

10