

Poll question: How much time did you spend studying for this exam over the past week? Round to the nearest hour and enter the number in the "EXAM NUMBER" section of the Scantron form. Example: 7 hours studying, enter "007" or 14 hours studying, enter "014"

Section 1: Multiple choice. Questions 1-31 must be answered on the Scantron form by shading the appropriate circle with blue or black pen or pencil. Scantron responses will be used to calculate your grade. Please indicate your answers on this examination paper in the event your Scantron is lost.

Note that **more than one letter** could be entered as an answer to a multiple choice question. Questions are not equally weighted in marks; it is **not 1 mark per answer**.

questions 1 to 5:

Consider the molecule (*Claritin, an antihistamine pharmaceutical*) to the right. Take note of the fact that specific atoms in this structure have been labelled **a** through **d**.

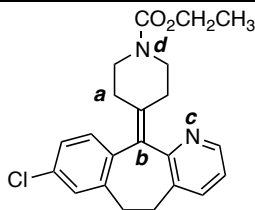

1) Indicate the hybridization of the carbon atom labeled **a**:

(A) s (B) p (C) sp (D) sp² (E) sp³ (F) σ (sigma) (G) π (pi)

2) Indicate the hybridization of the carbon atom labeled **b**:

(A) s (B) p (C) sp (D) sp² (E) sp³ (F) σ (sigma) (G) π (pi)

3) The non-bonded electron pair on the nitrogen atom labeled **c** resides in a _____ orbital:

(A) s (B) p (C) sp (D) sp² (E) sp³ (F) σ (sigma) (G) π (pi)

4) The non-bonded electron pair on the nitrogen atom labeled **d** resides in a _____ orbital.

(A) s (B) p (C) sp (D) sp² (E) sp³ (F) σ (sigma) (G) π (pi)

5) Claritin is a chiral molecule.

(A) true (B) false (D) do not have enough information to answer.

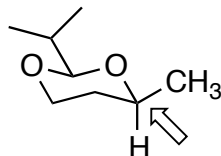

6) The configuration of the indicated stereogenic carbon atom is:

- (A) Z configuration
 (B) E configuration
 (C) R configuration
 (D) S configuration
 (E) L configuration
 (F) D configuration

7) This molecule features a _____ functional group:

- (A) carboxylic ester
 (B) sulfonic ester
 (C) cyclonic ester
 (D) cyclic acetal
 (E) cyclic ether
 (F) cyclic demilovatal
 (G) cyclic hemiether
 (H) lactone

• For questions 8)-14), select the letter (A, B, C, D) that corresponds to the arrows that *best* describes the relationship between the 'reactants' and 'products'. Be sure to fill in your Scantron!

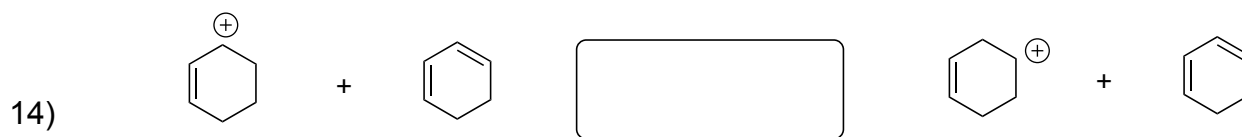
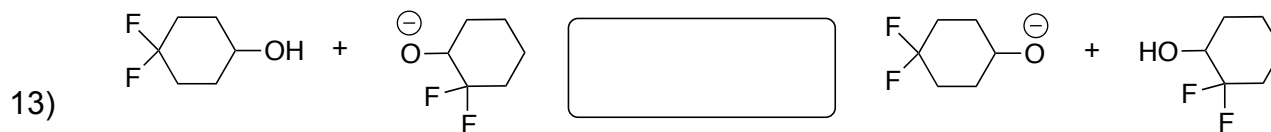
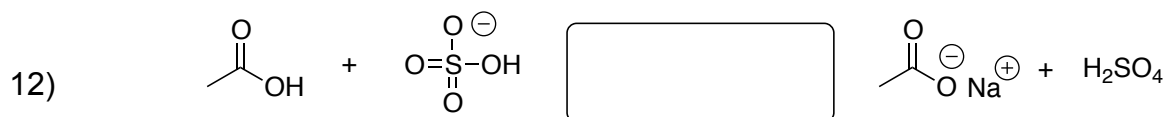
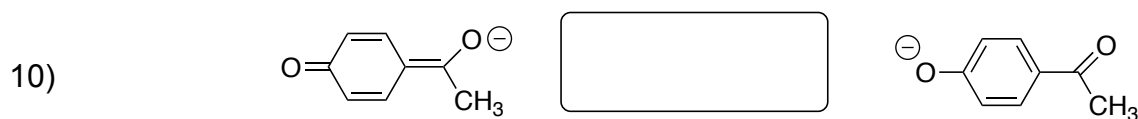
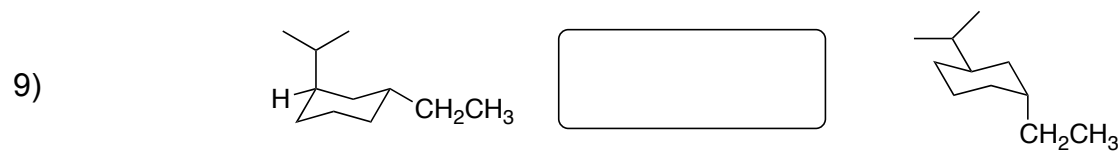
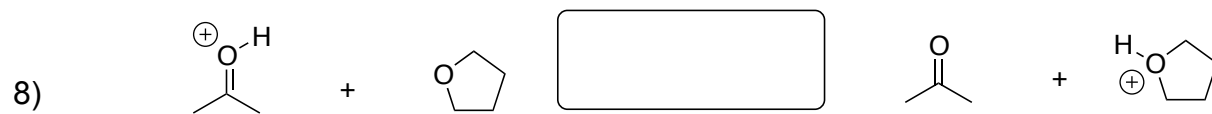
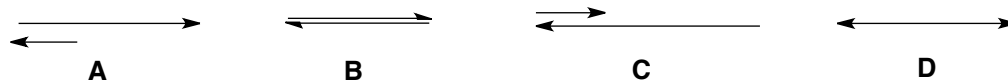

questions 15 to 17. Consider the reaction sequence below. Select all answers that apply. Take note that *incorrect selections will be subtracted from correct selections.*

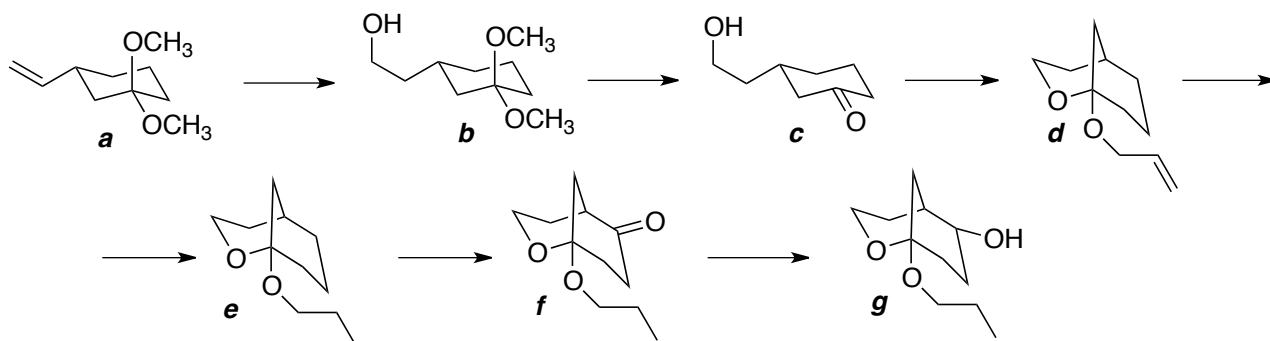

15) Which processes are classified as an oxidation?

- A) **a to b**
- B) **b to c**
- C) **c to d**
- D) **d to e**
- E) **e to f**
- F) **f to g**

16) Which processes are classified as a reduction?

- A) **a to b**
- B) **b to c**
- C) **c to d**
- D) **d to e**
- E) **e to f**
- F) **f to g**

17) Which compounds feature a secondary (2°) alcohol?

- A) **a**
- B) **b**
- C) **c**
- D) **d**
- E) **e**
- F) **f**
- G) **g**

questions 18 to 21: For each of the pairs of structures below, indicate whether each of these pairs are: **A**: identical compounds, **B**: constitutional isomers or **C**: different compounds that are not constitutional isomers.

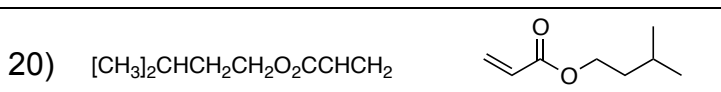
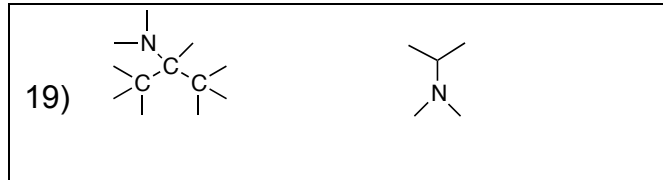
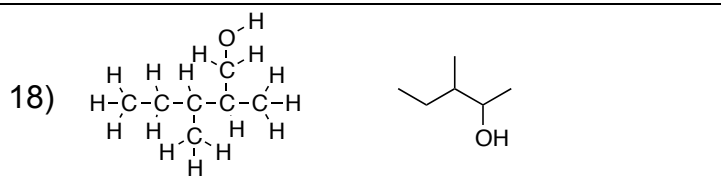

question 22:

Consider the series **A-G** on the right.

Indicate the species that have *aromatic character*. Note that incorrect selections will be subtracted from correct.

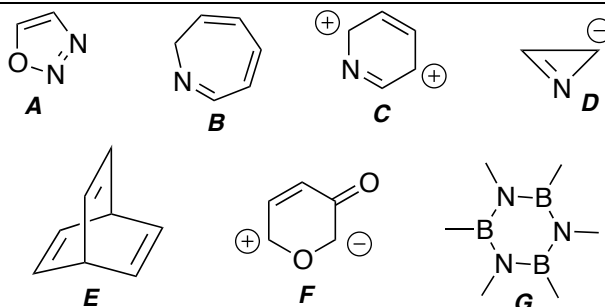

• Questions 23-25: Consider the compounds **2**, and **A-F** (below) when answering. More than one letter *may* be indicated in your answers. Take note that incorrect answers will be subtracted from correct answers.

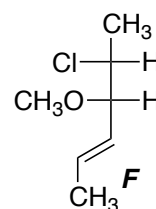
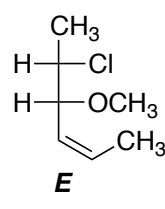
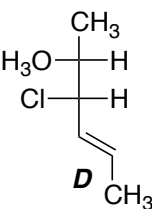
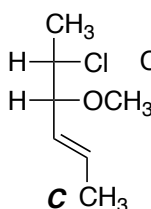
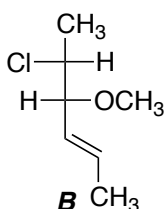
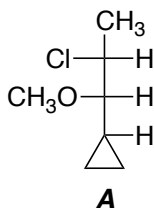
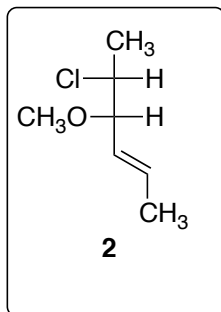

23) What compound(s) **A-F** is/are *enantiomer(s)* of compound **2**?

24) What compound(s) **A-F** is/are *constitutional isomer(s)* of compound **2**?

25) What compound(s) **A-F** is/are *diastereomer(s)* of compound **2**?

• Questions 26 to 31. Each of the following phrases is either:

(A) true

(B) false

(C) cannot be determined

26) The pK_A of a strong acid has a larger numerical value compared to the pK_A of a weak acid.

27) Mixtures of chiral molecules are always optically active.

28) Molecules that contain polar bonds must have a dipole moment.

29) Water has a (relatively) high boiling point because the O-H bond in water is relatively strong.

30) In terms of hydrogen bond interactions in DNA, a G-C base pair is stronger than a A-T base pair.

31) In the following reaction of an aldehyde, the product is a meso compound.

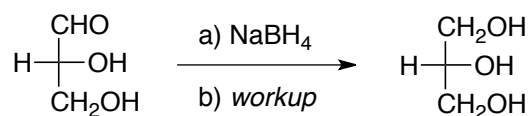

Section 2. Short answer questions. Please write your answers in the designated space. Please note that in some cases it is better for you to work out your answer on practice paper and copy a neat version to the examination paper.

****Messy and/or incoherent answers that are difficult to read or interpret may receive reduced or zero credit.****

2-1) (4 marks) Draw formal Lewis structures with all lone pairs and formal charges clearly shown.

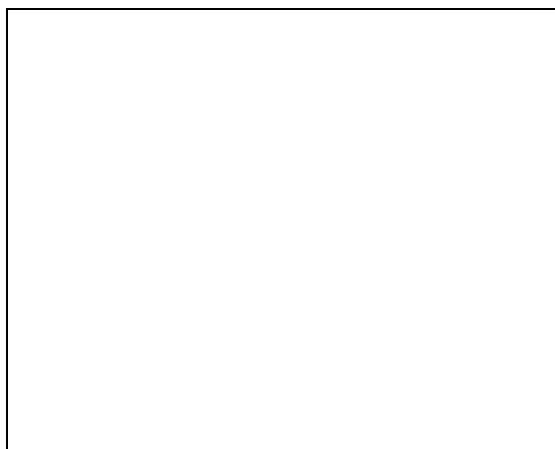

• diazene (HNNH)

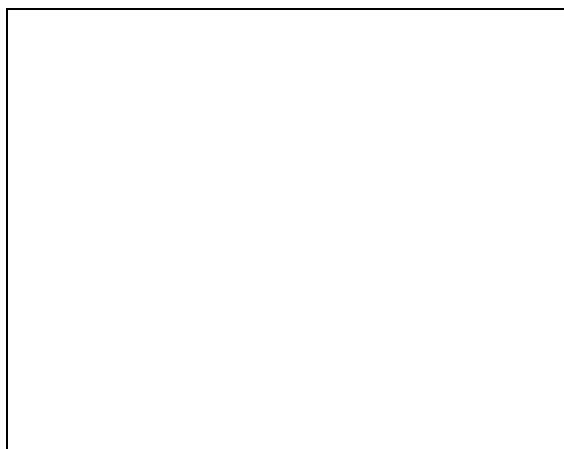

• conjugate acid of hydrogen peroxide
(H_3O_2^+)

2-2) (3 marks): Sketch the orbitals involved in the π -bonding framework of methanamide.



2-3) (3 marks) Using the supplied template, provide a *Fischer projection* for compound **3**:

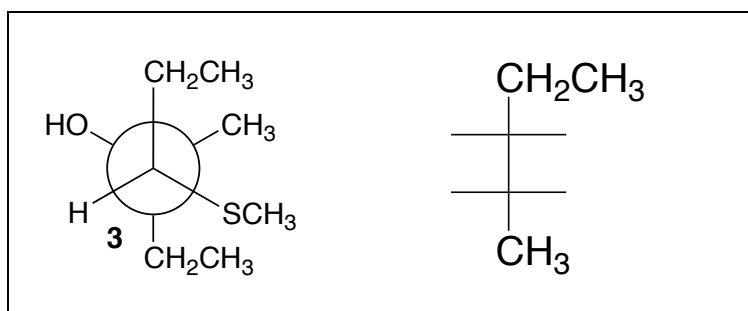

2-4) (6 marks) Draw the *major contributing resonance structures* for the following cation. Be sure to indicate electron movement using curved arrows between each structure in your sequence:

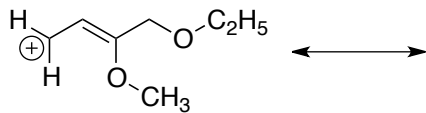

2-5) (4 marks) The gall bladder releases bile, a mixture of water, bile salts and other chemicals, to assist in the digestion of fatty foods. The structure of a bile salt is given. Describe how a bile salt assists to disperse fats into small droplets during digestion processes.

(note: pictures=1000 words)

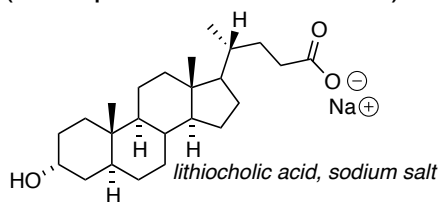

2-6) (4 marks) In the box, use curved arrows that represent electron movement to show bond-breaking and bond-forming events between two imaginary reactants that form the described products below.

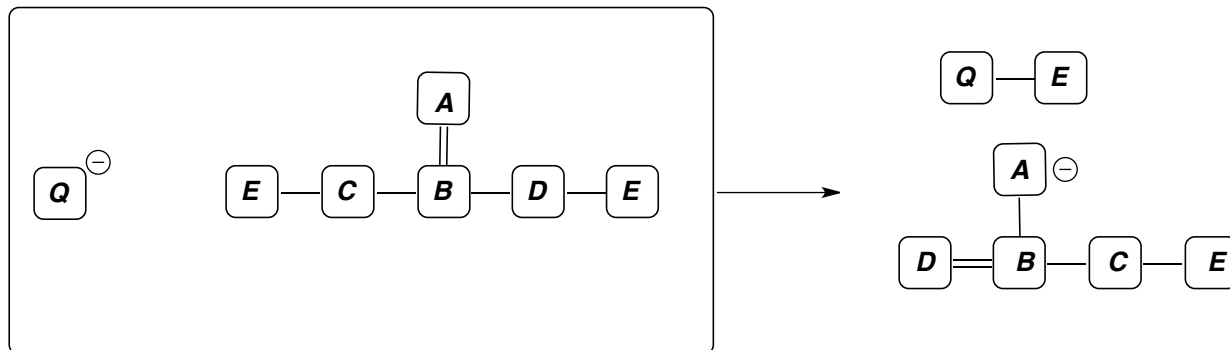

2-7) (4 marks) Circle the most acidic compound between compounds **a** and **b** below. Justify your selection with pictures accompanied by brief comments. Note that simply stating that one compound has a lower pK_A than the other will not receive credit!

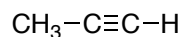

a

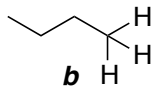

b

2-8) (4 marks) Circle the most acidic compound between compounds **c** and **d** below. Justify your selection with pictures accompanied by brief comments. Note that simply stating that one compound has a lower pK_A than the other will not receive credit!

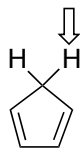

c

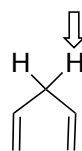

d

2-9) (3 marks) a) complete any formal charges on the structure below.
 b) You are given the curved arrow description of the reaction. Provide the product of this reaction.

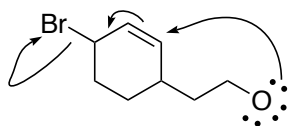

End of Exam Questions