

A4 - SOLUTION

Problem 1 (5 marks)

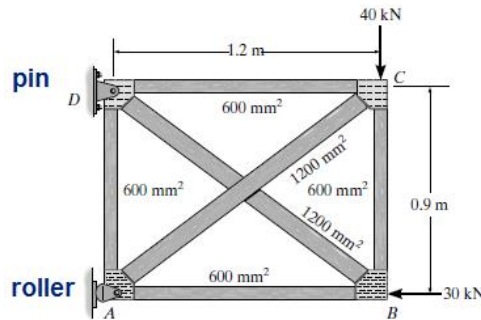

primary structure

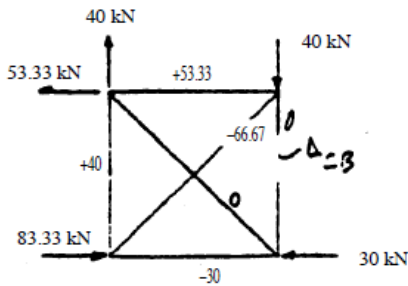

redundant structure

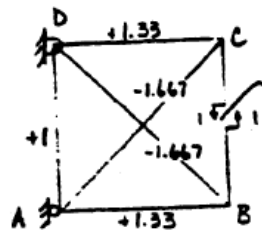

x R

R = N_{BC}

Setup a table with L_i , A_i , N_{oi} , n_i (not shown) ...

$$\Delta_{CB} = \sum \frac{nNL}{AE} = \frac{1}{600E} \left[\frac{(1.33)(53.33)(1.2)}{1} + \frac{(1.33)(-30)(1.2)}{1} + \frac{(1)(40)(0.9)}{1} \right] + \left[\frac{(-1.667)(-66.67)(1.5)}{2} \right]$$

$$= \frac{156.5}{600E}$$

$$f_{CBCB} = \sum \frac{n^2L}{AE} = \frac{1}{600E} \left[\frac{2(1.33)^2(1.2)}{1} + \frac{2(1)^2(0.9)}{1} + \frac{2(-1.667)^2(1.5)}{2} \right]$$

$$= \frac{10.23}{600E}$$

$$\Delta_{CB} + F_{CB}f_{CBCB} = 0$$

$$\frac{156.5}{600E} + F_{CB} \left(\frac{10.23}{600E} \right) = 0$$

$$F_{CB} = -15.289 \text{ kN} = 15.3 \text{ kN (C)}$$

Ans

To solve for member forces either use $F = No_i + R * n_i$ or do truss analysis as shown below (you should obtain the same results) ...

Joint C:

$$+ \uparrow \Sigma F_y = 0; \quad \frac{3}{5} F_{AC} - 40 + 15.3 = 0;$$

$$F_{AC} = 41.2 \text{ kN (C)}$$

Ans

$$\rightarrow \Sigma F_x = 0; \quad \frac{4}{5}(41.2) - F_{DC} = 0; \quad F_{DC} = 32.9 \text{ kN}$$

Ans

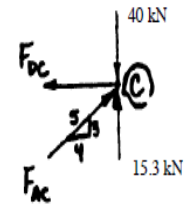

Joint B:

$$+ \uparrow \Sigma F_y = 0; \quad -15.289 + \left(\frac{3}{5}\right)(F_{DB}) = 0;$$

$$F_{DB} = 25.482 = 25.5 \text{ kN (T)}$$

Ans

$$\rightarrow \Sigma F_x = 0; \quad F_{AB} - 30 - 25.5\left(\frac{4}{5}\right) = 0;$$

$$F_{AB} = 50.4 \text{ kN (C)}$$

Ans

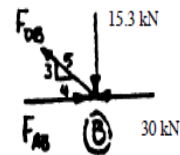

Joint A:

$$+ \uparrow \Sigma F_y = 0; \quad -41.2\left(\frac{3}{5}\right) + F_{DA} = 0;$$

$$F_{DA} = 24.7 \text{ kN (T)}$$

Ans

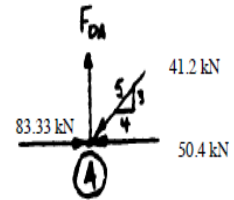

Problem 2 (5 marks)

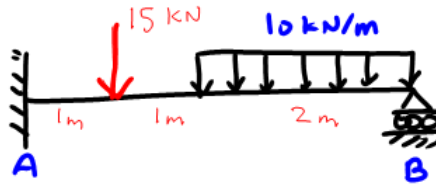

PRIMARY SYSTEM

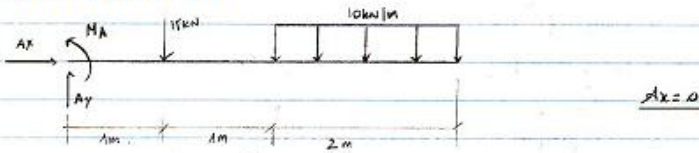

$$\sum F_y = 0 \rightarrow A_y - 15 - (10)(2) = 0 \rightarrow A_y = 35 \text{ kN}$$

$$\sum M_A = 0 \rightarrow M_A - 15 - (3)(10)(2) = 0$$

$$\rightarrow M_A = 75 \text{ kN}\cdot\text{m}$$

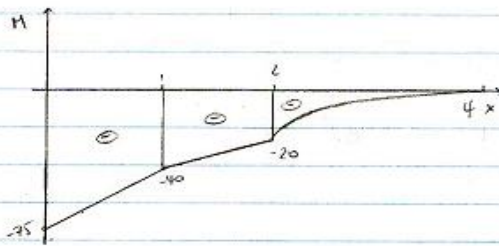
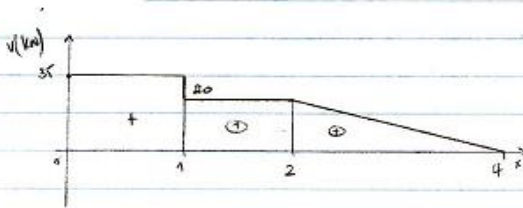

REDUNDANT SYSTEM

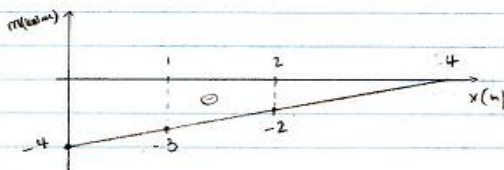
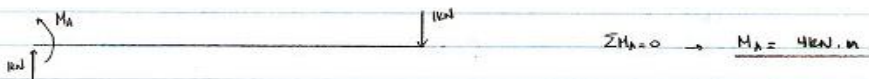

Let's find $\int \frac{mM}{EI} dx$

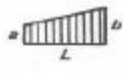

 $\frac{L}{6} (2ac + ad + 2bd + bc)$
 $= \frac{1}{6} [(2)(-71)(-4) + (-71)(-3) + (2)(-40)(-3) + (-40)(-4)]$

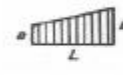

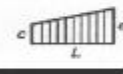
 $\frac{L}{6} (2ac + ad + 2bd + bc)$
 $= \frac{1}{6} [(2)(-40)(-3) + (-40)(-2) + (-20)(-3) + (2)(-20)(-2)]$

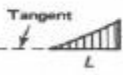



 $\frac{1}{4} Lbd$
 $= \frac{2}{4} (-20)(-2)$



$$\int \frac{mM}{EI} dx = 1805/(6EI)$$

Next we find $\int \frac{mm}{EI} dx \dots$

Now $\int \frac{mm}{EI} dx$



$$\int \frac{mm}{EI} dx = \frac{1}{EI} \left[\frac{4}{3} (4)^2 \right] = \frac{64}{3EI}$$

Now $\Delta_{total} = \frac{1805}{6EI} + (R) \frac{64}{3EI} = 0 \rightarrow R = -14.1 \text{ kN}$

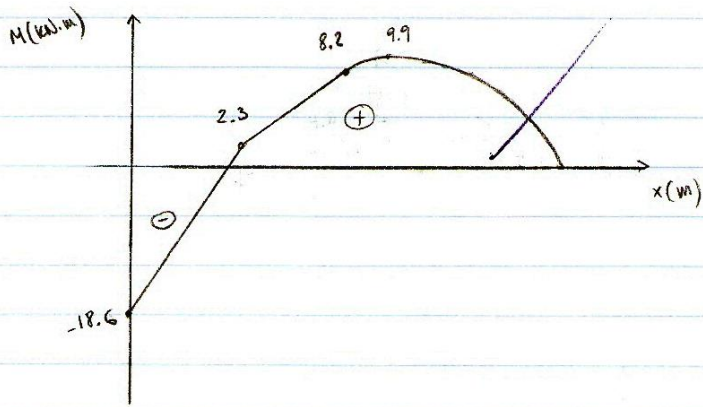
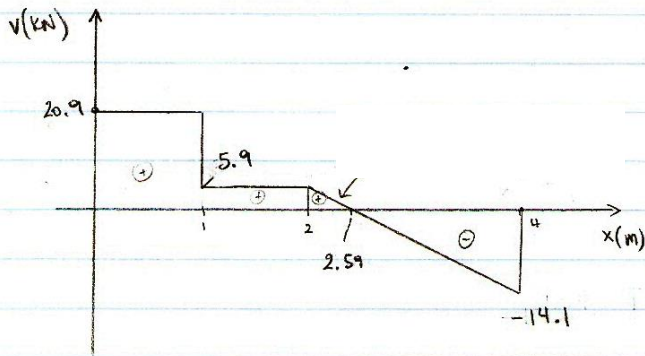
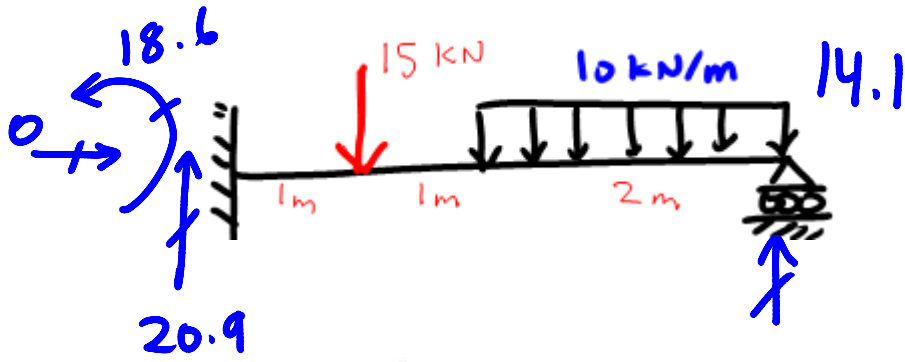

Problem 3 (10 marks)

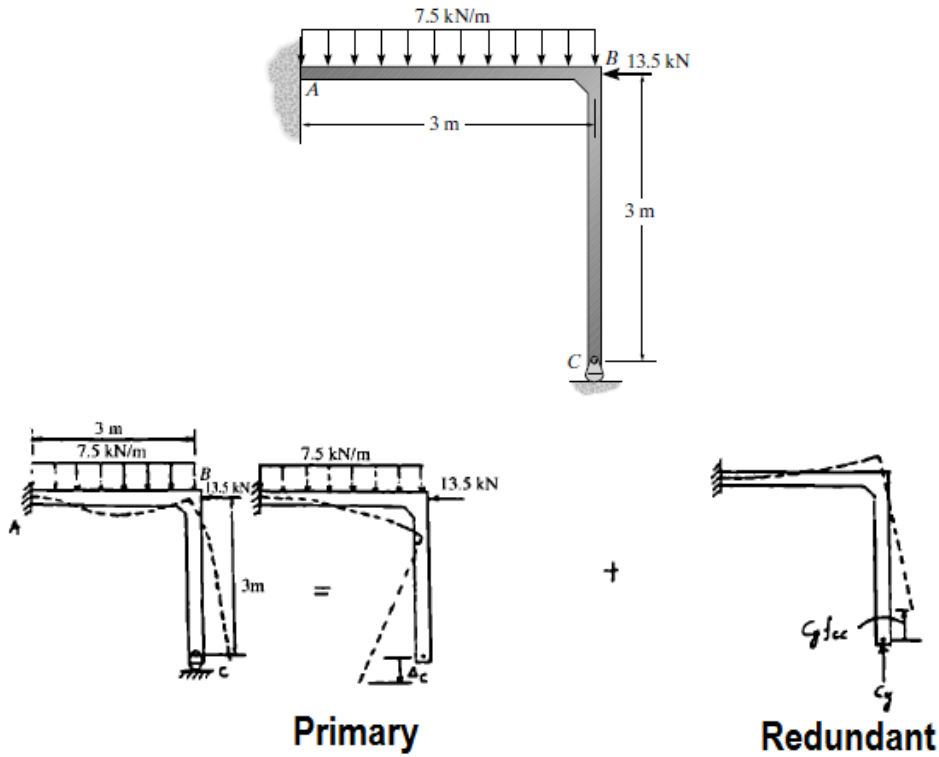

Compatibility Equation :

$$(+\downarrow) \quad 0 = \Delta_C - C_y f_{cc} \quad (1)$$

Use virtual work method :

$$\Delta_C = \int_0^L \frac{mM}{EI} dx = \text{using Mohr} = \frac{-75.94}{EI}$$

$$f_{cc} = \int_0^L \frac{mm}{EI} dx = \text{using Mohr} = \frac{9}{EI}$$

(note I am not showing the steps, please try yourself)

From Eq. (1) $0 = \frac{75.94}{EI} - \frac{9}{EI} C_y$

$C_y = 8.44 \text{ kN} \quad \text{Ans}$

$A_x = 13.5 \text{ kN} \quad \text{Ans}$

$A_y = 14.06 \text{ kN} \quad \text{Ans}$

$M_A = 8.44 \text{ kN} \cdot \text{m} \quad \text{Ans}$

Now you can draw shear and moment diagrams (not shown) ...