

ECOR 1010

Lecture 6

Engineering Graphics - 2

Standard Drawing Layout

- The standard arrangement for a technical drawing is a **three-view orthographic projection**:
 - Top view is located above front view
 - Right view is located to the right of front view
- The views must be aligned

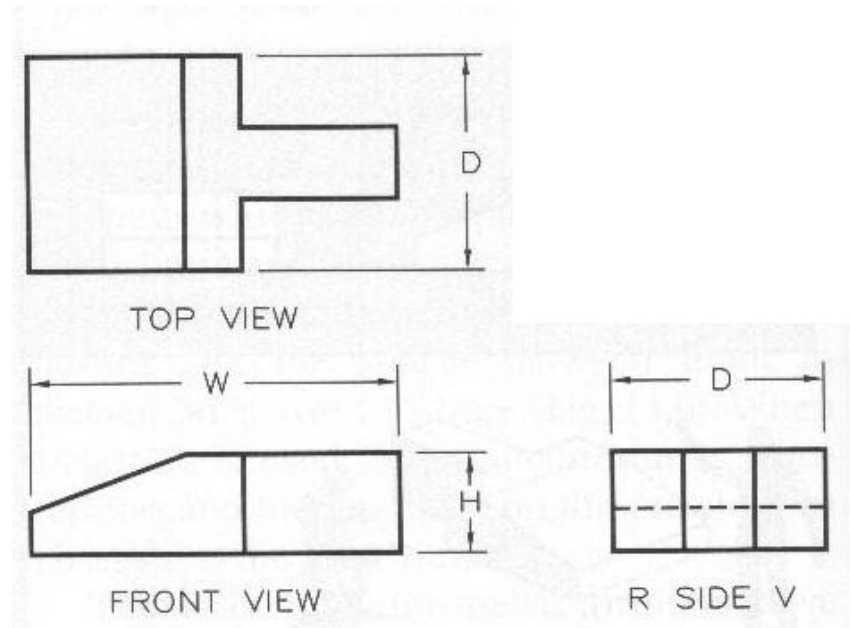

Orthographic Projection - Lines

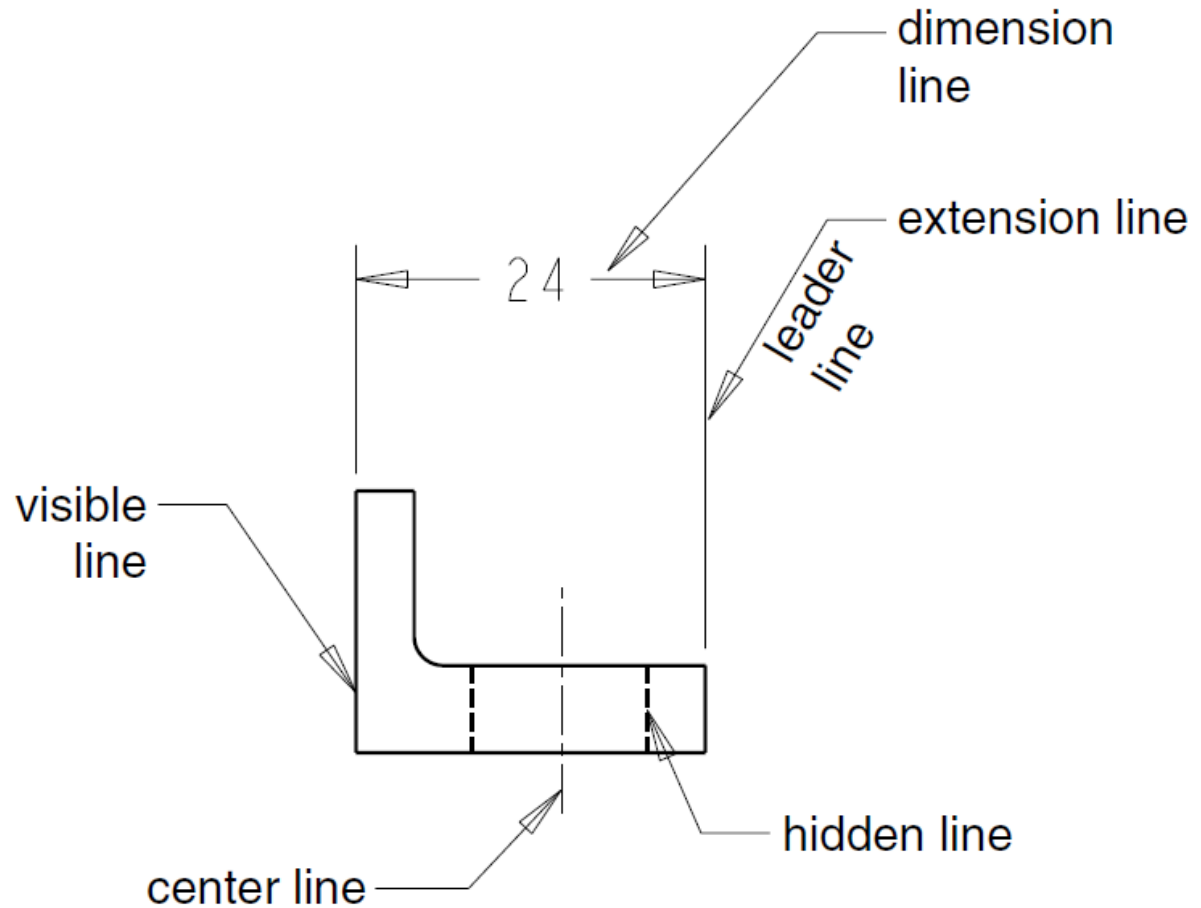
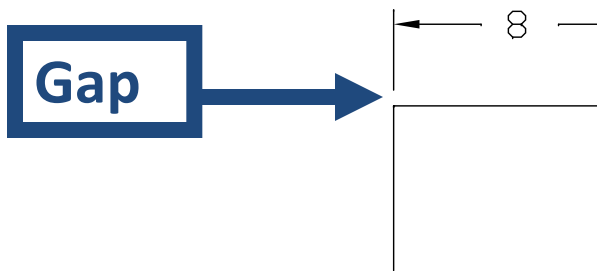

Figure 14.3 Types of lines used in drawings.

Extension and Centre Lines

- Conventions:
 - Leave a gap between the end of an extension line and the object to which it refers (a)
 - The short dashes of crossing perpendicular centre lines form a small cross (b)



(a)

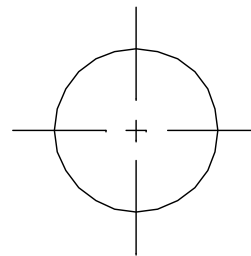

(b)

Orthographic Projection - Lines

- When two or more lines coincide, there is a convention called 'precedence of lines' to establish which is visible
 - Visible object lines
 - Hidden lines and cutting plane lines
 - Centre lines
 - Extension & leader lines

Line Types

- **Object Lines:** indicate all visible edges of an object; must stand out and be apparent to the eye
- **Hidden Lines:** shows object lines that are hidden from view
- **Cutting Plane Lines:** indicates edge view of an imaginary cutting plane
 - Define section views
- **Centre Lines:** indicates centres of holes and symmetrical features of an object

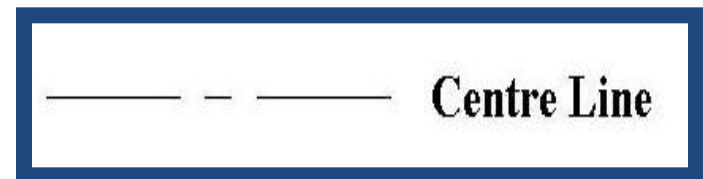
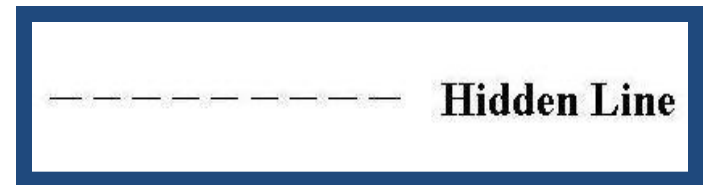

Line Type Precedence



VISIBLE LINE takes precedence over all other lines



HIDDEN LINE
and



CUTTING PLANE LINE

take precedence over center lines



CENTER LINE does not have precedence

Orthographic Projection - Lines

The hidden line of the bottom edge takes precedence over the centre line of the hole

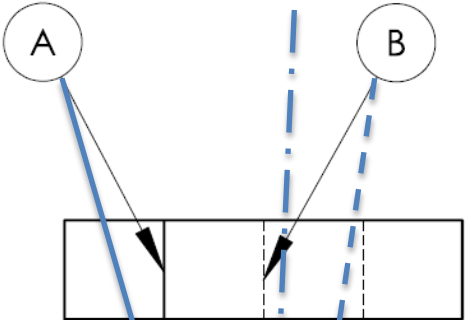
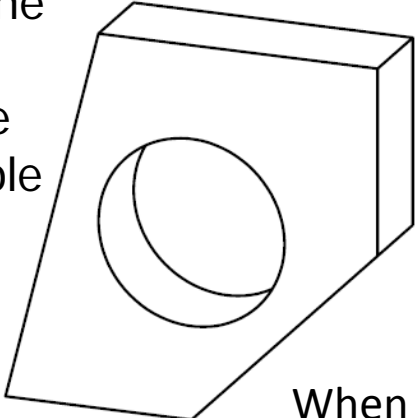

When two or more lines coincide, there is a convention called 'precedence of lines' to establish which is visible

- Visible lines
- Hidden lines and cutting plane lines
- Centre lines
- Extension & leader lines

The visible line takes precedence over the hidden edge of the hole

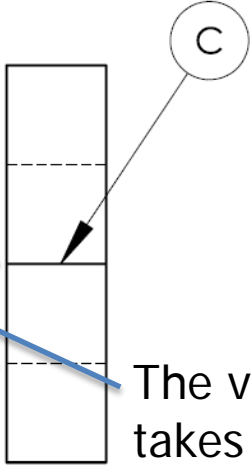
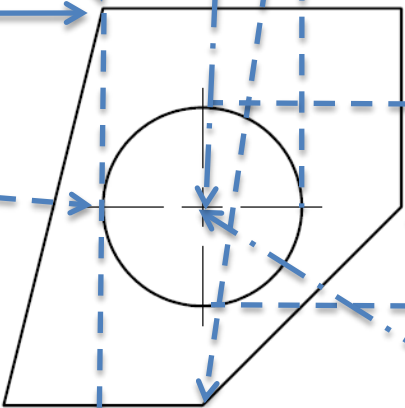

The visible line takes precedence over the centre line of the hole

An example showing the precedence of lines

Dimensions

- Two fundamental rules for dimensioning:
 - Dimensions must describe the complete geometry of the part
 - Redundant dimensions should be avoided
- More specific rules apply to the type of geometry and the placement, and style of the dimension

Dimensions

- Dimension from visible lines, not hidden features
- Repeated regular identical features may be dimensioned once along with a small note indicating quantity, etc ...
- The designer should locate dimensions in a way to indicate how tolerances accumulate

Dimensions – Example

- The repeated geometry of the holes is indicated by '2x'
- Figure (a) is incorrect.
- Figure (b) shows that the distance between the two holes is important
- Figure (c) shows that the distance from the centre of the right hole to the left edge is important

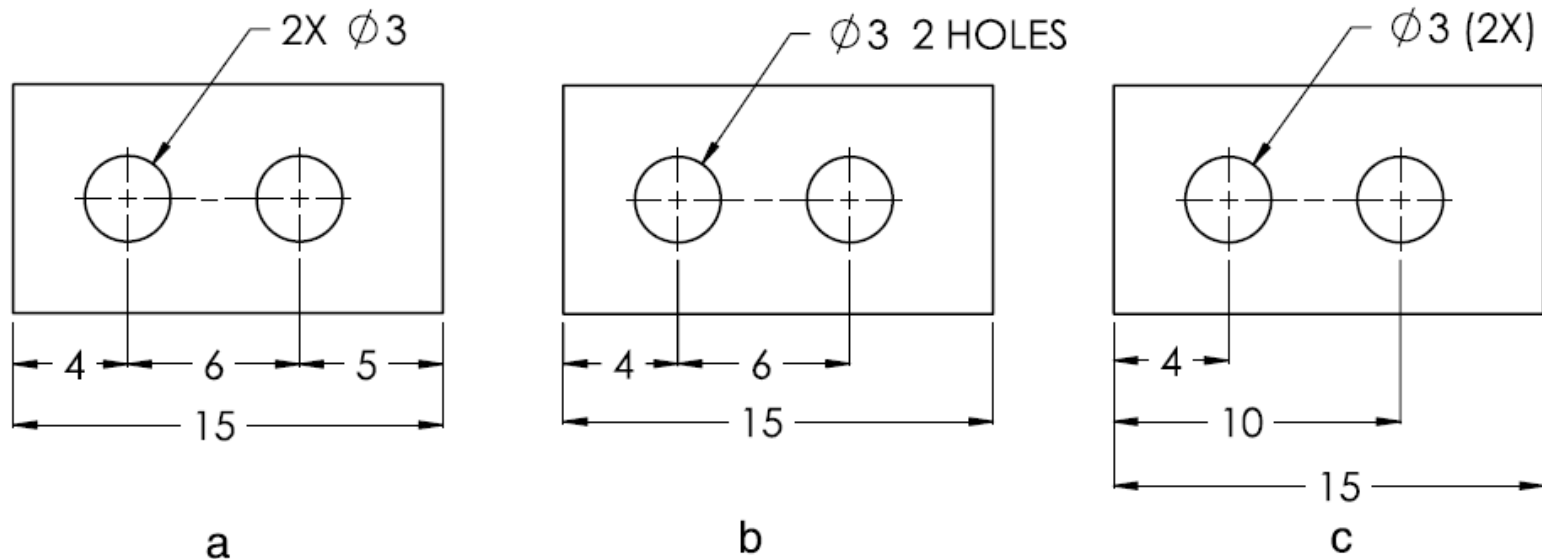

Figure 14.5 (a) An overdimensioned drawing; (b) A dimensioning scheme that emphasizes the 6-mm distance between the holes; (c) A dimensioning scheme that emphasizes the distance from the left edge to each hole.

Dimensions

- Circles and arcs (see previous example):
 - Radii are dimensioned using a leader line with an arrow at the end of the line
 - A capital “R” indicates radius
 - Dimension rounds and fillets with their radii
 - Similarly, a diameter has a leader line with an arrow
 - The symbol \varnothing indicates diameter
 - Never dimension holes or cylinders with radii ... use diameter
- Angles:
 - Fractional degree measurements can be represented with decimals or minutes and seconds
 - Dimension lines are drawn as arcs

Dimensions

- Angle dimension example:

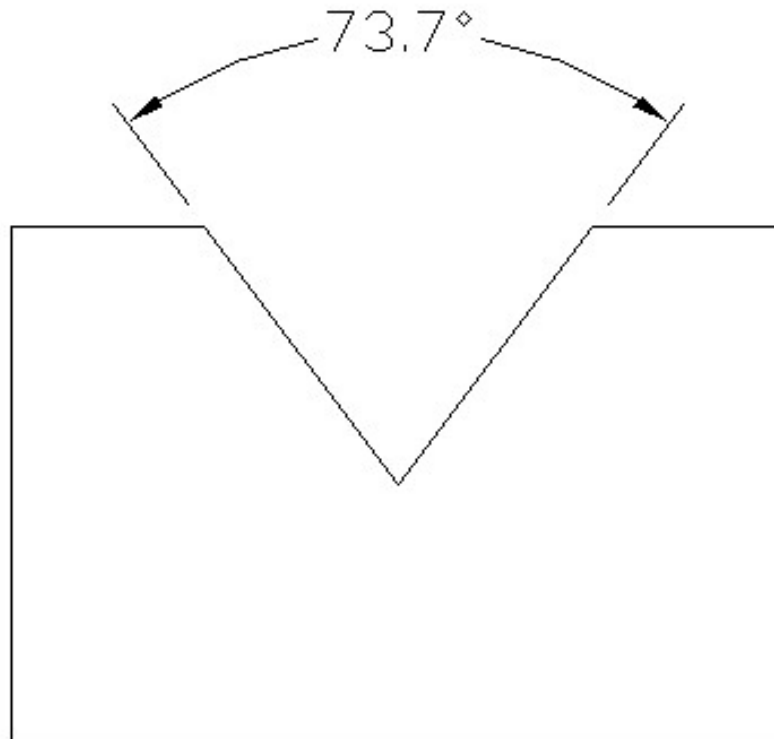

Dimensioning: Rule Zero

- When dimensioning a drawing, set the dimensioning variables so the text is readable when the drawing is printed in its final size
 - In IntelliCAD **dimscale** is the most useful command for scaling the dimension variables (text size, arrow head size, offsets, etc.)

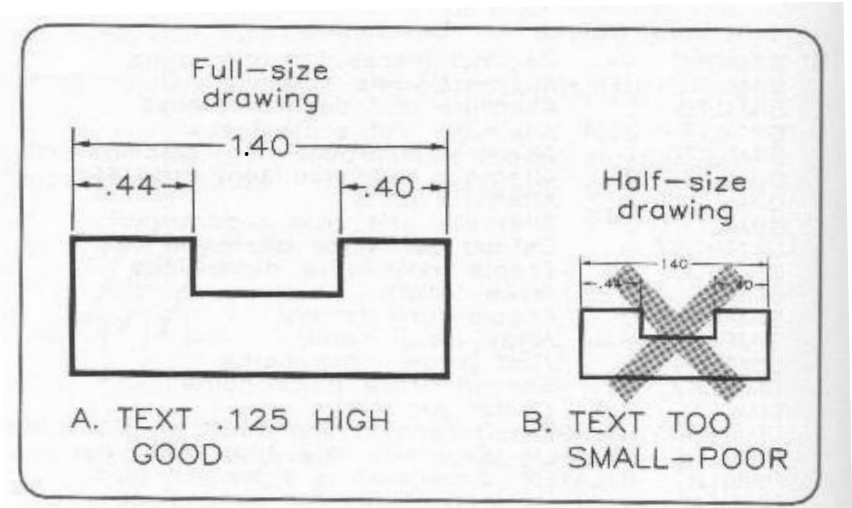

Dimensioning: Rule 1

- The first dimensions should be three times the letter height from the object
- Successive dimensions should be two times the letter height apart

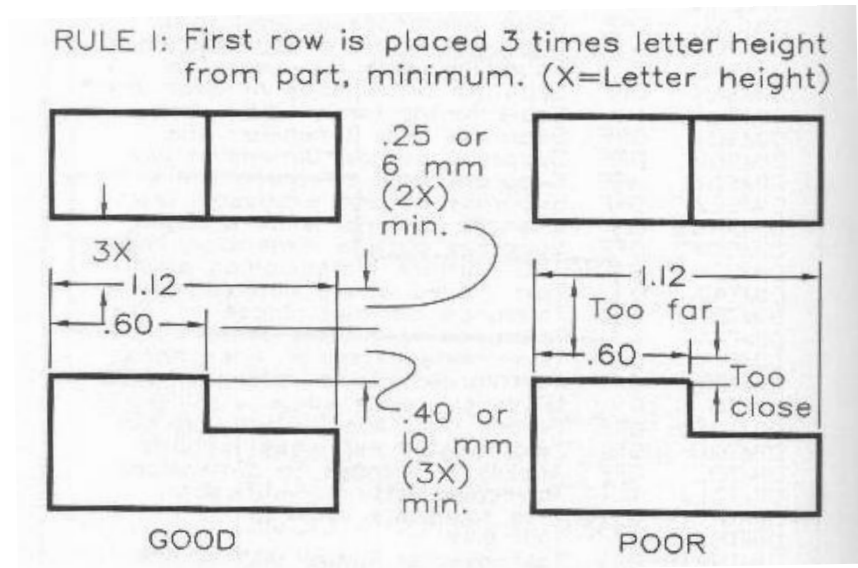

Dimensioning: Rule 2

- Place dimensions between the views sharing the same dimensions

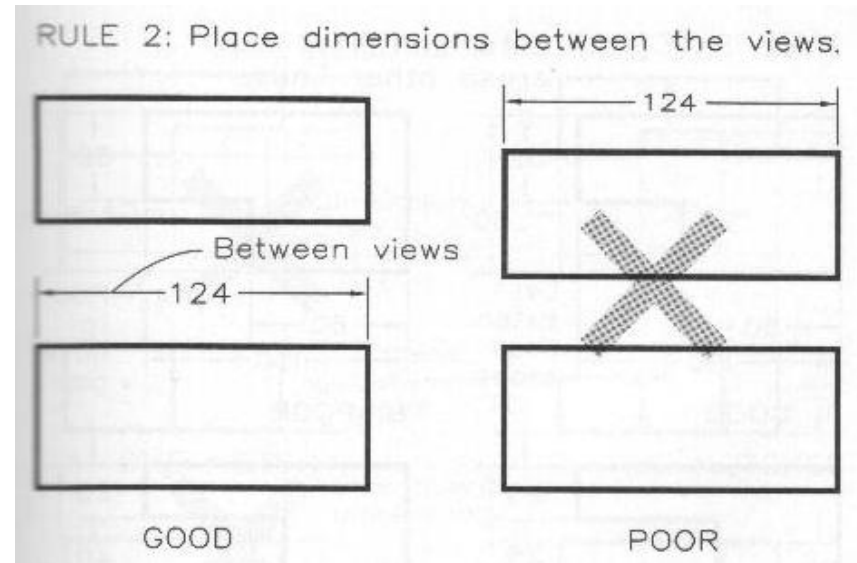

Dimensioning: Rule 3

- Dimension the most descriptive view

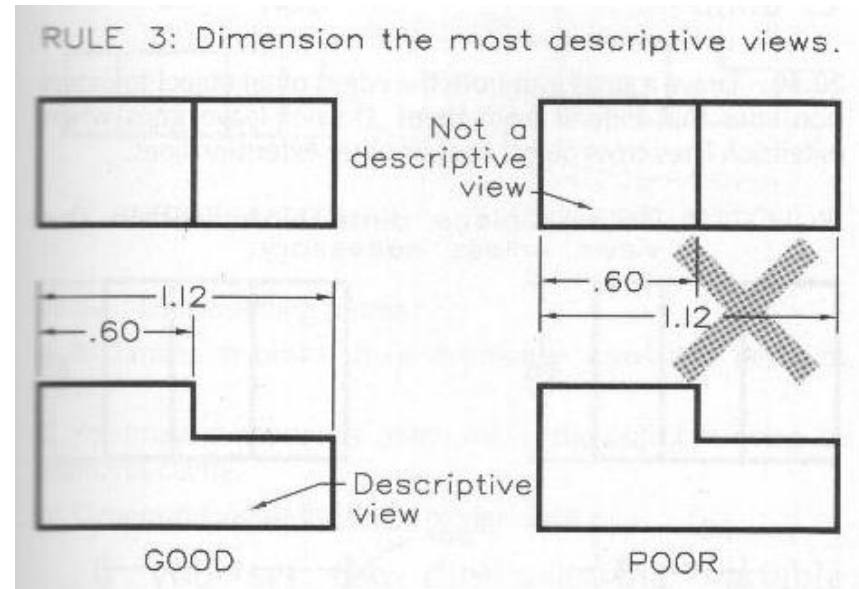

Dimensioning: Rule 4

- Dimension from visible, not hidden features

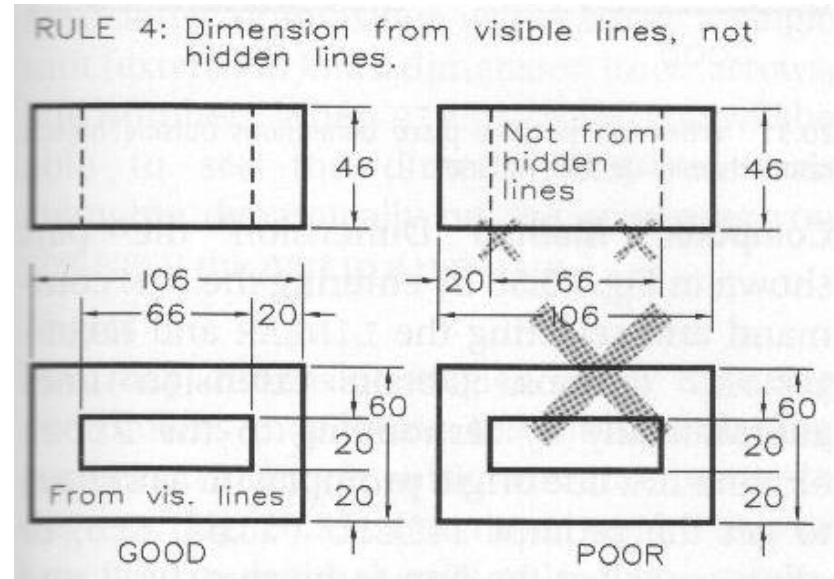

Dimensioning: Rule 5

- Give an overall dimension, omitting the last in a chain of dimensions

RULE 5: Give an overall dimension and omit one of the chain dimensions.

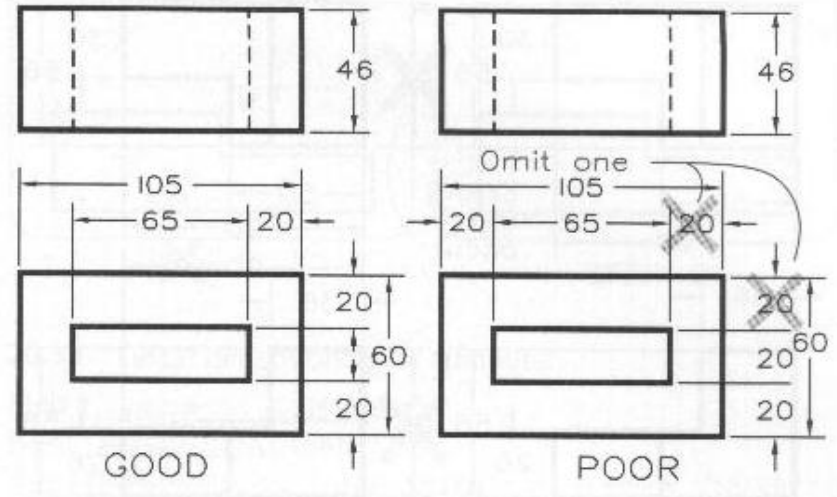

Dimensioning: Rule 6

- Organize the dimensions to reduce clutter in the drawing

RULE 6: Organize and align dimensions for ease of reading.

Dimensions aligned and grouped

Dimensions not grouped or aligned

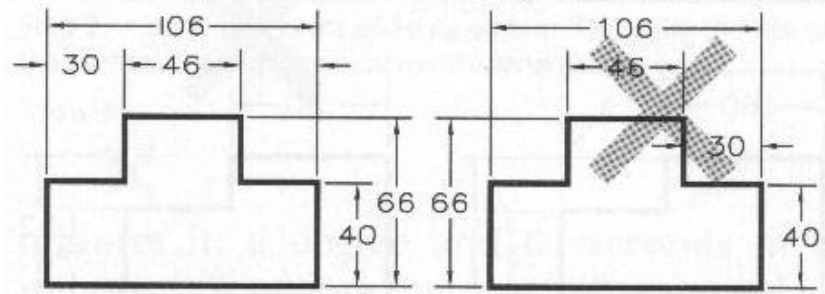

GOOD

POOR

Dimensioning: Rule 7

- To avoid errors and confusion, do not duplicate dimensions

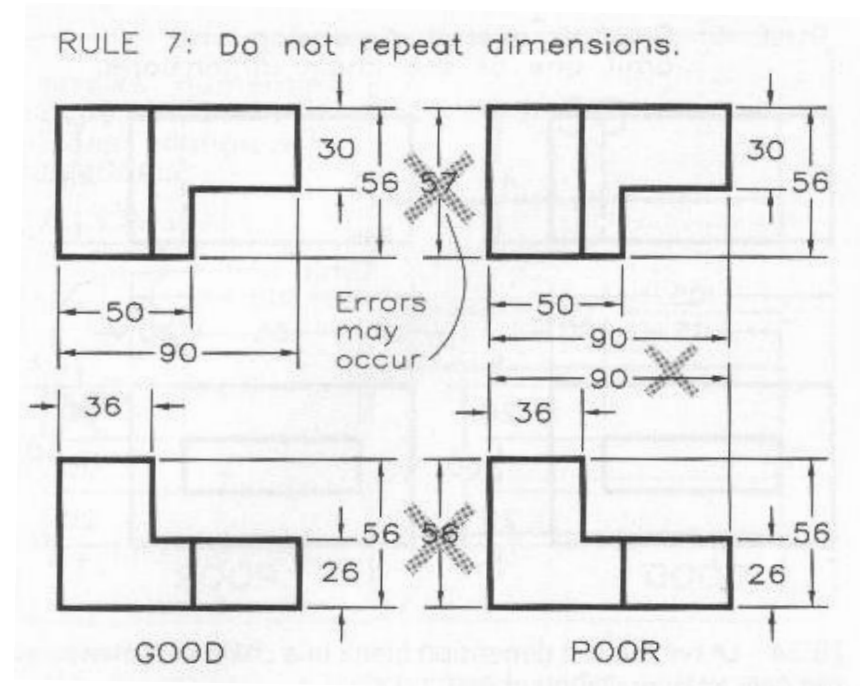

Dimensioning: Rule 8

- Dimension lines never cross any other lines, unless absolutely necessary

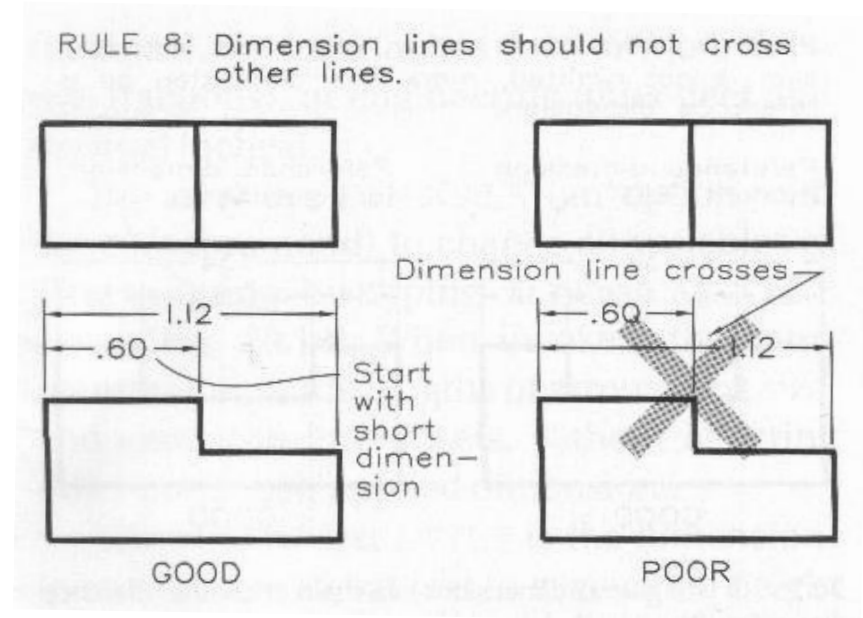

Dimensioning: Rule 9

- Extension lines may cross other extension lines, or object lines, if necessary
- Leave a small gap from the object to the lines that extend from them

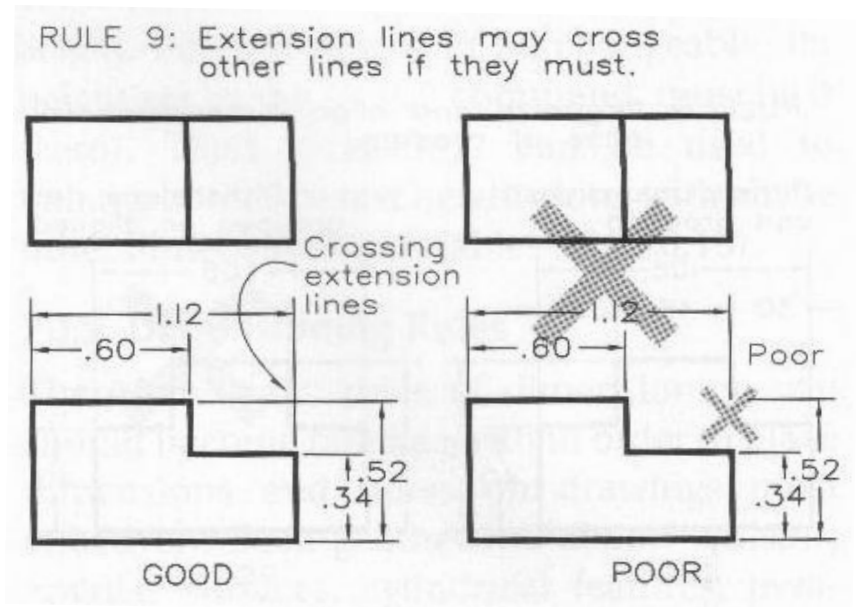

Dimensioning: Rule 9 (Cont)

- Do not leave gaps where extension lines cross object lines or other extension lines

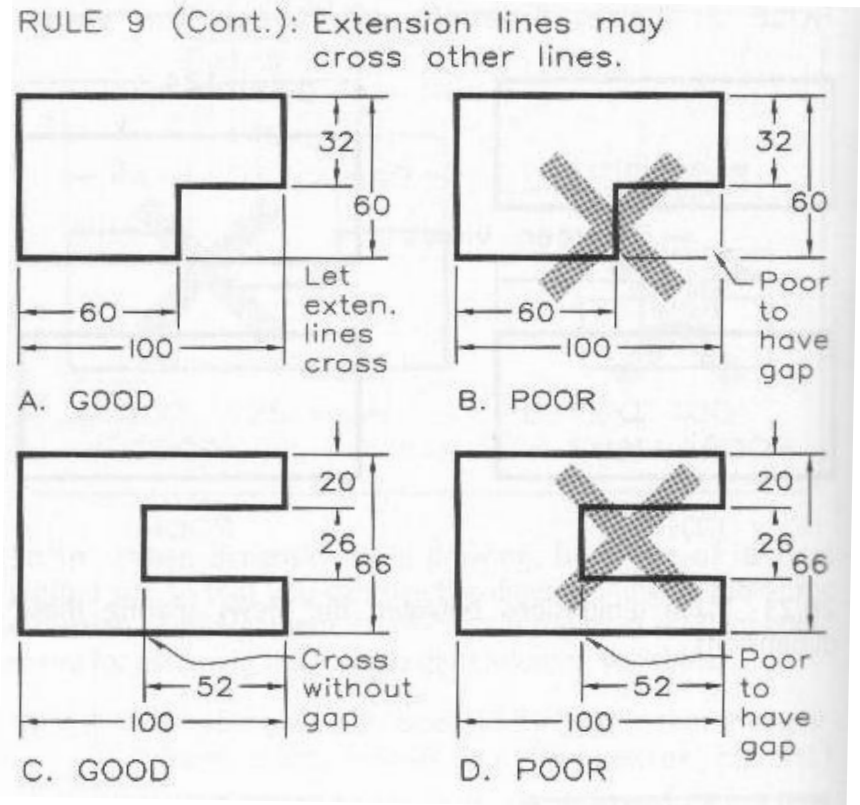

Dimensioning: Rule 10

- Where possible place dimensions outside objects

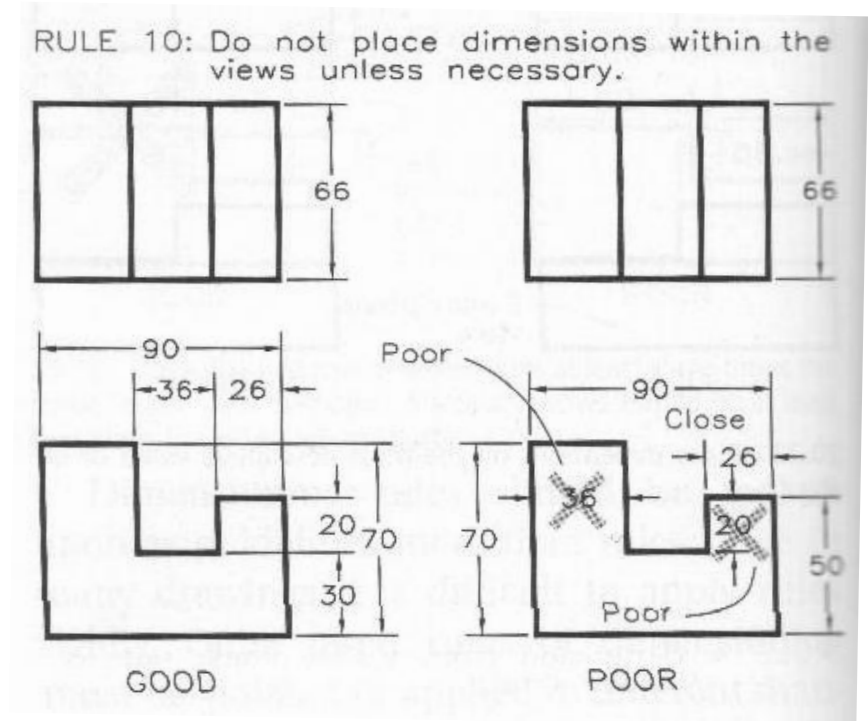

Dimensioning: Rule 11

- Dimension the diameter of cylinders in rectangular view
 - External calipers measure the diameter of a cylinder
 - Internal calipers measure the diameter of holes
- Radii cannot be measured

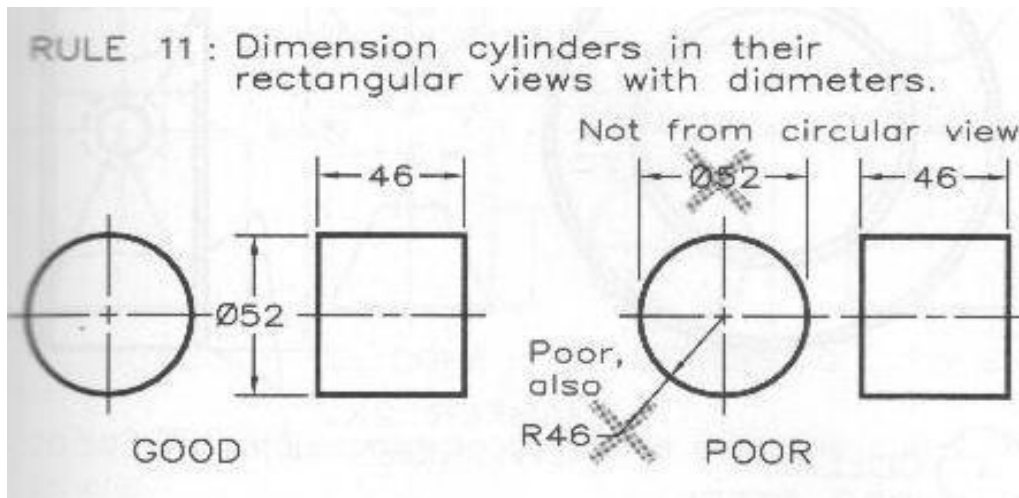
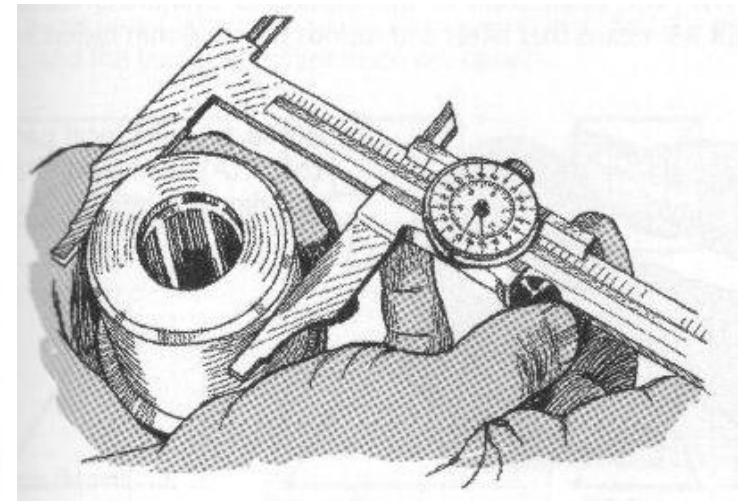
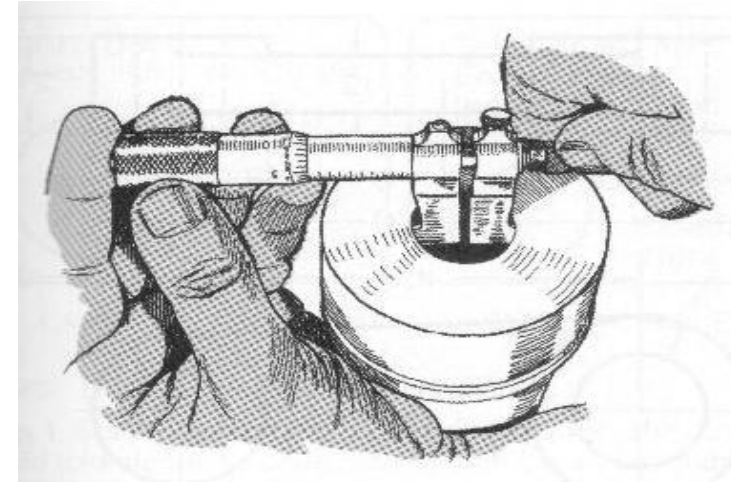

Dimensioning: Rule 12

- Dimension circular holes in the view where they look like holes

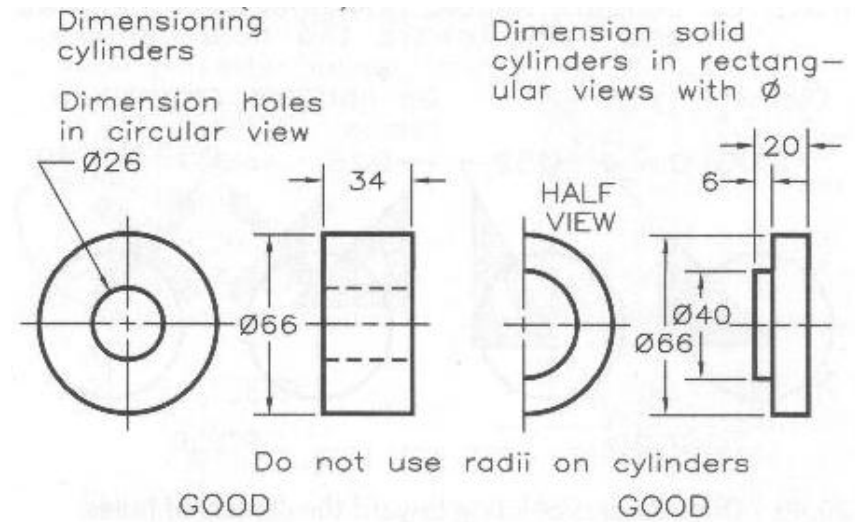

Dimensioning: Rule 12 (Cont)

- Dimension circular holes in the view where they look like holes

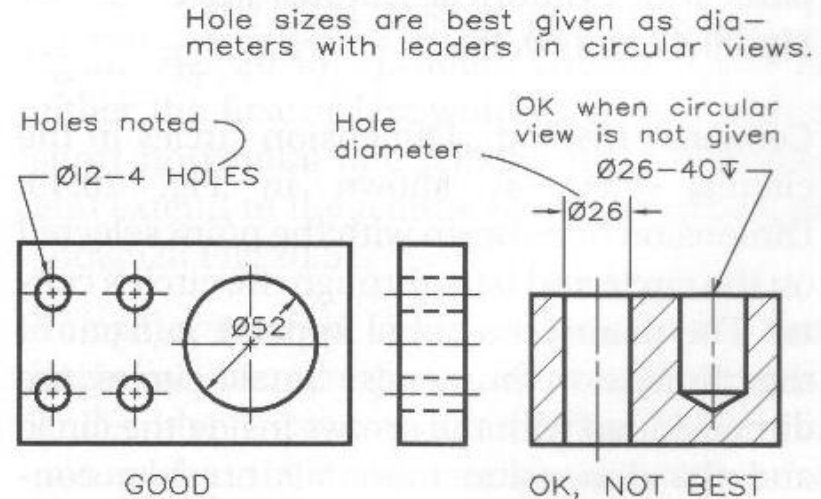

Dimensioning - Example

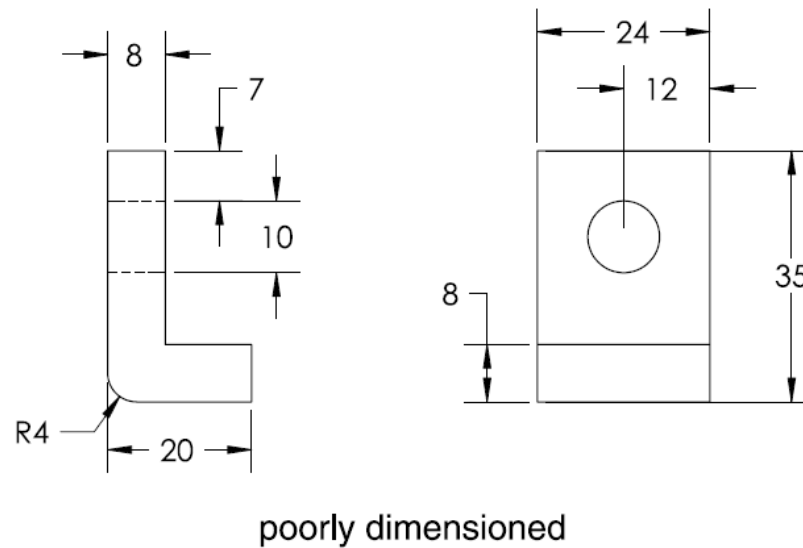
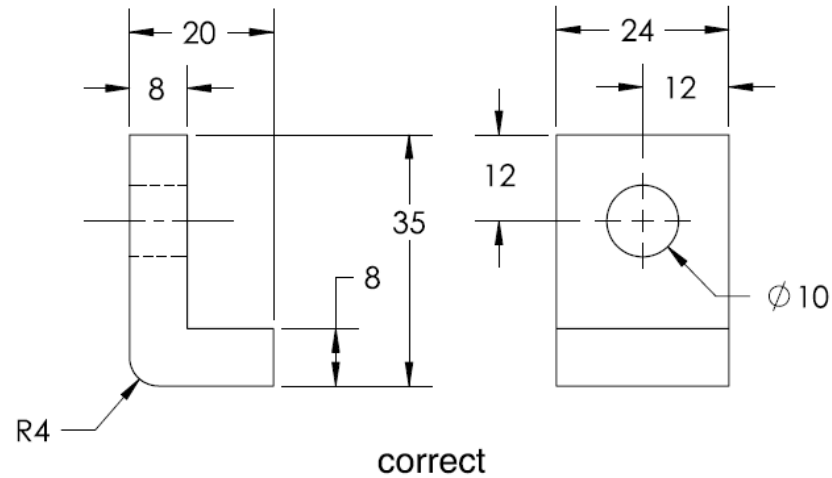

Figure 14.7 Properly and improperly dimensioned drawings.

Orthographic Projection

- Advantages
 - Able to contain a high degree of detail
 - Angle and length measurements can be made on all views (exceptions do exist)
- Disadvantages
 - Effort is needed to interpret the object
 - Many conventions must be followed – not as easy as the other three

Drawing Layout Conventions

- Layout possibilities other than three-view exist for orthographic drawings
- Sometimes, only two views are necessary
- The same rules still apply to these projections
 - For example, the views must be aligned
- The designer must choose the best layout to convey the information in the most effective way possible

Orthographic – Section Views

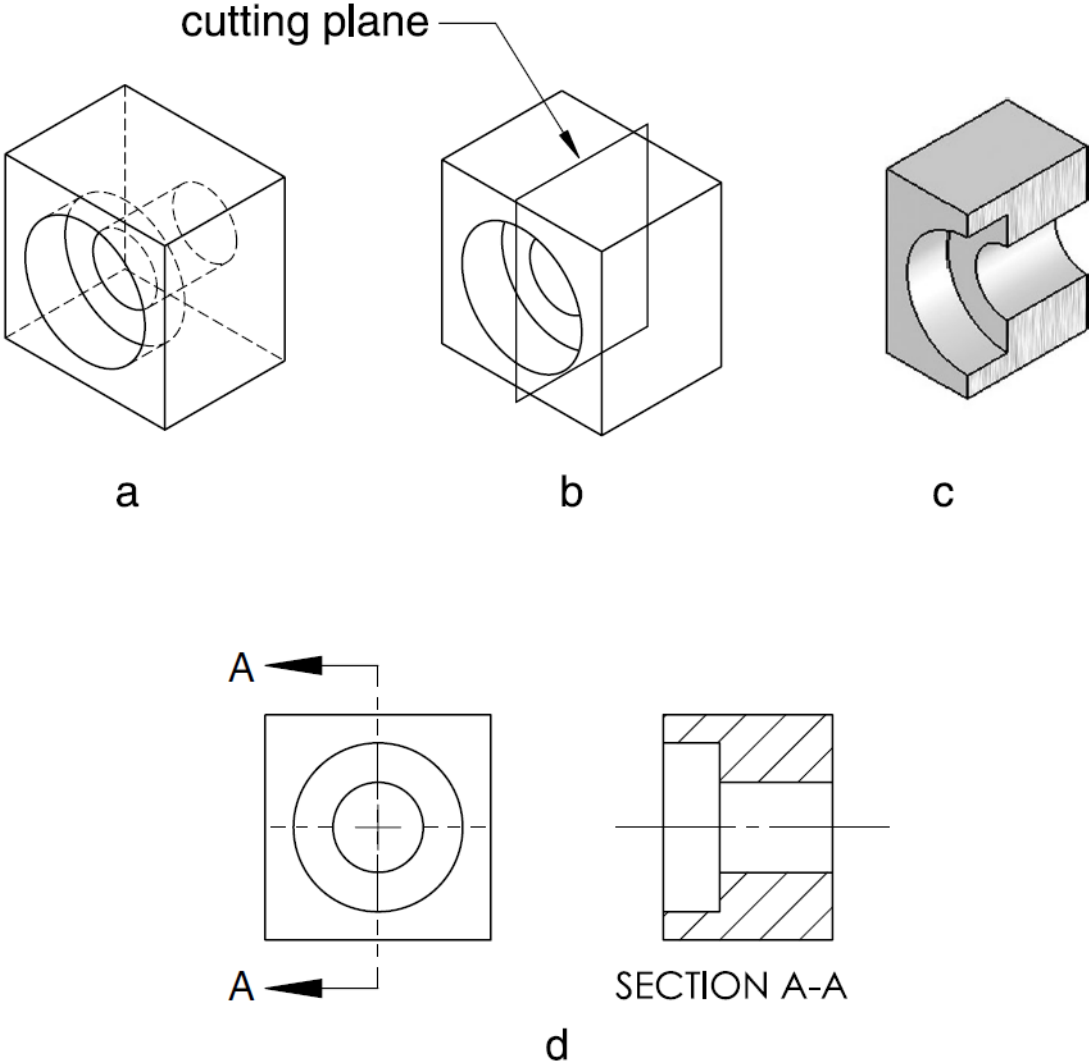
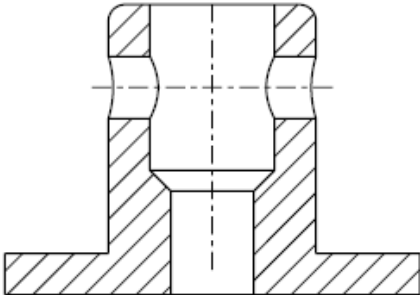
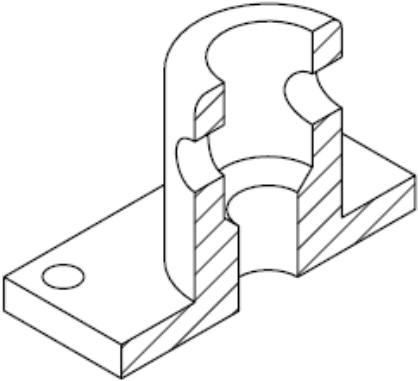
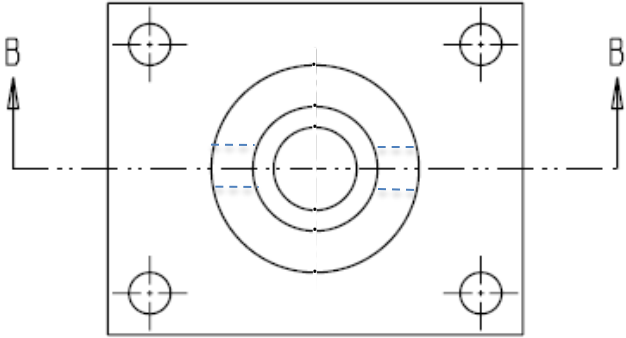
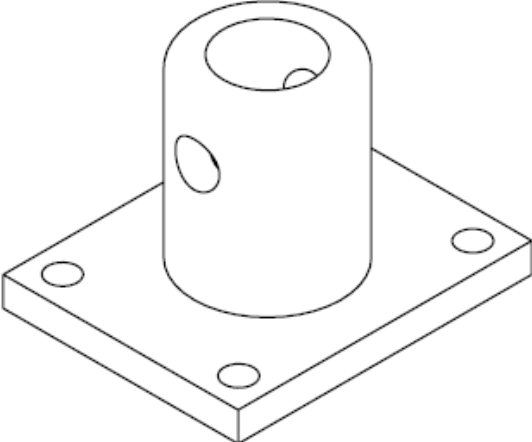

Figure 14.10 Creating a section view.

Orthographic – Section Views



SECTION B-B

Corrected Figure 14.11 The full section is the orthographic view at the lower right.

Orthographic – Section Views

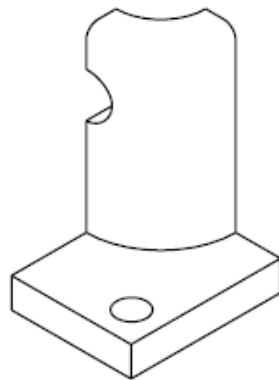
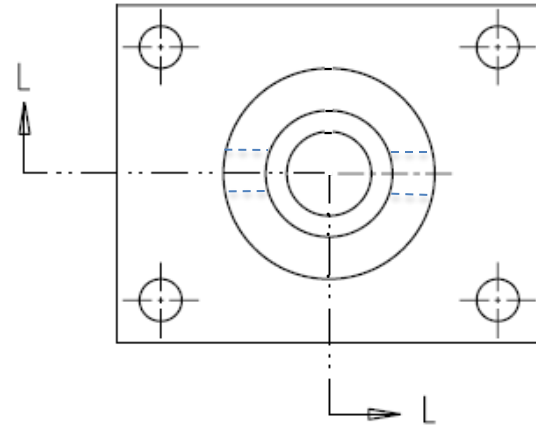
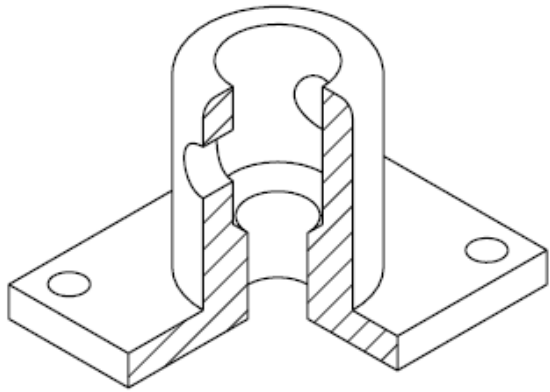

Removed Portion

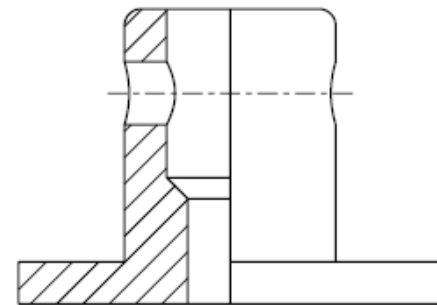

SECTION L-L

Corrected **Figure 14.12** The half section is the orthographic view at the lower right.

Orthographic – Section Views

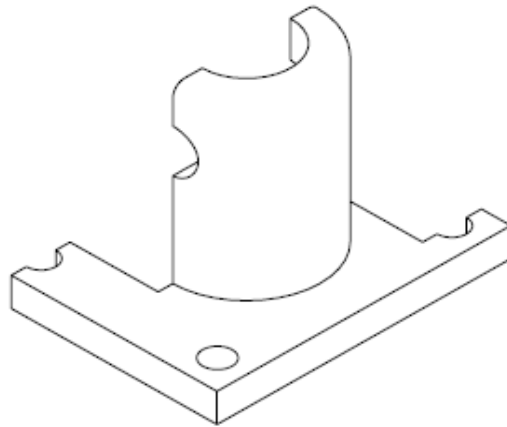
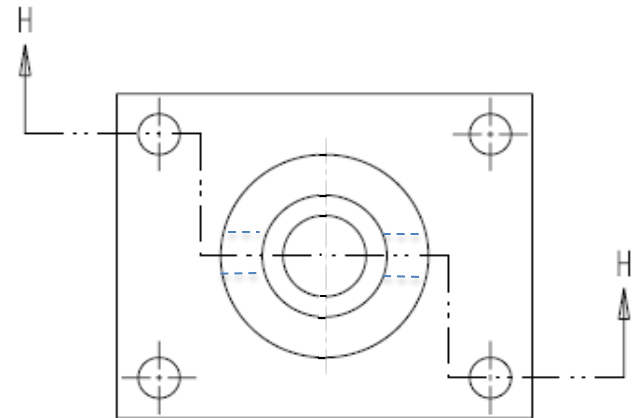
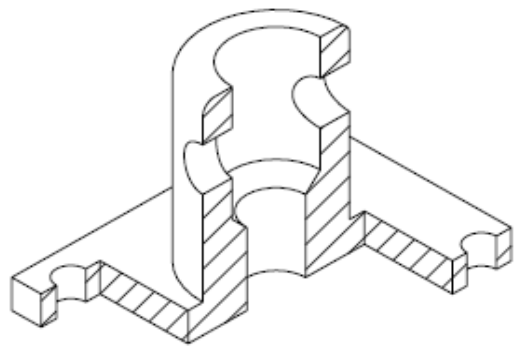

Removed Portion

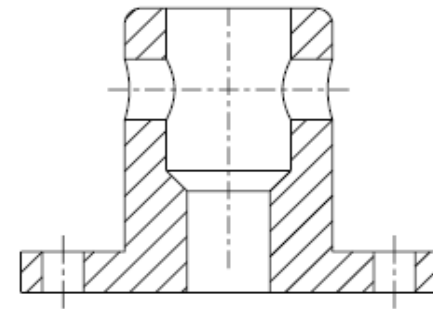

SECTION H-H

Corrected Figure 14.14 The offset section is the orthographic view at the lower right. Note that the horizontal holes in the cylindrical upper portion of the part have curved edges in the section view due to the shape of the part, whereas the vertical holes in the flat flange at the bottom of the part have straight edges.

Orthographic – Section Views

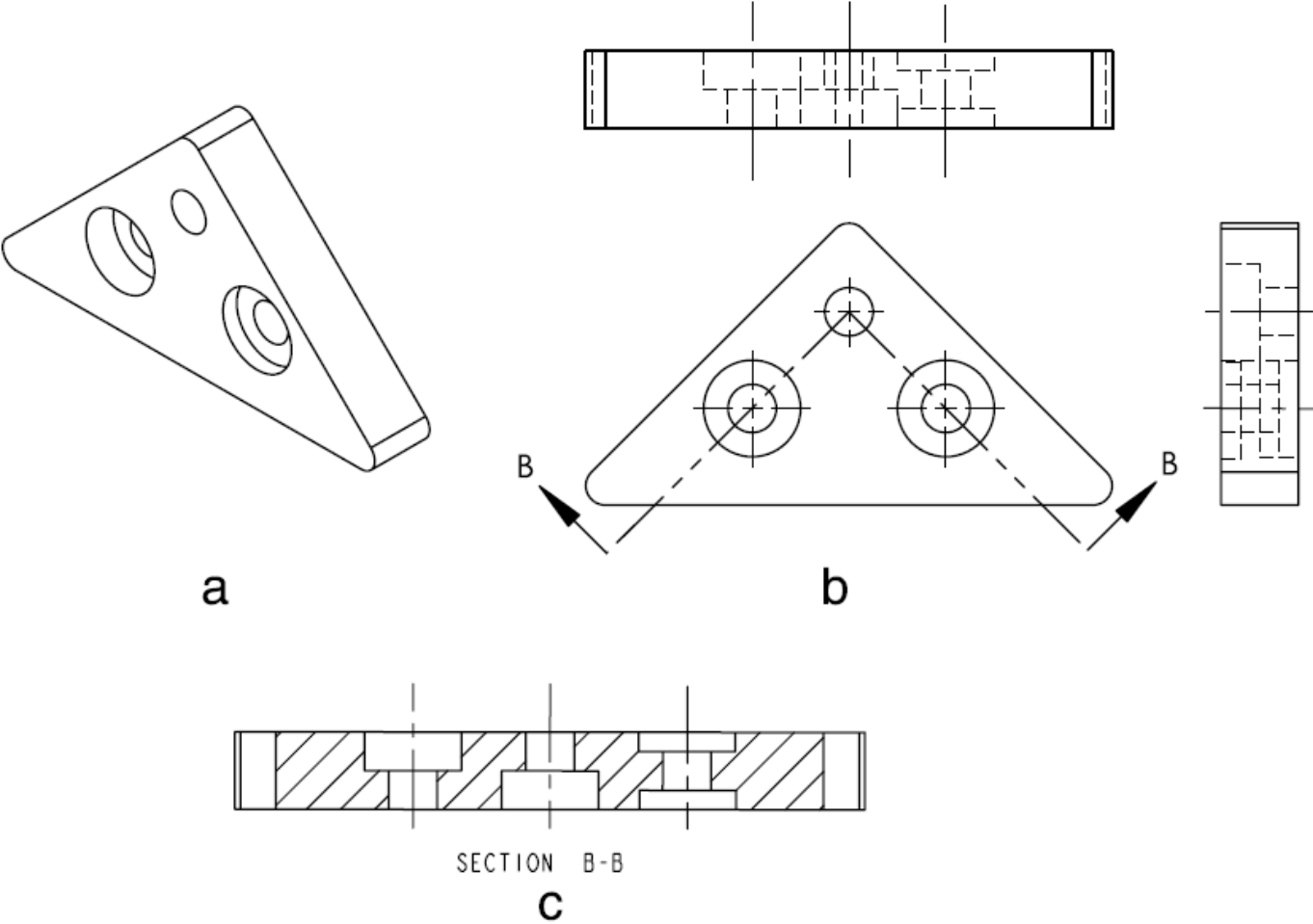
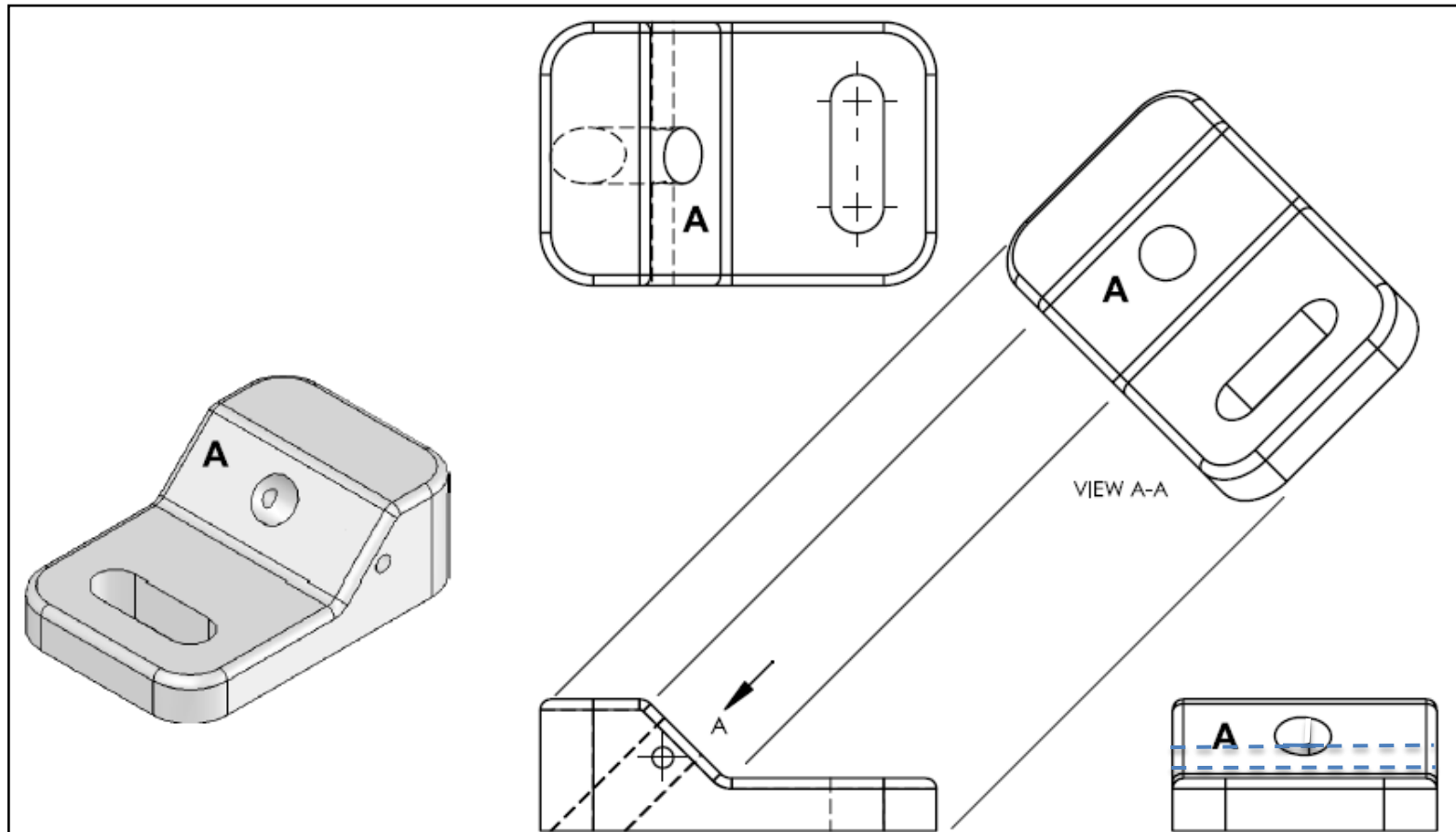

Figure 14.15 The aligned section is shown in (c).

Orthographic – Auxiliary Views



Corrected

Figure 14.18 Auxiliary view of plane A. The labels A on the isometric projection and on the auxiliary and right views are not included on standard drawings.

Drawing Layout Conventions

- Sometimes, the rules of projection must be violated in order to improve clarity
- **EXAMPLE:** Symmetrically spaced holes on a circular plate:
 - In the front view, the holes are represented by hidden lines placed at the maximum radial distance from the centre of the plate
 - In the top view, the holes are placed where they physically exist

Drawing Layout Conventions

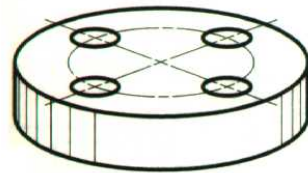

No center hole

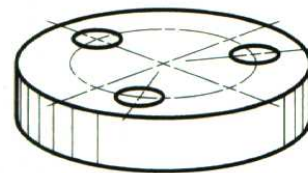

Rotate holes in top

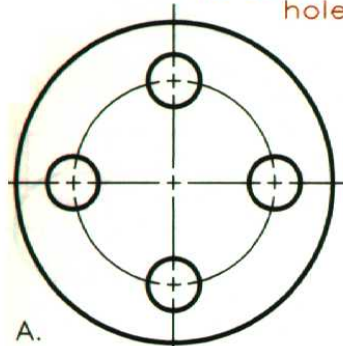

A.

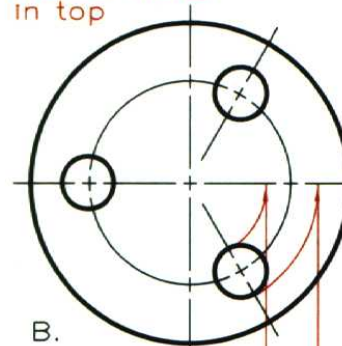

B.

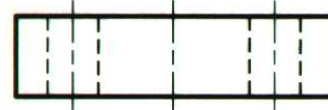

GOOD No center hole

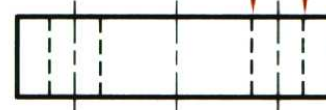

GOOD Symmetrical



POOR Appears to have hole in center



POOR Holes not symmetrical

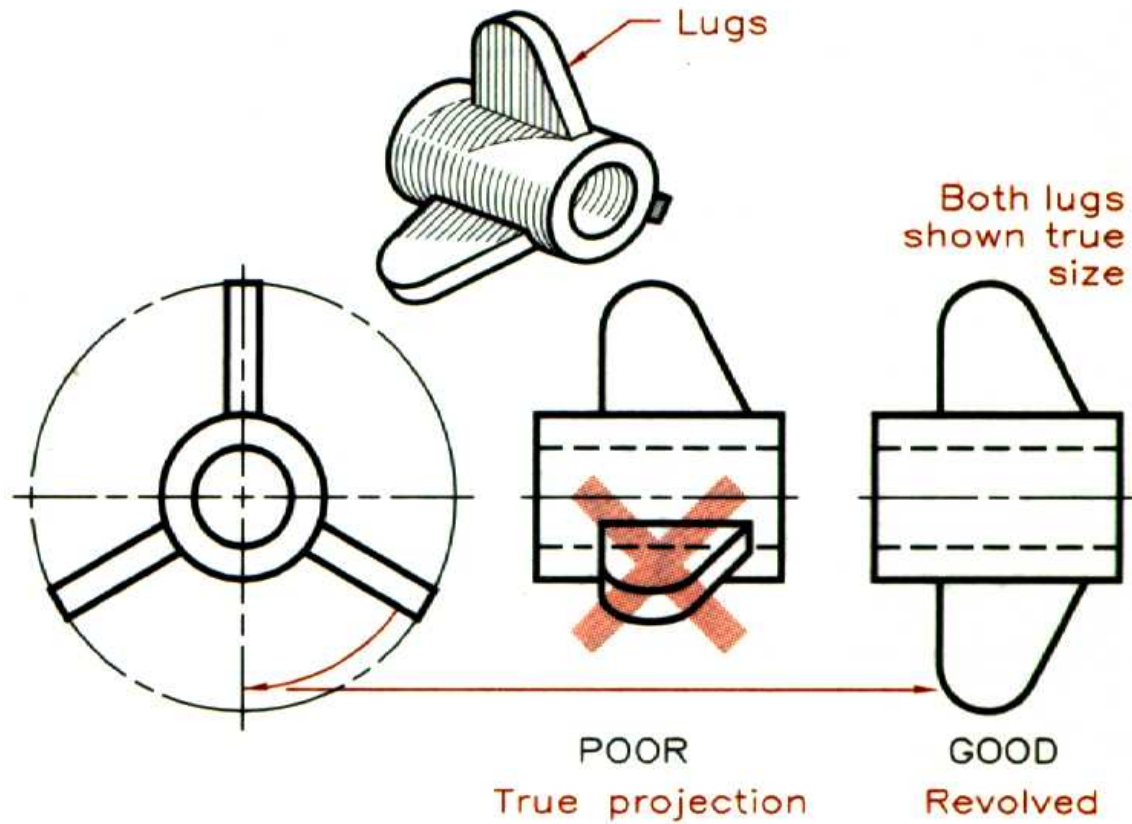

Drawing Layout Conventions

Applies to other symmetric features such as webs, ribs, and lugs

Orthographic – Threads

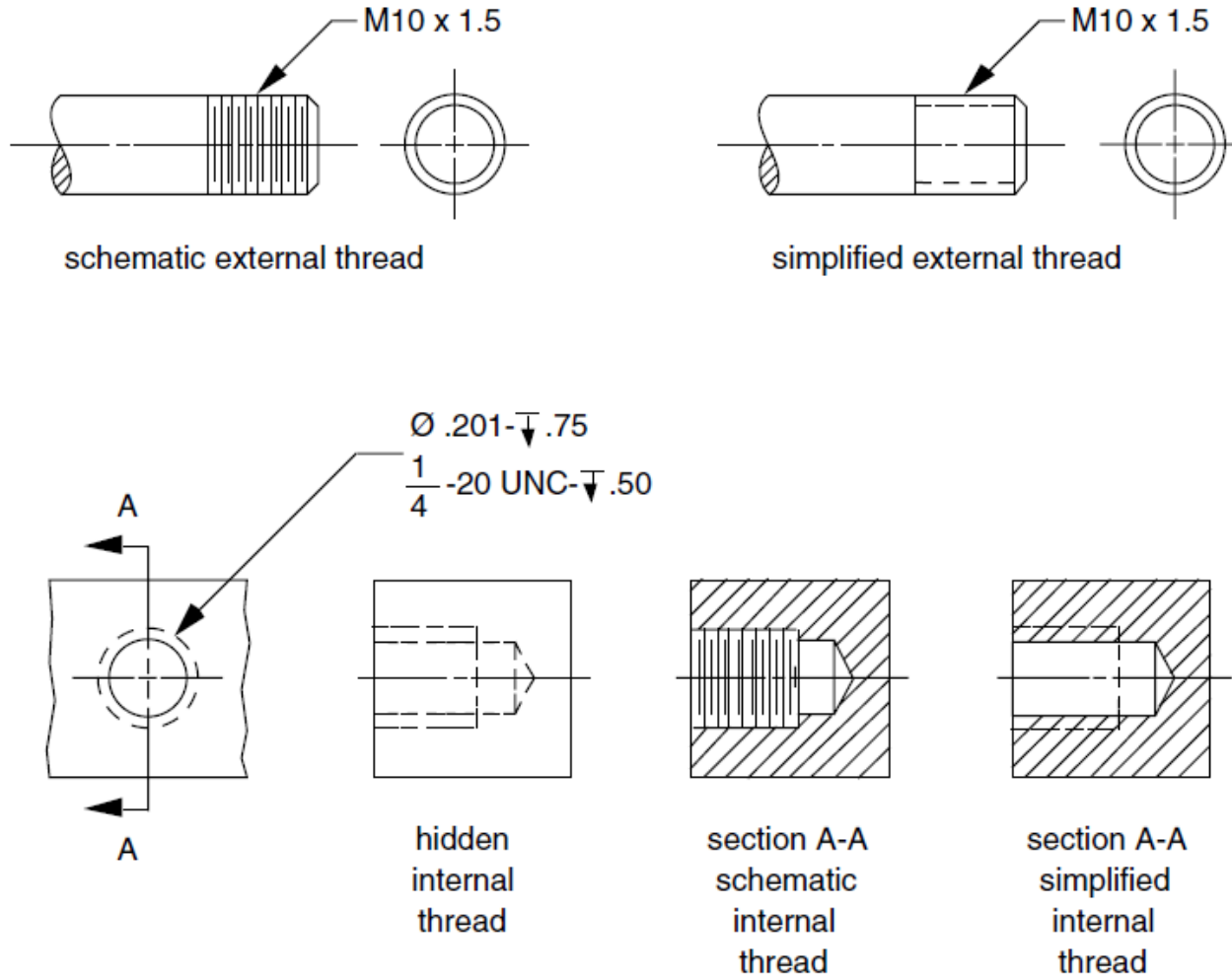
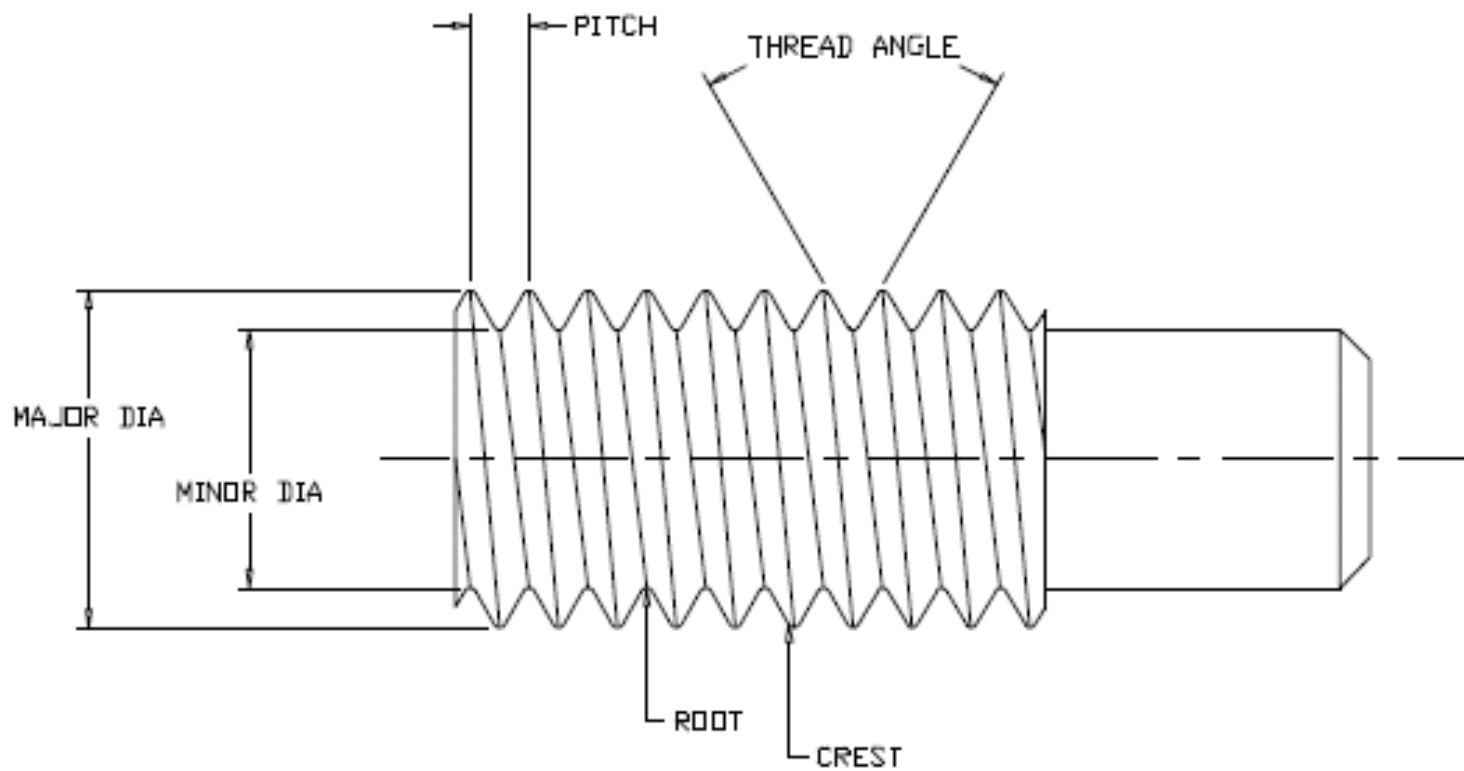
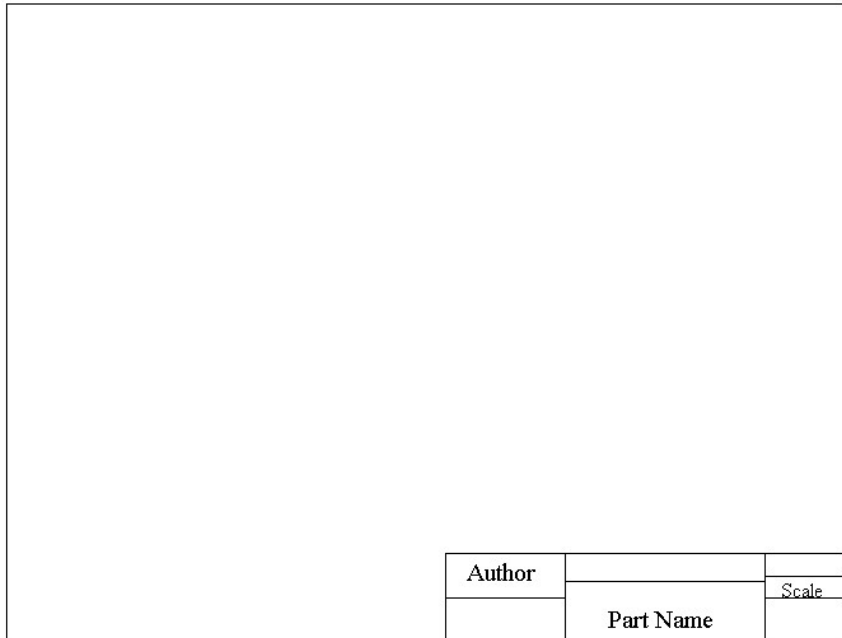

Figure 14.21 Conventions to show screw threads.



Orthographic – Title Block

- Contains important information about the drawing such as the **part name and number**, the **person who made it** and the **scale used**
 - Usually located in the lower right corner of the drawing
 - All working drawings have a title block!



Author		Scale
	Part Name	

Orthographic – Title Block

UNLESS OTHERWISE SPECIFIED DIMENSIONS ARE IN INCHES TOLERANCES ARE: FRACTIONS DECIMALS ANGLES $\pm 1/32$ $.XX \pm .01$ $\pm 1^\circ$ $.XXX \pm .005$	CAD GENERATED DRAWING, DO NOT MANUALLY UPDATE		PIZZA CUTTERS INCORPORATED	
	APPROVALS		DATE	
	DRAWN	MJM	10.10.99	
	CHECKED	RML	10.12.99	
	RESP ENG	LDV	10.13.99	
MATERIAL	--	MFG ENG	AA	10.15.99
FINISH	--	QUAL ENG	DM	10.15.99
DO NOT SCALE DRAWING			SIZE A	DWG. NO. 554391
			SCALE 1:2	CAD FILE: pizza cutter.sldasm
			SHEET 1	OF 1
A				

Figure 14.2 A typical title block.

Special Drawing Conventions

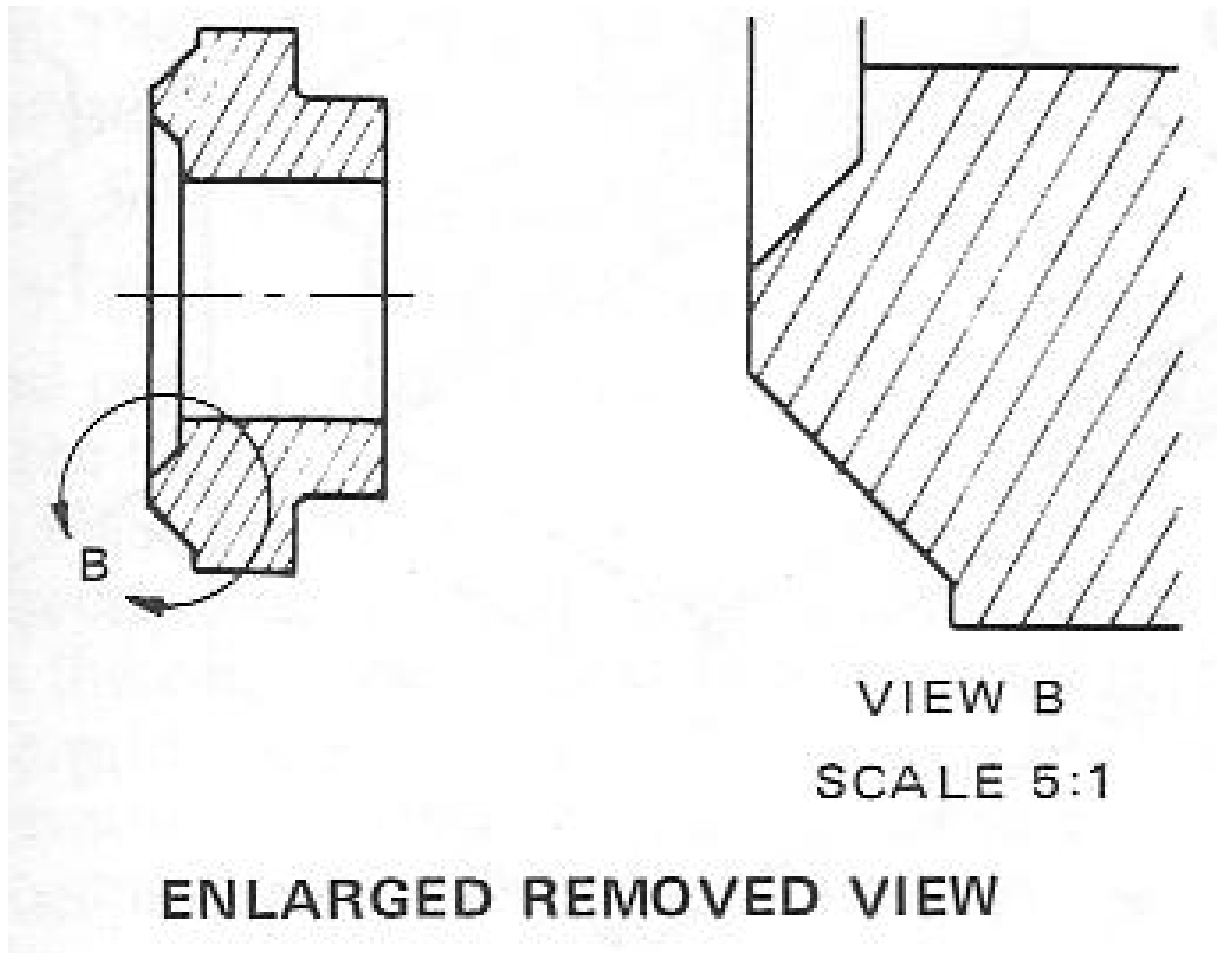

Special Drawing Conventions

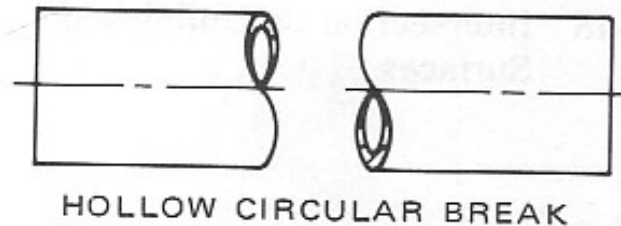
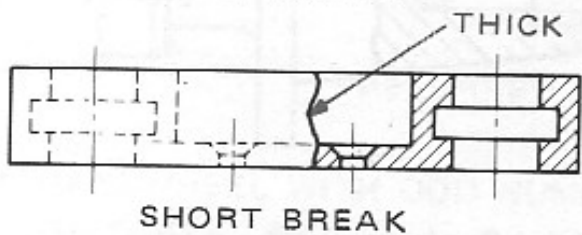
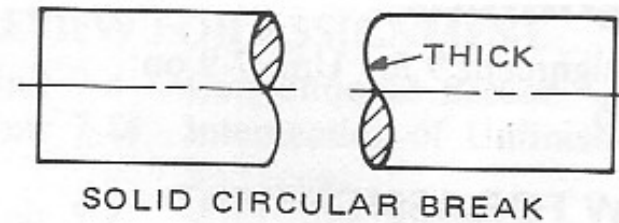
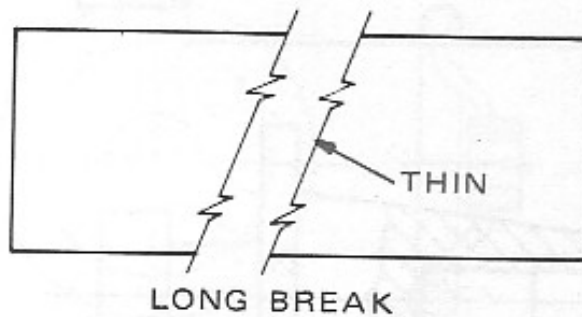
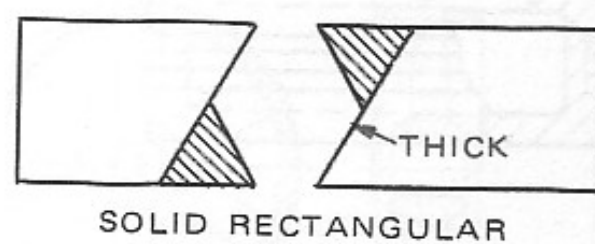
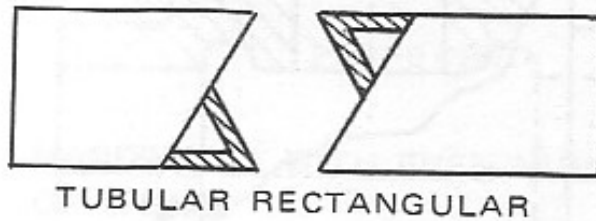

Conventional breaks.

Orthographic – Example - 2

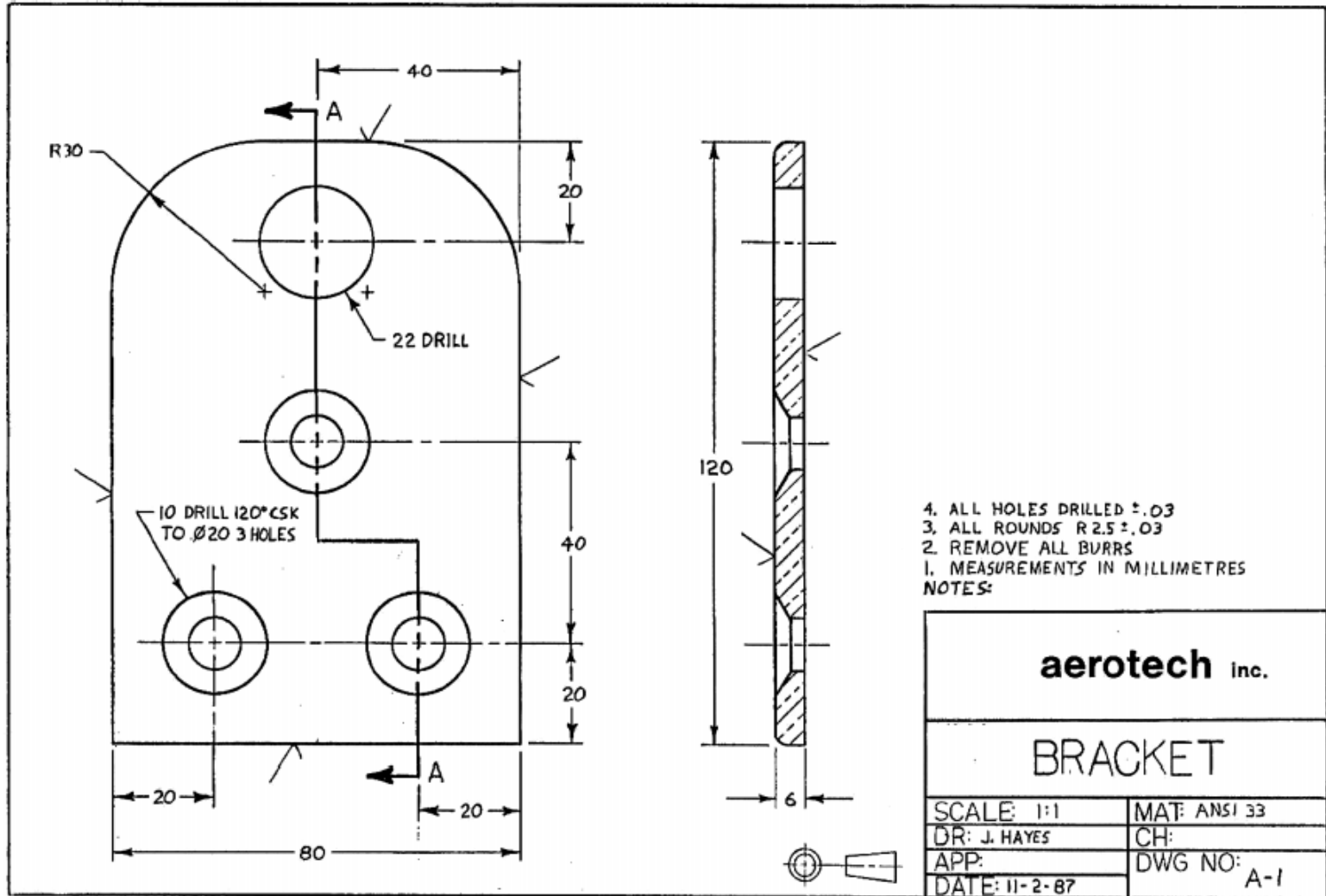

Figure 12.21 Working drawing for a bearing bracket.

Orthographic – Example - 3

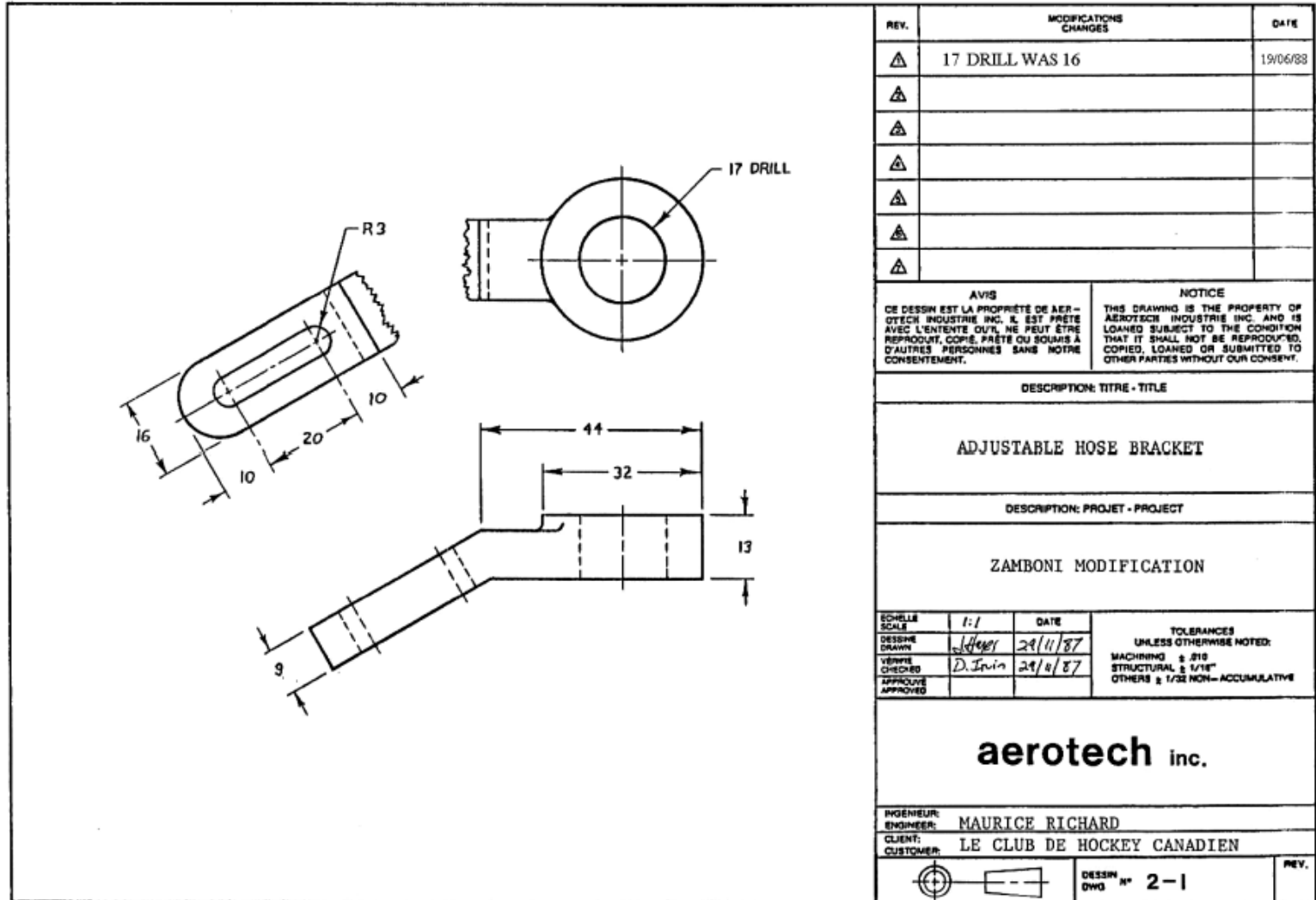
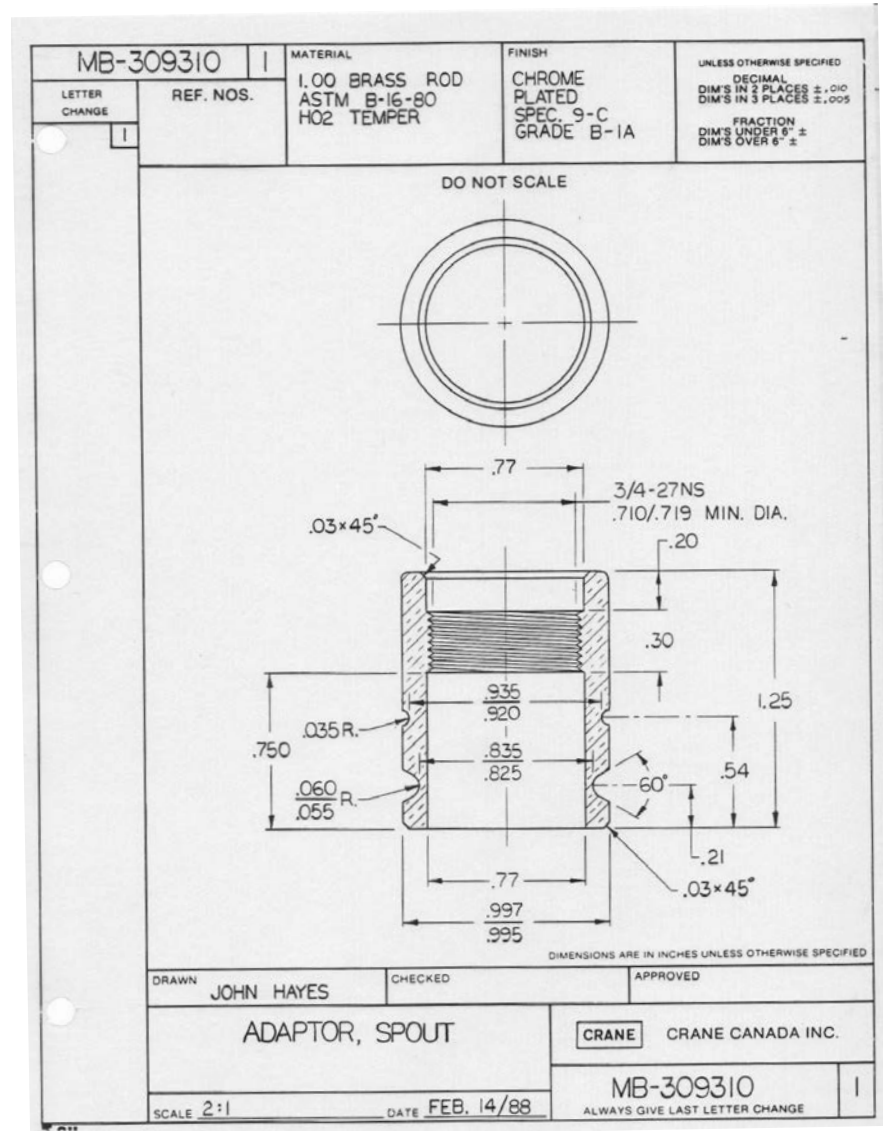
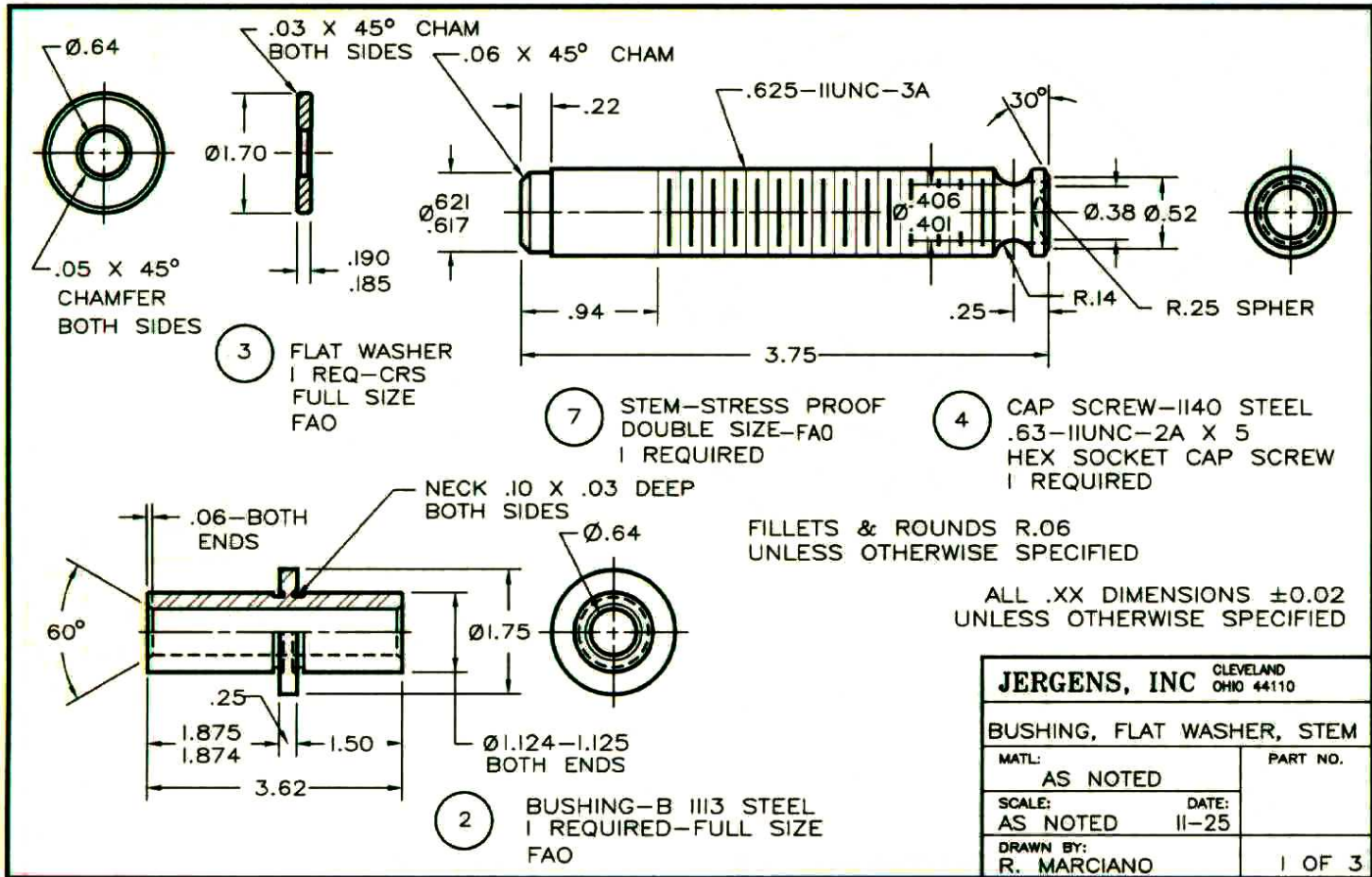

Figure 12.22 Working drawing with an auxiliary view and a revision block.

Orthographic – Example - 4



Orthographic – Example - 5



Reading Assignment

- Have you read Chapters 12 & 14 ?
- Read Chapter 13