

## Tutorial 1

Questions 1-5 are from the textbook Callister, 8<sup>th</sup> ed. Chapter 3 (3.3, 3.30, 3.31, 3.39, 3.40)

1. Show for the body-centered cubic crystal structure that the unit cell edge length “ $a$ ” and the atomic radius “ $R$ ” are related through  $a = \frac{4R}{\sqrt{3}}$

2. Within a cubic unit cell, sketch the following directions:

$$[\bar{1}10], [\bar{1}\bar{2}1], [0\bar{1}2], [1\bar{3}3], [\bar{1}\bar{1}1], [\bar{1}22], [1\bar{2}\bar{3}], [\bar{1}03]$$

3. Determine the indices for the directions shown in the following cubic unit cell:

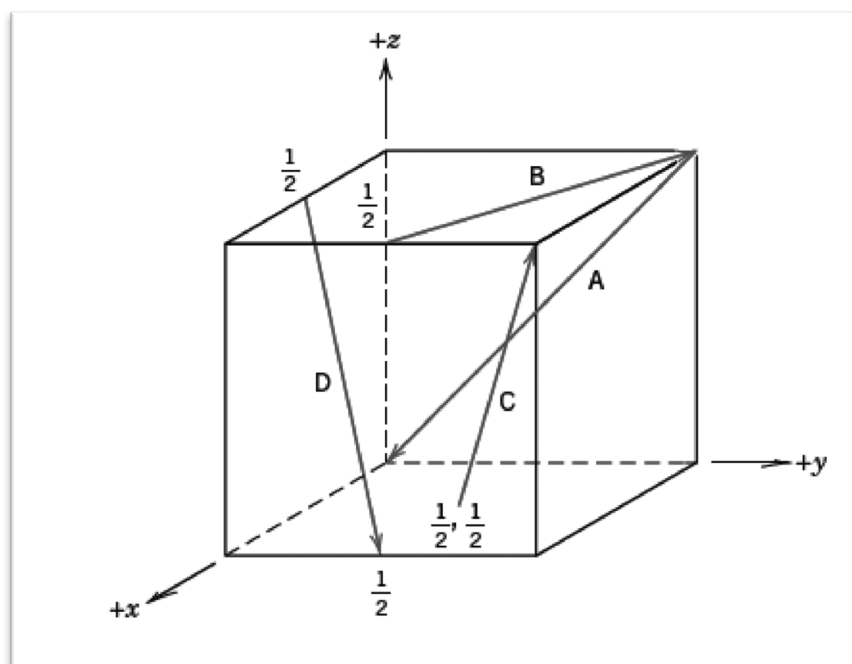

4. What are the indices for the two planes drawn in the sketch below?

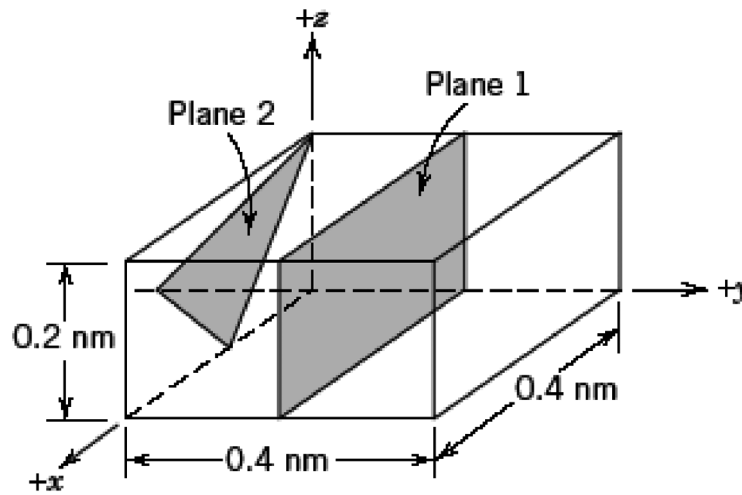

5. Sketch within a cubic unit cell the following planes:

$$(0\bar{1}\bar{1}), (11\bar{2}), (10\bar{2}), (1\bar{3}1), (\bar{1}1\bar{1}), (1\bar{2}\bar{2}), (\bar{1}\bar{2}\bar{3}), (0\bar{1}\bar{3})$$

6. Determine the indices for the directions in the hexagonal lattice shown in the Figure, using both the three-digit and four-digit systems.

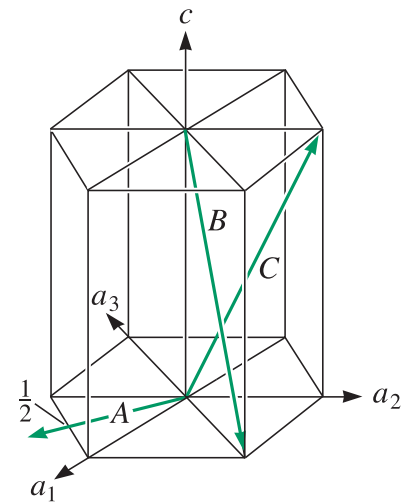

7. Determine the indices for the planes in the hexagonal lattice shown in the Figure.

