

**ITI1100A**  
**Assignment # 2**  
**SOLUTIONS**

**2.1**

(a)

x y z	x+y+z	(x+y+z)'	x'	y'	z'	x'y'z'
000	0	1	1	1	1	1
001	1	0	1	1	0	0
010	1	0	1	0	1	0
011	1	0	1	0	0	0
100	1	0	0	1	1	0
101	1	0	0	1	0	0
110	1	0	0	0	1	0
111	1	0	0	0	0	0

x y z	(xyz)	(xyz)'	x'	y'	z'	x'+y'+z'
000	0	1	1	1	1	1
001	0	1	1	1	0	1
010	0	1	1	0	1	1
011	0	1	1	0	0	1
100	0	1	0	1	1	1
101	0	1	0	1	0	1
110	0	1	0	0	1	1
111	1	0	0	0	0	0

(b)

x y z	x+yz	x+y	x+z	(x+y)(x+z)
000	0	0	0	0
001	0	0	1	0
010	0	1	0	0
011	1	1	1	1
100	1	1	1	1
101	1	1	1	1
110	1	1	1	1
111	1	1	1	1

(c)

x y z	x(y+z)	xy	xz	xy+xz
000	0	0	0	0
001	0	0	0	0
010	0	0	0	0
011	0	0	0	0
100	0	0	0	0
101	1	0	1	1
110	1	1	0	1
111	1	1	1	1

(d)

x y z	x	y+z	x+(y+z)	(x+y)	(x+y)+z
000	0	0	0	0	0
001	0	1	1	0	1
010	0	1	1	1	1
011	0	1	1	1	1
100	1	0	1	1	1
101	1	1	1	1	1
110	1	1	1	1	1
111	1	1	1	1	1

(e)

x y z	yz	x(yz)	xy	(xy)z
000	0	0	0	0
001	0	0	0	0
010	0	0	0	0
011	1	0	0	0
100	0	0	0	0
101	0	0	0	0
110	0	0	1	0
111	1	1	1	1

**2.4**

(a)  $A'C' + ABC + AC' = C' + ABC = (C + C')(C' + AB) = AB + C'$

(b)  $(x'y' + z)' + z + xy + wz = (x'y)'z' + z + xy + wz = [(x + y)z' + z] + xy + wz$

$= (z + z')(z + x + y) + xy + wz = z + wz + x + xy + y = z(1 + w) + x(1 + y) + y = x + y + z$

- (c)  $A'B(D' + C'D) + B(A + A'CD) = B(A'D' + A'C'D + A + A'CD)$   
 $= B(A'D' + A + A'D(C + C')) = B(A + A'(D' + D)) = B(A + A') = B$
- (d)  $(A' + C)(A' + C')(A + B + C'D) = (A' + CC')(A + B + C'D) = A'(A + B + C'D)$   
 $= AA' + A'B + A'C'D = A'(B + C'D)$
- (e)  $ABC'D + A'BD + ABCD = AB(C + C')D + A'BD = ABD + A'BD = BD$

## 2.7

(a)

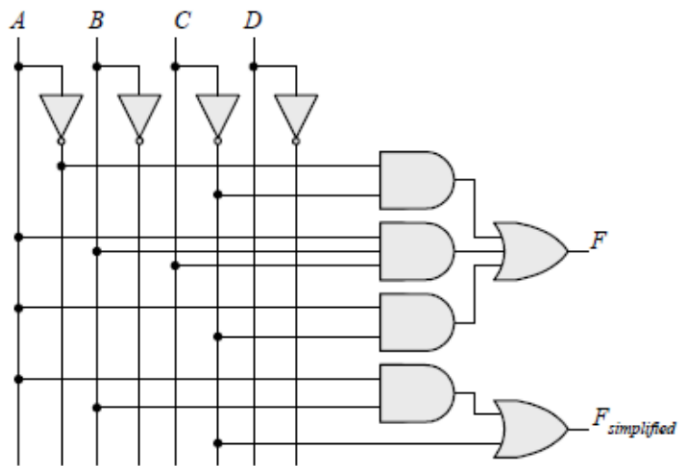

(b)

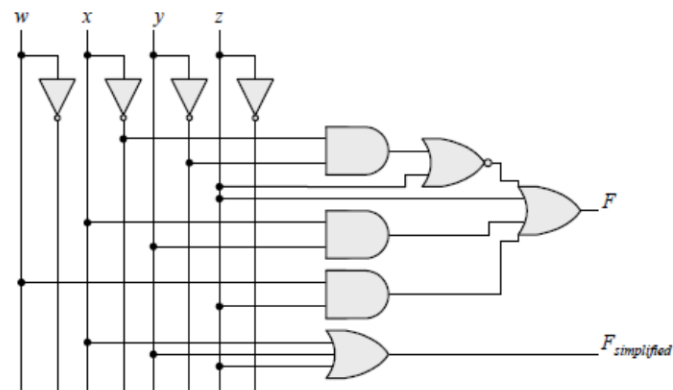

(c)

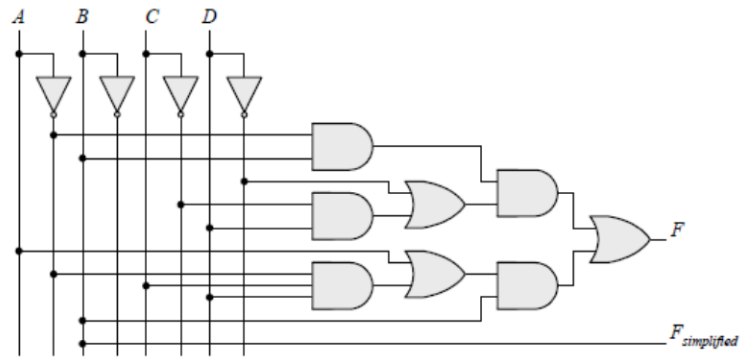

(d)

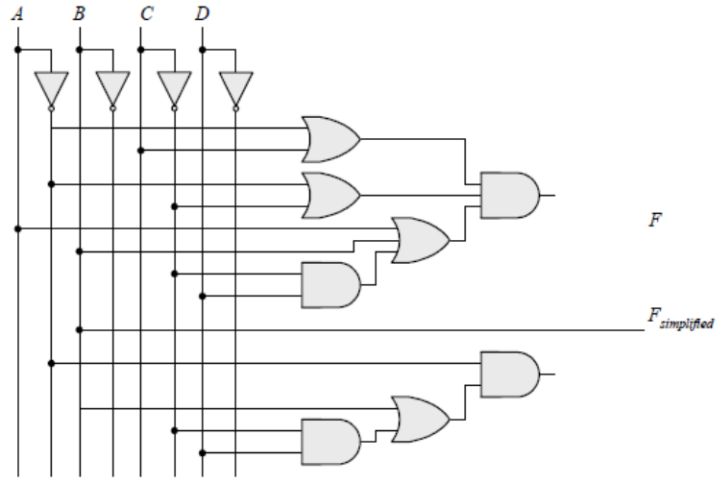

(e)

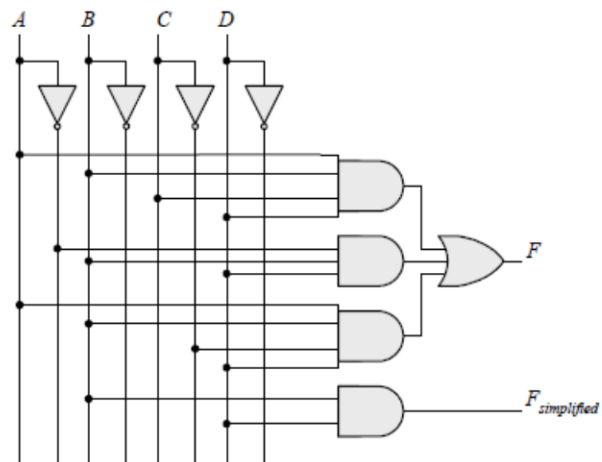

**2.9**

(a)  $F' = (xy' + x'y)' = (xy')'(x'y)' = (x' + y)(x + y') = xy + x'y'$

(b)  $F' = [(a + c)(a + b')(a' + b + c)]' = (a + c)' + (a + b')' + (a' + b + c)'$   
 $= a'c' + a'b + ab'c$

(c)  $F' = [z + z'(v'w + xy)]' = z'[z'(v'w + xy)]' = z'[z'v'w + xyz]'$   
 $= z'[(z'v'w)'(xyz)'] = z'[(z + v + w')(x' + y' + z)]$   
 $= z'(v + w')(x' + y')$

**2.11**

(a)  $F(x, y, z) = \odot(1, 4, 5, 6, 7)$

(b)  $F(a, b, c) = \odot(0, 2, 3, 7)$

$F = xy + xy' + y'z$	
x y z	F
0 0 0	0
0 0 1	1
0 1 0	0
0 1 1	0
1 0 0	1
1 0 1	1
1 1 0	1
1 1 1	1

$F = bc + a'c'$	
a b c	F
0 0 0	1
0 0 1	0
0 1 0	1
0 1 1	1
1 0 0	0
1 0 1	0
1 1 0	0
1 1 1	1

**2.13 (a)**

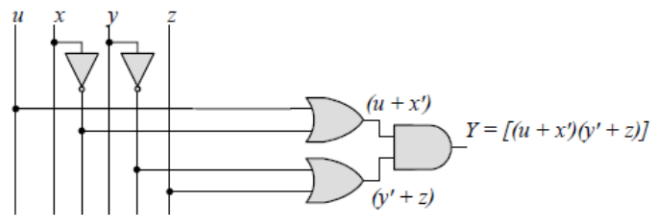

**(b)**

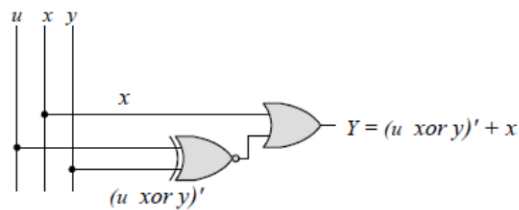

(c)

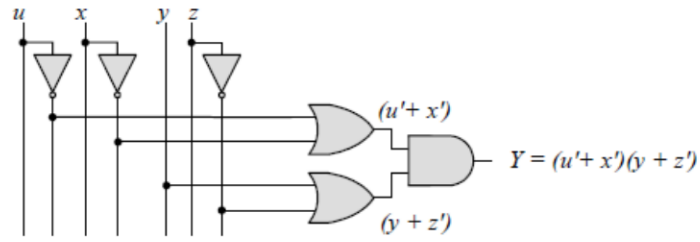

(d)

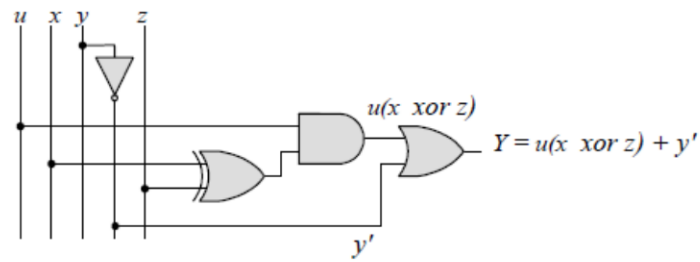

(e)

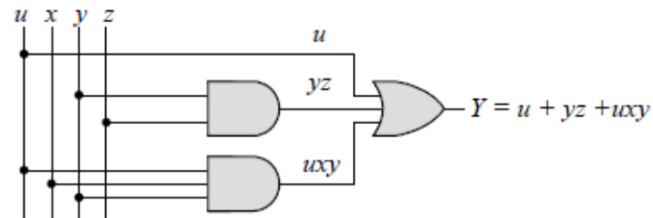

(f)

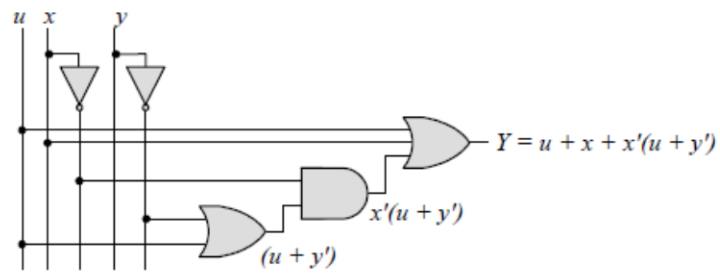

2.14 (a)

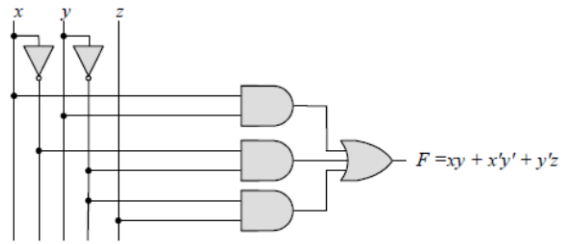

(b)

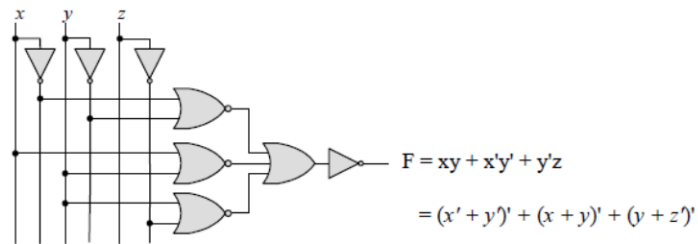

(c)

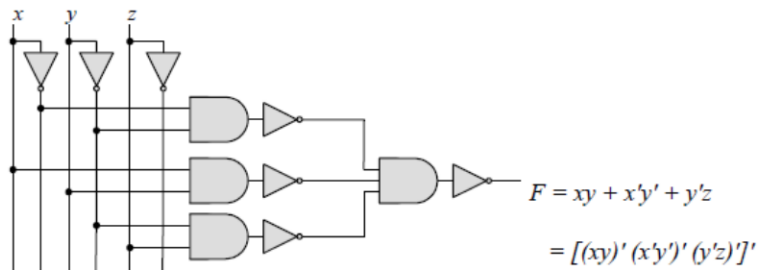

(d)

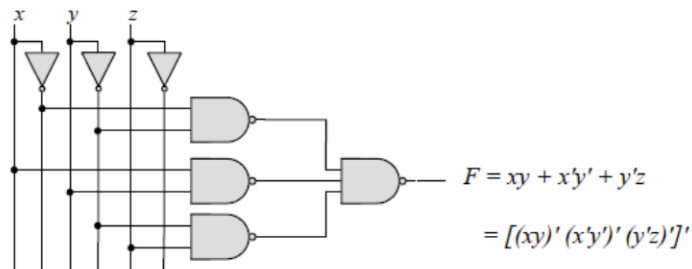

(e)

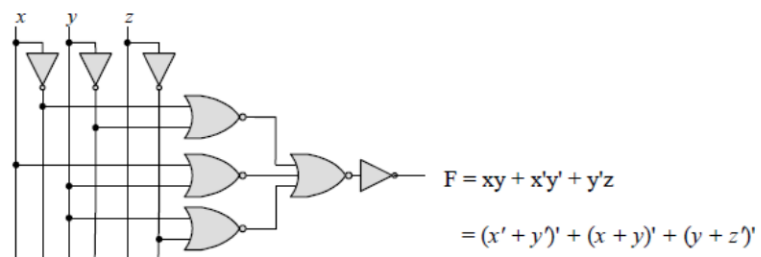

2.18

(a)

wx y z	F	$F = xy'z + x'y'z + w'xy + wx'y + wxy$ $F = \Sigma(1, 5, 6, 7, 9, 10, 11, 13, 14, 15)$
00 0 0	0	
00 0 1	1	
00 1 0	0	
00 1 1	0	
01 0 0	0	
01 0 1	1	
01 1 0	1	
01 1 1	1	
10 0 0	0	
10 0 1	1	
10 1 0	1	
10 1 1	1	
11 0 0	0	
11 0 1	1	
11 1 0	1	
11 1 1	1	

(b)

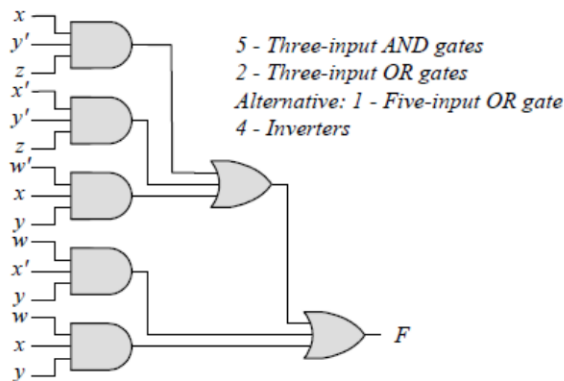

(c)  $F = xy'z + x'y'z + w'xy + wx'y + wxy = y'z + xy + wy = y'z + y(w + x)$

(d)  $F = y'z + yw + yx = \Sigma(1, 5, 9, 13, 10, 11, 13, 15, 6, 7, 14, 15)$   
 $= \Sigma(1, 5, 6, 7, 9, 10, 11, 13, 14, 15)$

(e)

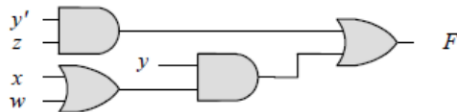

1 - Inverter, 2 - Two-input AND gates, 2 - Two-input OR gates