Chapter 5

Synchronous Sequential Logic

- A digital system is composed of
 - registers
 - data processing units
- Binary information is transferred from one set of registers into another
- Transfer can be done directly or via a processing unit to perform an operation

Registers

- A register is a group of *Binary cells*
- a register with n cells can store n bits

Example:

- Register with 8 cells can store 8 bits and can be in one of 2^8 possible states

0	0	0	0	0	0	1	1
---	---	---	---	---	---	---	---

The content is a function of the interpretation given to the information stored in to it. Here it's the positive integer (+3)

Registers

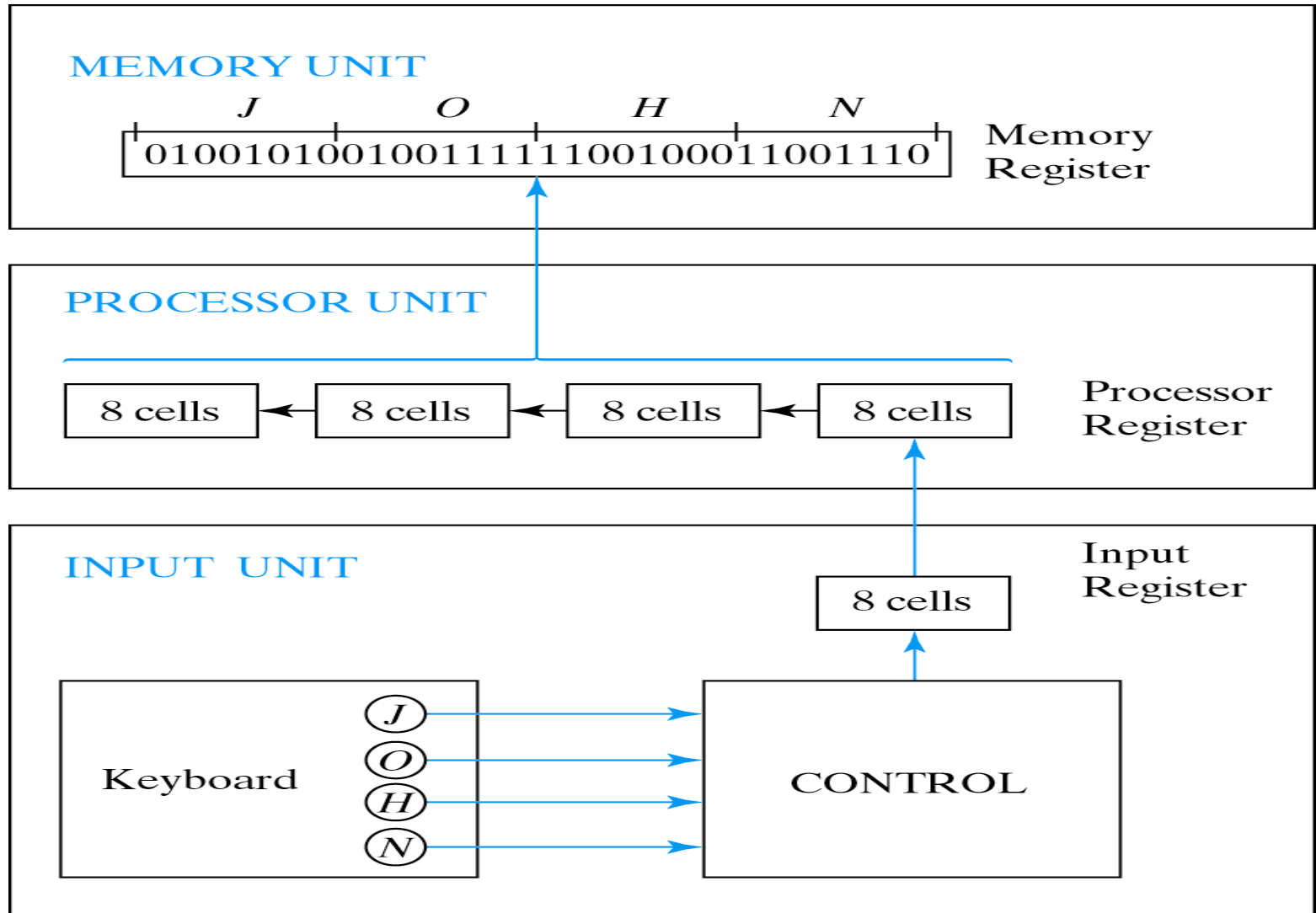

Fig. 1-1 Transfer of information with registers

Registers

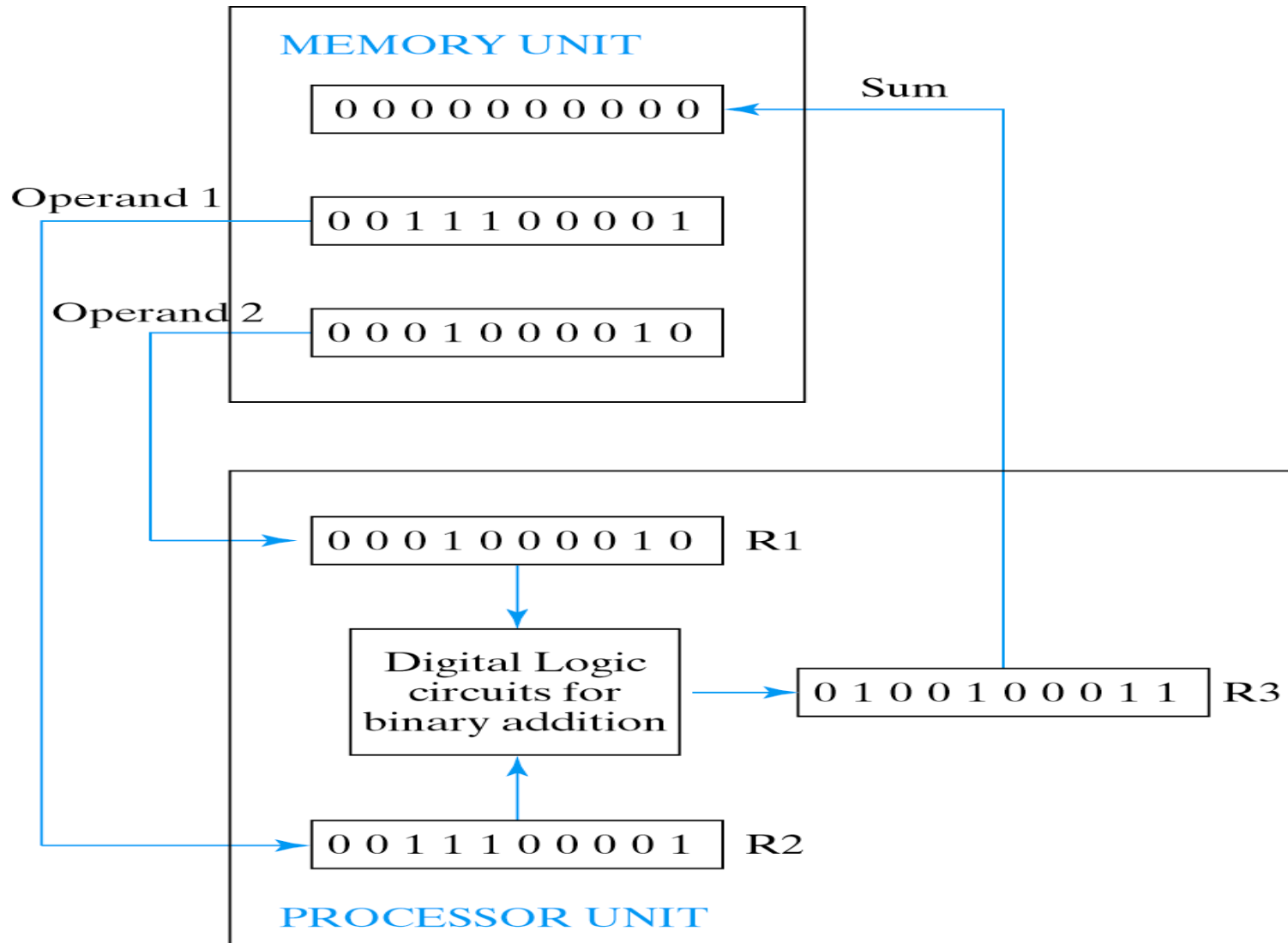

Fig. 1-2 Example of binary information processing

Sequential Circuits

- outputs logical functions of inputs and previous history of circuit (memory)
- after changed inputs, new outputs appear in the next clock cycle
- feedback loops

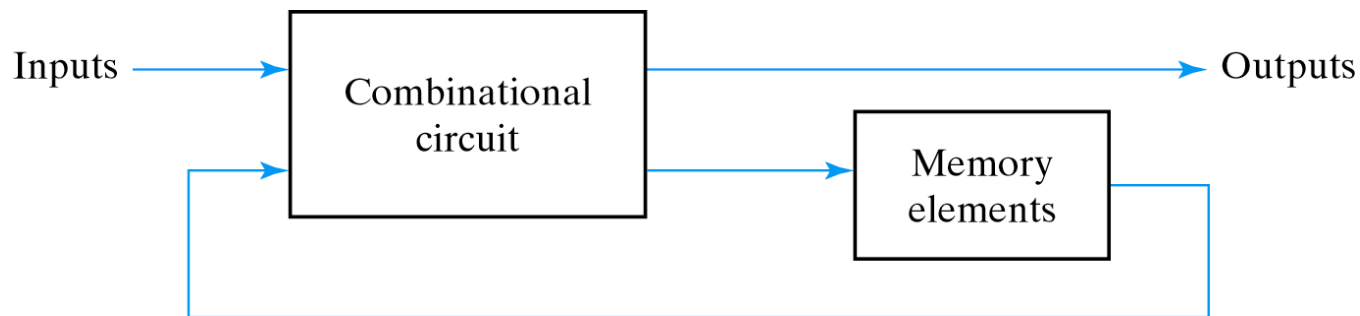
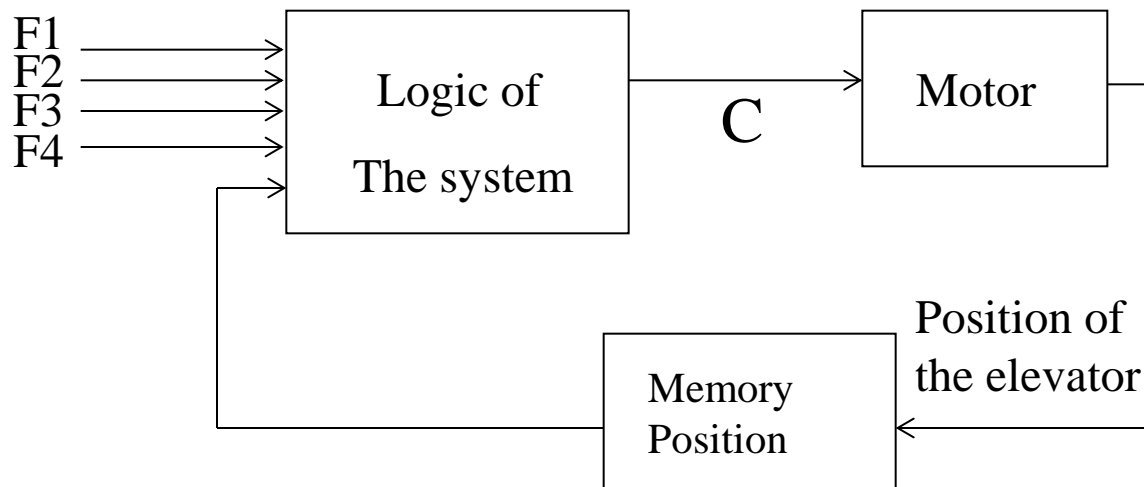

Fig. 5-1 Block Diagram of Sequential Circuit

Sequential logic circuits -Example

-- Elevator Control --

- The buttons are the input variables of the system
- The position is also an input variable which represents the current state of the elevator.
- in the figure the command control 'C' depends on the button selection AND and the position of the elevator (I.e. the previous state of the system: before the activation of the buttons)



Sequential logic circuits –Example (2)

-- Elevator Control --

This example represents a **Sequential** logic system That is the output C depends on combination of

1 – **the input variables**

2 – **AND the previous states** (internal states).

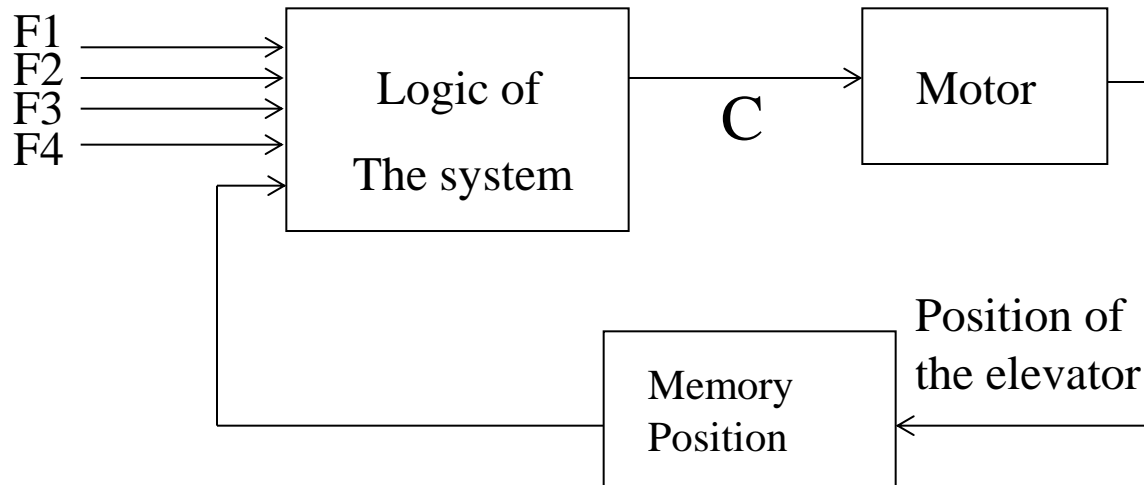

Sequential circuits: time and memory

→ *In contrast to the combinational circuits* two new parameters are to be considered

1 - *Time*

We have to consider the propagation delay of the circuits

2 – *Memory Element*

We have to keep the previous results and impose a predetermined order.

→ Generally speaking, the function performed by the memory element is to store information in a binary form.

Sequential logic circuits : Flip-flop

- The memory cell that stores one "bit" of information is termed Flip-flop.
- A set of Flip-flop can be used to store several bits (one each) in a REGISTER.
- two different modes:
 - 1- Asynchronous
 - 2- Synchronous

Sequential logic circuits

1- Asynchronous

- The output reacts "immediately" to the changes of the input variables

→ Propagation delay of the gates are to be considered

--- $> t_p$

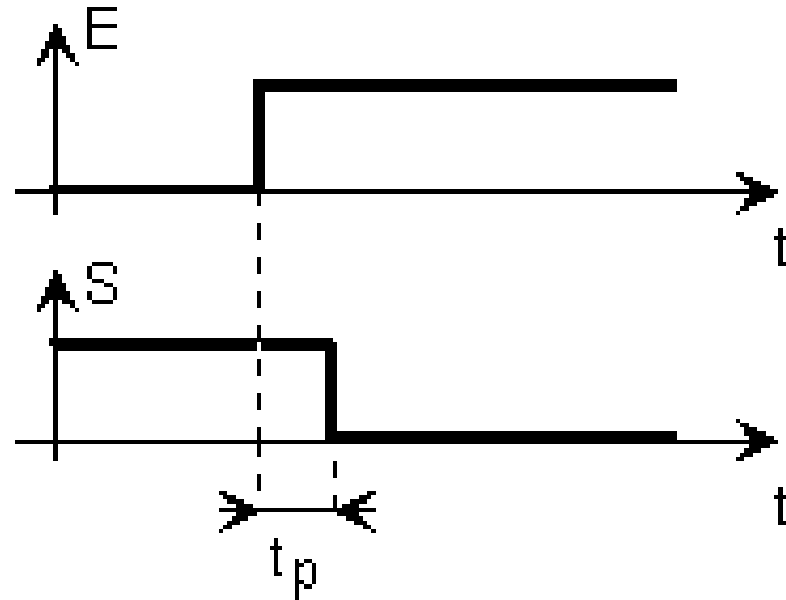
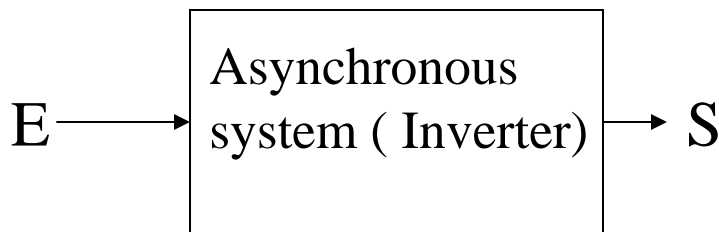

Sequential logic circuits

2- Synchronous

- In this mode of operation, changes of the input variables will be become **EFFECTIVE** when the clock input is active.

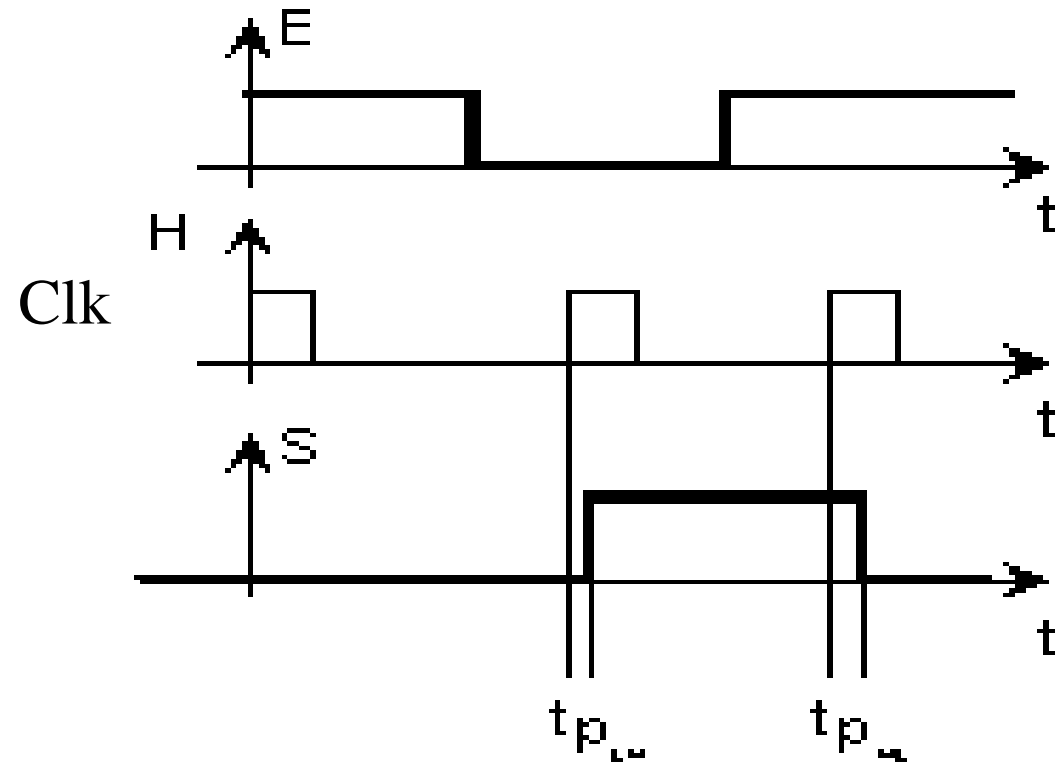
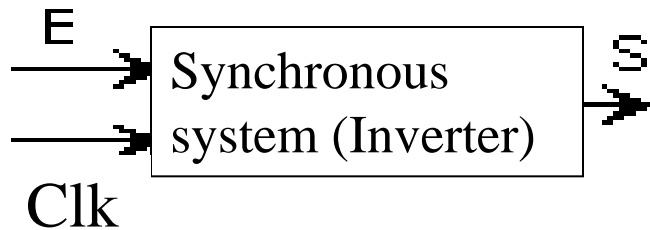

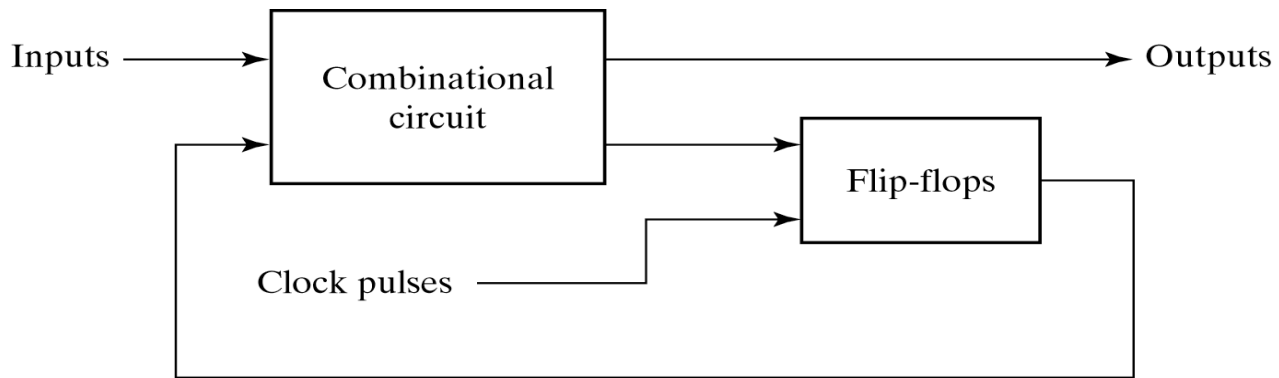

(a) Block diagram



(b) Timing diagram of clock pulses

Fig. 5-2 Synchronous Clocked Sequential Circuit

Clock signal : definitions

- Clock is used in synchronous logic circuits to trigger the circuit (**Flip-flop**) allowing it to switch its state.
- Clock signal can trigger a flip-flop in three ways:
 - **During Positive level**
 - **During Positive transition (or positive edge)**
 - **During Negative transition (or negative edge)**

Timing Diagram –Input and output signals

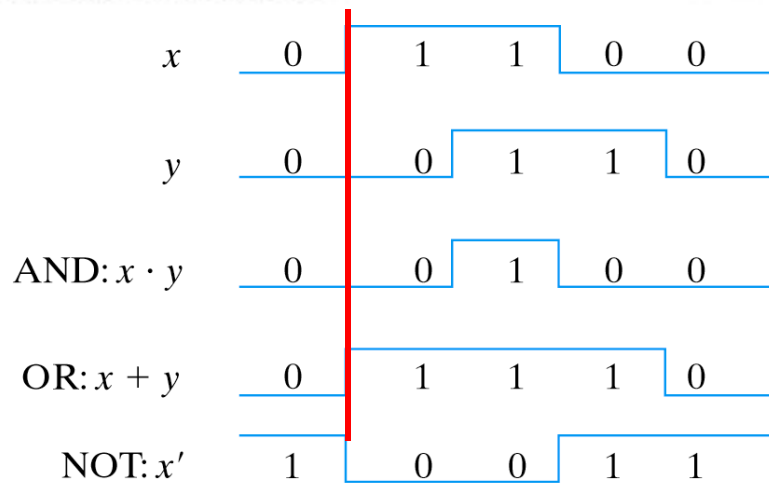
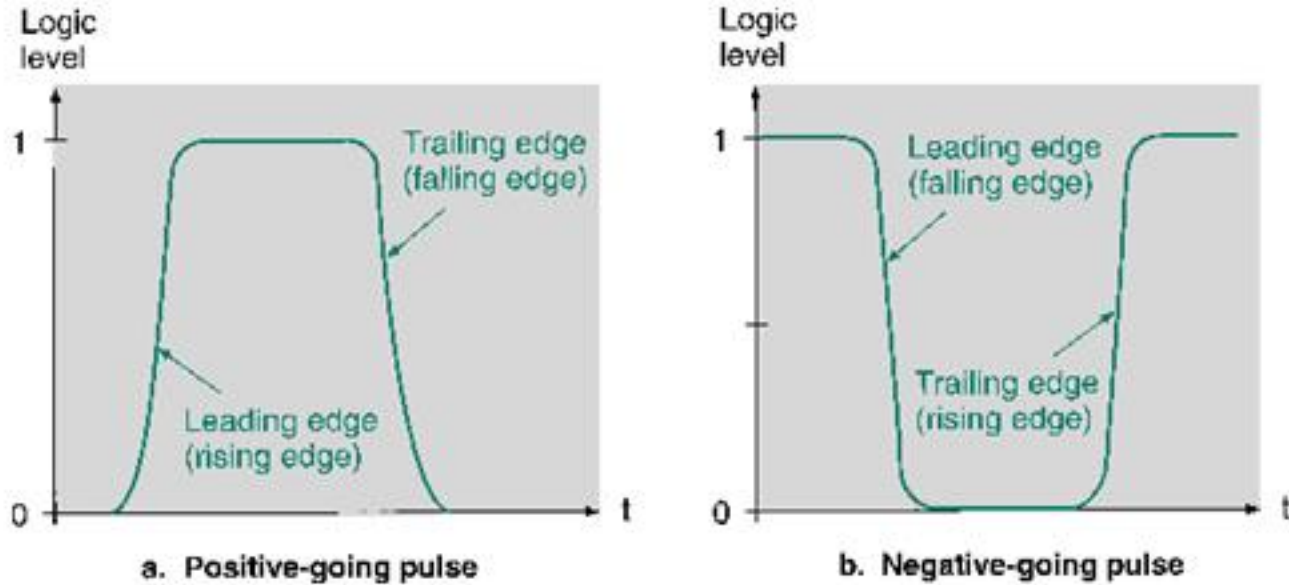
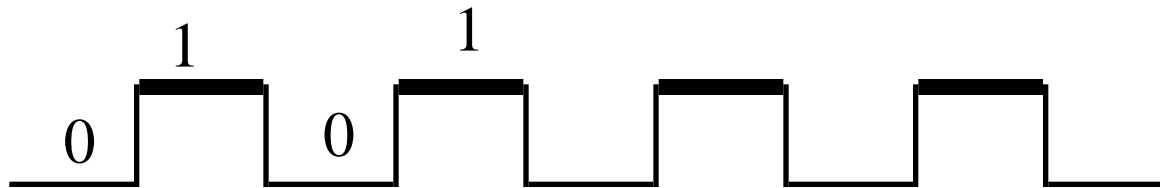

Fig. 1-5 Input-output signals for gates

Clock signal : definitions

1- Positive level

- The flip-flop is triggered while the clock pulse is at logic '1'
- the logic '0' is therefore inactive state where changes to the flip-flop (state) are not allowed.



Clock signal : definitions (2)

2- Positive transition (or positive edge)

The flip flop is triggered only during the signal transition from 0 to 1 , this transition is defines as *positive edge*

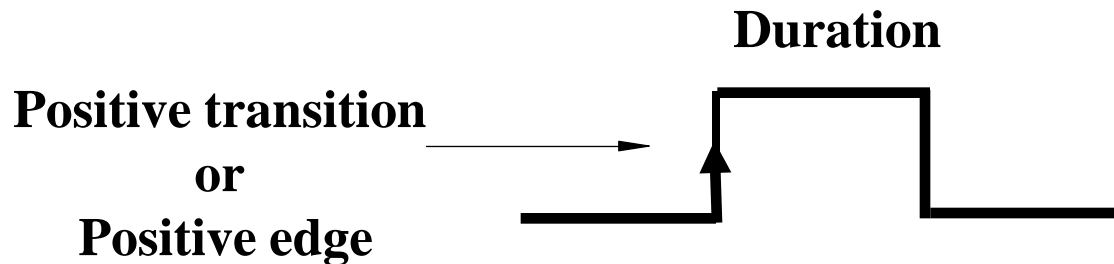
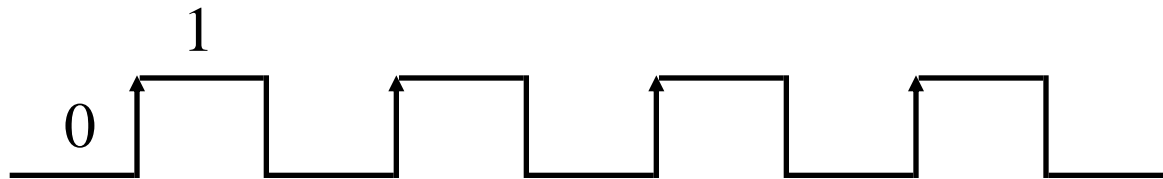

Clock signal : definitions (4)

3- negative transition (or negative edge)

The flip flop is triggered only during the signal transition from **1 to 0**, this transition is defines as *negative edge*

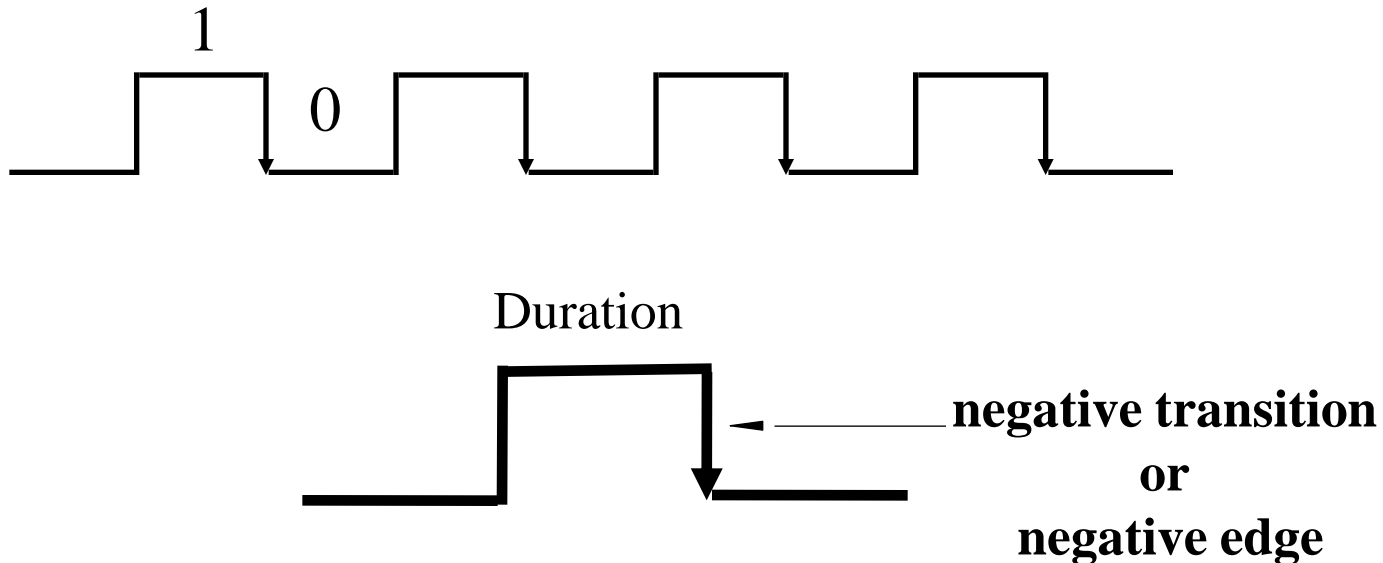

Memory Element (Latch)

- **A flip-flop** can maintain a binary state indefinitely until directed by an input signal to switch states
- The most basic types of flip-flops operate with signal levels and are referred to as **Latches**.
- **Latches** are basic circuits from which all flip-flops are constructed

Memory Element (SR Latch)

- **Flip-flop** (Latch) SR has two input variables that are defined as S and R
 - S for SET
 - R for RESET
- It also has two outputs Q (**normal state**) and Q' (**complement state**)

Symbol



Memory Element (SR Latch)

1- NOR Implementation

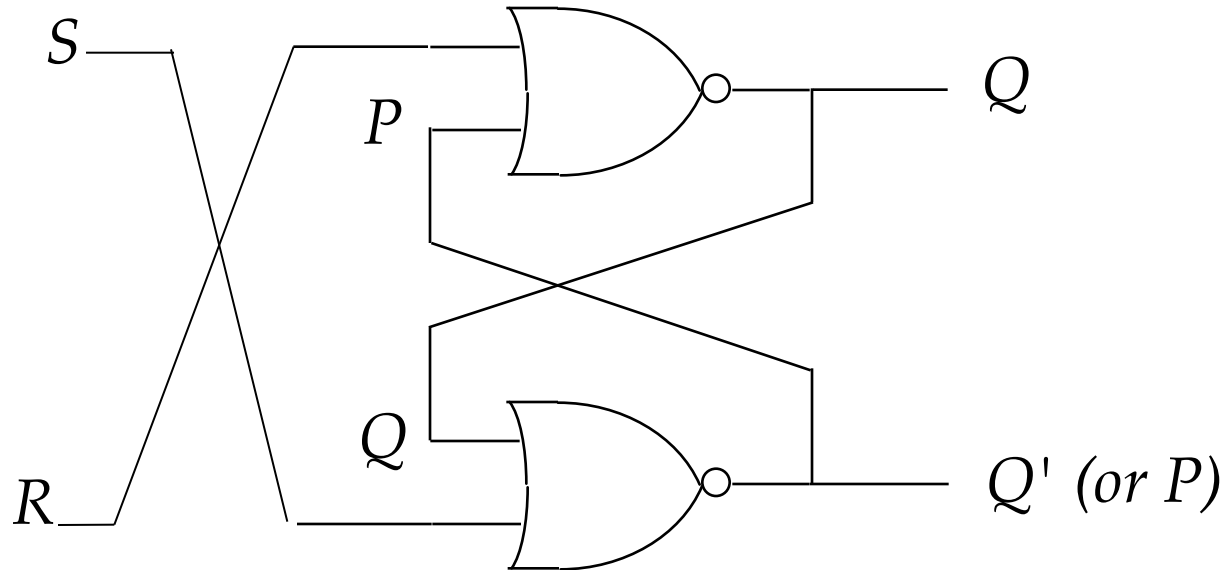

$$Q = (R+P)' = R'P'$$

$$P = (S+Q)' = S'Q'$$

Memory Element (SR Latch)



Symbol

Function table for RS with NOR gates

S	R	Q	Q'	
1	0	1	0	Set to "1"
0	1	0	1	Set to "0"
0	0	1	0	unchanged (after SR = 10)
0	0	0	1	unchanged (after SR = 01)
1	1	0	0	forbidden!

Memory Element (SR Latch)

2- Inverter and NAND Implementation

$$Q = (S'.P)' = S + P'$$

$$P = (R'.Q)' = R + Q'$$

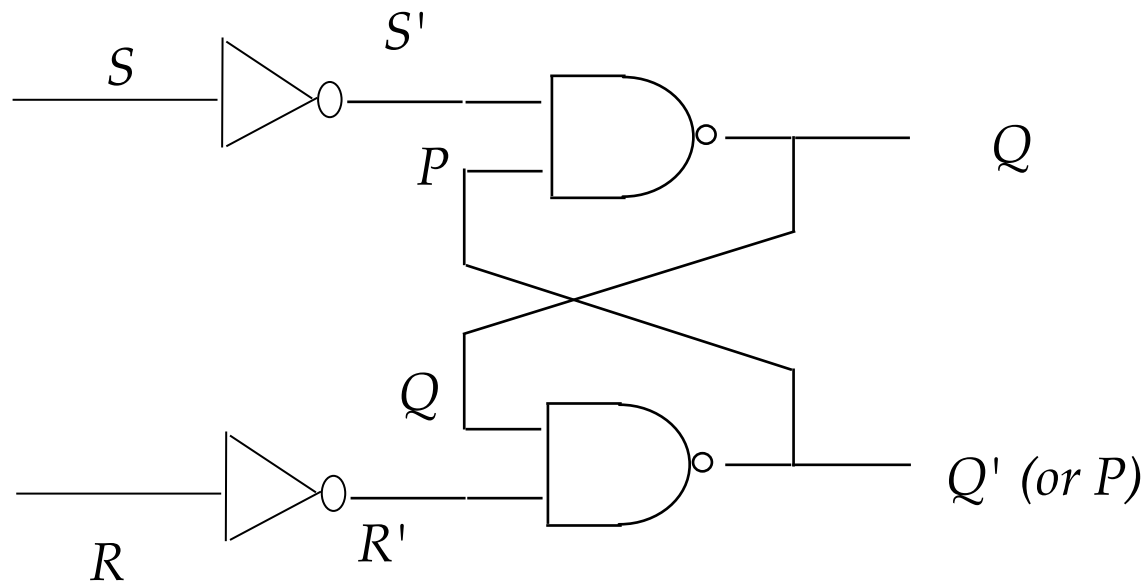

Memory Element (SR Latch)

Function table for RS with **Inverter and NAND** gates

S	R	Q	Q'	
1	0	1	0	Set to "1"
0	1	0	1	Set to "0"
0	0	1	0	unchanged (after SR = 10)
0	0	0	1	unchanged (after SR = 01)
1	1	1	1	forbidden!

Memory Element (SR Latch)

3- NAND Implementation **also called S'R' Latch**

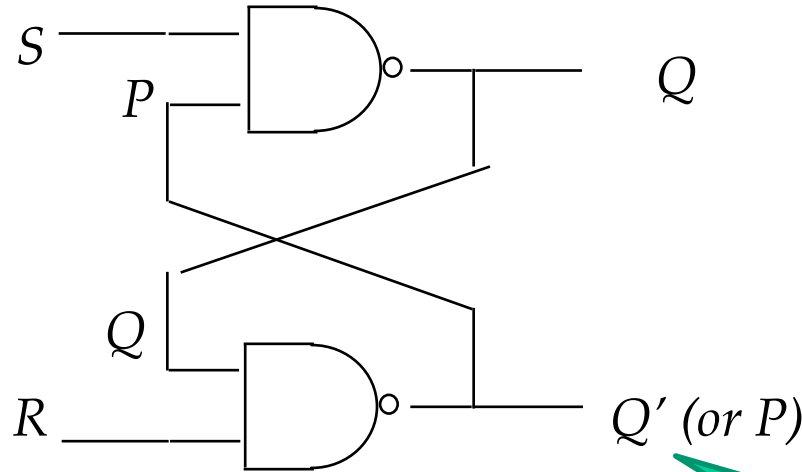

$$Q = S' + P'$$

$$P = R' + Q'$$

Function table for RS with NAND gates:

S	R	Q	Q'	R
1	0	0	1	set to « 0 »
1	1	0	1	unchanged (after SR = 10)
0	1	1	0	set to « 1 »
1	1	1	0	unchanged (after SR = 01)
0	0	1	1	Not allowed! (forbidden)

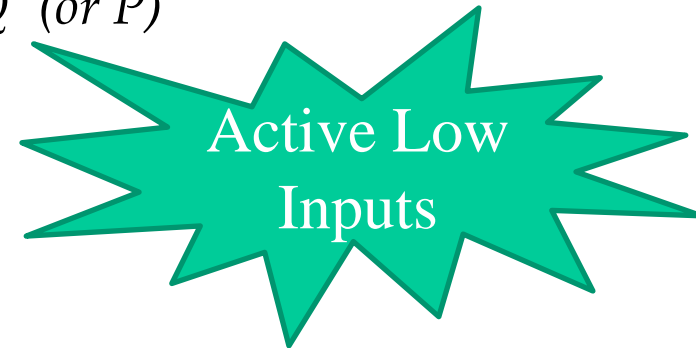

Synchronous Sequential Circuits

- If we add to the memory element a **synchronization signal** (i.e. clock impulse or control input) we would obtain a synchronous SR latch (i.e. a Flip-Flop)
- We will examine the following synchronous flip-flops
 - SR
 - D and T
 - JK

SR Latch with Control Input

- The time when a latch is allowed to change state is regulated.
- Change of state is regulated by a control signal called ENABLE.
- **Circuit is a NAND latch controlled by steering gates.**

Latch with Control Input: SR Latch

- Used in two principal ways.
 - as an ON/OFF signal.
 - as a synchronizing signal.

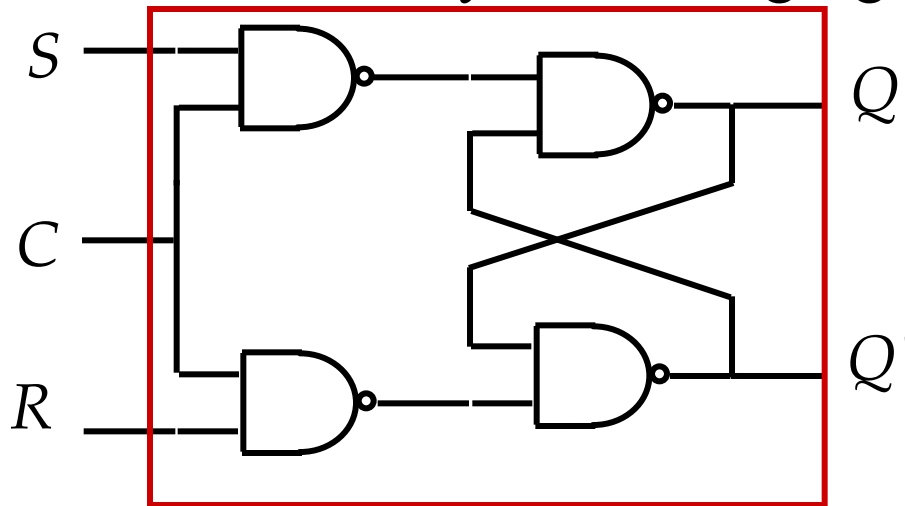

C	S	R	Q _{t+1}	Q' _{t+1}	Function
1	0	0	Q _t	Q' _t	No change
1	0	1	0	1	RESET
1	1	0	1	0	SET
1	1	1	1	1	Forbidden
0	X	X	Q _t	Q' _t	Inhibited.

- Sometimes it's useful to avoid latch changes

When C = 0 → disables all latch state changes

- Control signal *enables* state change when C = 1
- Right side of circuit same as ordinary S-R latch with NAND.

Latches with Control Input: D latch

- D for Data. Data is transferred to the Latch

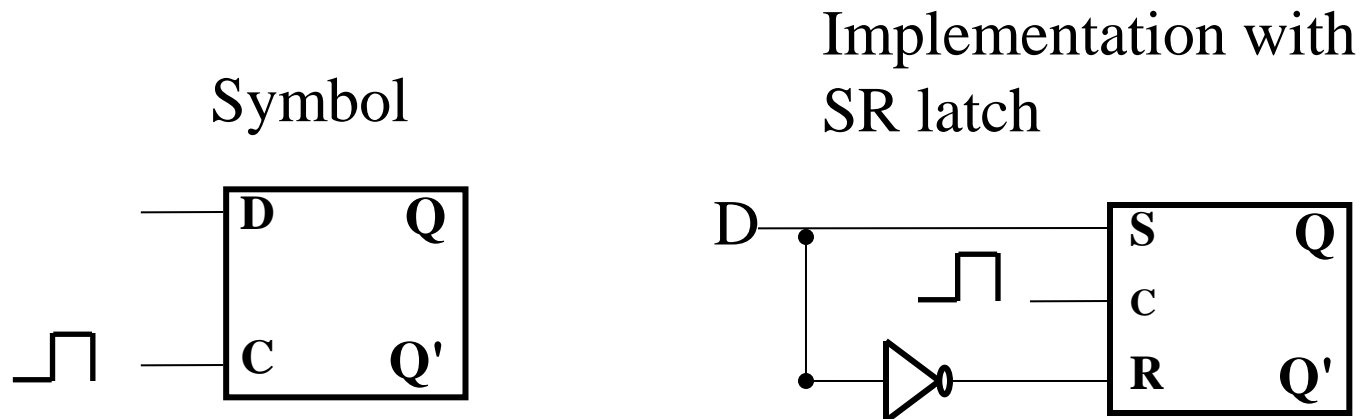

- **When C is high, D passes from input to output (Q)**

D	c	Q	Q'
0	1	0	1
1	1	1	0
X	0	Q_n	Q_n'

° Q_n : the previous state (the previously stored value)

°Q : the next state

Edge Sensitive Flip-Flop

- **Latches** respond to trigger **levels** on control inputs
 - Example: If **C = 1**, input is reflected at output
- **Flip flops** store data on **a positive or negative edge**.
 - Example: control input **transitions from 0 to 1**, data input available at output.
 - Data **remains stable** in the flip flop until next positive /negative edge.
- **Different types of flip flops are used for specific functions**

Edge Sensitive Flip-Flop: Definitions

- The sequential circuit output changes when its CLOCK input detects an edge. **Edge-sensitive** instead of **level-sensitive**.
- **Symbol is a triangle on the CLK (clock) input of a flip-flop.**
- Flip flop can be triggered on **positive** or **negative** edge
- **Bubble before Clock (CLK) input indicates negative edge trigger**

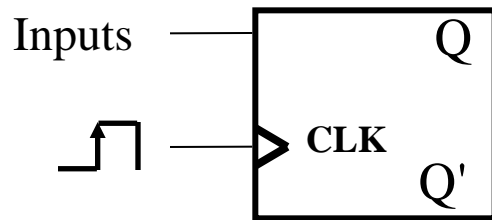

Symbol with positive edge

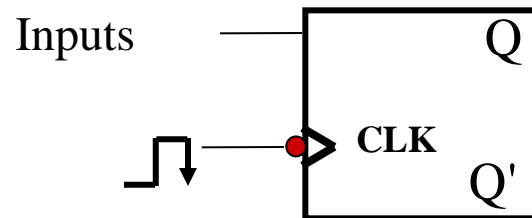

Symbol with negative edge

D Flip Flop - Clocking Event

- What if the output changed only on the **clock transition**?

Positive Edge Triggered

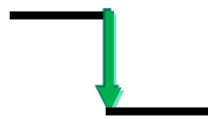
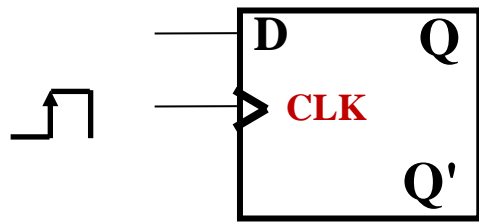

Hi-Lo edge

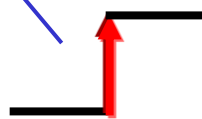

Lo-Hi edge

D	CLK	Q	Q'
0	↑	0	1
1	↑	1	0
X	0	Q_n	Q_n'

Q_n : the state before the positive edge

Q : the state after the positive edge

Master-Slave D Flip Flop

- Consider two latches combined together
- Only one C value active at a time
- Output changes on **falling** edge of the clock

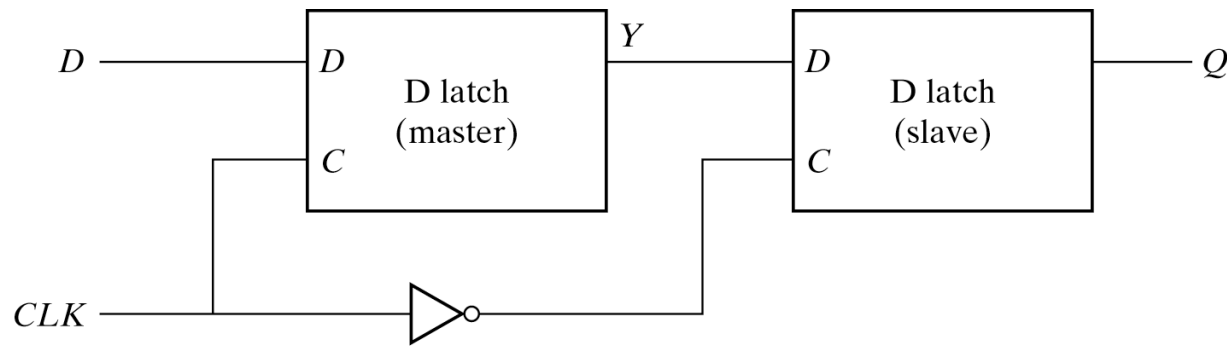
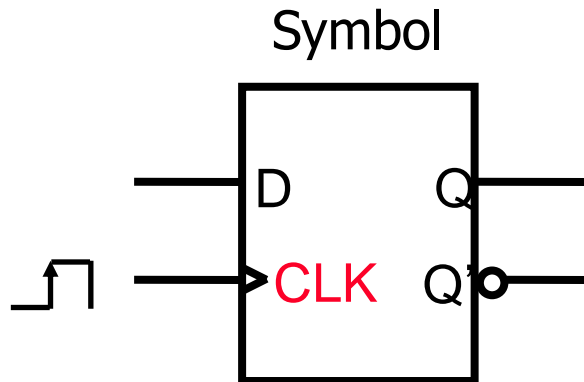

Fig. 5-9 Master-Slave D Flip-Flop

D Flip Flop

- Stores a value on the positive edge of *Clock*
- Input changes at other times have no effect on output



D	C	Q(t+1)
0	↑	0
1	↑	1
X	X*	Q(t)

°Q(t) : the state before the positive edge

°Q(t+1) : the state after the positive edge

°X* : other times

D gets **latched** to Q on the **rising edge** of the clock.

D Flip Flop

- Stores a value on the positive edge of *Clock*
- Input changes at other times have no effect on output

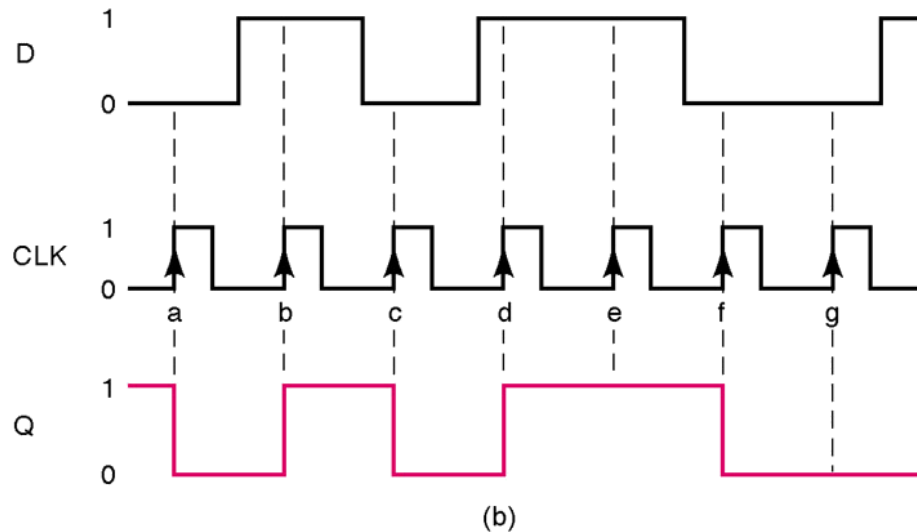
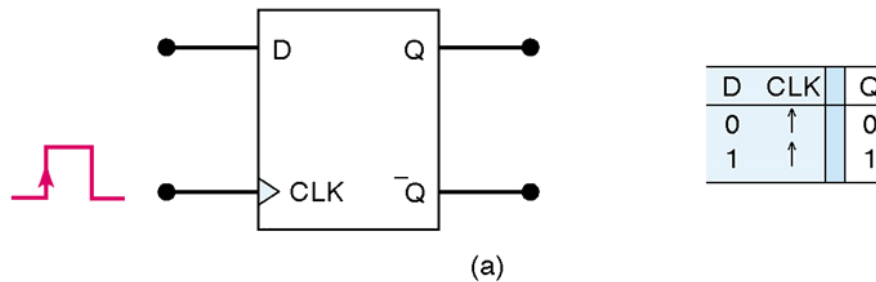

JK Flip flop

Positive Edge-Triggered J-K Flip-Flop

$$D = JQ' + K'Q$$

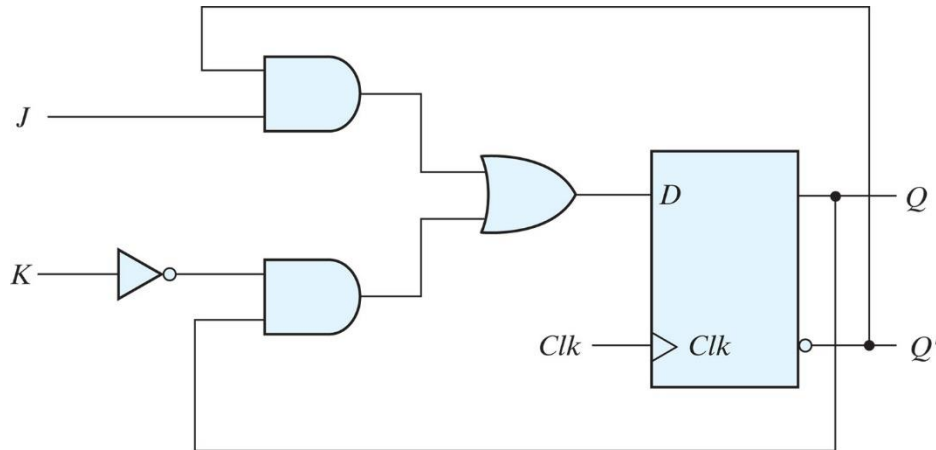

(a) Circuit diagram

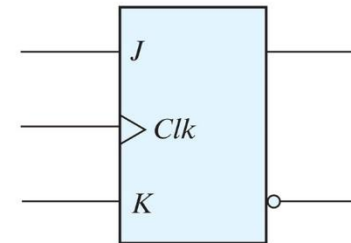

(b) Graphic symbol

Copyright ©2013 Pearson Education, publishing as Prentice Hall

° Created from D flip-flop

° J sets

° K resets

° J=K=1 -> invert output

J	K	C	Q(n+1)	Function
0	0	↑	Q(n)	No Change
0	1	↑	0	Reset
1	0	↑	1	Set
1	1	↑	Q'(n)	Toggle
x	x	x	Q(n)	No Change

• Q_n : state *before* positive edge

• $Q_{(n+1)}$: state *after* positive edge

J-K Flip-Flop Implementations

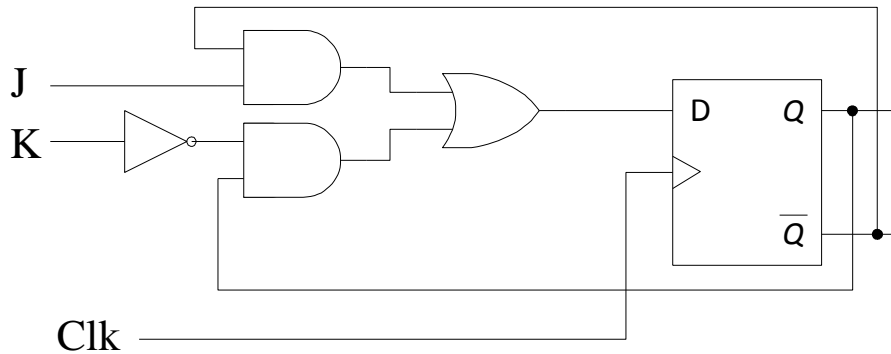

$$D = JQ' + K'Q$$

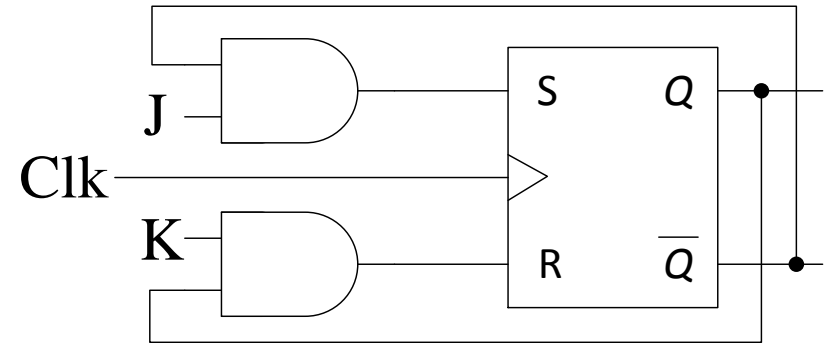

$$S = JQ'$$

$$R = KQ$$

J	K	D	Q(n+1)	Comment
0	0	Q	Q(n)	
0	1	0	0	0 + 0
1	0	1	1	Q'+Q
1	1	Q'	Q'(n)	

J	K	S	R	Q(n+1)	Comment
0	0	0	0	Q(n)	
0	1	0	Q	0	If Q 1, reset to 0.
1	0	Q'	0	1	If Q 0, set to 1.
1	1	Q'	Q	Q'(n)	S,R = 0,1 (Q=1), Reset S,R = 1,0 (Q=0), Set

Characteristic Table

JK Flip flop

- Two data inputs, J and K
- J \rightarrow set, K \rightarrow reset, if J=K=1 then toggle (complement) output

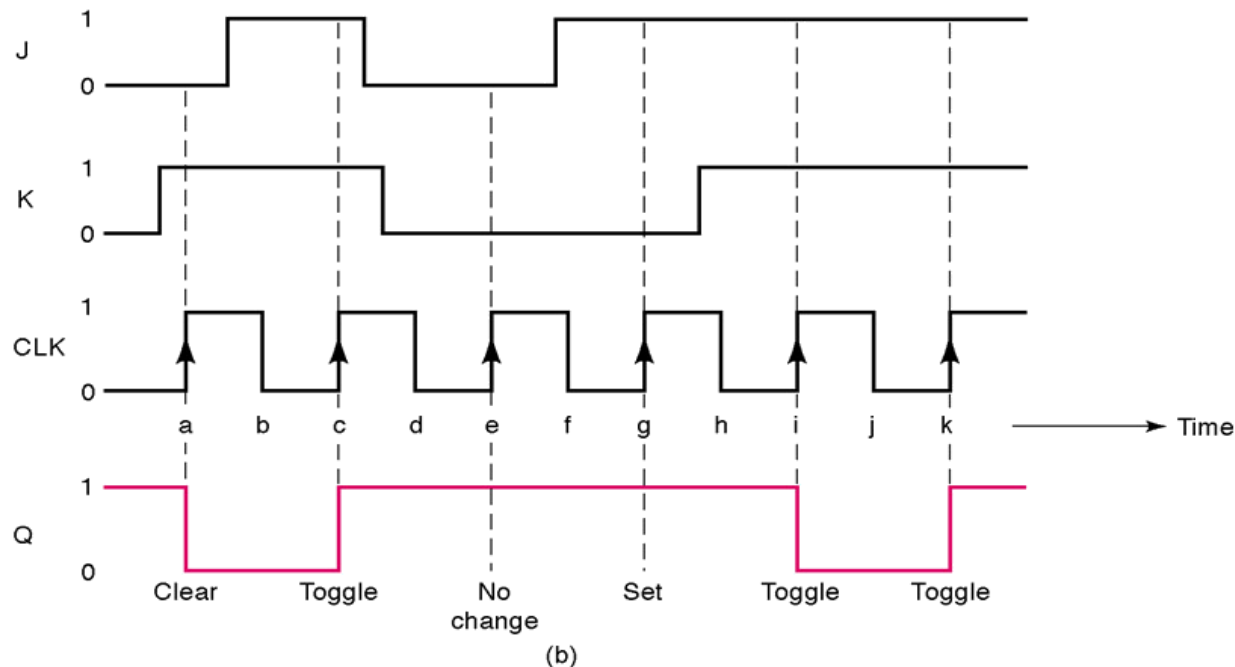
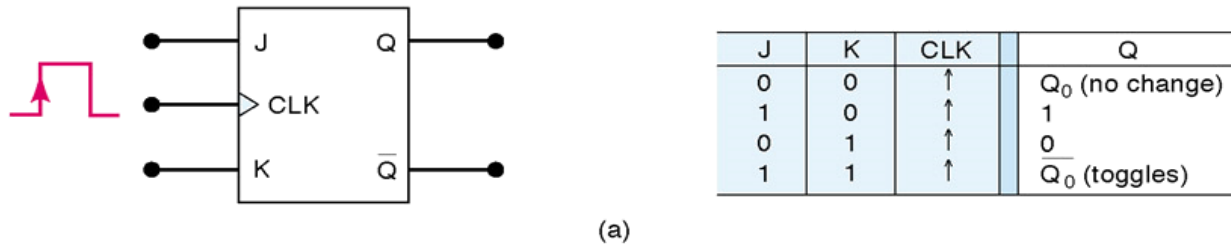

T Flip-Flop

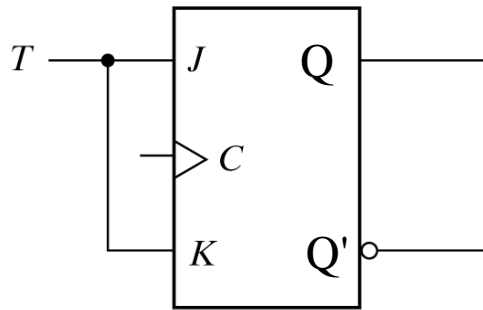

(a) From JK flip-flop

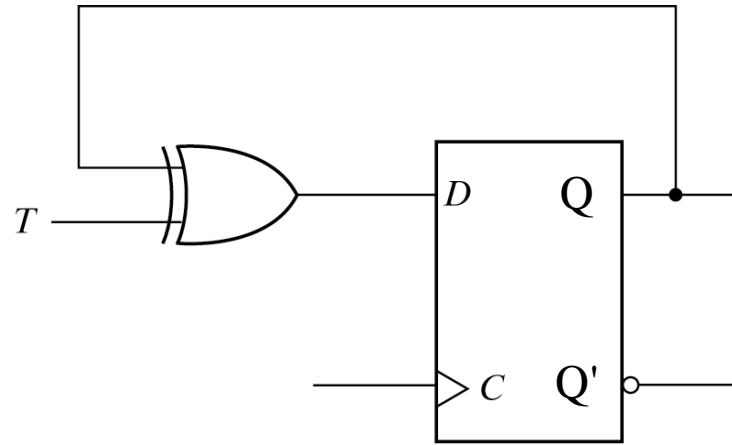

(b) From D flip-flop

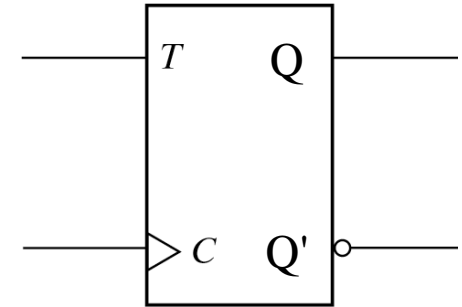

(c) Graphic symbol

Fig. 5-13 T Flip-Flop

°Can be Created from JK or D flip flop

T	C	Q(t+1)
0	↑	Q(t) No change
1	↑	Q'(t) Complement (Toggle)

$$D = T \oplus Q$$

$$= TQ' + T'Q$$

Asynchronous Inputs

- So far we have only considered **synchronous inputs** (e.g. D, S, R, J, K). Their Effects on the output are synchronized with the *CLK* input.
- **Flip flops have asynchronous inputs.** They operate independently of the synchronous inputs and clock
 - used to Set the Flip flop to 1 or 0 state *at any time*.

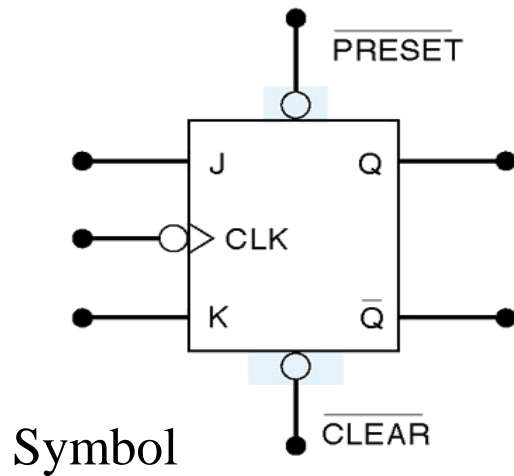

$\overline{\text{PRESET}}$	$\overline{\text{CLEAR}}$	FF response
1	1	Clocked operation*
0	1	Q = 1 (regardless of CLK)
1	0	Q = 0 (regardless of CLK)
0	0	Not used

*Q will respond to J, K, and CLK

Latch (Controlled) Summary

SR Latch

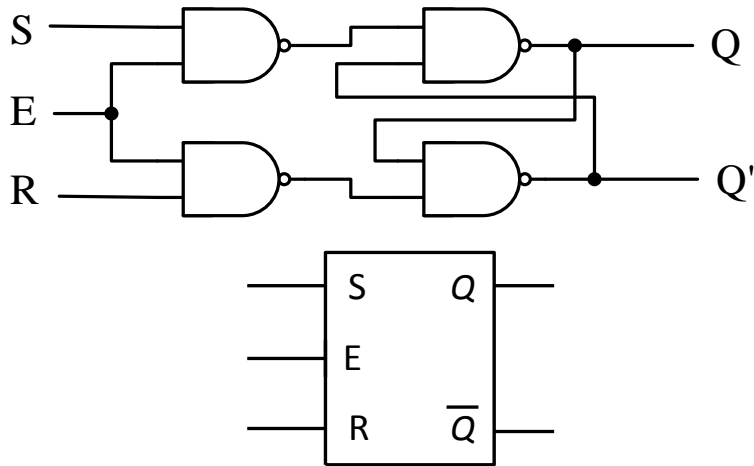

Function Table

S	R	E	Q(n+1)	Q'(n+1)	Comment
0	0	1	Q(n)	Q'(n)	No change
0	1	1	0	1	Reset
1	0	1	1	0	Set
1	1	1	?	?	Forbidden
x	x	0	Q(n)	Q'(n)	No change

D Latch

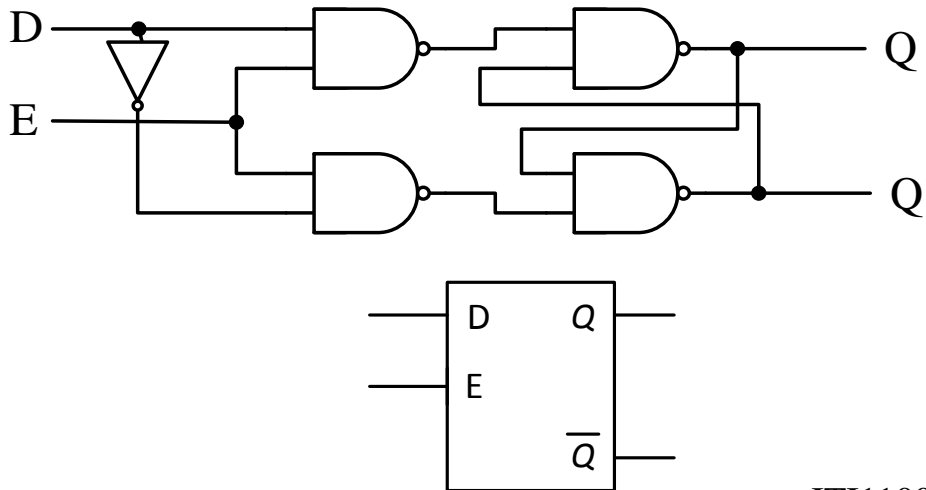

Function Table

D	E	Q(n+1)	Q'(n+1)	Comment
0	1	0	1	
1	1	1	0	
x	0	Q(n)	Q'(n)	No change

Flip-Flop Summary – Symbols/Function Tables

- Q_n = state *before* positive edge
- Q_{n+1} = state *after* positive edge

SR Flip-Flop

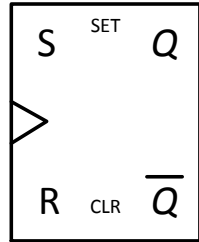

S	R	C	Q(n+1)	Q'(n+1)	Comment
0	0	↑	Q(n)	Q'(n)	No Change
0	1	↑	0	1	Reset
1	0	↑	1	0	Set
1	1	↑	?	?	Forbidden
x	x	0/1	Q(n)	Q'(n)	No Change

D Flip-Flop

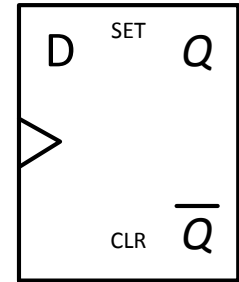

D	Clock	Q(n+1)	Q'(n+1)	Comment
0	↑	0	1	
1	↑	1	0	
x	0/1	Q(n)	Q'(n)	No Change

JK Flip-Flop

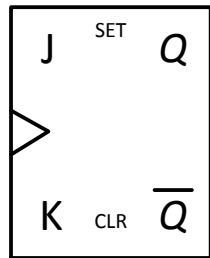

J	K	C	Q(n+1)	Comment
0	0	↑	Q(n)	No Change
0	1	↑	0	Reset
1	0	↑	1	Set
1	1	↑	Q'(n)	Toggle
x	x	0/1	Q(n)	No Change

T Flip-Flop

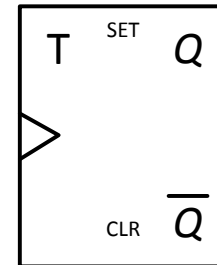

T	C	Q(n+1)	Q'(n+1)	Comment
0	↑	Q(n)	Q'(n)	
1	↑	Q'(n)	Q(n)	Complement (toggle)
x	0/1	Q(n)	Q'(n)	No change in output

Flip-Flop Summary – Characteristic Table/Function

SR Flip-Flop

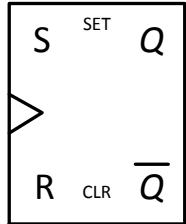

$$Q(t+1) = S + (R'Q)$$

S	R	Q(t+1)	Comment
0	0	Q(t)	No change
0	1	0	Reset
1	0	1	Set
1	1	Undef.	Forbidden

JK Flip-Flop

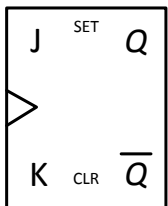

$$Q(t+1) = JQ' + K'Q$$

J	K	Q(t+1)	Comment
0	0	Q(t)	No Change
0	1	0	Reset
1	0	1	Set
1	1	Q'(t)	Complement

D Flip-Flop • Q(t) = state *before* positive edge

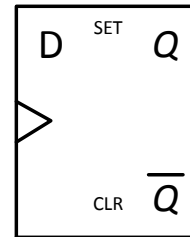

• Q(t+1) = state *after* positive edge

$$Q(t+1) = D$$

D	Q(t+1)	Comment
0	0	Reset
1	1	Set

T Flip-Flop

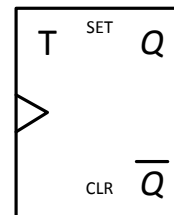

$$Q(t+1) = TQ' + T'Q = T \oplus Q$$

T	Q(t+1)	Comment
0	Q(t)	No change
1	Q'(t)	Complement (toggle)

Example: an application of Flip flops

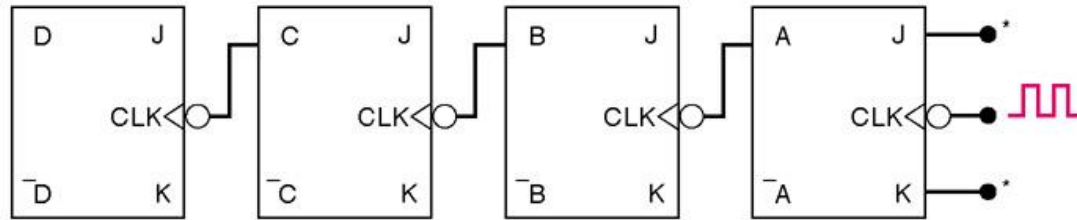

*All J and K inputs assumed to be 1.

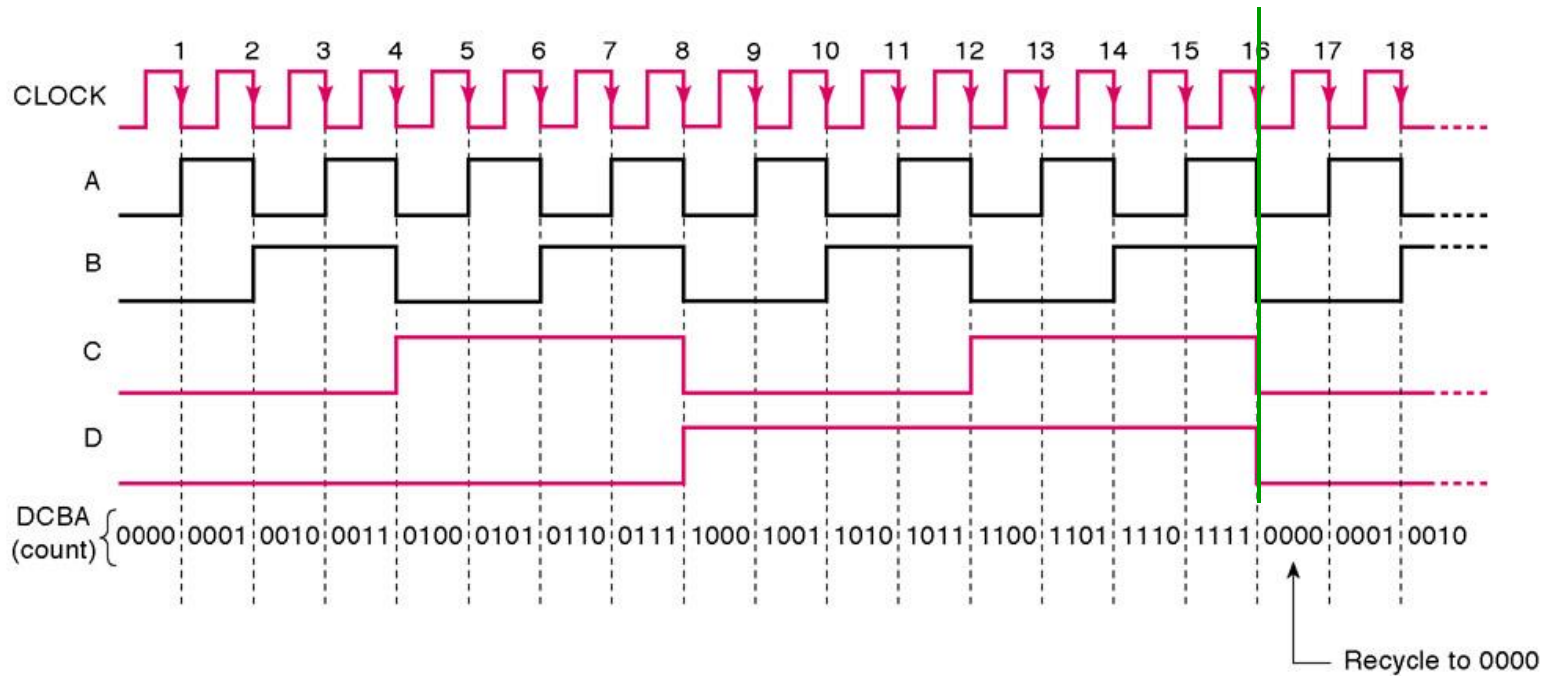

Analysis of synchronous sequential circuits

→ Analysis describes what a given circuit will do under certain conditions

→ Behavior of synchronous sequential circuit can be determined from

- Its inputs,

- Its outputs and its Flip Flop state

Flip Flop State

- Behavior of synchronous sequential circuit can be determined from inputs, outputs and Flip Flop state

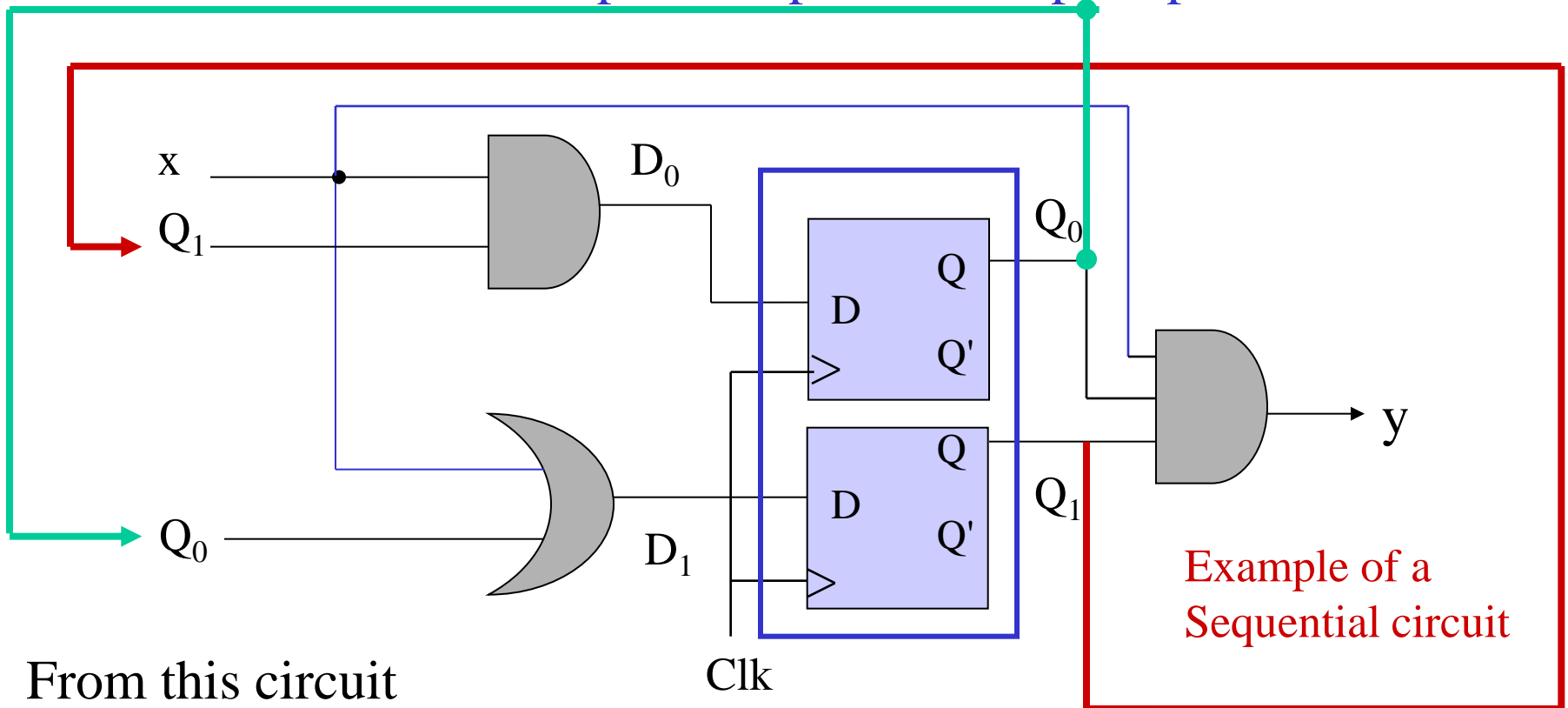

$$y(t) = x(t)Q_1(t)Q_0(t)$$

$$Q_0(t+1) = D_0(t) = x(t)Q_1(t)$$

$$Q_1(t+1) = D_1(t) = x(t) + Q_0(t)$$

Output and State Equations

- Next state dependent on previous state.

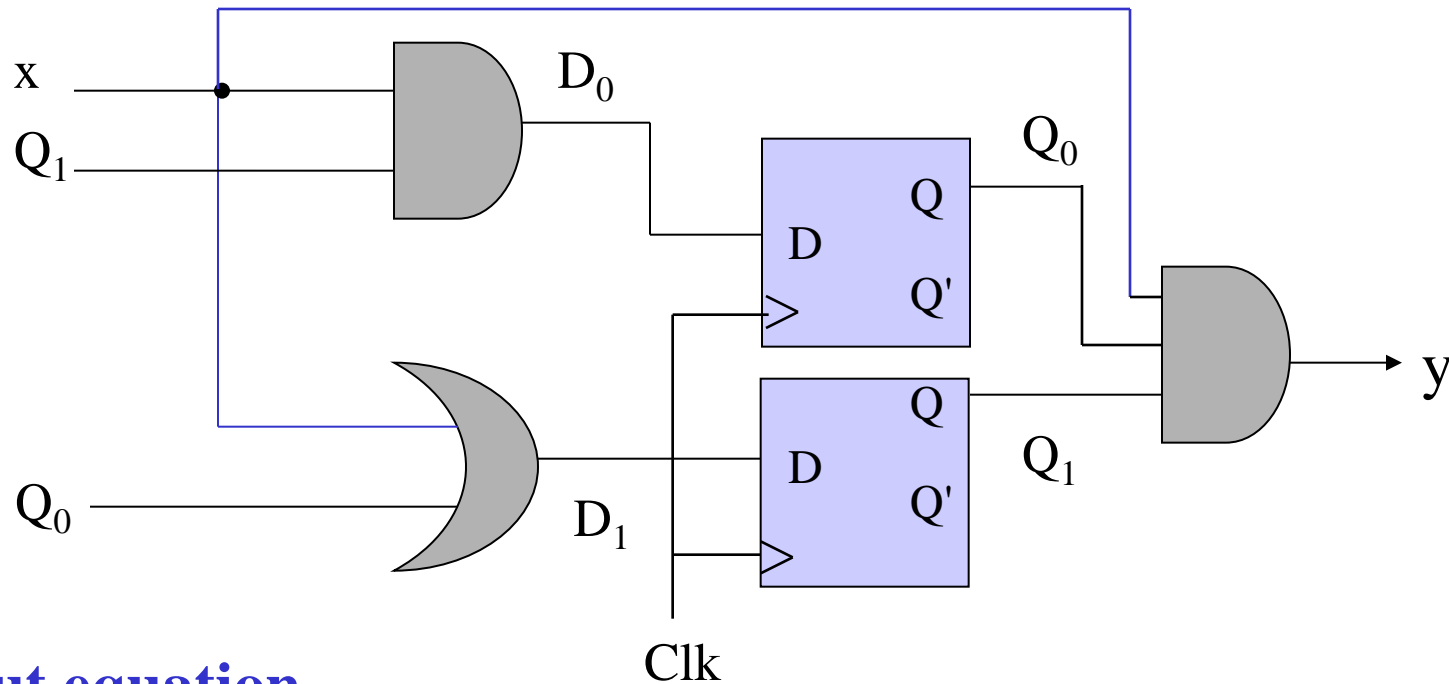

Output equation

$$y(t) = x(t)Q_1(t)Q_0(t)$$

State equations

$$Q_0(t+1) = D_0(t) = x(t)Q_1(t)$$

$$Q_1(t+1) = D_1(t) = x(t) + Q_0(t)$$

State Table

- Sequence of outputs, inputs, and flip flop states are listed in a table called “State Table”
- **Present state** indicates current value of flip flops
- **Next state** indicates state after next clock edge
- **Output** is output value on **current clock edge**

State Table

Present State	Next State		Output	
	x=0	x=1	x=0	x=1
0 0	00	10	0	0
0 1	10	10	0	0
1 0	00	11	0	0
1 1	10	11	0	1

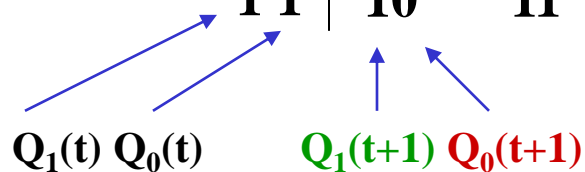

$$y(t) = x(t)Q_1(t)Q_0(t)$$

$$Q_0(t+1) = D_0(t) = x(t)Q_1(t)$$

$$Q_1(t+1) = D_1(t) = x(t) + Q_0(t)$$

State Table – 2 forms

Present State	Next State		Output	
	$x = 0$	$x = 1$	$x = 0$	$x = 1$
$Q_1(t)/ Q_0(t)$	$Q_1(t+1)/Q_0(t+1)$	$Q_1(t+1)/ Q_0(t+1)$	y	y
00	00	10	0	0
01	10	10	0	0
10	00	11	0	0
11	10	11	0	1

Present State		Input	Next State		Output
$Q_1(t)$	$Q_0(t)$	x	$Q_1(t+1)$	$Q_0(t+1)$	y
0	0	0	0	0	0
0	0	1	1	0	0
0	1	0	1	0	0
0	1	1	1	0	0
1	0	0	0	0	0
1	0	1	1	1	0
1	1	0	1	0	0
1	1	1	1	1	1

State Table

- All possible input combinations are listed
- All possible state combinations are listed
- Separate columns for each output value.
- Easier to use a symbol for each state.

Let:	Present State	Next State		Output	
		x=0	x=1	x=0	x=1
$s_0 = 00$	s_0	s_0	s_2	0	0
$s_1 = 01$	s_1	s_2	s_2	0	0
$s_2 = 10$	s_2	s_0	s_3	0	0
$s_3 = 11$	s_3	s_2	s_3	0	1

State Diagram

- **Circles** indicate current state
- Arrows point to **next state**
- For **x/y**, **x** is input and **y** is output

Present State	Next State		Output	
	x=0	x=1	x=0	x=1
00	00	10	0	0
01	10	10	0	0
10	00	11	0	0
11	10	11	0	1

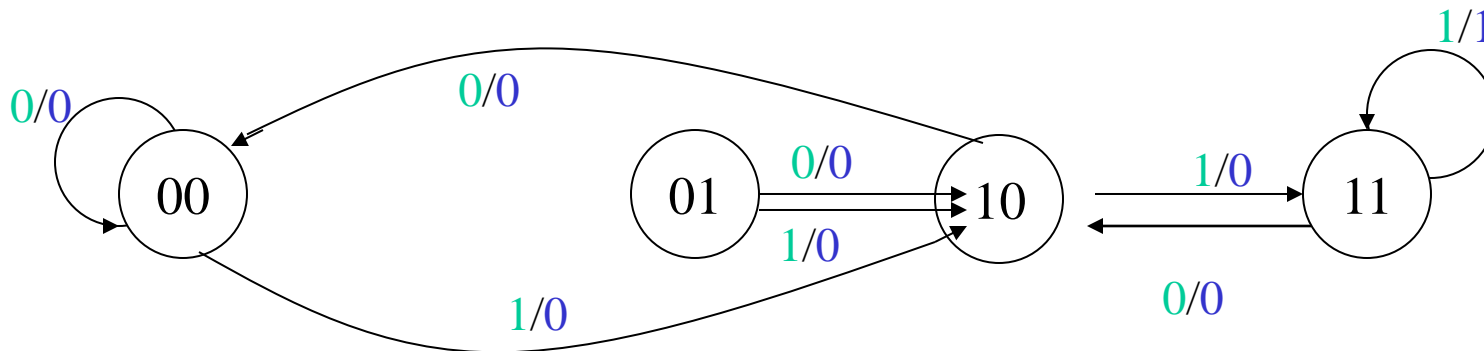

State Diagram

- Each state has two arrows leaving
 - One for $x = 0$ and one for $x = 1$
- Unlimited arrows can enter a state
- Use of state names in this example
 - Easier to identify

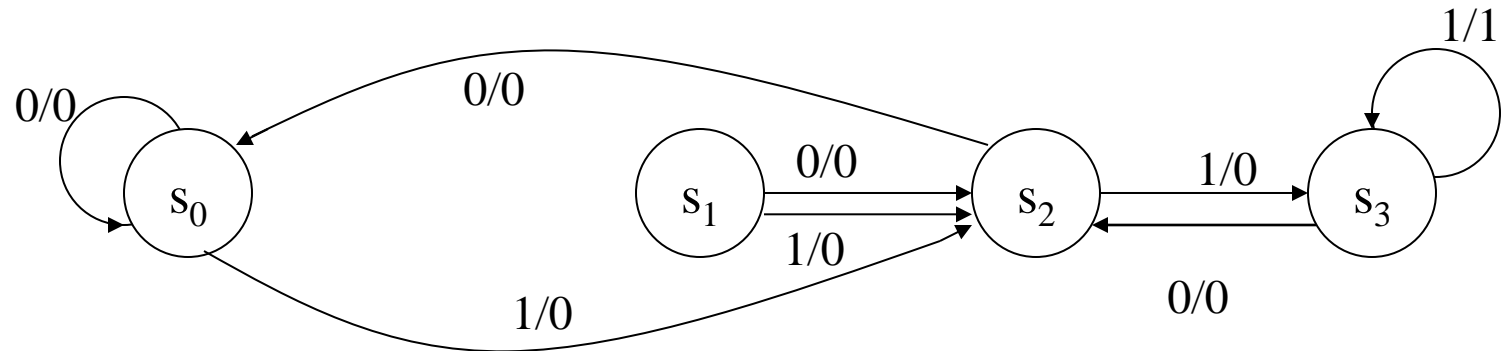

Analysis of synchronous sequential circuits

→ Analysis describes what a given circuit will do under certain conditions

→ Behavior of synchronous sequential circuit can be determined from

- Its inputs, its outputs and its Flip Flop state

→ Analysis Steps

- Circuit Diagram → Equations → State Table → State Diagram

- Identify Equations:

➤ F-F input eqn: $F\text{-F inputs} = F1(\text{inputs, present state})$

➤ Output eqn: $\text{Outputs} = F2(\text{inputs, present state})$

➤ State eqn: $\text{Next state} = F3(\text{inputs, present state})$

Example: Zero Detector

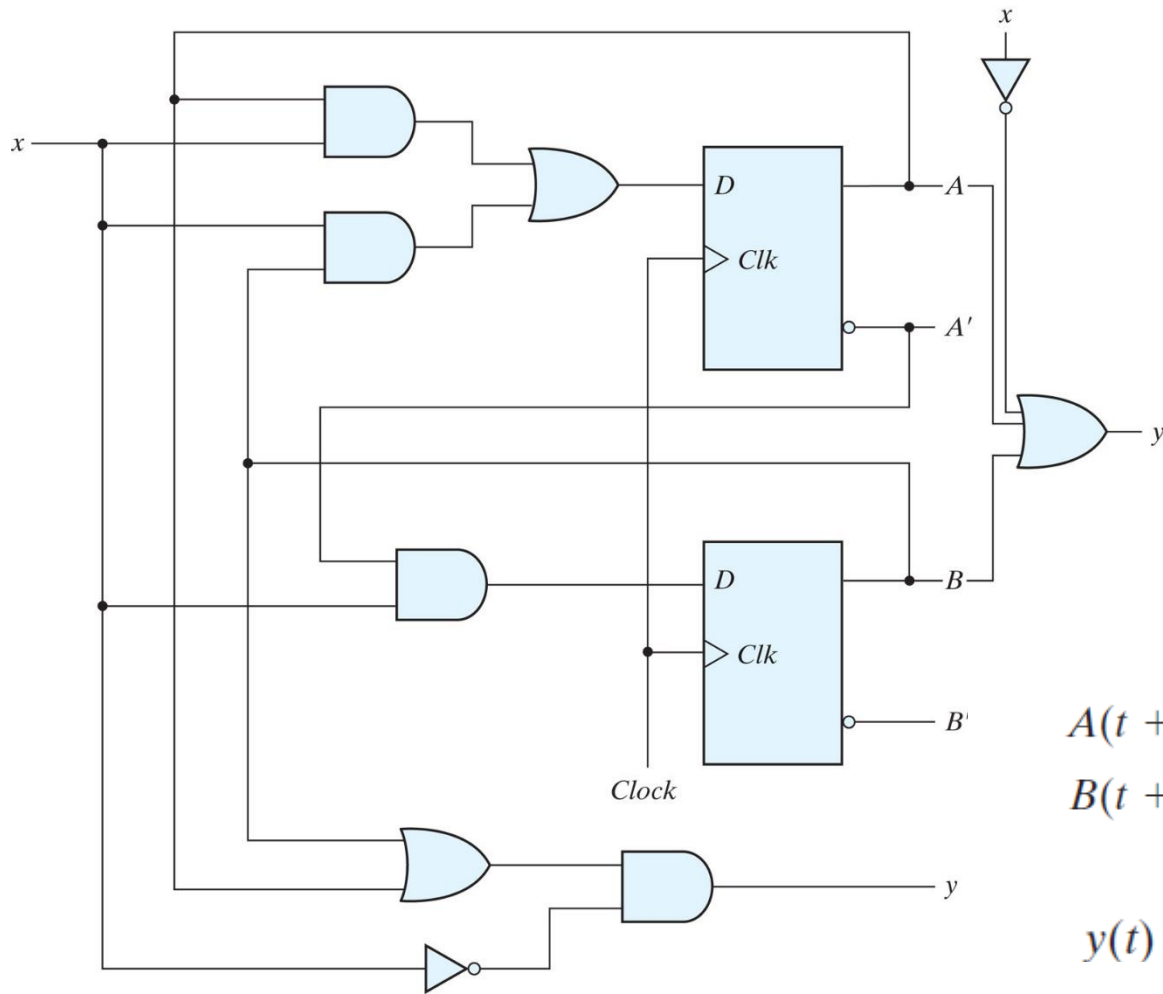

Copyright ©2013 Pearson Education, publishing as Prentice Hall

$$A(t + 1) = A(t)x(t) + B(t)x(t)$$

$$B(t + 1) = A'(t)x(t)$$

$$y(t) = [A(t) + B(t)]x'(t)$$

$$y = (A + B)x'$$

Zero Detector: State Table

Table 5.2
State Table for the Circuit of Fig. 5.15

Present State		Input	Next State		Output
A	B	x	A	B	y
0	0	0	0	0	0
0	0	1	0	1	0
0	1	0	0	0	1
0	1	1	1	1	0
1	0	0	0	0	1
1	0	1	1	0	0
1	1	0	0	0	1
1	1	1	1	0	0

Copyright ©2012 Pearson Education, publishing as Prentice Hall

Zero Detector: Second Form of the State Table

Table 5.3
Second Form of the State Table

Present State		Next State				Output	
		$x = 0$		$x = 1$		$x = 0$	$x = 1$
<i>A</i>	<i>B</i>	<i>A</i>	<i>B</i>	<i>A</i>	<i>B</i>	<i>y</i>	<i>y</i>
0	0	0	0	0	1	0	0
0	1	0	0	1	1	1	0
1	0	0	0	1	0	1	0
1	1	0	0	1	0	1	0

Zero Detector: State Diagram

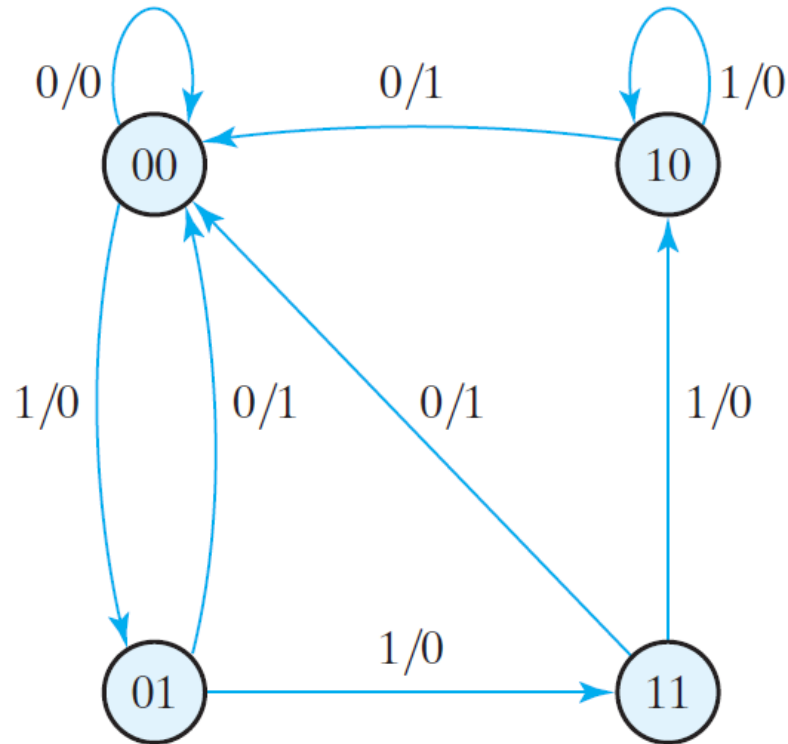
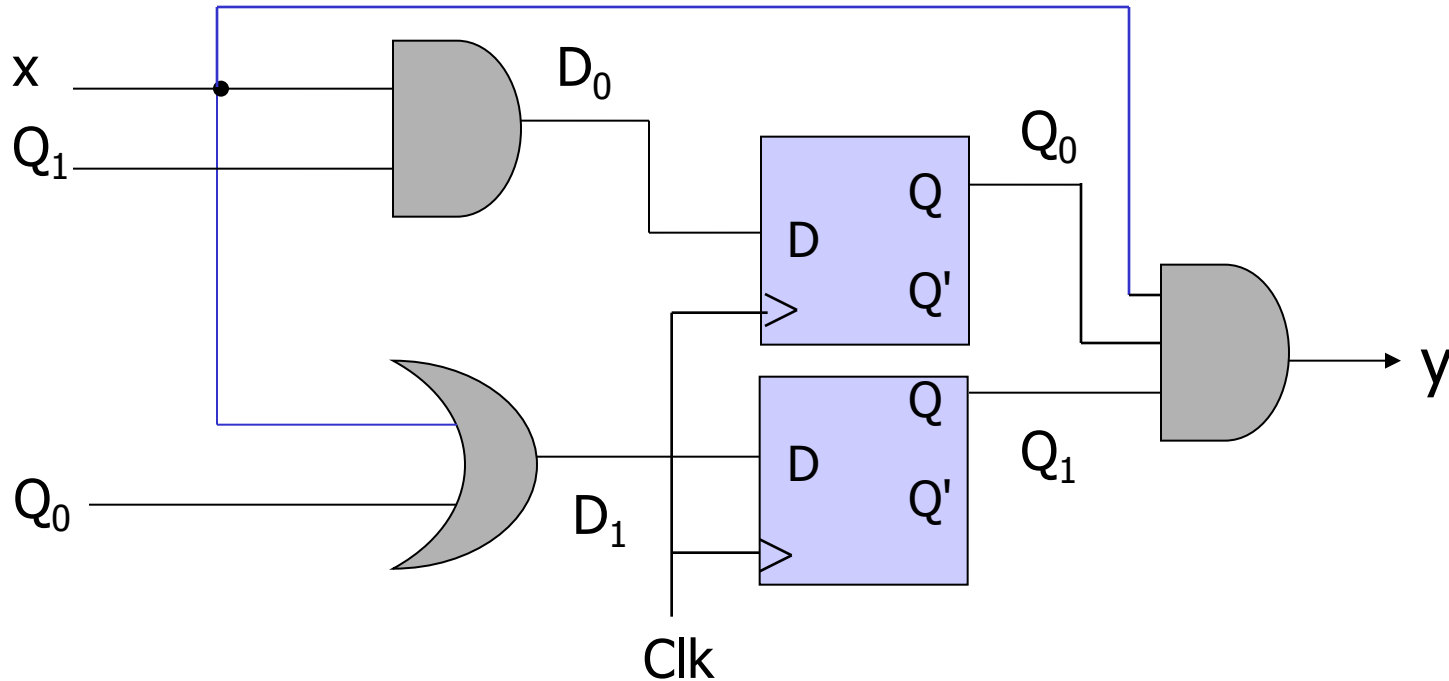

FIGURE 5.16

State diagram of the circuit of Fig. 5.15

Flip Flop Input Equations

- Boolean expressions which indicate the input to the flip flops.



$$D_{Q_0} = xQ_1$$
$$D_{Q_1} = x + Q_0$$

Analysis with D Flip-Flops

- Identify flip flop input equations $D_A = A \oplus x \oplus y$
- Identify output equation (no output in this example)
- Identify state equation $A(t+1) = D_A = A \oplus x \oplus y$

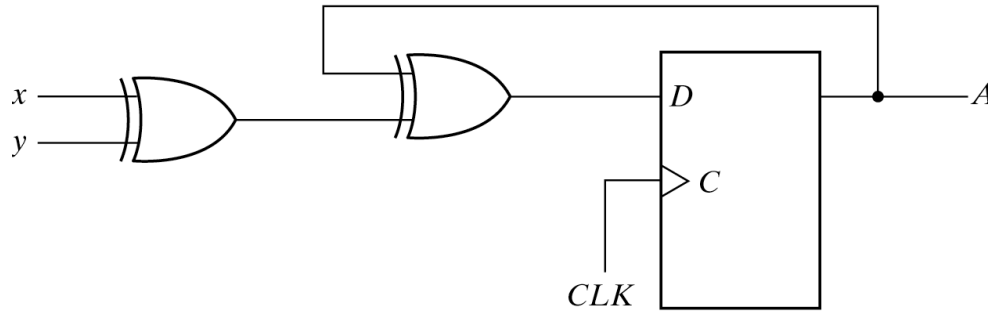

(a) Circuit diagram

Present state	Inputs		Next state
A	x	y	A
0	0	0	0
0	0	1	1
0	1	0	1
0	1	1	0
1	0	0	1
1	0	1	0
1	1	0	0
1	1	1	1

(b) State table

Note: this example has no output

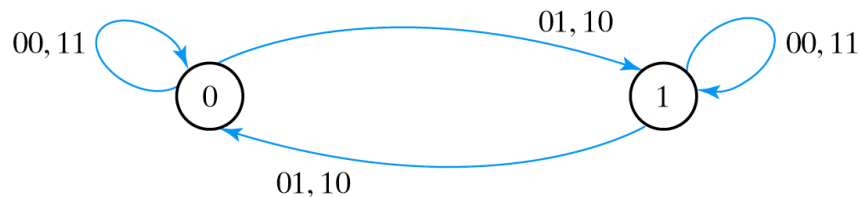

(c) State diagram

Example: JK Flip-Flops

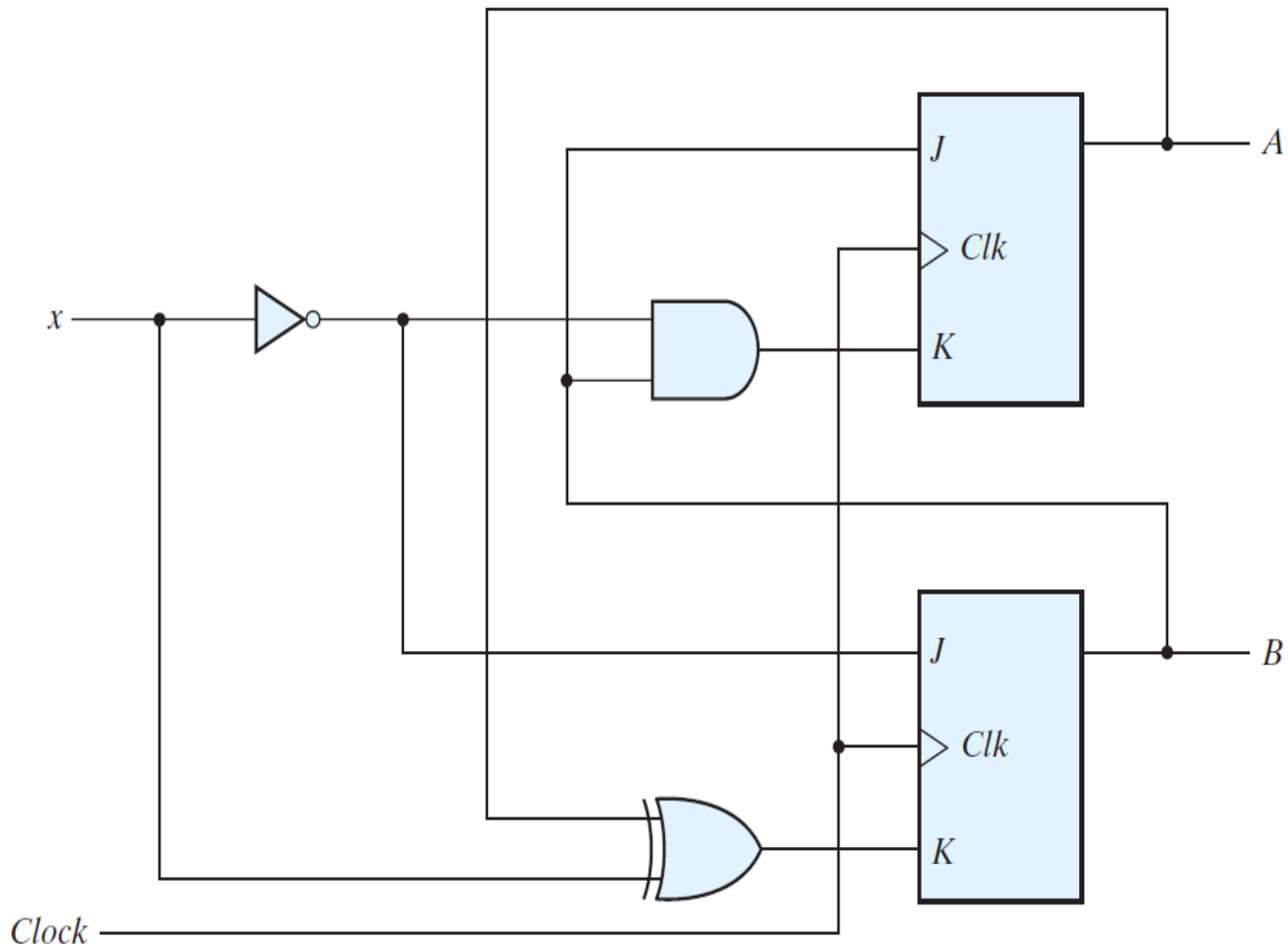

FIGURE 5.18
Sequential circuit with JK flip-flop

Example: JK Flip-Flops

1. Determine the flip-flop input equations in terms of the present state and input variables.
2. List the binary values of each input equation.
3. Use the corresponding flip-flop characteristic table to determine the next-state values in the state table.

The next-state values can also be obtained by evaluating the state equations from the characteristic equation. This is done by using the following procedure:

1. Determine the flip-flop input equations in terms of the present state and input variables.
2. Substitute the input equations into the flip-flop characteristic equation to obtain the state equations.
3. Use the corresponding state equations to determine the next-state values in the state table.

$$J_A = B \quad K_A = Bx'$$

$$J_B = x' \quad K_B = A'x + Ax' = A \oplus x$$

$$A(t + 1) = J_A A' + K'_A A$$
$$B(t + 1) = J_B A' + K'_B B$$



$$A(t + 1) = BA' + (Bx')' A = A'B + AB' + Ax$$

$$B(t + 1) = x'B' + (A \oplus x)' B = B'x' + ABx + A'Bx'$$

Example: JK Flip-Flops

Table 5.4
State Table for Sequential Circuit with JK Flip-Flops

Present State		Input	Next State		Flip-Flop Inputs			
A	B		A	B	J_A	K_A	J_B	K_B
0	0	0	0	1	0	0	1	0
0	0	1	0	0	0	0	0	1
0	1	0	1	1	1	1	1	0
0	1	1	1	0	1	0	0	1
1	0	0	1	1	0	0	1	1
1	0	1	1	0	0	0	0	0
1	1	0	0	0	1	1	1	1
1	1	1	1	1	1	0	0	0

Copyright ©2012 Pearson Education, publishing as Prentice Hall

Example: JK Flip-Flops

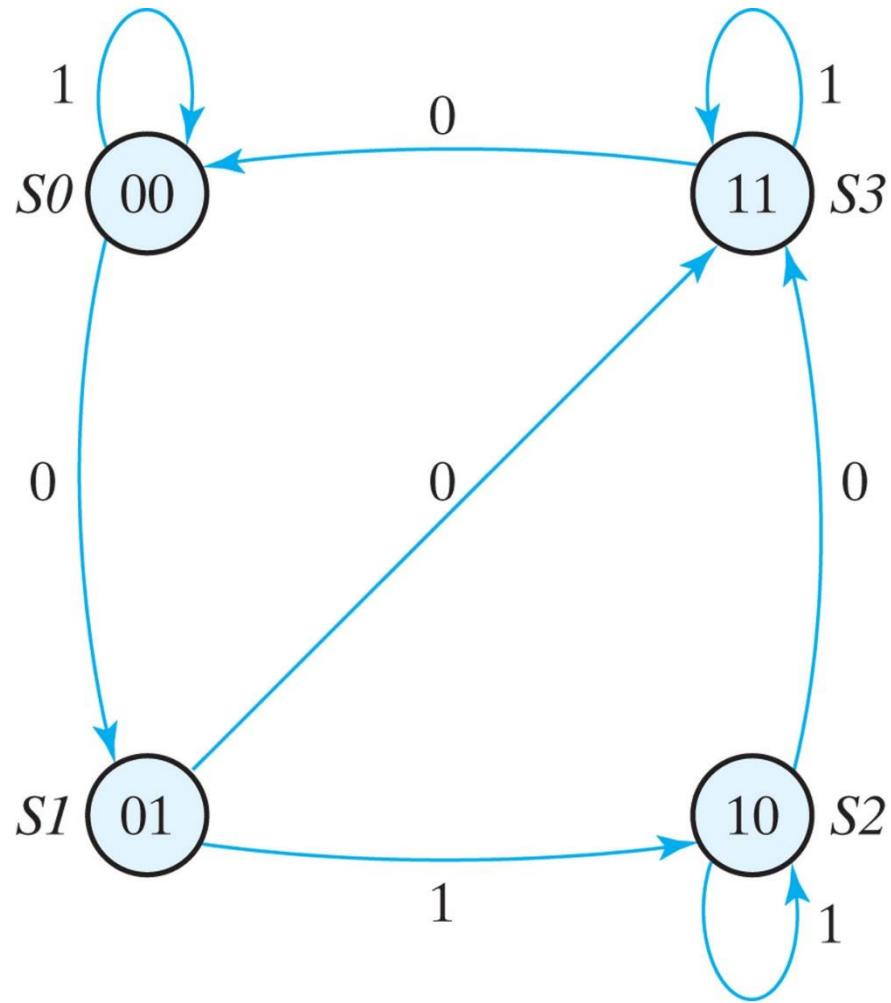

Copyright ©2013 Pearson Education, publishing as Prentice Hall

Example: T Flip-Flops

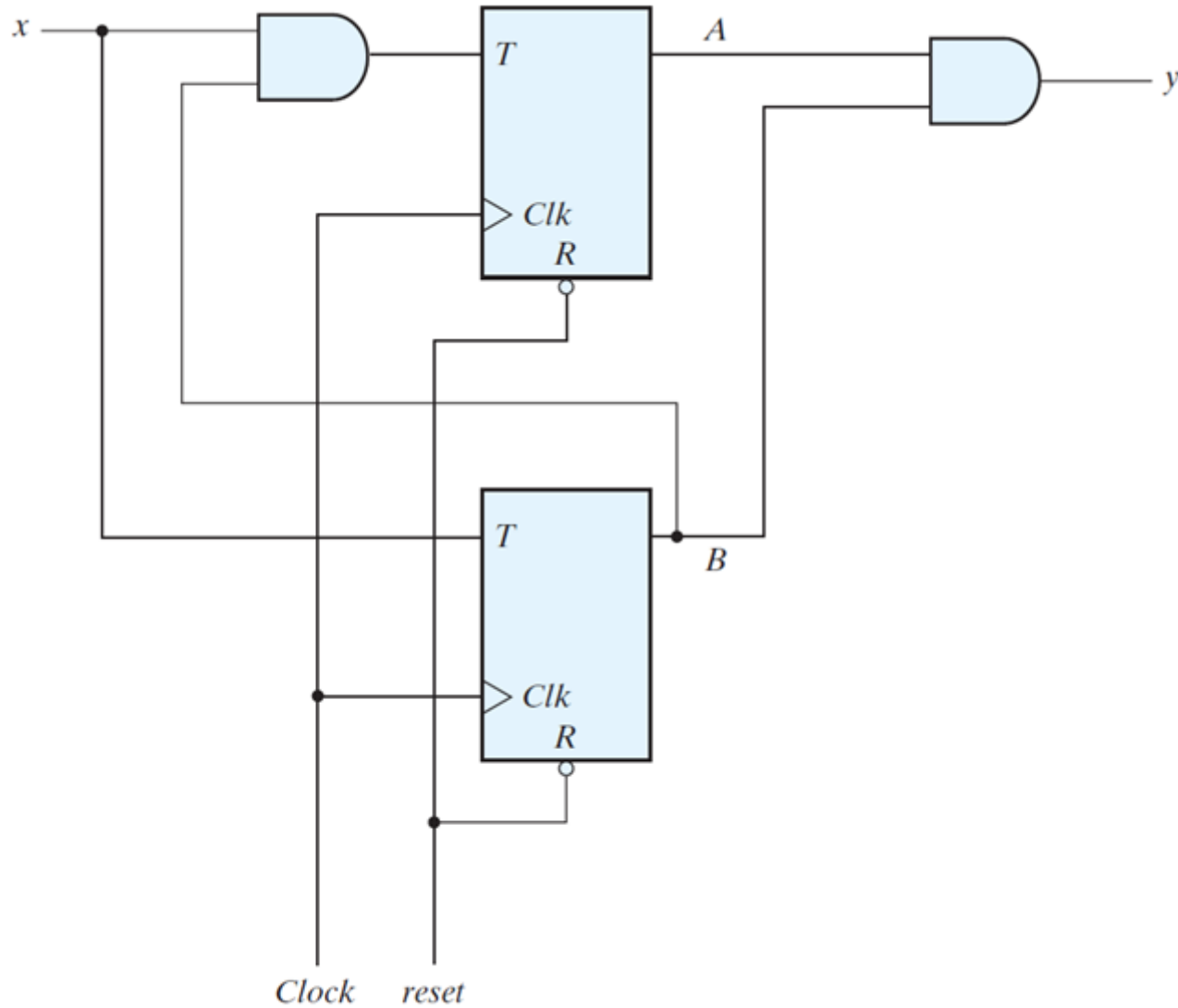

(a) Circuit diagram

Mealy and Moore Models

- A general model of a Sequential Circuit has
 - Inputs
 - Outputs
 - Internal States
- Circuits with different states known as Finite State Machines (FSMs)
- There are two “standard models”
 - Mealy Model, known as Mealy Finite State Machine (or Mealy machine)
 - Moore Model known as Moore Finite State Machine (or Moore Machine)

Mealy Machine

- Output based on state and present input

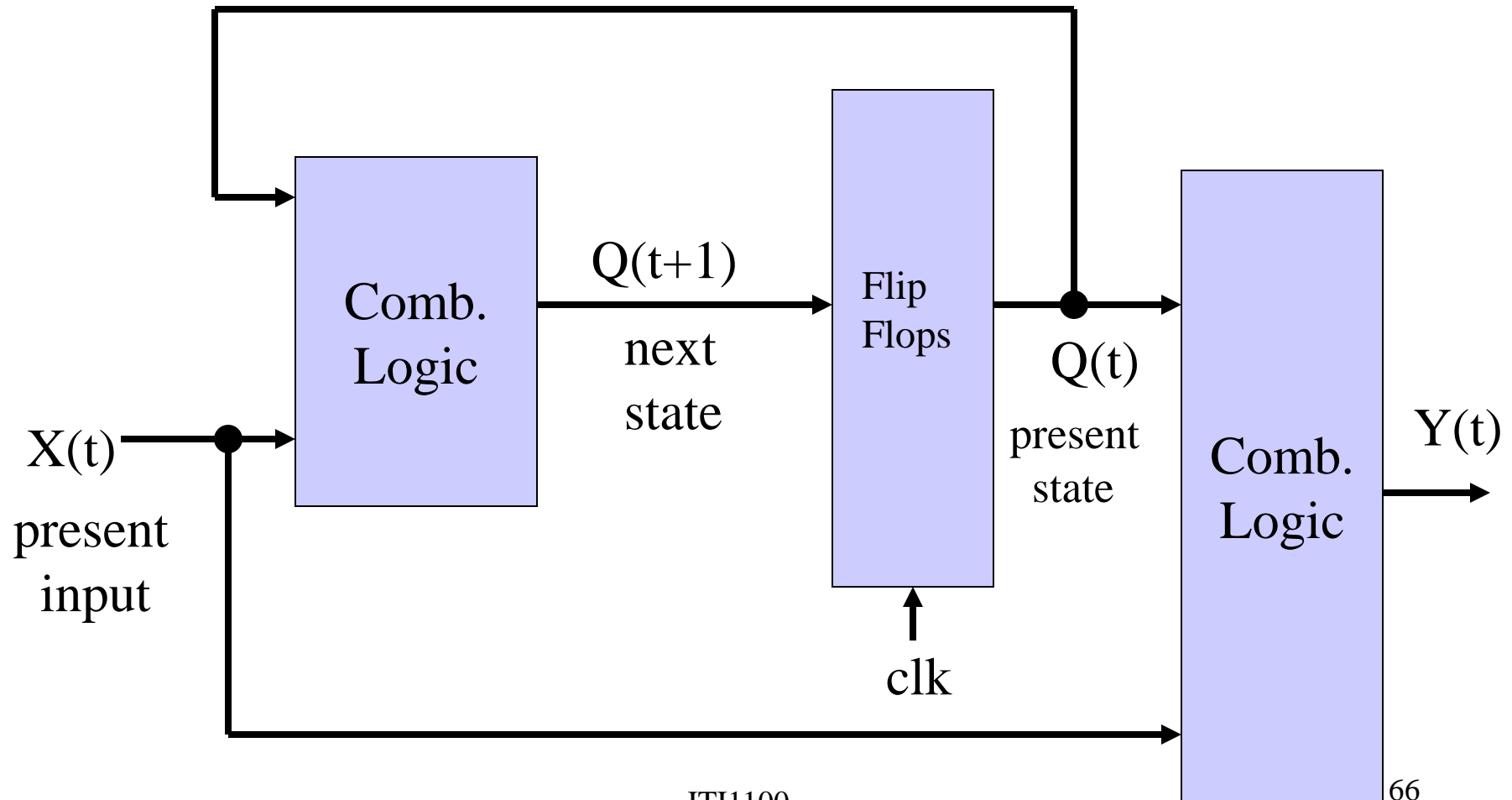

Example of Mealy Machine

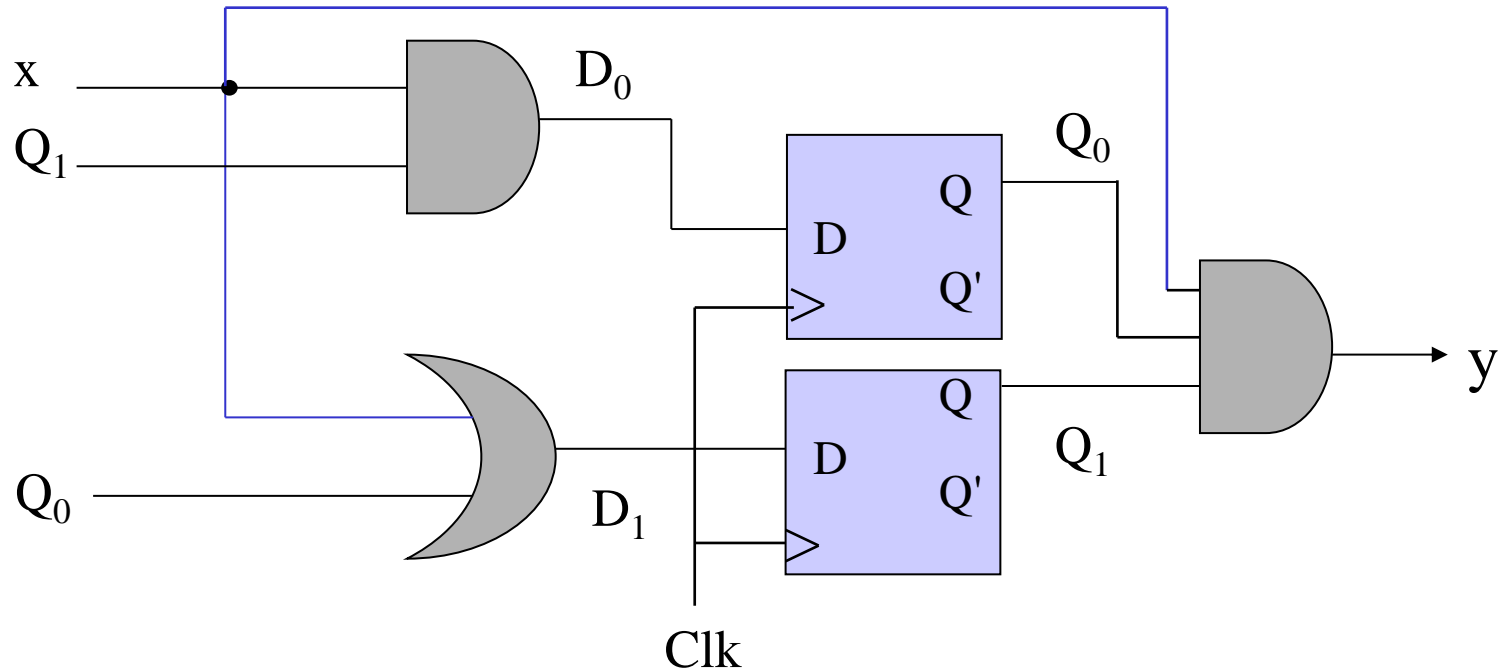

Moore Machine

- Output based on state only

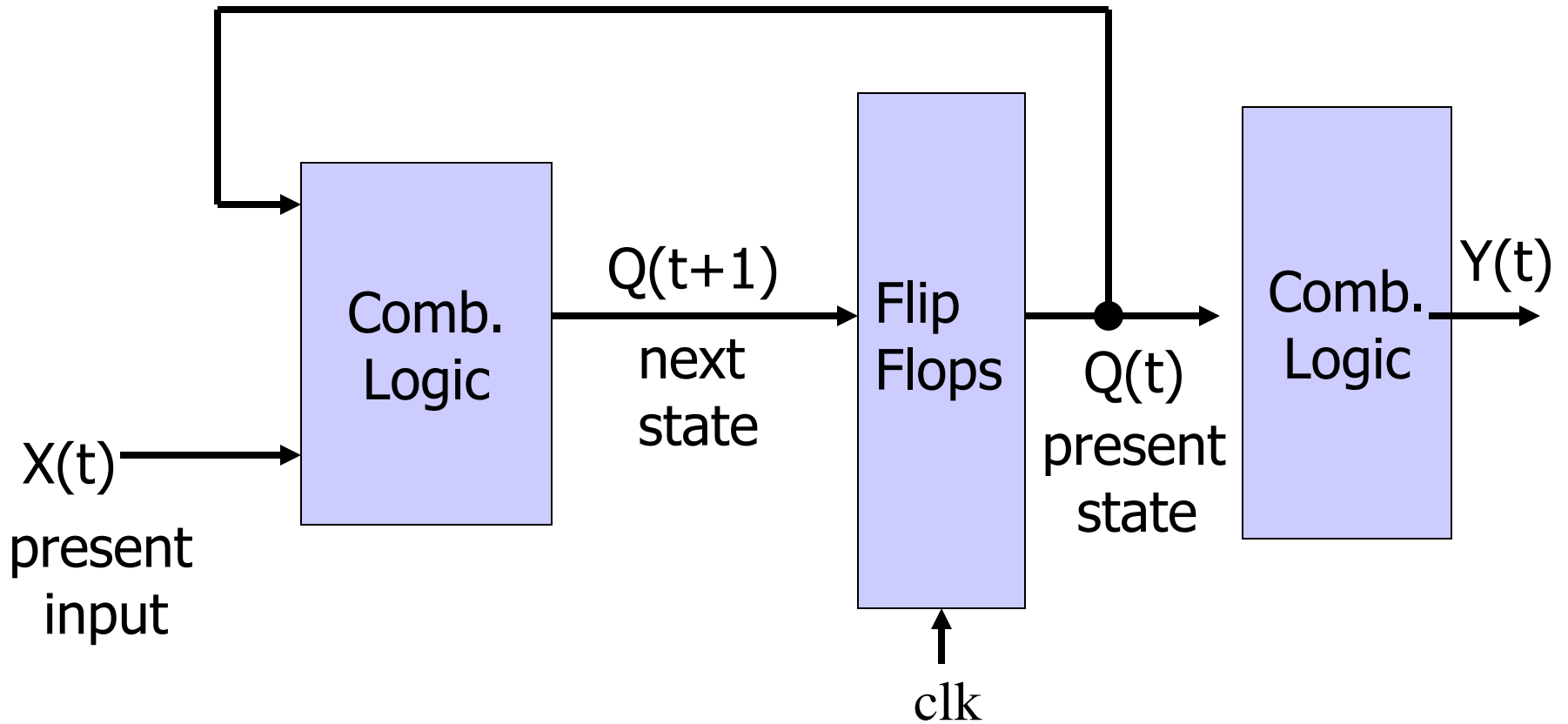

Example of Moore Machine

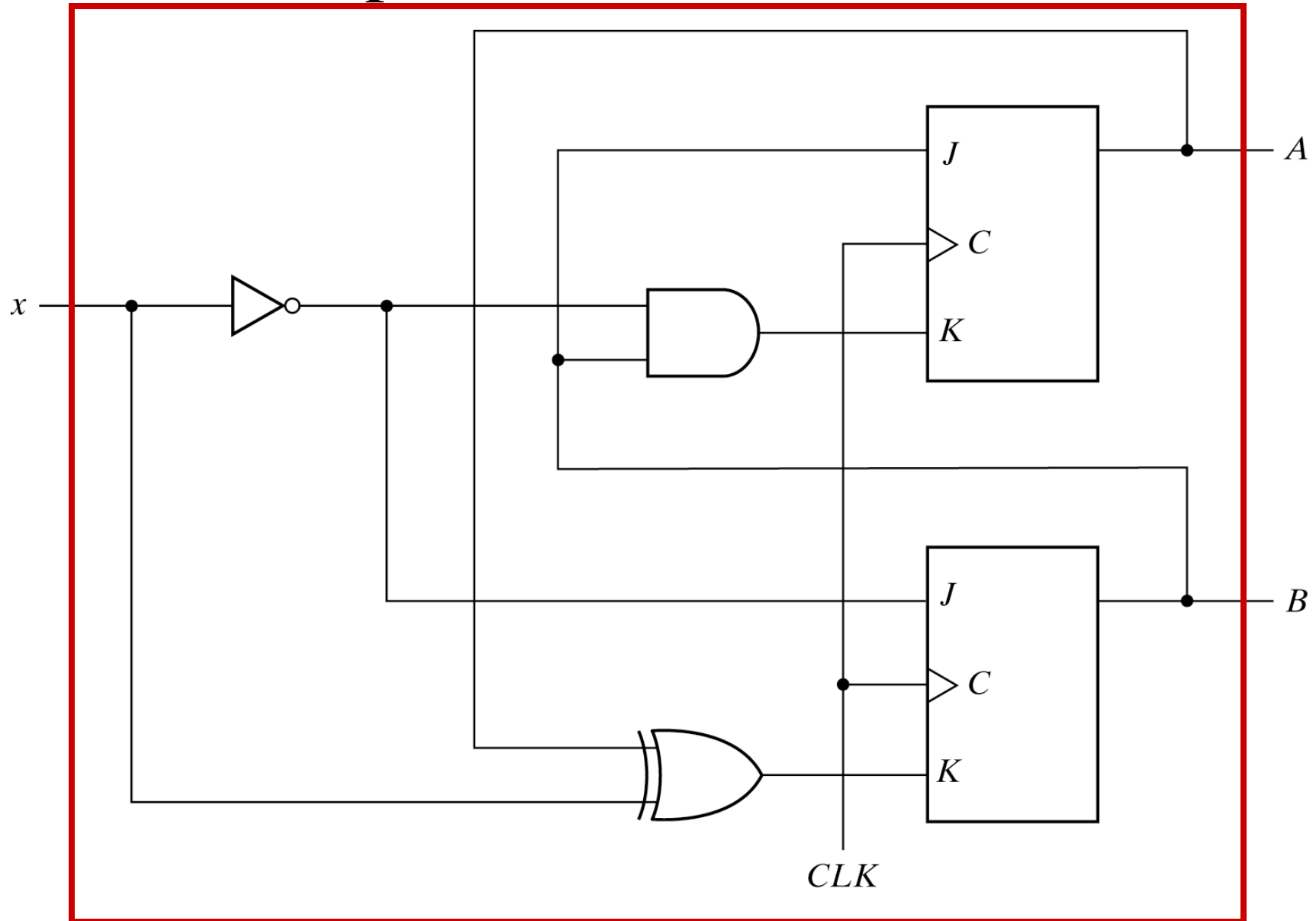

Fig. 5-18 Sequential Circuit with JK Flip-Flop

Example 1 D FF Analysis

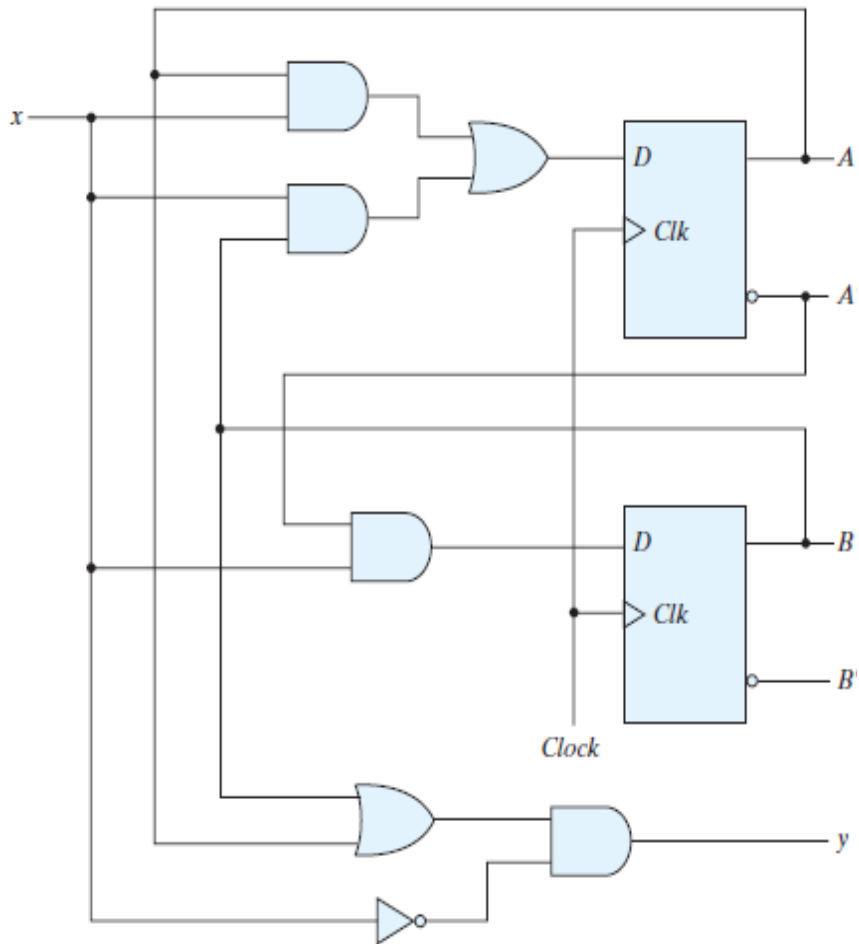
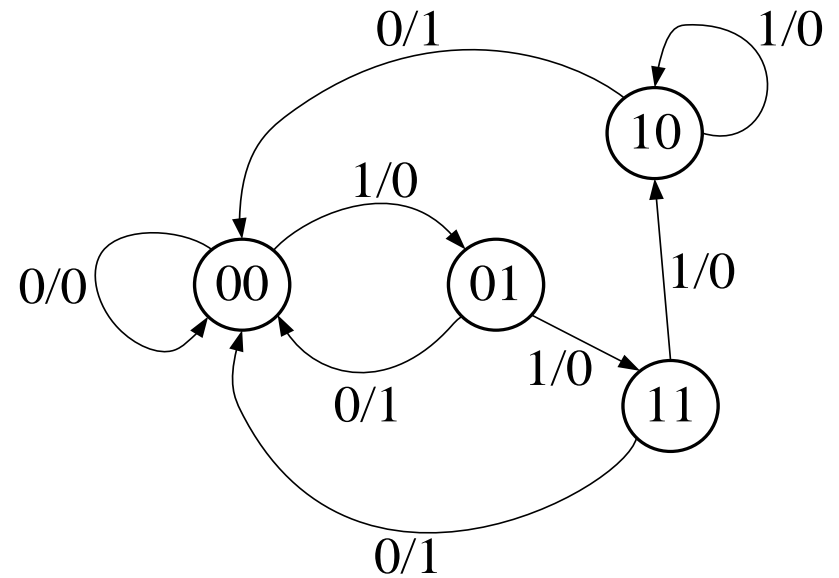

FIGURE 5.15
Example of sequential circuit

Zero Detector



Mealy FSM
(Outputs indicated on transition arrows)

Example 2 JK FF Analysis

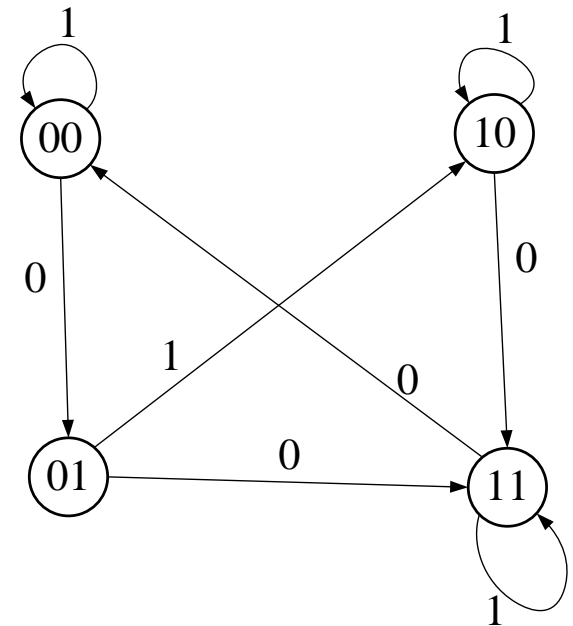
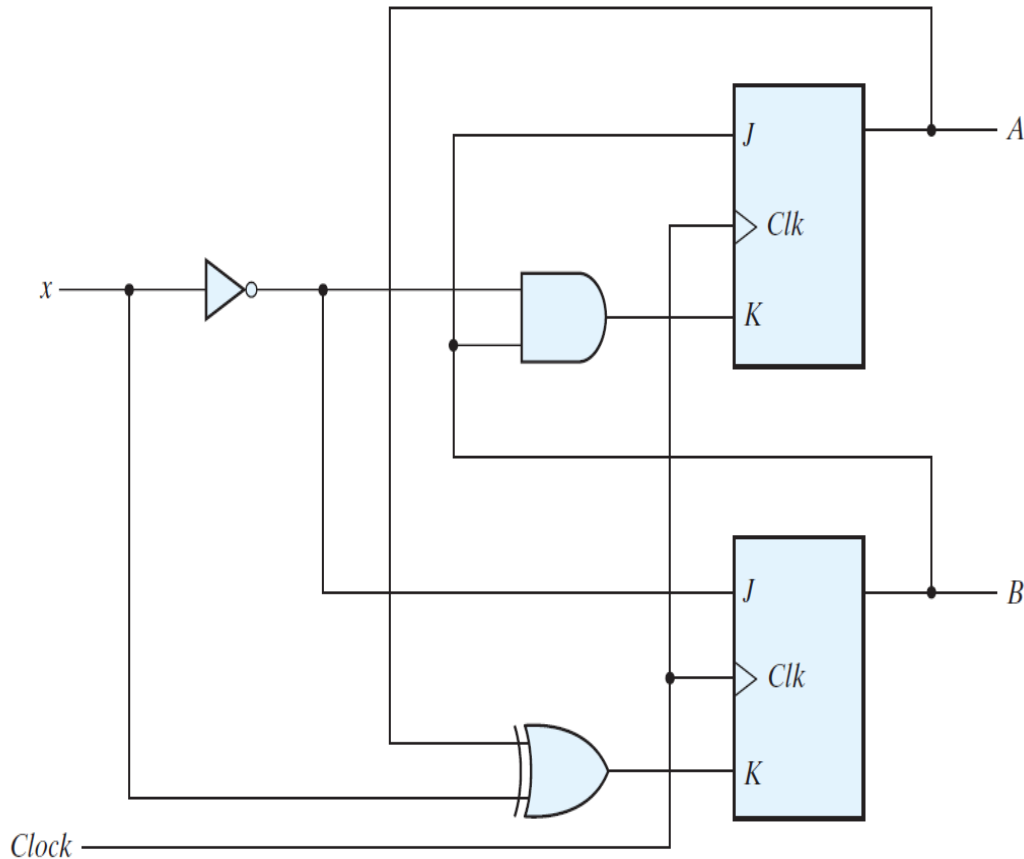
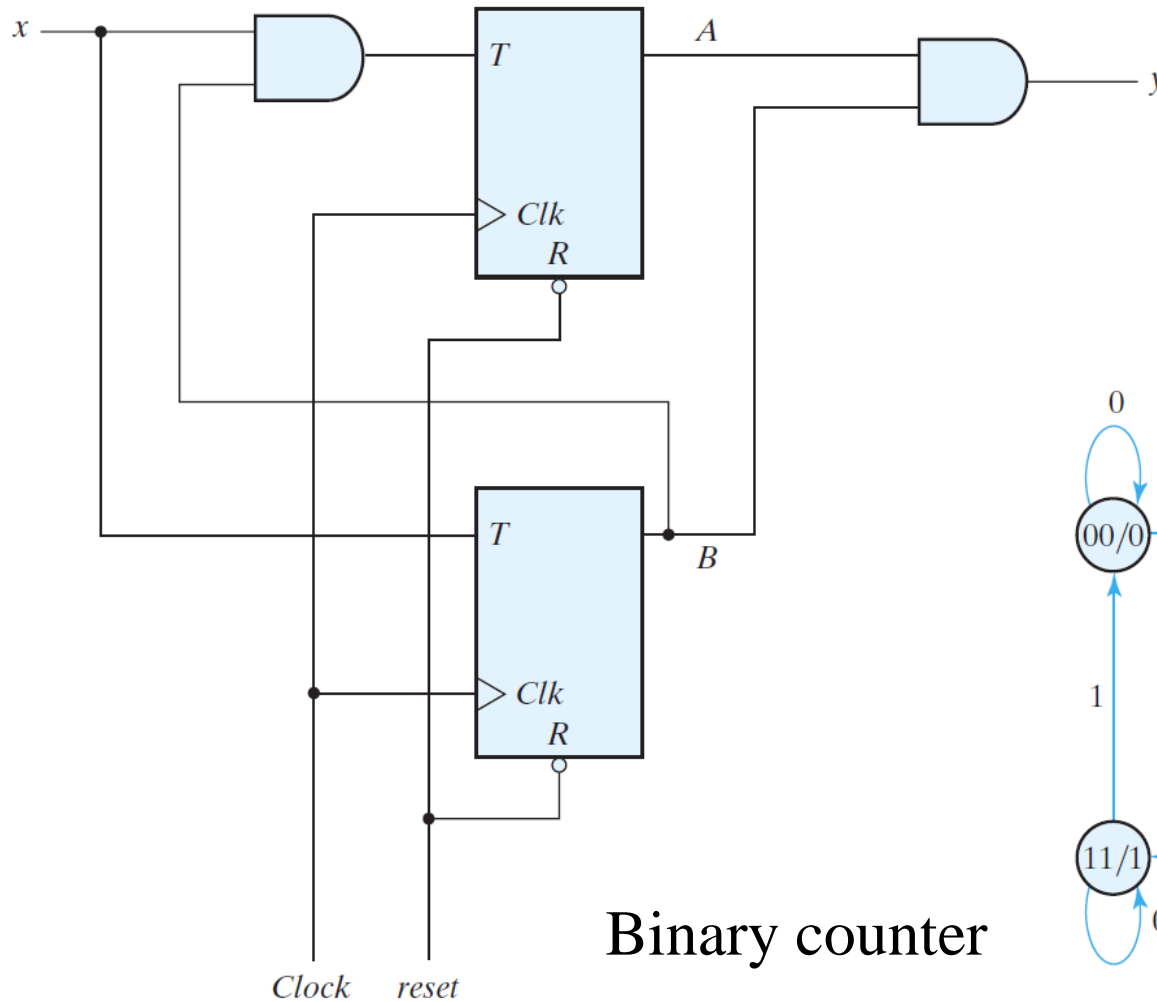

FIGURE 5.18
Sequential circuit with JK flip-flop

Moore FSM
(Outputs reflected by
FF states)

Example 3 T FF Analysis



(a) Circuit diagram

Binary counter

Moore FSM
(Outputs reflected by
FF states, within state
bubbles)

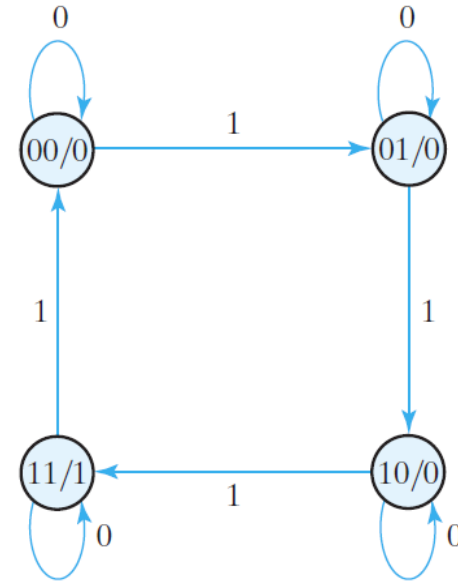

(b) State diagram

Design of Sequential Circuits

- So far, we have examined the analysis of sequential circuits
 - Circuit Diagram → Equations → State Table → State diagram
- Now we want to design sequential circuits
 - State Diagram → State Reduction → State Assignment → State Table → Select type of FF's → Derive: FF input Equations, State equations; Output equations (minimized) → Circuit Diagram
 - Note: FF Input Equations/Output Equations lead to combinational circuit design.

State Reduction (1)

- Consider a the following state diagram

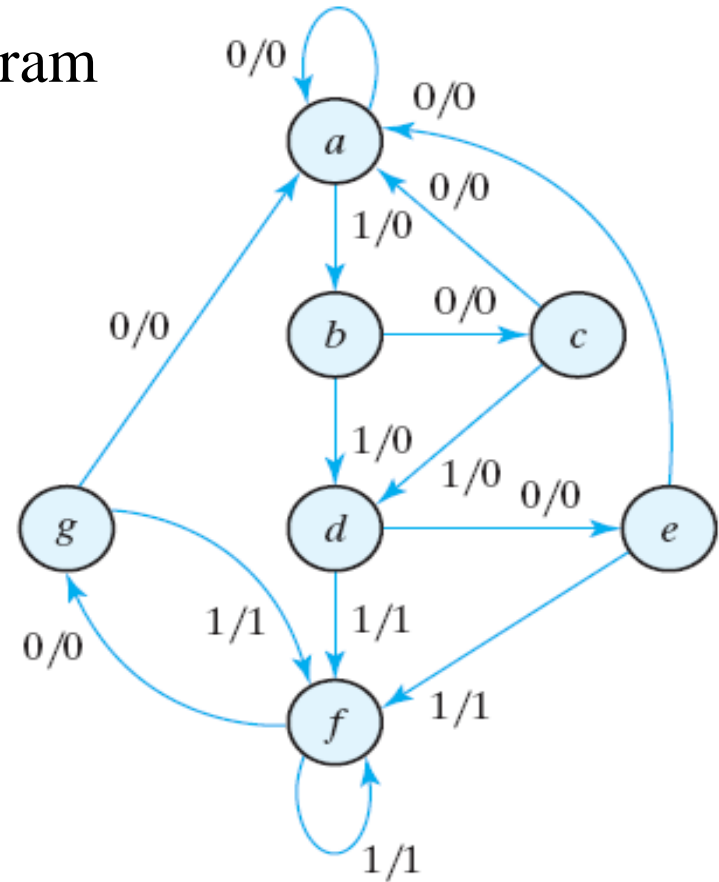

- The following is the output sequence generated by the FSM for the given input sequence:

state	<i>a</i>	<i>a</i>	<i>b</i>	<i>c</i>	<i>d</i>	<i>e</i>	<i>f</i>	<i>f</i>	<i>g</i>	<i>f</i>	<i>g</i>	<i>a</i>
input	0	1	0	1	0	1	1	0	1	0	0	
output	0	0	0	0	0	1	1	0	1	0	0	

State Reduction (2)

- Possible that an FSM with fewer states can generate same input/output sequences
 - Nice to have method to reduce # of states in FSM
- An approach:
 - Generate a state table from the given state diagram
 - Apply the following algorithm:
 - 2 states are equivalent if
 - They give the same output for each member of the set of inputs
 - They send the circuit to the same or to an equivalent state
 - When 2 states are equivalent, one can be removed without altering the input/output relationship:
 - Remove the row(s) in the state table where present state equals the removed state
 - Where ever the removed state occurs in the Next state column(s), it is replaced by its equivalent state.

State Reduction (3)

- Obtaining the State table from State diagram of the previous slide

State **e** and **g** are equivalent \rightarrow have the same next states and same output when $x=0$, $x=1$

State Table

Present State	Next State		Output	
	$x = 0$	$x = 1$	$x = 0$	$x = 1$
<i>a</i>	<i>a</i>	<i>b</i>	0	0
<i>b</i>	<i>c</i>	<i>d</i>	0	0
<i>c</i>	<i>a</i>	<i>d</i>	0	0
<i>d</i>	<i>e</i>	<i>f</i>	0	1
\rightarrow <i>e</i>	<i>a</i>	<i>f</i>	0	1
<i>f</i>	<i>g</i>	<i>f</i>	0	1
\rightarrow <i>g</i>	<i>a</i>	<i>f</i>	0	1

Reducing the State Table

Present State	Next State		Output	
	$x = 0$	$x = 1$	$x = 0$	$x = 1$
<i>a</i>	<i>a</i>	<i>b</i>	0	0
<i>b</i>	<i>c</i>	<i>d</i>	0	0
<i>c</i>	<i>a</i>	<i>d</i>	0	0
<i>d</i>	<i>e</i>	<i>f</i>	0	1
<i>e</i>	<i>a</i>	<i>f</i>	0	1
<i>f</i>	<i>e</i>	<i>f</i>	0	1

\swarrow Remove row with present state **g** and replace it by **e** in remaining next states

State Reduction (4)

Reducing the State Table

Present State	Next State		Output	
	$x = 0$	$x = 1$	$x = 0$	$x = 1$
<i>a</i>	<i>a</i>	<i>b</i>	0	0
<i>b</i>	<i>c</i>	<i>d</i>	0	0
<i>c</i>	<i>a</i>	<i>d</i>	0	0
→ <i>d</i>	<i>e</i>	<i>f</i>	0	1
<i>e</i>	<i>a</i>	<i>f</i>	0	1
→ <i>f</i>	<i>e</i>	<i>f</i>	0	1

Reduced State Table

Present State	Next State		Output	
	$x = 0$	$x = 1$	$x = 0$	$x = 1$
<i>a</i>	<i>a</i>	<i>b</i>	0	0
<i>b</i>	<i>c</i>	<i>d</i>	0	0
<i>c</i>	<i>a</i>	<i>d</i>	0	0
<i>d</i>	<i>e</i>	<i>d</i>	0	1
<i>e</i>	<i>a</i>	<i>d</i>	0	1

f and *d* are equivalent

State Reduction (4)

- New state machine contains only 5 states and produces same input/output sequences
 - May result in less equipment, but May not lead to savings in Flip-flops
 - In practice, state reduction may be skipped.

Reduced State Table

Present State	Next State		Output	
	$x = 0$	$x = 1$	$x = 0$	$x = 1$
a	a	b	0	0
b	c	d	0	0
c	a	d	0	0
d	e	d	0	1
e	a	d	0	1

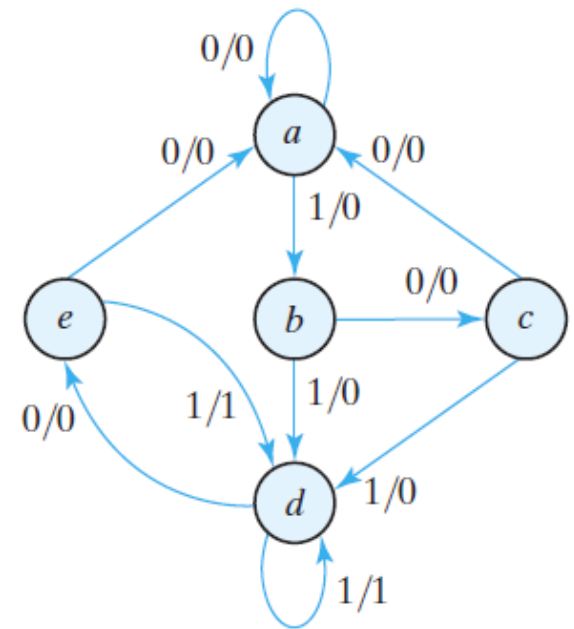

state	a	a	b	c	d	e	d	d	e	d	e	a
input	0	1	0	1	0	1	1	0	1	0	0	
output	0	0	0	0	0	1	1	0	1	0	0	

State Assignment (1)

- To assign coded binary values to the states: for circuit with m states, codes must contain n bits where $2^n \geq m$
 - E.g., with 7 states, require 3 bits, one state is unused
 - E.g., with 5 states, require 3 bits, three states are unused
- Unused states can be treated as don't care conditions
 - Can simplify combinational circuits
- Coding states
 - Use counting order: five states use 000 to 100 (101, 110, 111 are unused)
 - Use Gray code: Only one bit changes from one number to next
 - One-hot assignment: as many bits as states and only 1 bit set in the state number

State Assignment (2)

Table 5.9
Three Possible Binary State Assignments

State	Assignment 1, Binary	Assignment 2, Gray Code	Assignment 3, One-Hot
<i>a</i>	000	000	00001
<i>b</i>	001	001	00010
<i>c</i>	010	011	00100
<i>d</i>	011	010	01000
<i>e</i>	100	110	10000

- One-Hot
 - Usually leads to simpler decoding logic for next state and output
 - FSM can be faster than that with sequential binary encoding
 - Silicon area required for extra flip-flops can be offset by area saved in simpler decoding logic. No guarantee in this trade-off, must be evaluated for given design

Design Procedure

- Design of systems that input flip flops and combinational logic
- Specifications start with a **word** description
- Create a state table to indicate next states
- Convert next states and outputs to output and flip flop input equations
 - Reduce logic expressions using truth tables
- Draw resulting circuits.

Designing Finite State Machines

- **Specify the problem with words**
 - *(e.g. Design a circuit that detects three consecutive 1 inputs)*
- **Derive a state diagram**
- **Reduce the number of states if necessary**
- **Assign binary values to states**
- **Develop a state table**
- **Choose flip flop type**
- **Use K-maps to simplify expressions**
 - **Flip flop input equations and output equations**
- **Create appropriate logic diagram**
 - **Should include combinational logic and flip flops**

Example: Detect 3 or More Consecutive 1 Inputs

State Diagram

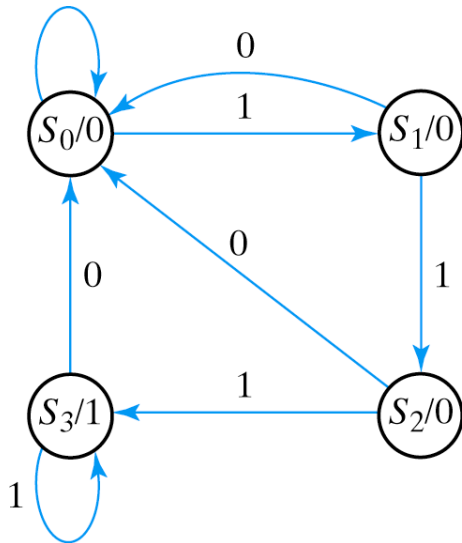

- **State S_0 : zero 1s detected**
- **State S_1 : one 1 detected**
- **State S_2 : two 1s detected**
- **State S_3 : three or more 1s detected**

Fig. 5-24 State Diagram for Sequence Detector

- **Moore circuit with output 0 at S_0 , S_1 , S_2 , and 1 at S_3 .**
- **Each state has 2 output arrows**
- **Two bits needed to encode state**

State Table for Sequence Detector

Present State		Input	Next State		Output
A	B		A	B	
0	0	0	0	0	0
0	0	1	0	1	0
0	1	0	0	0	0
0	1	1	1	0	0
1	0	0	0	0	0
1	0	1	1	1	0
1	1	0	0	0	1
1	1	1	1	1	1

- **Sequence of outputs, inputs, and flip flop states enumerated in state table**
- **Present state** indicates current value of flip flops
- **Next state** indicates state after next rising clock edge
- **Output** is output value on current clock edge

◦ $S_0 = 00$

◦ $S_1 = 01$

◦ $S_2 = 10$

◦ $S_3 = 11$

Design with D FF's

- Word to State Diagram (Done)
- Derive the State Table from State Diagram (Done)
- Choose type of Flip-Flop: D
 - Two D flip-flops to represent 4 states
 - Outputs of FF: A and B
- Develop the **FF Input equations** and **output equations**
- Derive Circuit Diagram

Finding FF Input Equation and Output Equation

- FF D input = “next state”, $Q(t + 1) = D_Q$
- From state table, find **FF input equation** of D_Q with regard to present state and inputs
- Find **output equation** of y with regard to present state and inputs

Present State		Input	Next State		Output	FF Inputs	
A	B	x	A	B	y	D_A	D_B
0	0	0	0	0	0	0	0
0	0	1	0	1	0	0	1
0	1	0	0	0	0	0	0
0	1	1	1	0	0	1	0
1	0	0	0	0	0	0	0
1	0	1	1	1	0	1	1
1	1	0	0	0	1	0	0
1	1	1	1	1	1	1	1

Finding FF Input Equation and Output Equation

- Create K-map directly from state table (3 K-maps for D_A , D_B , and y)
- Minimize K-maps to find SOP representations

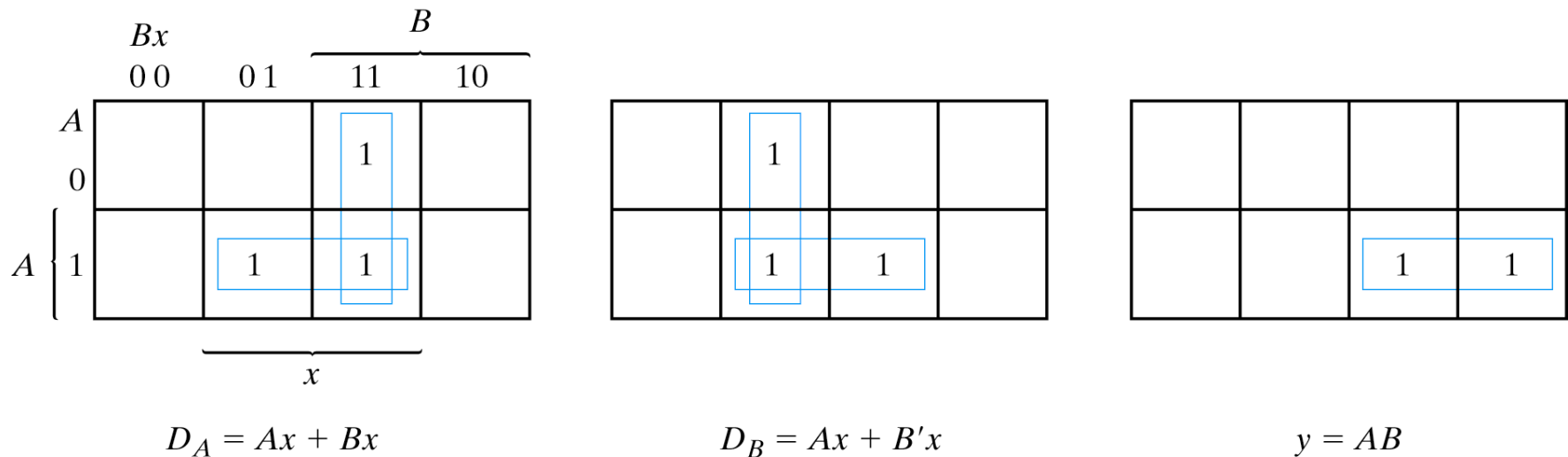

Fig. 5-25 Maps for Sequence Detector

Circuit Diagram – Sequence Decoder

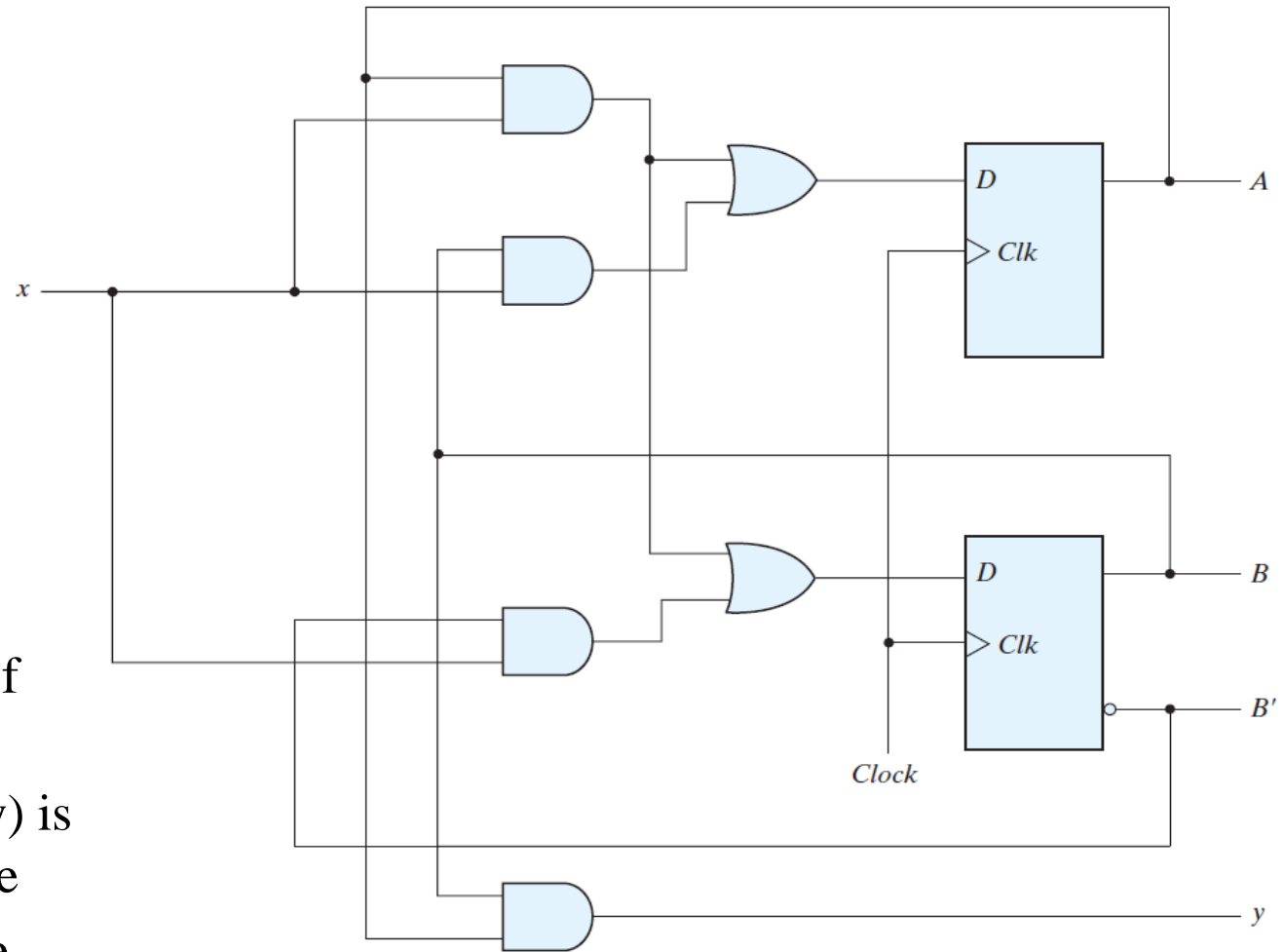

FIGURE 5.29
Logic diagram of a Moore-type sequence detector

- Note location of state flip flops
- Output value (y) is function of state
- This is a Moore machine.

Excitation Tables (JK and T FF's)

- Input FF equations derived indirectly from state table
 - For D FF, input equations obtained directly from next state
 - Not so for JK and T FF's – need excitation tables.
- Excitation table: list required inputs for a given state change.

JK Flip Flop

J	K	Q(t+1)	Comment
0	0	Q(t)	No Change
0	1	0	Reset
1	0	1	Set
1	1	Q'(t)	Complement

Characteristic
Tables

T Flip Flop

T	Q(t+1)	Comment
0	Q(t)	No change
1	Q'(t)	Complement (toggle)

Excitation
Tables

Q(t)	Q(t+1)	J	K
0	0	0	X
0	1	1	X
1	0	X	1
1	1	X	0

Q(t)	Q(t+1)	T
0	0	0
0	1	1
1	0	1
1	1	0

Design with JK FF's

- Design the circuit for the following state diagram
 - State table, FF Input equations, Circuit

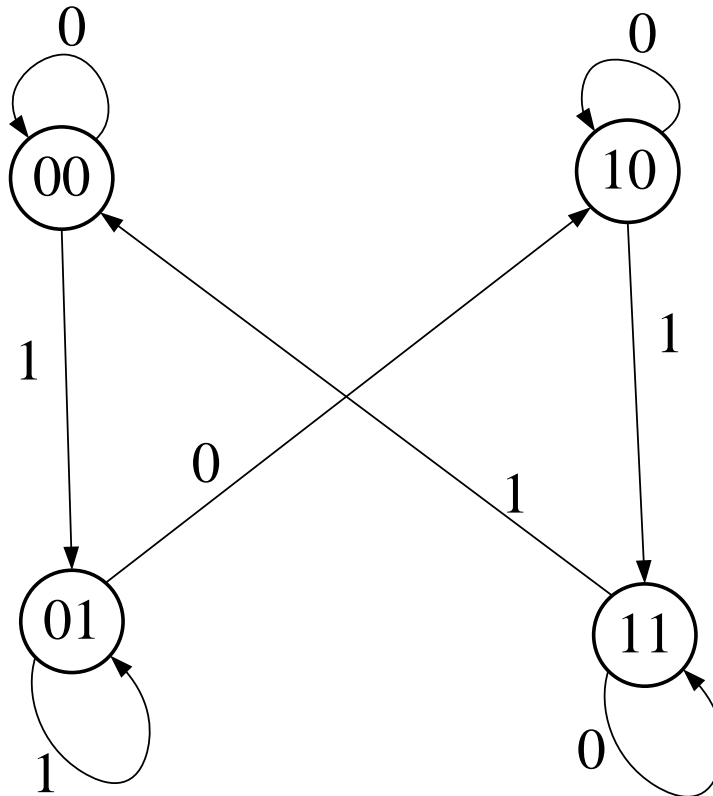

Design with JK FF's – State Table

Add FF inputs in the state table to get FF input equations

Table 5.13

State Table and JK Flip-Flop Inputs

Present State		Input	Next State		Flip-Flop Inputs			
<i>A</i>	<i>B</i>		<i>A</i>	<i>B</i>	<i>J_A</i>	<i>K_A</i>	<i>J_B</i>	<i>K_B</i>
0	0	0	0	0	0	X	0	X
0	0	1	0	1	0	X	1	X
0	1	0	1	0	1	X	X	1
0	1	1	0	1	0	X	X	0
1	0	0	1	0	X	0	0	X
1	0	1	1	1	X	0	1	X
1	1	0	1	1	X	0	X	0
1	1	1	0	0	X	1	X	1

Copyright ©2012 Pearson Education, publishing as Prentice Hall

Design with JK FF's – FF Input Eqn's

$$J_A = Bx'$$

		B			
		Bx	00	01	11
A	0	m_0	m_1	m_3	m_2
	1	m_4	m_5	m_7	m_6
		x			

$$J_A = Bx'$$

$$K_A = Bx$$

		B			
		Bx	00	01	11
A	0	m_0	m_1	m_3	m_2
	1	m_4	m_5	m_7	m_6
		x			

$$K_A = Bx$$

		B			
		Bx	00	01	11
A	0	m_0	m_1	m_3	m_2
	1	m_4	m_5	m_7	m_6
		x			

$$J_B = x$$

		B			
		Bx	00	01	11
A	0	m_0	m_1	m_3	m_2
	1	m_4	m_5	m_7	m_6
		x			

$$K_B = (A \oplus x)'$$

Design with JK FF's – Circuit

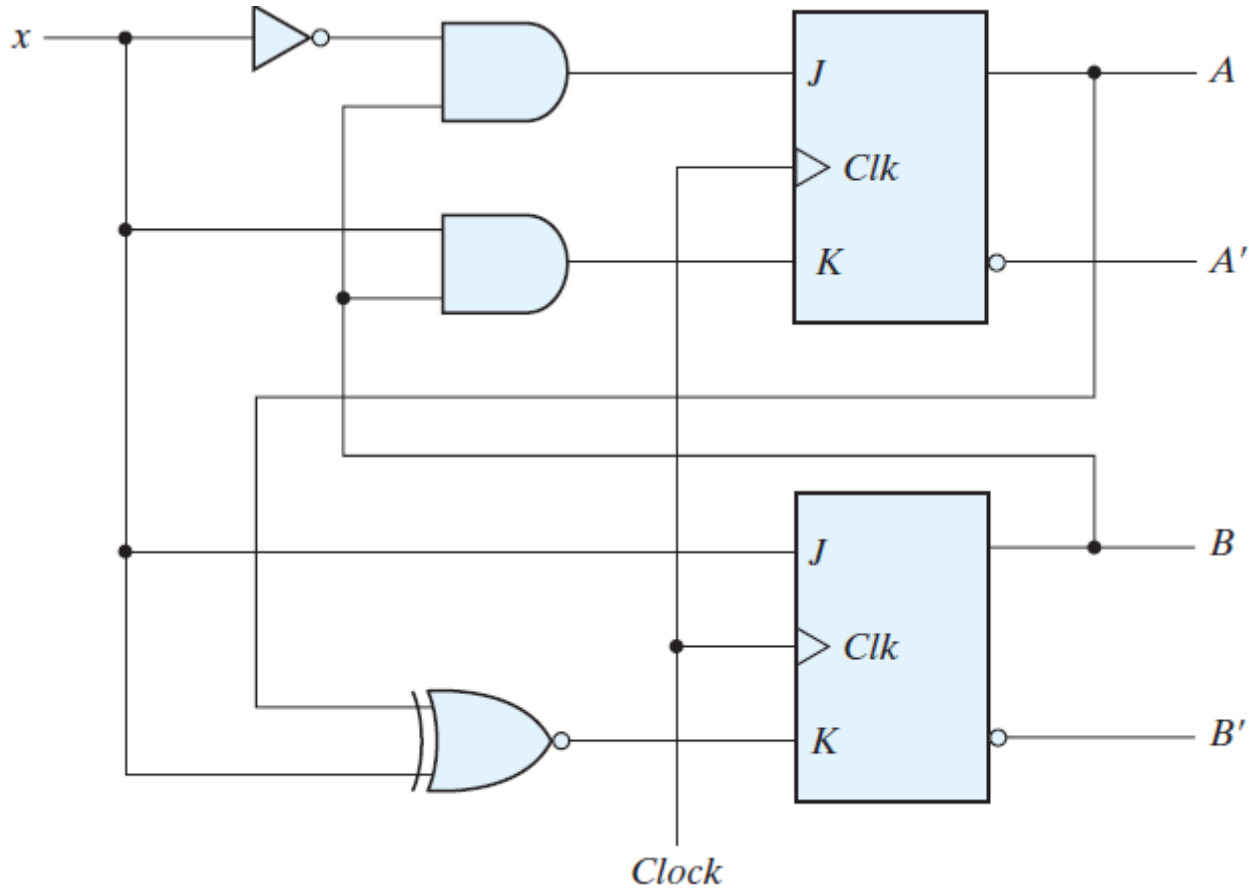

Design with T FF's

- Design the circuit for the following state diagram, a 3-bit binary counter:
 - State Diagram: no input/output, triggered by a clock edge
 - 3 T flip-flops : FF outputs map binary count
 - State table, FF Input equations, Output equations (**no output**), Circuit

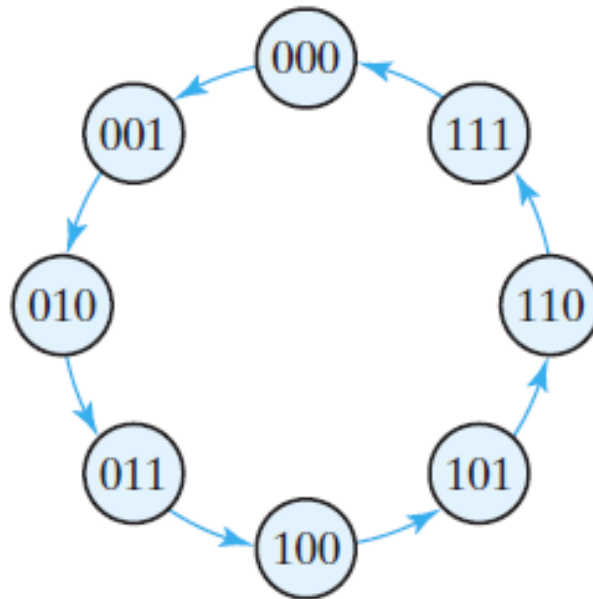

Design with T FF's – State Table

Add FF inputs in the state table to get FF input equations

Table 5.14

State Table for Three-Bit Counter

Present State			Next State			Flip-Flop Inputs		
A_2	A_1	A_0	A_2	A_1	A_0	T_{A2}	T_{A1}	T_{A0}
0	0	0	0	0	1	0	0	1
0	0	1	0	1	0	0	1	1
0	1	0	0	1	1	0	0	1
0	1	1	1	0	0	1	1	1
1	0	0	1	0	1	0	0	1
1	0	1	1	1	0	0	1	1
1	1	0	1	1	1	0	1	1
1	1	1	0	0	0	1	1	1

Design with T FF's – FF Input Equations

		A_1A_0		A_1	
		00	01	11	10
A_2	0	m_0	m_1	m_3	m_2
	1	m_4	m_5	m_7	m_6
		A_0			

$$T_{A_2} = A_1A_0$$

		A_1A_0		A_1	
		00	01	11	10
A_2	0	m_0	1	1	m_2
	1	m_4	1	1	m_6
		A_0			

$$T_{A_1} = A_0$$

		A_1A_0		A_1	
		00	01	11	10
A_2	0	1	1	1	1
	1	1	1	1	1
		x			

$$T_{A_0} = 1$$

Copyright ©2013 Pearson Education, publishing as Prentice Hall

Design with T FF's – Circuit

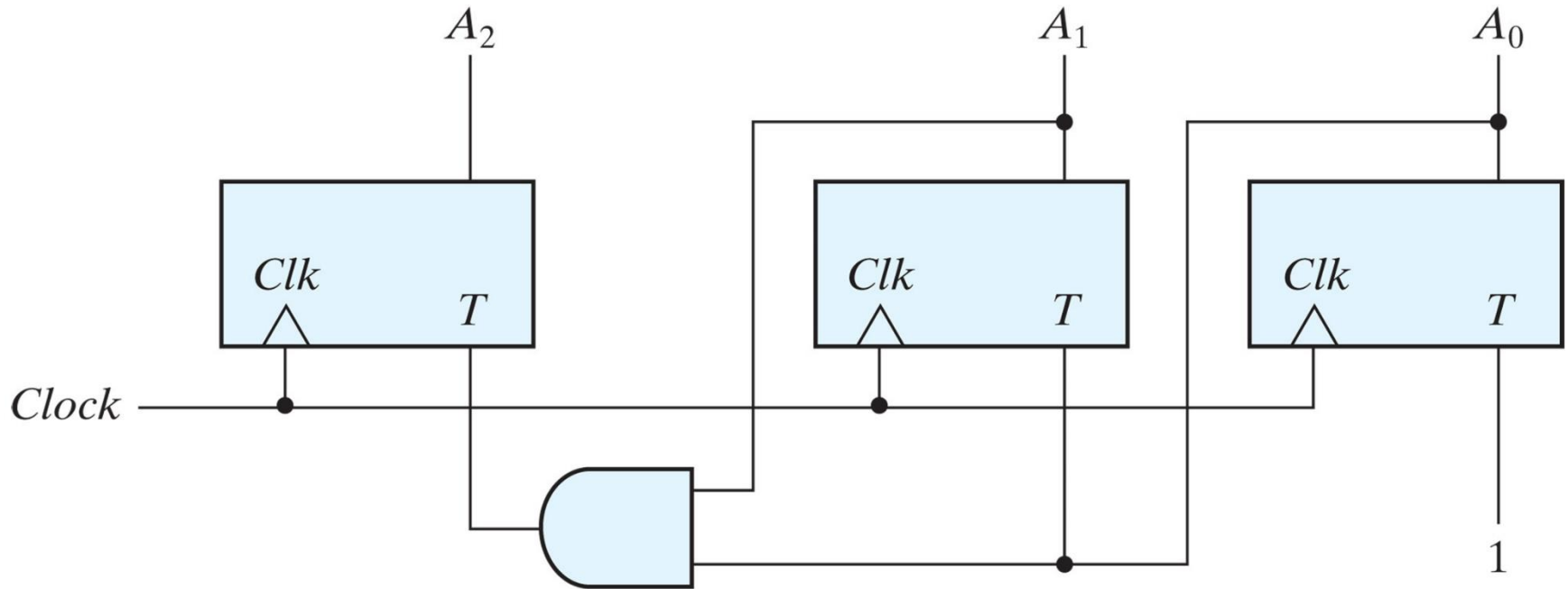

Copyright ©2013 Pearson Education, publishing as Prentice Hall

Design with JK FF's – Even Counter

- Design the circuit for the following state diagram, a 3-bit even counter
 - State table, FF Input equations, Circuit
 - What is interesting about the following state diagram?

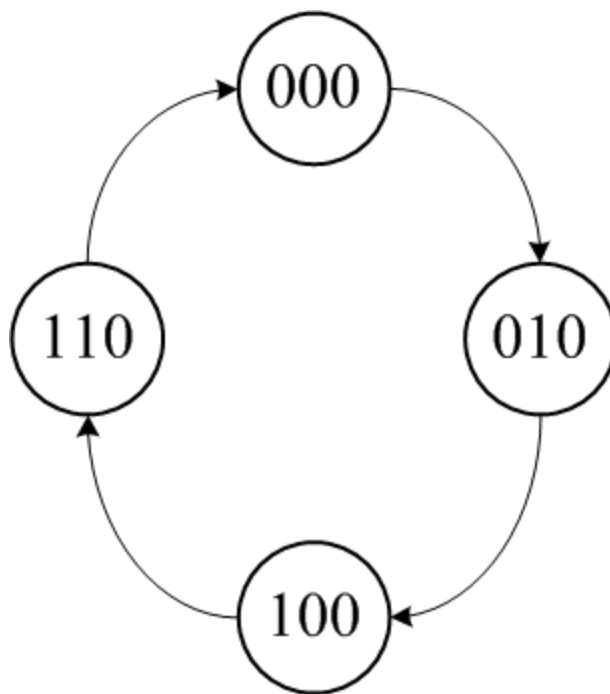

Design with JK FF's – Even Counter – State Table

Present State	Next State	JK FF Inputs					
		J_A	K_A	J_B	K_B	J_C	K_C
ABC	ABC						
000	010	0	x	1	x	0	x
001	xxx	x	x	x	x	x	x
010	100	1	x	x	1	0	x
011	xxx	x	x	x	x	x	x
100	110	x	0	1	x	0	x
101	xxx	x	x	x	x	x	x
110	000	x	1	x	1	0	x
111	xxx	x	x	x	x	x	x

Design with JK FF's – Even Counter – FF Input Eqn's

$$J_A = B$$

A \ Bx	00	01	11	10
0	m_0	m_1	m_3	m_2
		X	X	1
1	m_4	m_5	m_7	m_6
	X	X	X	X

$$K_A = B$$

A \ Bx	00	01	11	10
0	m_0	m_1	m_3	m_2
	X	X	X	X
1	m_4	m_5	m_7	m_6
		X	X	1

$$J_B = 1$$

$$K_B = 1$$

$$J_c = 0$$

$$K_c = 1$$

Design with JK FF's – Even Counter – Circuit

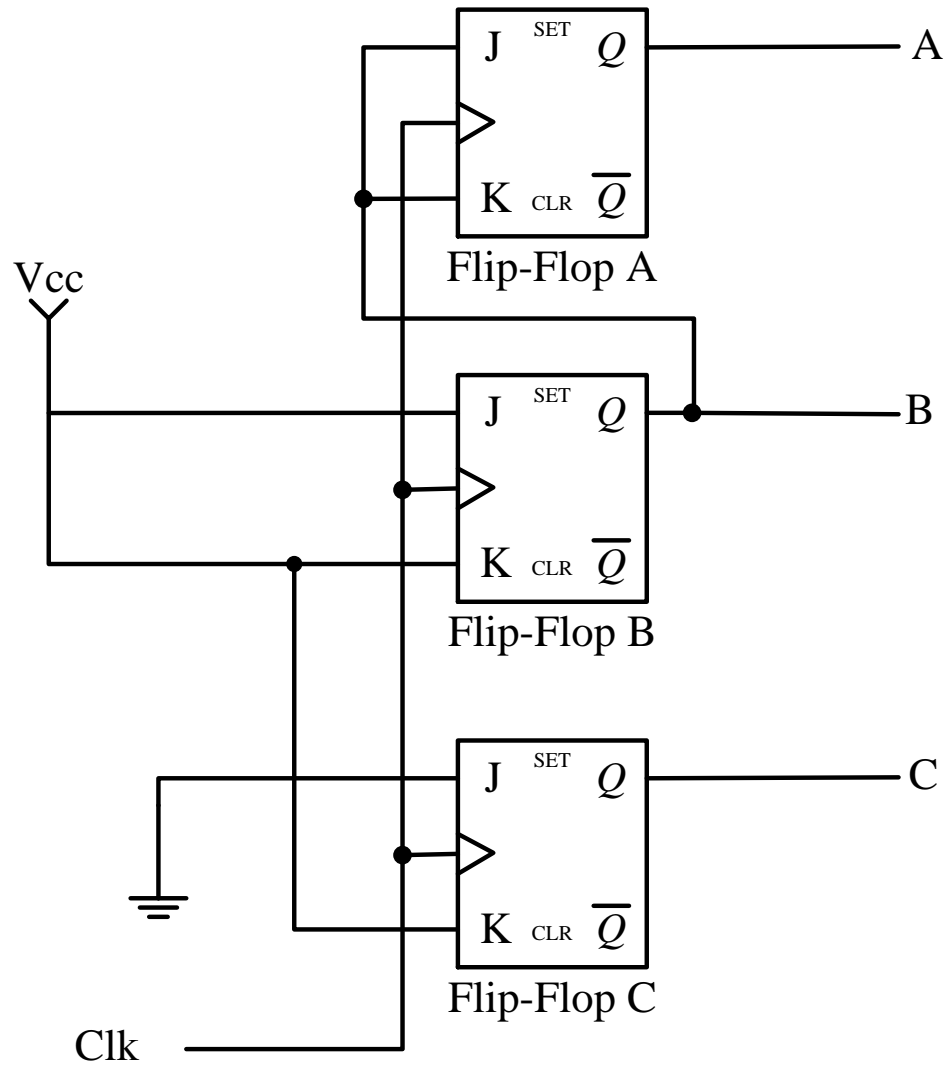

Design with JK FF's – Even Counter - Alternate

- Design the circuit for the following state diagram, a 3-bit event counter
 - State table, FF Input equations, Circuit
 - What is interesting about the following state diagram.
 - Can you deduce the circuit directly?
 - What would our design give us?

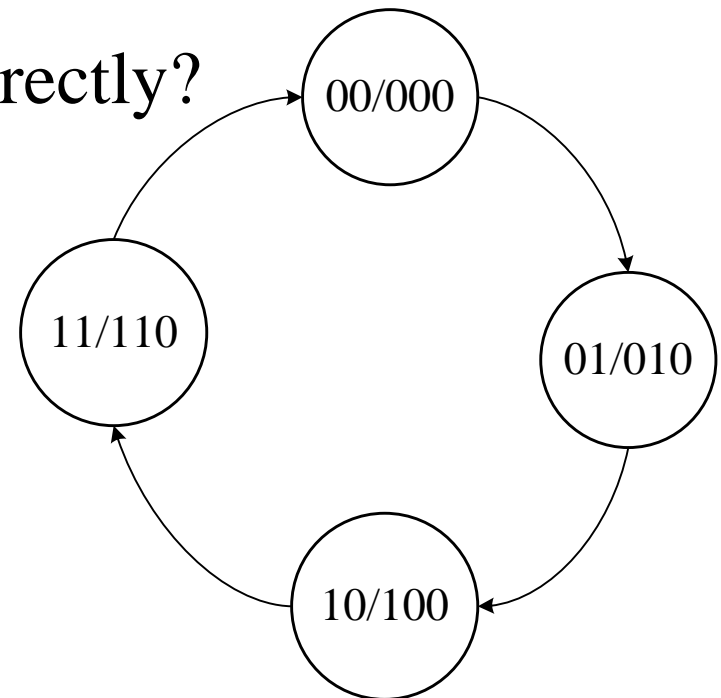

Design with JK FF's – Even Counter (alt) - Circuit

- Circuit deduced directly from the state diagram

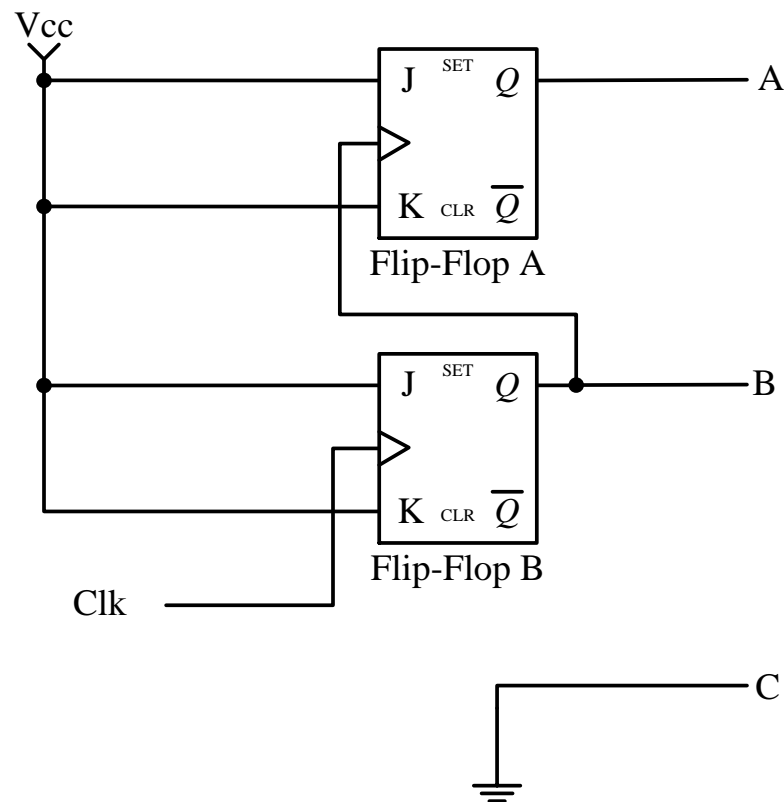
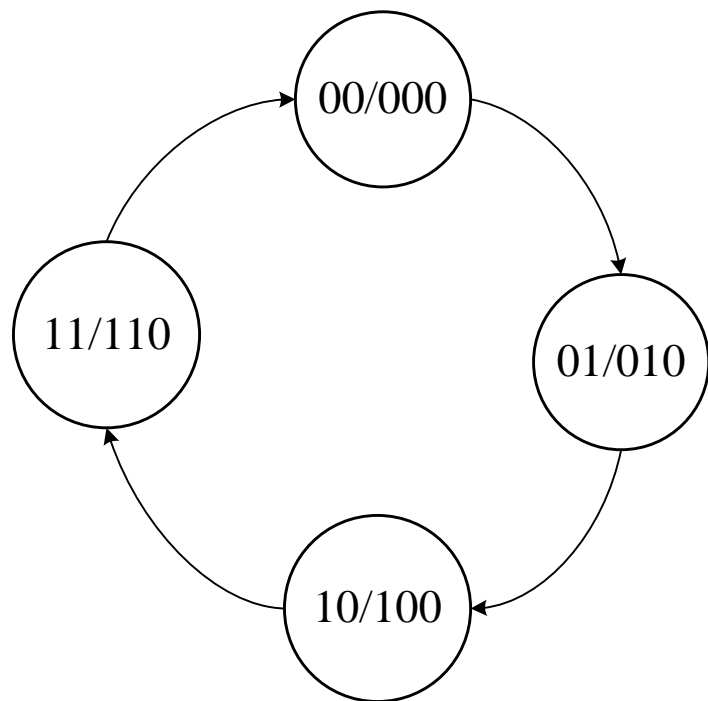

Design with JK FF's – Even Counter (alt) - Circuit

- Modified original circuit.
- Check with design.

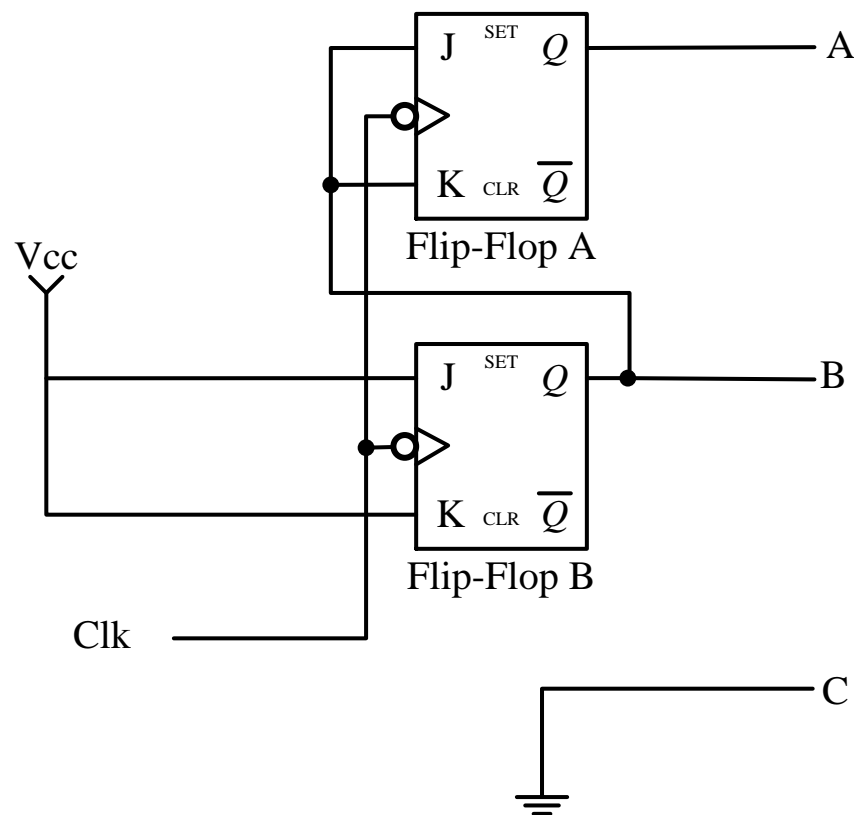
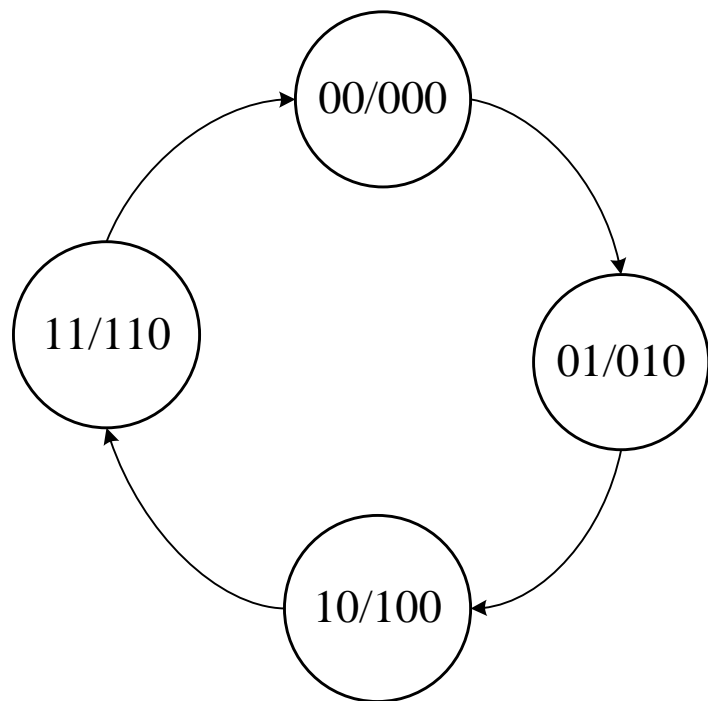

Appendix

Edge Sensitive SR

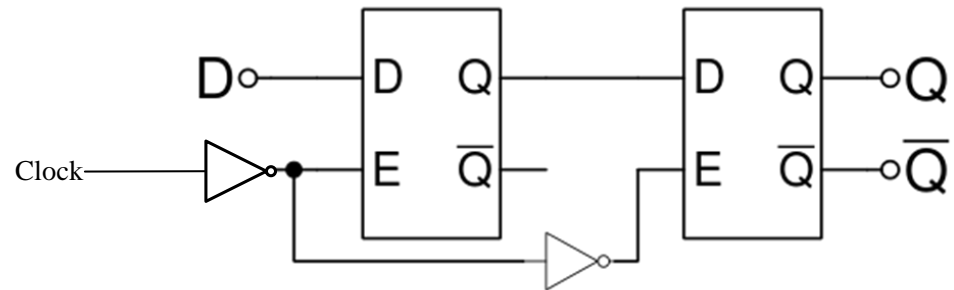
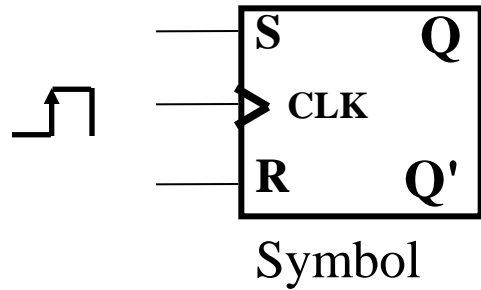

Characteristic Table

S	R	C	$Q(n+1)$	Comment
0	0	\uparrow	$Q(n)$	No Change
0	1	\uparrow	0	Reset
1	0	\uparrow	1	Set
1	1	\uparrow	?	Forbidden
x	x	x	$Q(n)$	No Change

- Q_n = state *before* positive edge
- Q_{n+1} = state *after* positive edge

JK Flip Flop Implementation by SR Flip Flop

Symbol

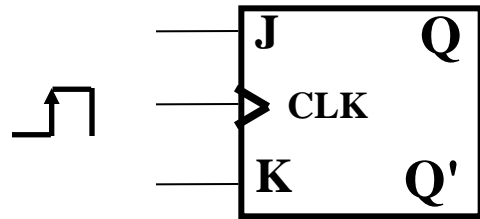

Same as SR except for
 $K=J=1$ the JK flip flop will
 Output the opposite state of
 Q_n .

If $Q_n = 1$ then $Q_{n+1} = 0$

If $Q_n = 0$ then $Q_{n+1} = 1$

Characteristic Table

J	K	C	$Q(n+1)$	Function
0	0	\uparrow	$Q(n)$	No Change
0	1	\uparrow	0	Reset
1	0	\uparrow	1	Set
1	1	\uparrow	$Q'(n)$	Toggle
x	x	x	$Q(n)$	No Change

- Q_n = state *before* positive edge
- Q_{n+1} = state *after* positive edge

