

MECH 211 – Mechanical Engineering Drawing

François Tardy

Credits: 3.5

Lecture 2

Lecture Content

- Drawing instruments and practices.
 - Graphic constructions; more during the tutorial period.
 - Computer Aided Design (CAD) Tools:
 - CAD comprehensive tools
 - Demonstration on AutoCAD
- 

Assignments

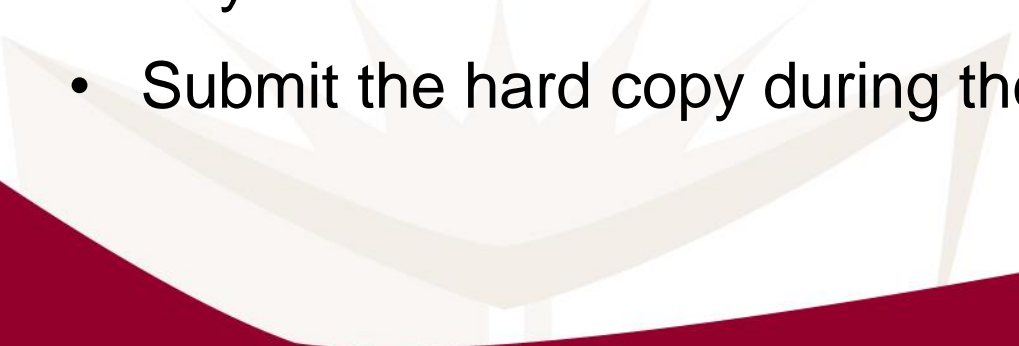
- This week you will begin to solve assignments (there are 10 sets of 4 problems selected from the textbook).
 - Attempt to solve the assignments using AutoCAD during tutorials.
 - Once at home, you have to re-solve the problems using paper and drawing instruments.
 - Pay attention to the neatness of the drawing.
 - Submit the hard copy during the tutorial.
- 

Drawing Instruments

- Depending on the practice condition.
- Basic representations performed with freehand style.
- Sketching requires paper and pencils.
- To-scale sketching requires drafting tools.
- Component design – CAD tools:
 - Changes can be made quickly
 - Solid models are created
 - Analysis is carried out with minimal effort
 - Portable

Drafting Tools

Engineering drafting tools



Parallel Rulers

- Used to draw straight lines,
- Provide support to squares for lining (hatching).

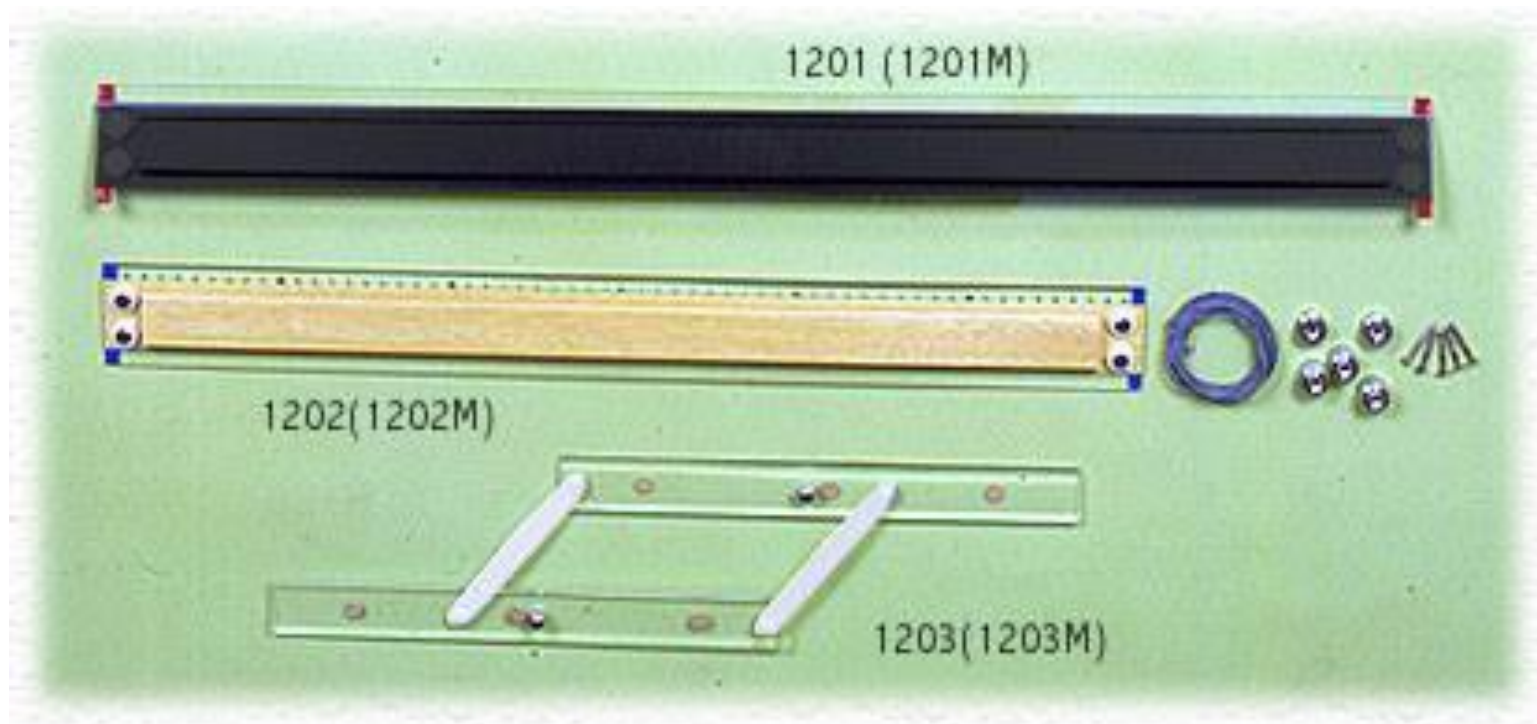

Squares (45°, 30°/60°)

- Draws straight perpendicular lines,
- Draws parallel lines to a specific direction,
- Essential tools for making accurate draft drawings.

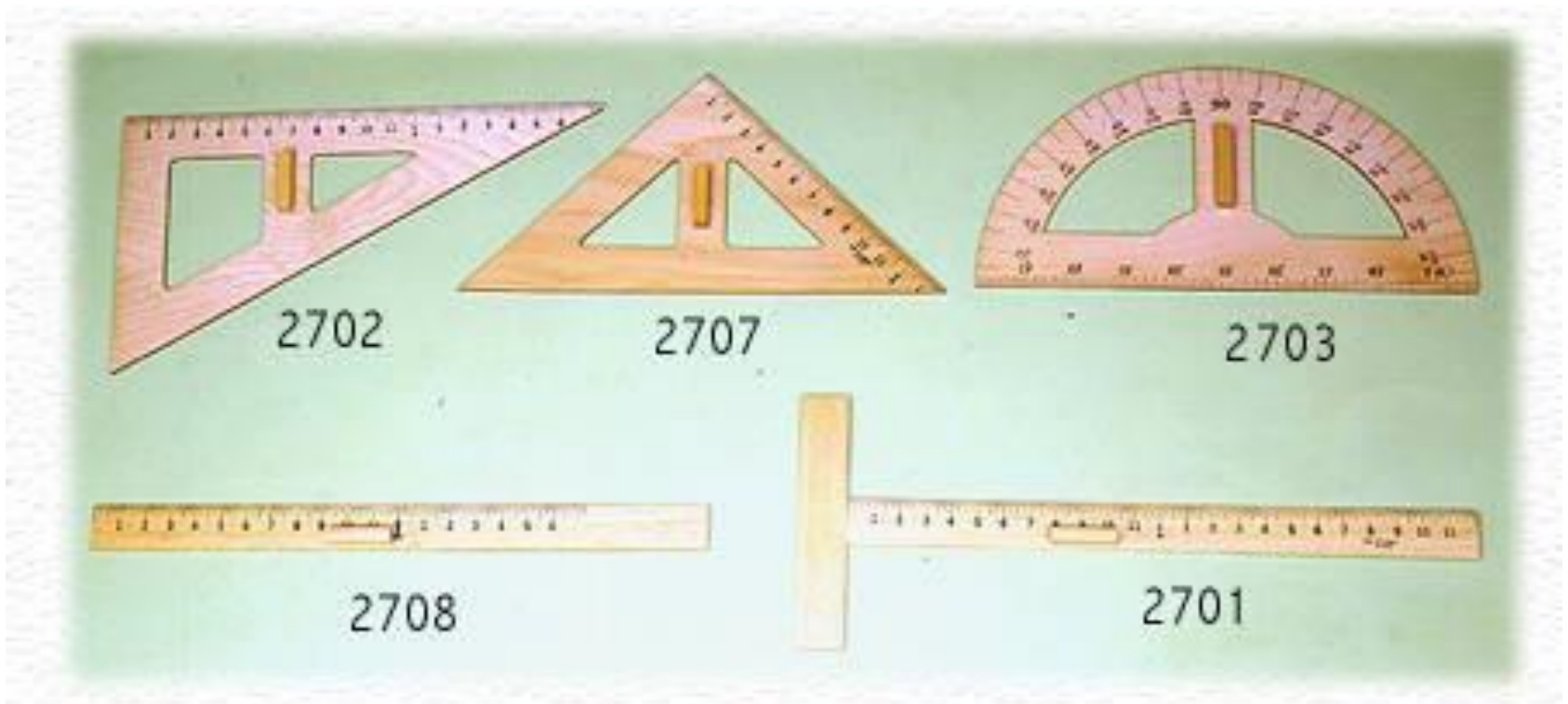

Compasses, dividers

Used to draw circles and arcs.

Used to perform geometric constructions: divisions, measurements, copying of dimensions.

Used to draw specific angles:

30° , 60° , 45° , 90°



Protractors, T-Squares, Splines

Measure angles, maintain a fixed direction, connect two lines by a curve.

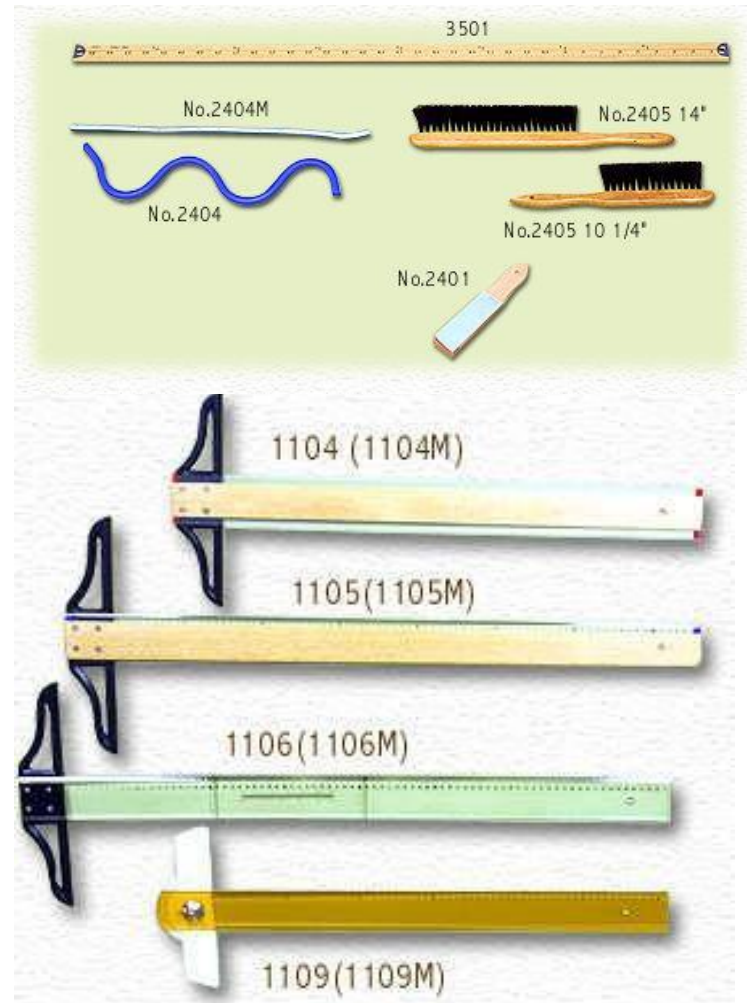
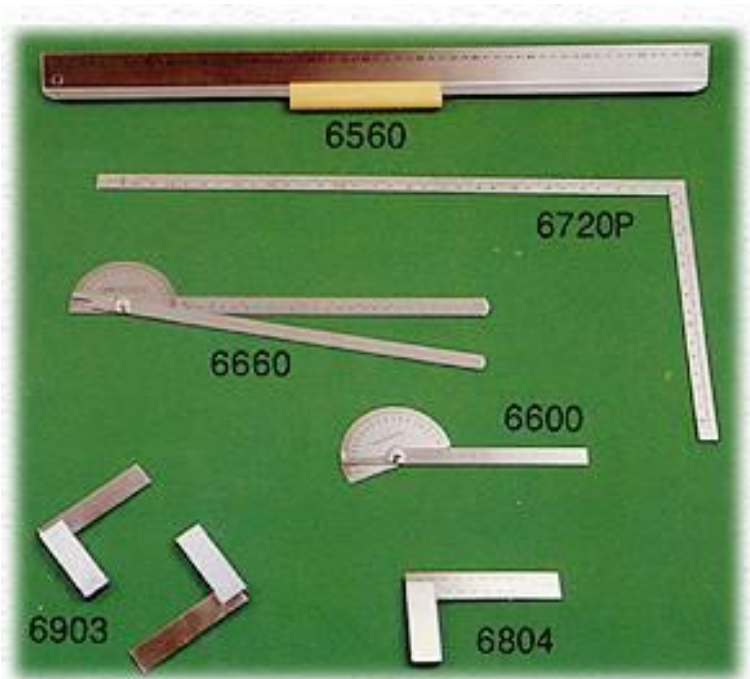

GEE... I WONDER WHAT
THEY'LL THINK UP OF NEXT!!



©1993, Vikram Madan. All Rights reserved

©1993 Vikram Madan

Drawing helps to think in 3D

“Everything that can be invented has been invented.”

Quote attributed to commissioner Charles H. Duell, Director of the US Patents Office, 1899.

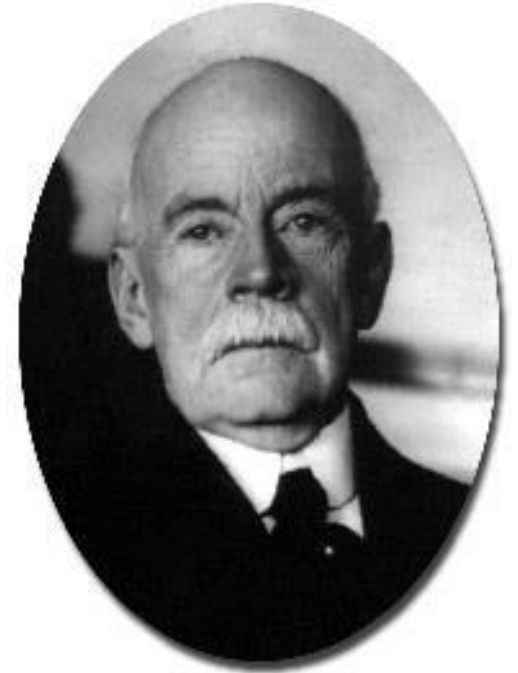

Why learn to use drafting tools?

- CAD Tools are not easily available – powerful computers and software are required.
 - Enhances the designer's capability to perform better quality free hand sketching.
 - Some jobs could be more easily done by using graphics tools.
 - Hand drawing is another skill that the designer must acquire.
- 

Why learn to do free-hand sketching?

- Ideation, conceptual proofing and technical dialogue all require free-sketching abilities.
- Often, initial conceptual sketches are carried out outside an office.
- Added skills for designers.



Free hand sketching

- Make a sketch without rulers, triangles or compasses: only by free hand.
- Include all the needed information within the sketch in order to convey or understand when reviewing an idea.
- Free hand sketching is associated with the ideation – the initial stage of creation of a new product



Free hand sketching

Example

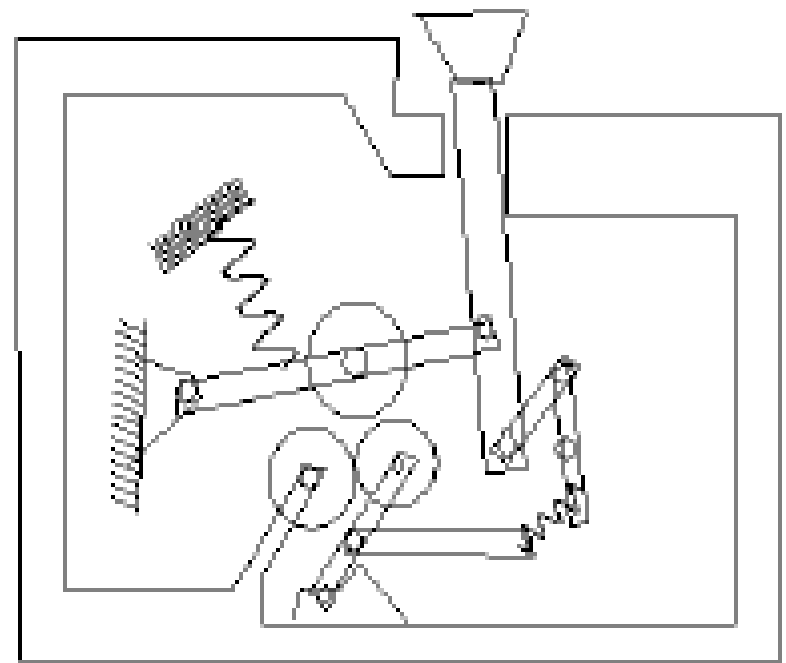
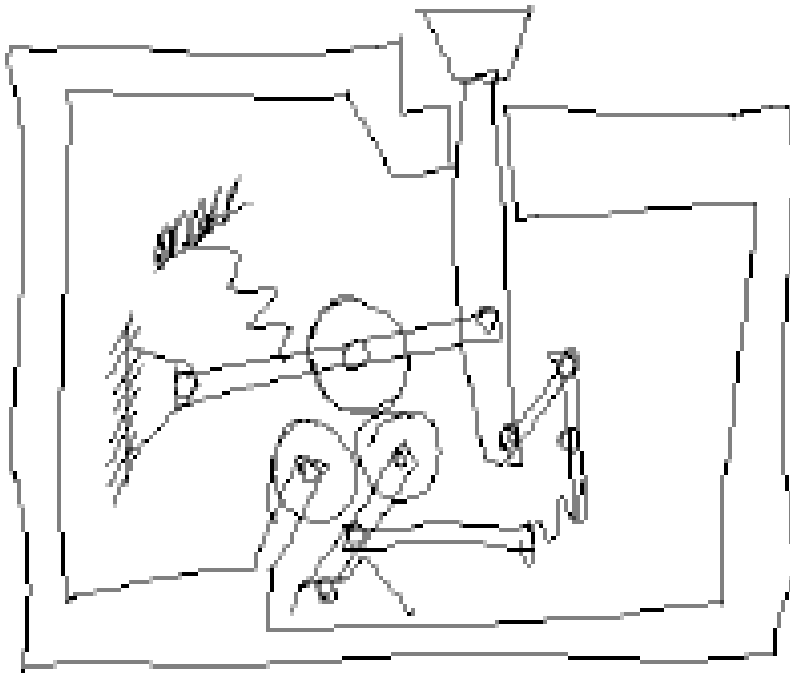

Free hand sketching

Different sketches could be made for various level of detail.

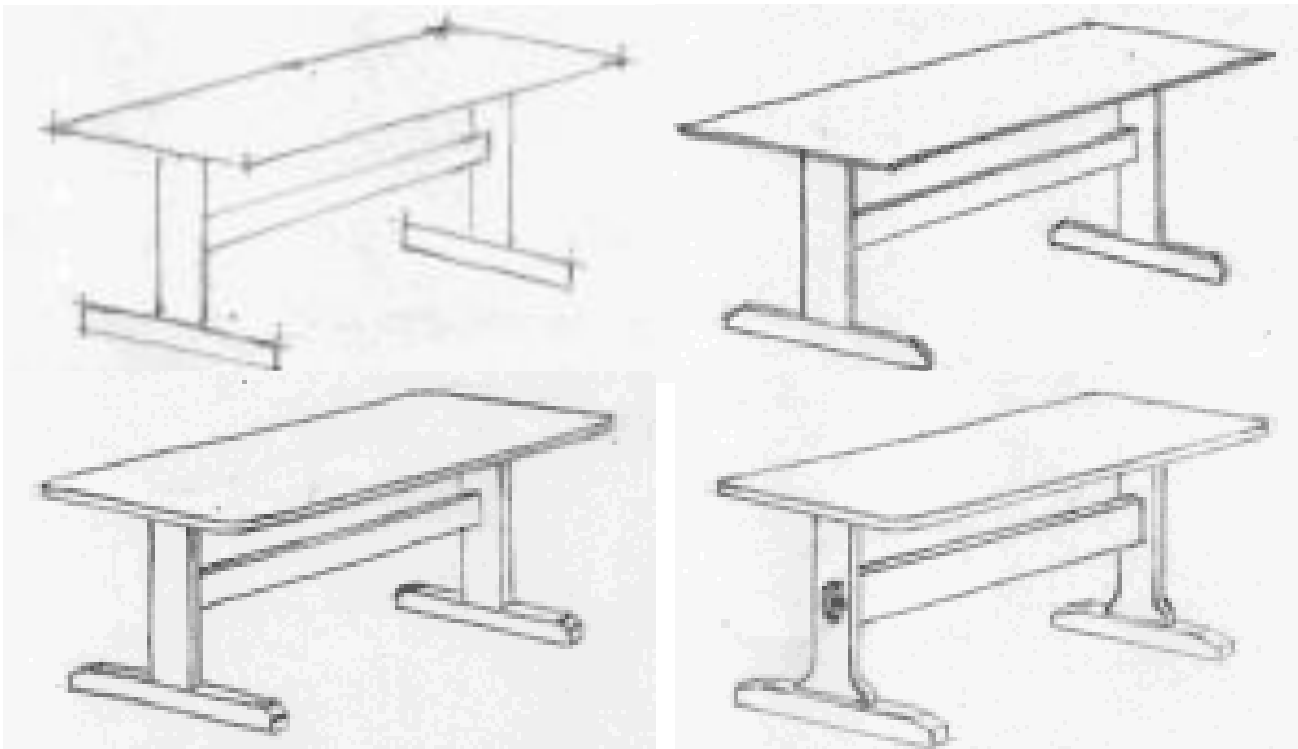

Free hand sketching

Projection type is also important.

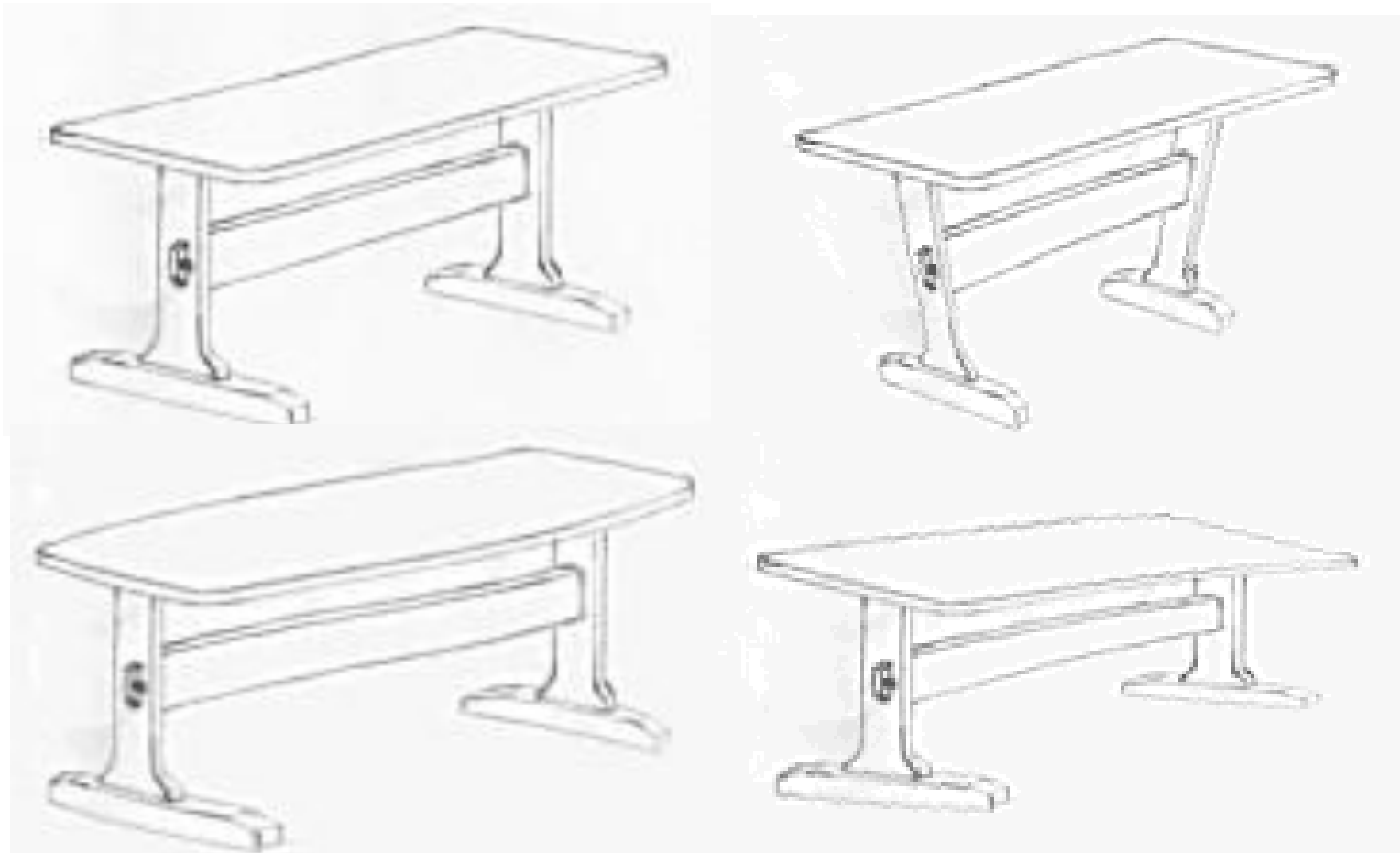

Freehand sketching

The ultimate objective – the working drawing production.

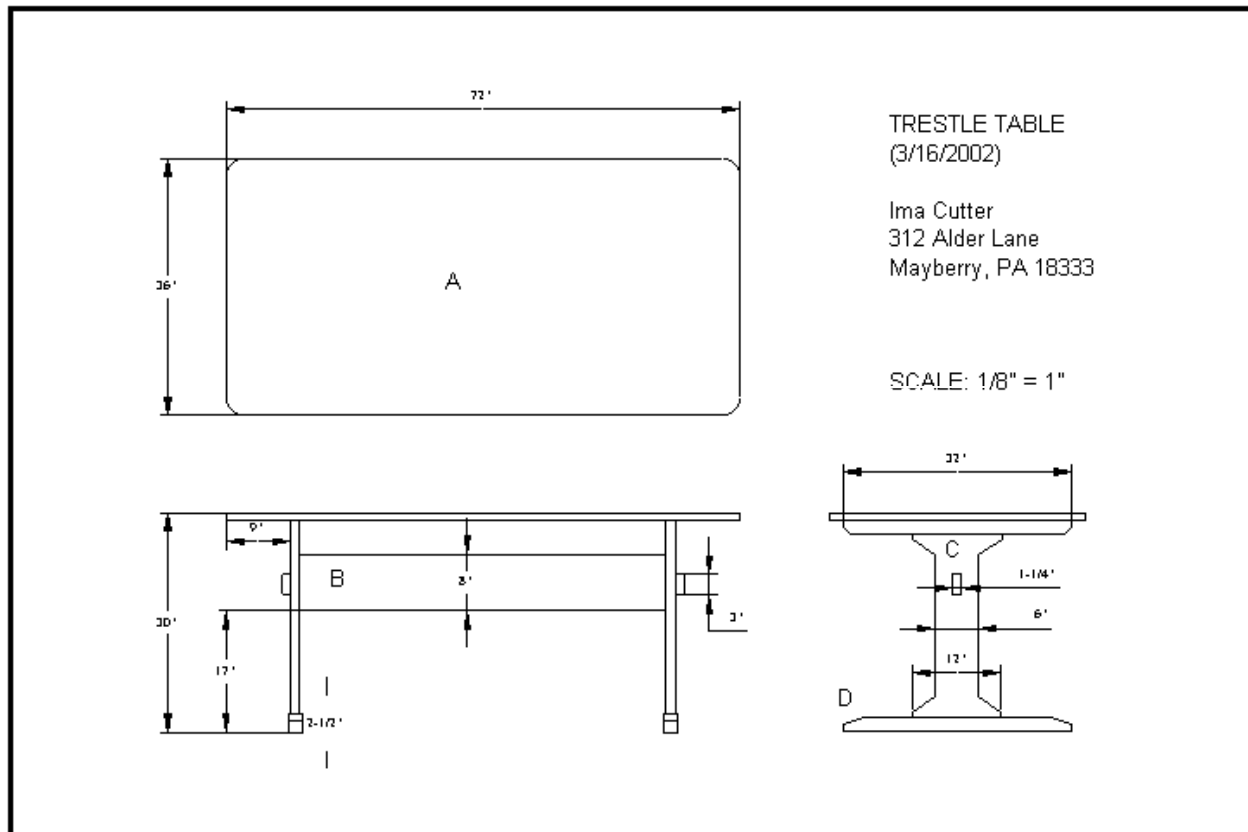

Freehand sketching

- How do we practice it?
- Select objects that you could sketch for various levels of detailing – and DRAW THEM!
- Try to represent one of your ideas on a new product (say, a car, a boat, an airplane, etc.). After production, ask one of your colleagues to have a look and tell you what he understands out from your sketch



Graphic constructions

EXAMPLES: Making use of the drawing tools only, draw:

- Line perpendicular to a segment passing through the middle point
- Bisection line of an angle
- Tri-section lines of a 90° angle
- A hexagon inscribed into a given circle
- A point on a segment that divides the line in a given ratio

Graphic Construction Example

Given the segment AB , draw a line perpendicular to the direction AB passing through the middle of the segment AB .



Graphic Construction Example

Given the segment AB, draw a line perpendicular to the direction AB passing through the middle of the segment AB.

With the compasses in the point A and B respectively and opened larger than half the segment, draw two arcs, one above, one below the segment.

Maintain the opening of the compasses while moving the center from one point to the other.

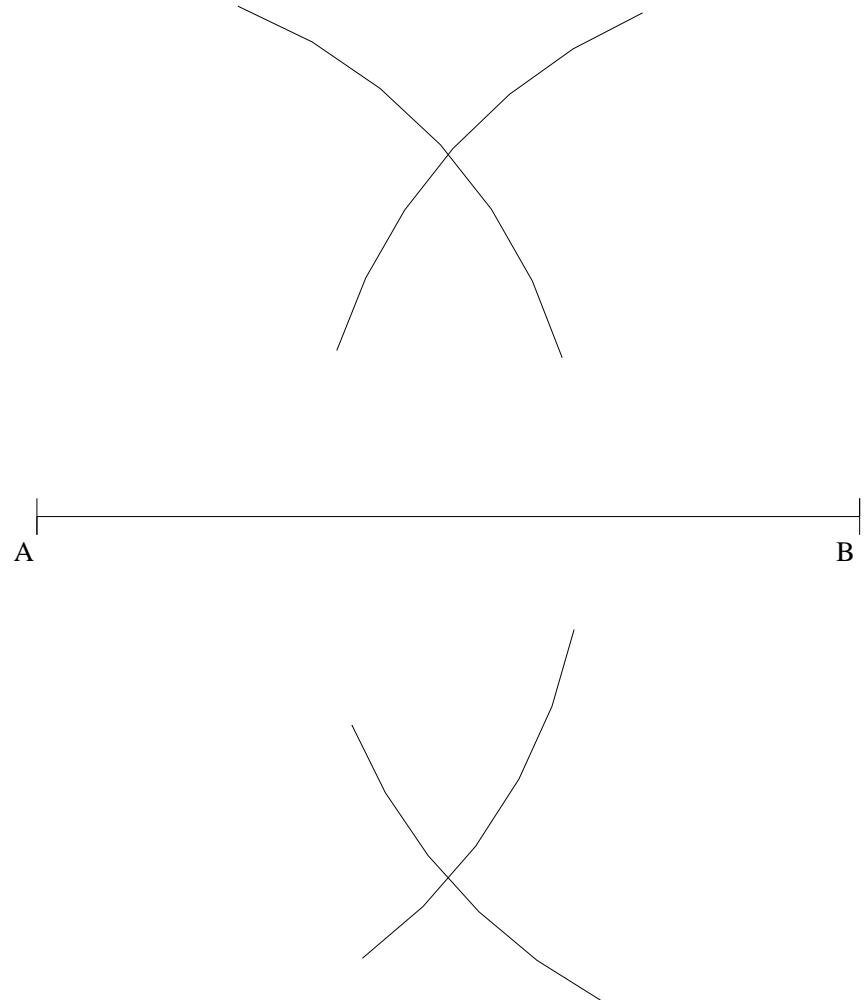

Graphic Construction Example

Given the segment AB, draw a line perpendicular to the direction AB passing through the middle of the segment AB.

With the compasses in the point A and B respectively and opened larger than half the segment, draw two arcs, one above, one below the segment.

Maintain the opening of the compasses while moving the center from one point to the other.

The segment MN is the line that is asked for.

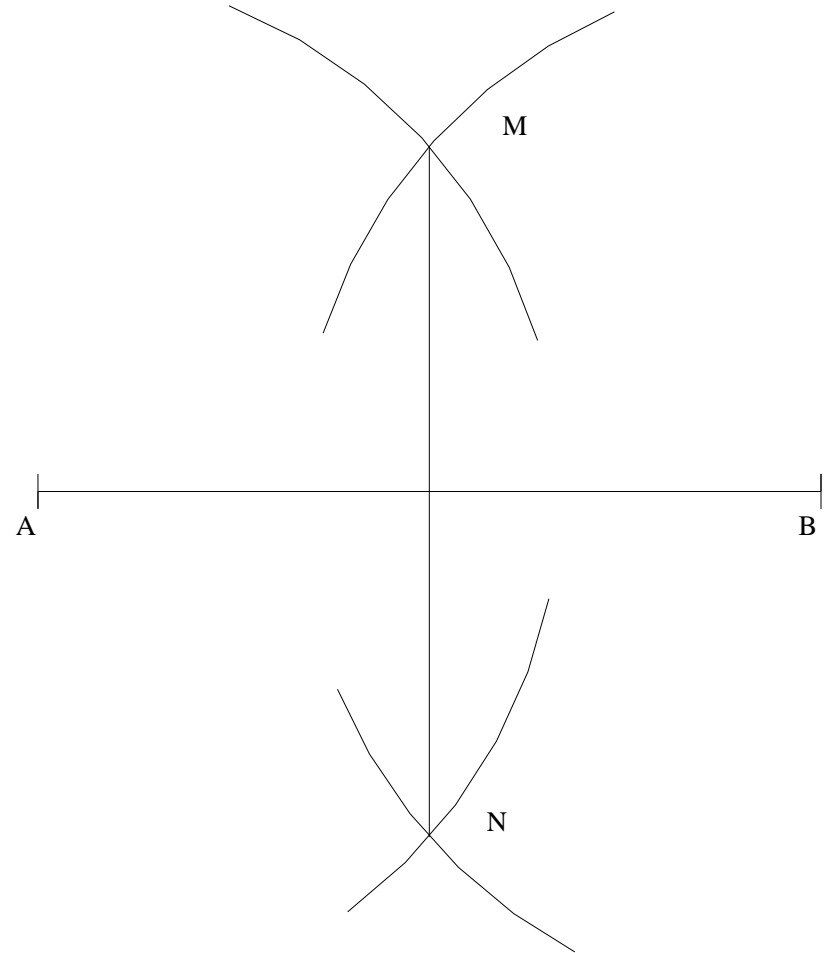

Graphic Construction Example

Given the segment AB, draw a line perpendicular to the direction AB passing through the middle of the segment AB.

With the compasses in the point A and B respectively and opened larger than half the segment, draw two arcs, one above, one below the segment.

Maintain the opening of the compasses while moving the center from one point to the other.

Segment MN is the desired line.

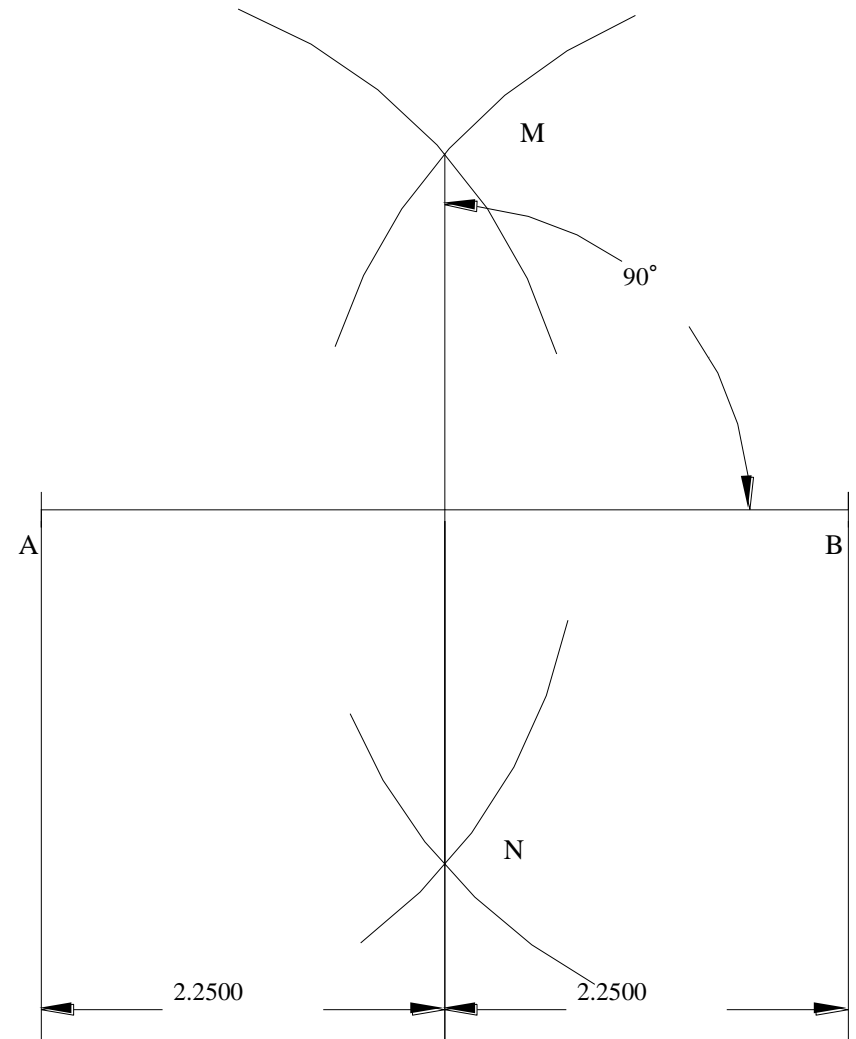

Graphic Construction Example 2

Given an angle, find the line that passes through point O and divides the angle in two equal parts.

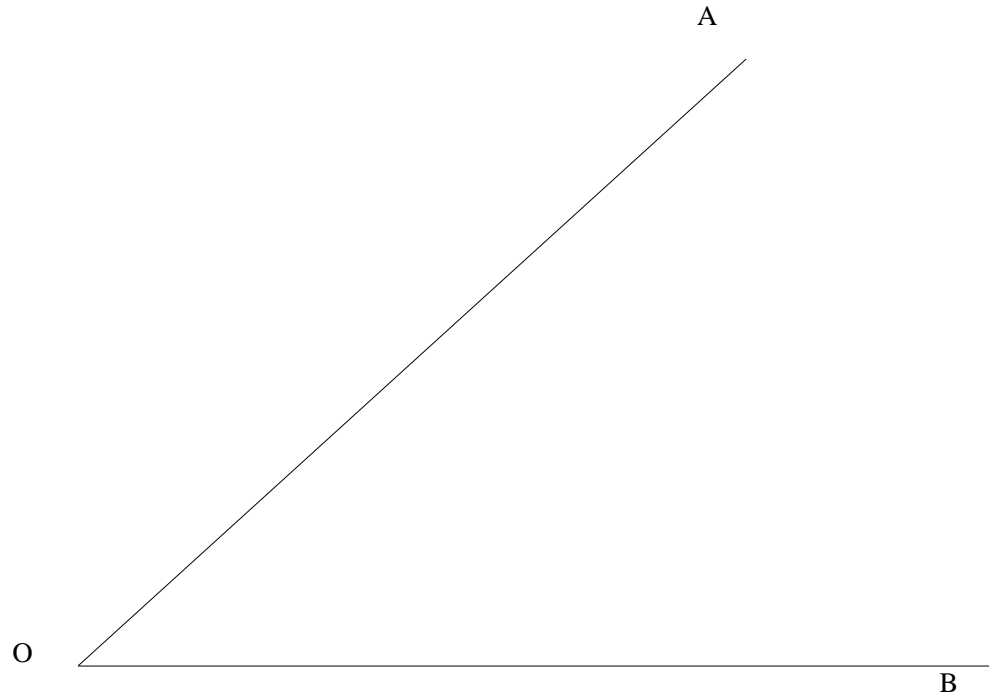

Graphic Construction Example 2

Given an angle, find the line that passes through point O and divides the angle in two equal parts.

With a convenient opening in the compass, draw an arc with the centre in O and that intersects both OA and OB.

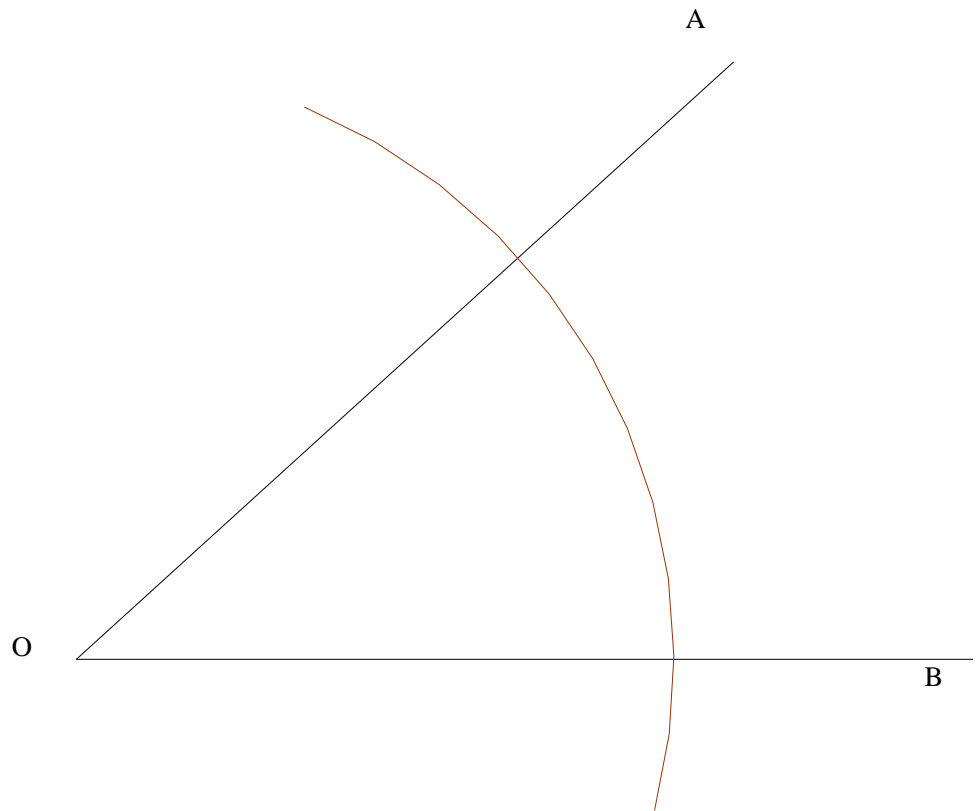

Graphic Construction Example 2

Given an angle, find the line that passes through point O and divides the angle in two equal parts.

With a convenient opening in the compass, draw an arc with the centre in O and that intersects both OA and OB.

With same or another convenient opening in the compasses, larger than half of the core of the arc, draw two arcs with the centres located in the previous point of intersection.

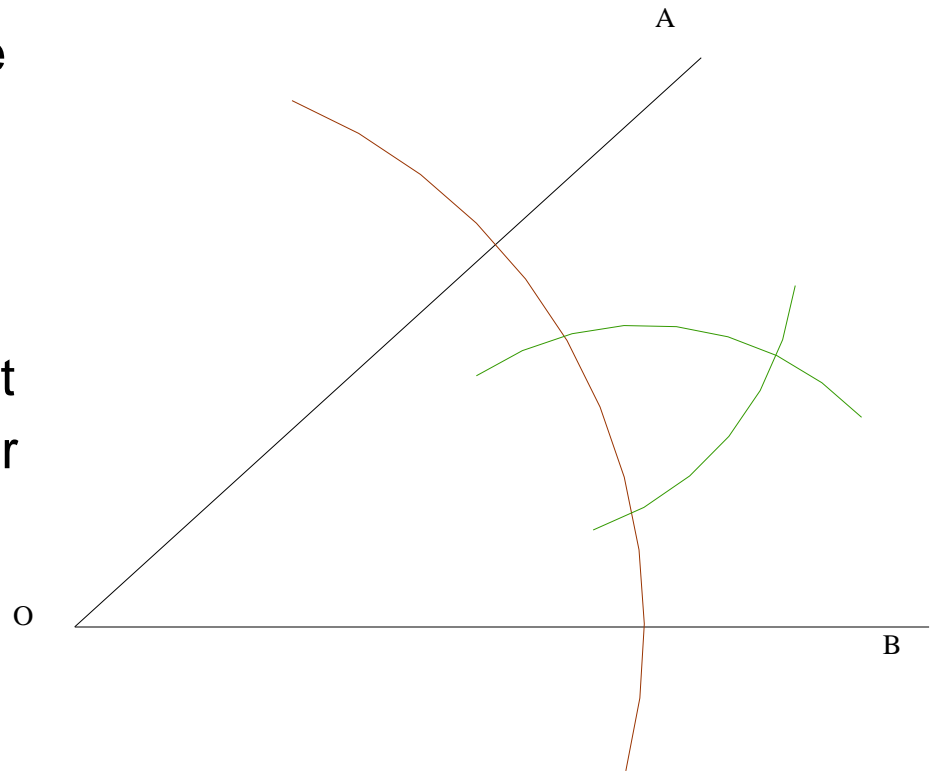

Graphic Construction Example 2

Given an angle, find the line that passes through point O and divides the angle in two equal parts.

With a convenient opening in the compass, draw an arc with the centre in O and that intersects both OA and OB.

With same or another convenient opening in the compasses, larger than half of the core of the arc, draw two arcs with the centres located in the previous point of intersection.

B The line that connects the point O with the last intersection point, as shown in figure is the bisector line of the angle.

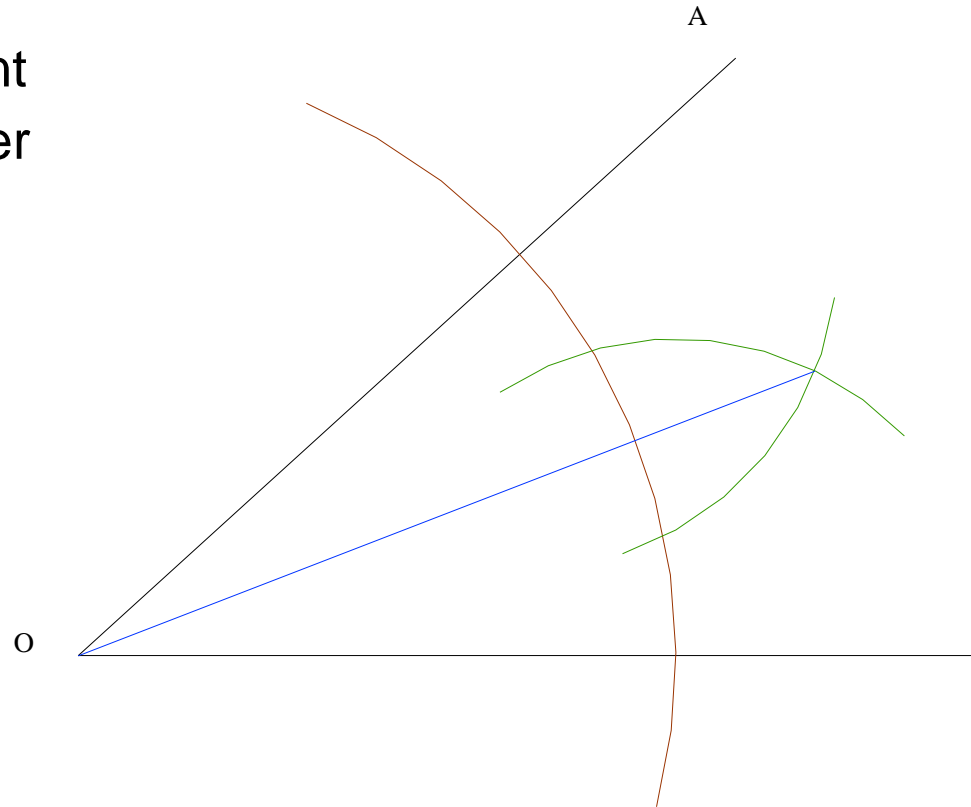

Graphic Construction Example 3

Given the 90° angle, find two lines that pass through the point O and divide the angle in three equal angles (30° each).

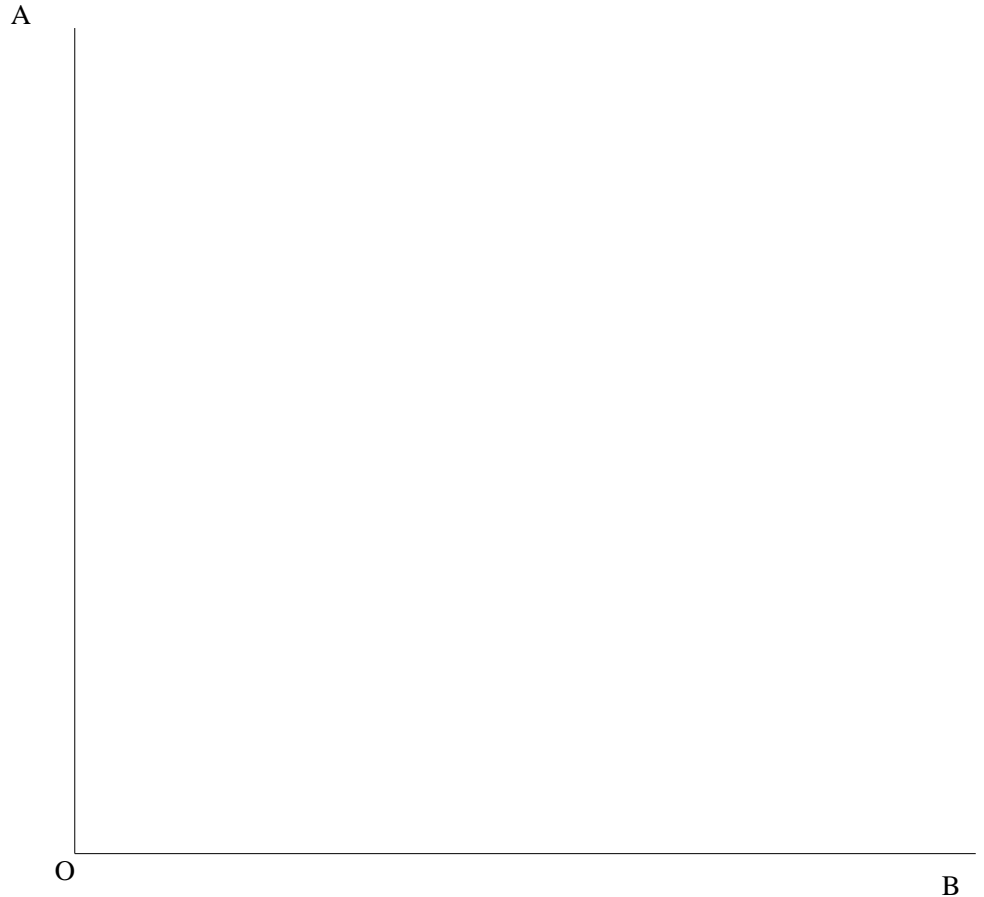

Graphic Construction Example 3

Given the 90° angle, find two lines that pass through the point O and divide the angle in three equal angles (30° each).

With a convenient opening of the compasses, draw a continuous arc with centre in O that cuts both segments OA and OB through the shortest distance.

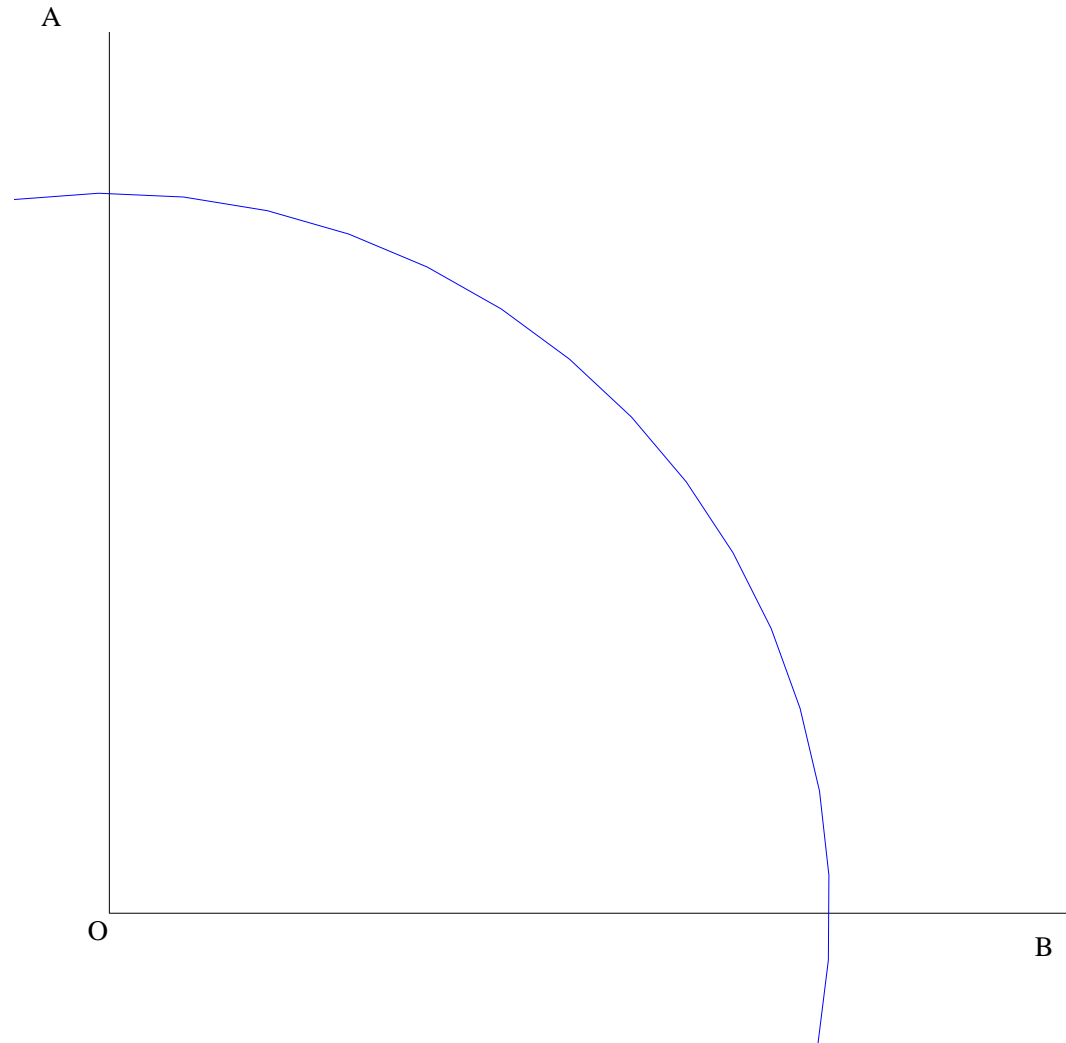

Graphic Construction Example 3

Given the 90° angle, find two lines that pass through the point O and divide the angle in three equal angles (30° each).

With a convenient opening of the compasses, draw a continuous arc with centre in O that cuts both segments OA and OB through the shortest distance.

Maintaining the same opening of the compasses, draw arcs to cut the previously drawn arc with the centre at the intersections of the arc with OA and OB respectively.

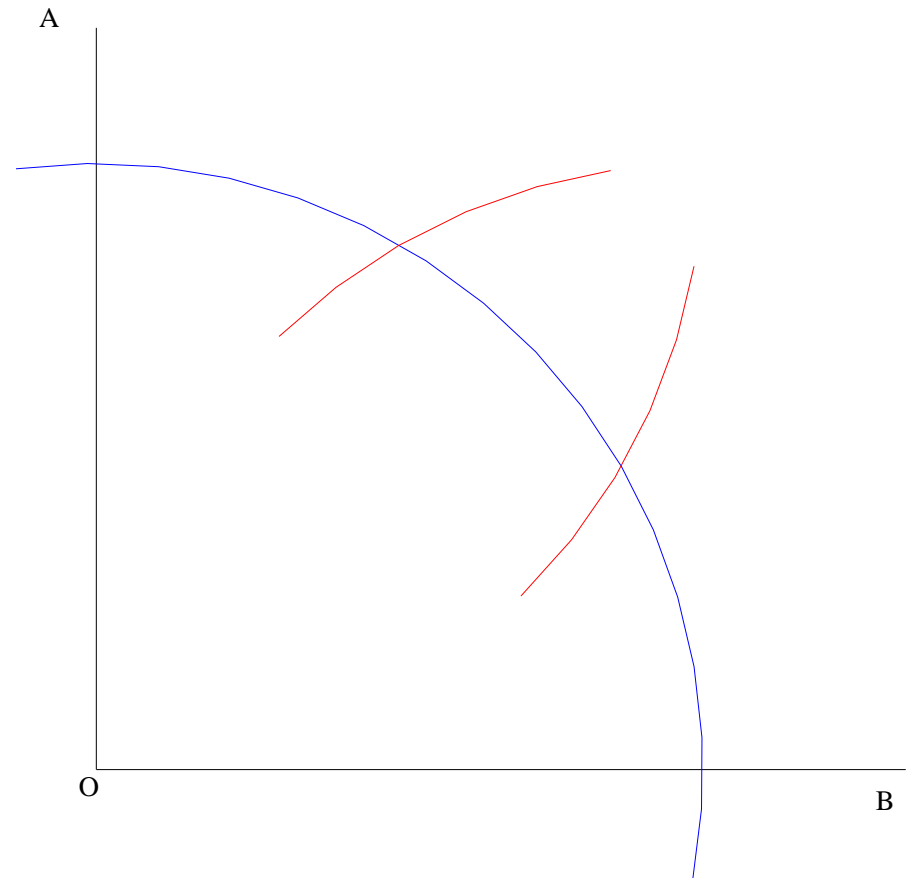

Graphic Construction Example 3

Given the 90° angle, find two lines that pass through the point O and divide the angle in three equal angles (30° each).

With a convenient opening of the compasses, draw a continuous arc with centre in O that cuts both segments OA and OB through the shortest distance.

Maintaining the same opening of the compasses, draw arcs to cut the previously drawn arc with the centre at the intersections of the arc with OA and OB respectively.

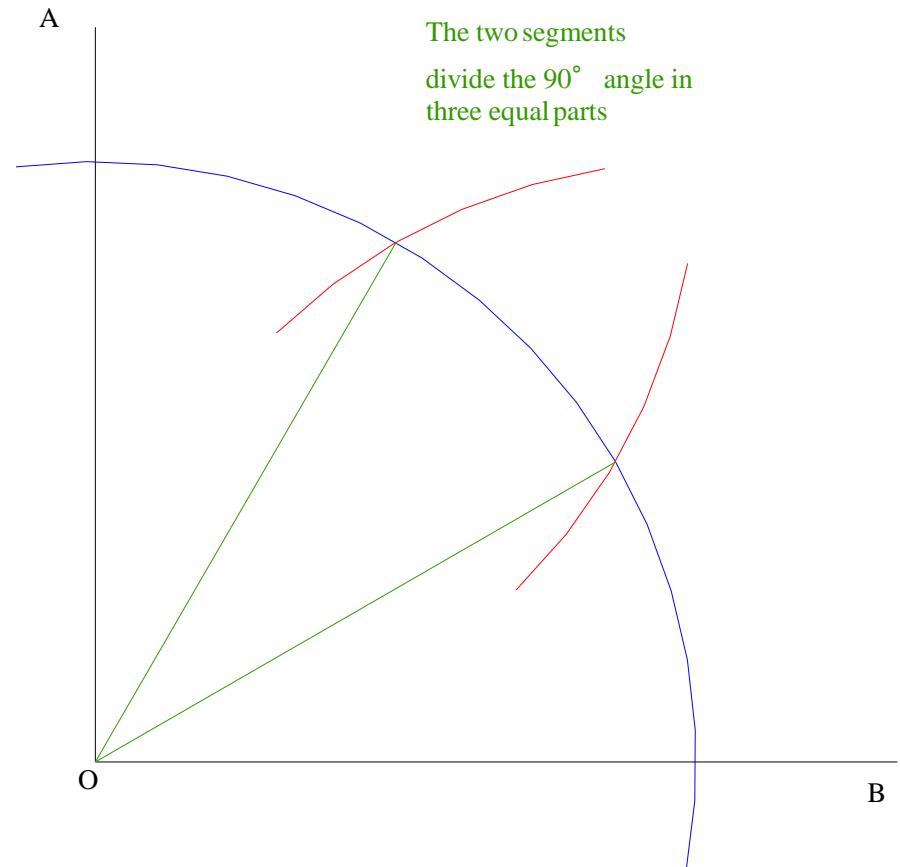

Graphic Construction Example 4

Given a circle of radius R , inscribe a hexagon inside the circle.

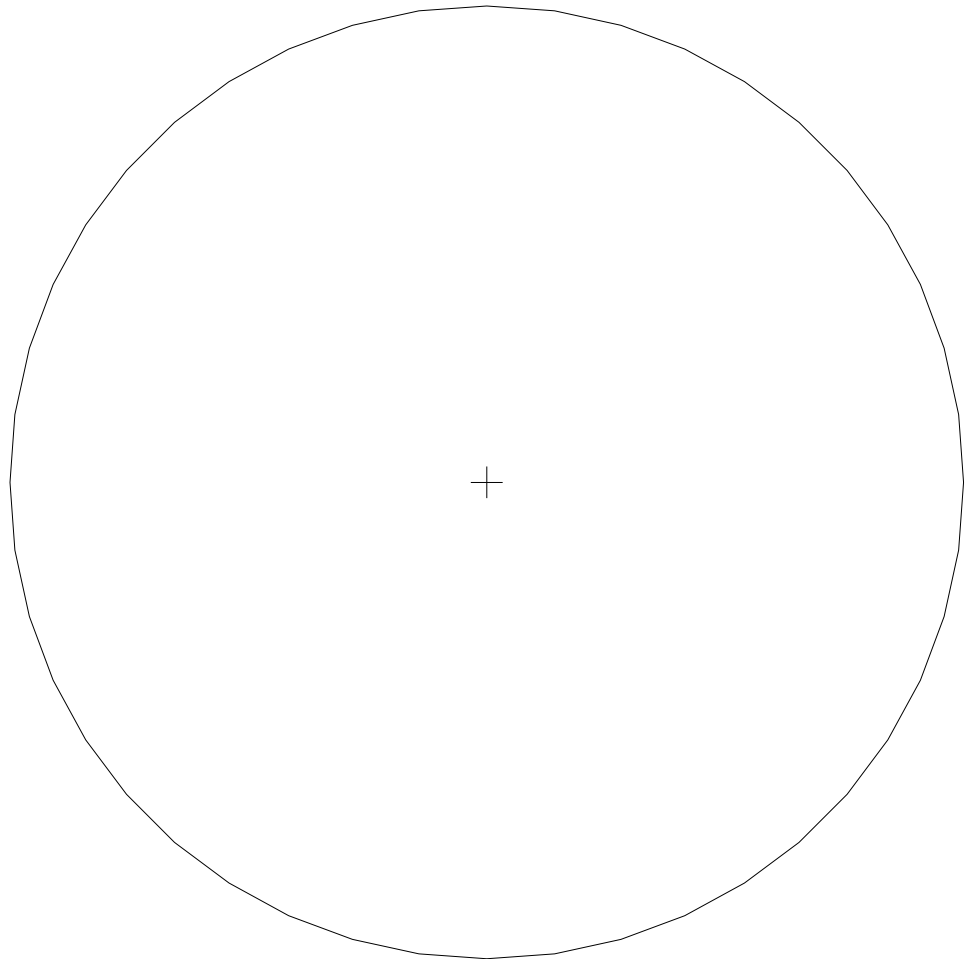

Graphic Construction Example 4

Given a circle of radius R , inscribe a hexagon inside the circle.

Draw two perpendicular diameters that pass through the centre of the circle. Select one of the diameters as the reference. Two of the sides of the hexagon will be perpendicular to the other diameter.

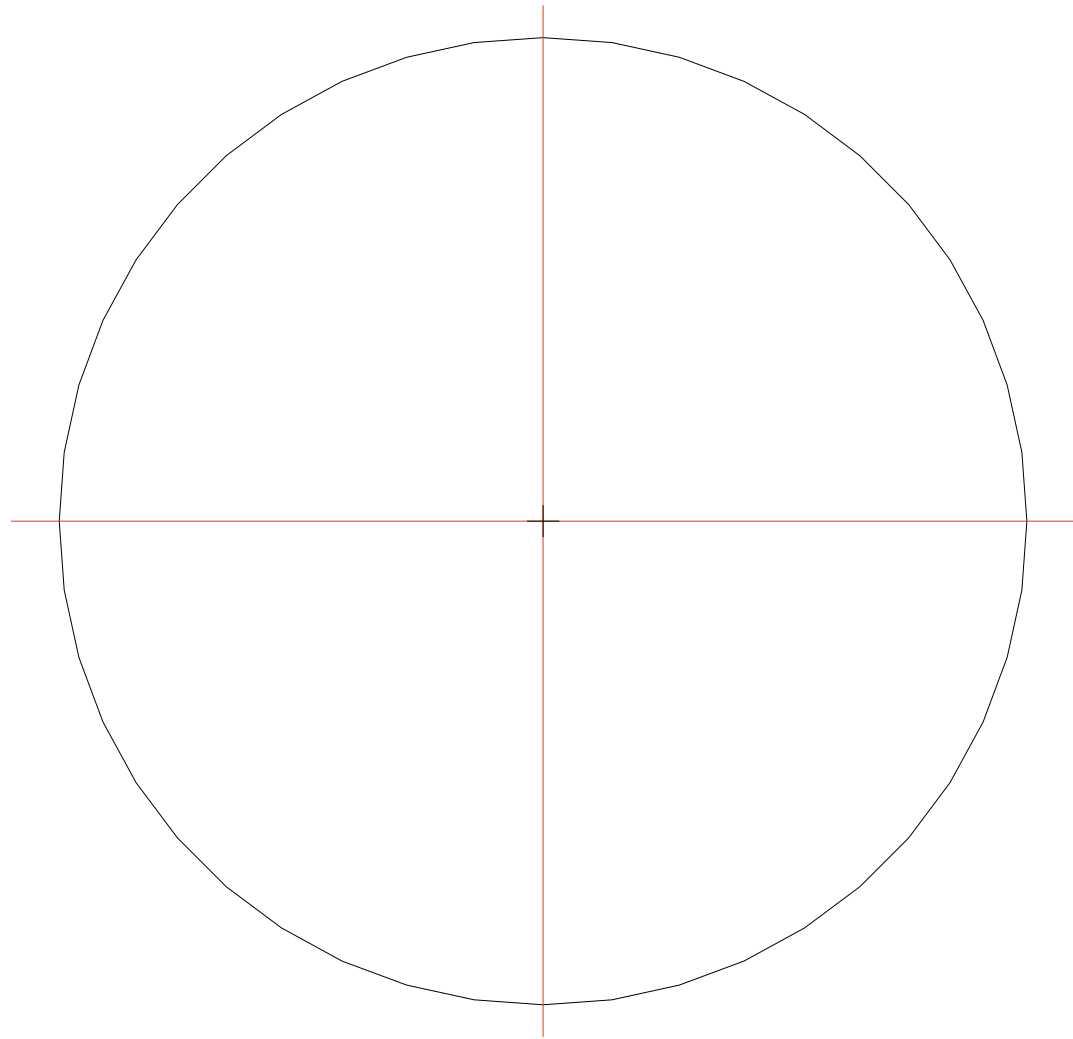

Graphic Construction Example 4

Given a circle of radius R , inscribe a hexagon inside the circle.

Draw two perpendicular diameters that pass through the centre of the circle. Select one of the diameters as the reference. Two of the sides of the hexagon will be perpendicular to the other diameter.

From the intersection of the reference diameter with the circle, draw two arcs of same opening as the circle to intersect the given circle in 4 points.

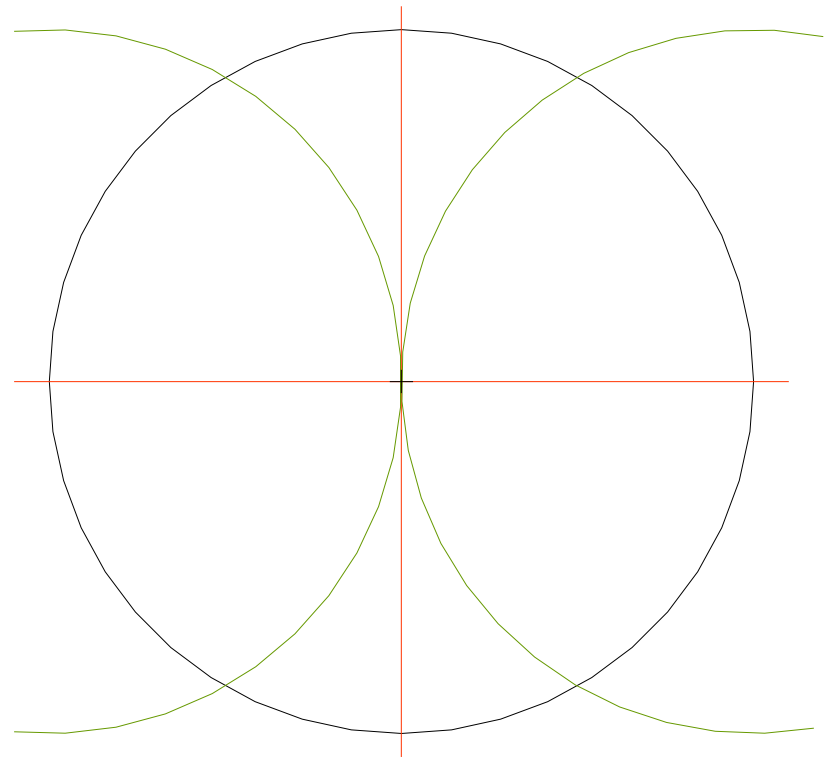

Graphic Construction Example 4

Given a circle of radius R , inscribe a hexagon inside the circle.

Draw two perpendicular diameters that pass through the centre of the circle. Select one of the diameters as the reference. Two of the sides of the hexagon will be perpendicular to the other diameter.

From the intersection of the reference diameter with the circle, draw two arcs of same opening as the circle to intersect the given circle in 4 points.

The four points of intersection and the two centre of the arcs will form the hexagon when connected in order.

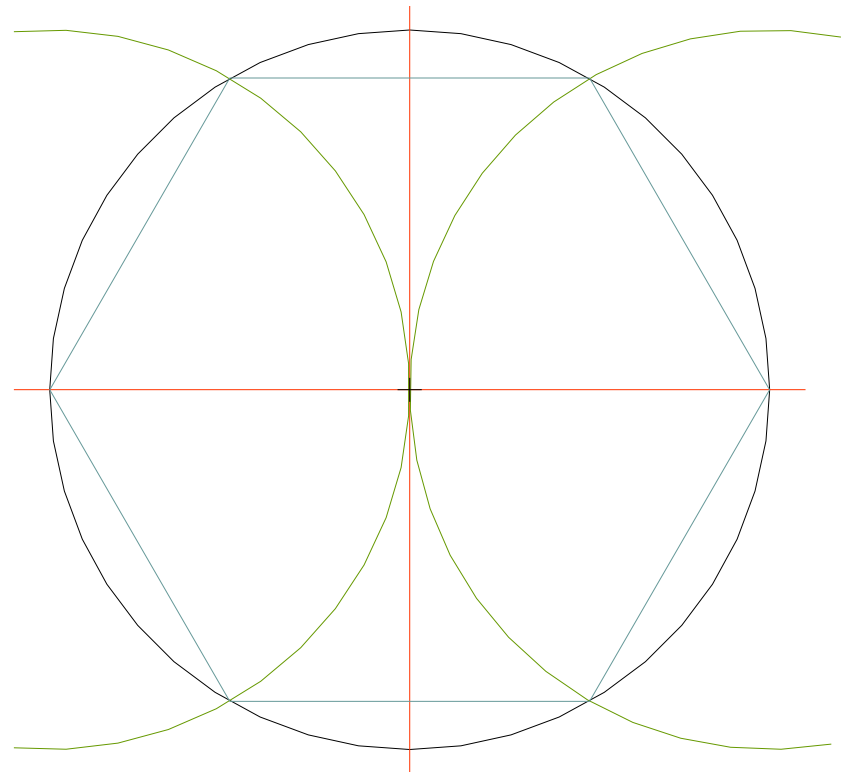

Graphic Construction Example 5

Given the
segment AB, find
the point D such
that the ratio
AD/BD is to be
5/6.



Graphic Construction Example 5

Given the segment AB, find the point D such that the ratio AD/BD to be $5/6$.

A ratio of $5/8$ requires a number of $5 + 6 = 11$ equal segments to be built. Draw a line of a convenient direction that passes through either point A or B, as is more convenient. The line should be long enough to accommodate 11 equal segments of an appropriate length.

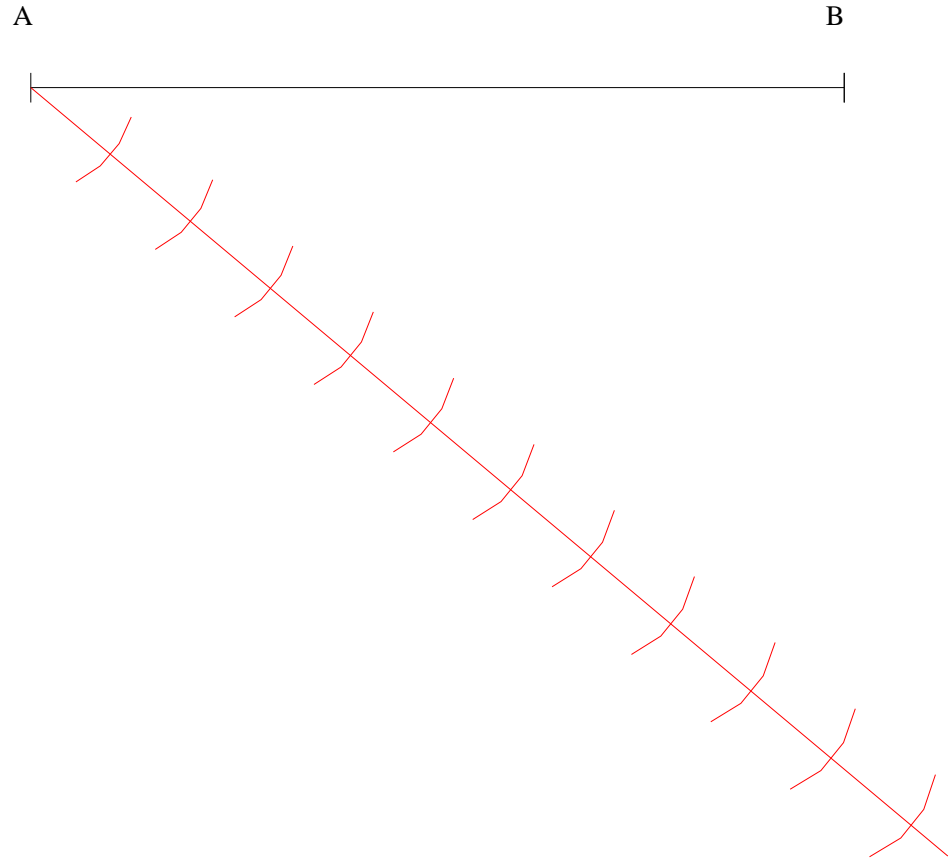

Graphic Construction Example 5

Given the segment AB, find the point D such that the ratio AD/BD to be $5/6$. A ratio of $5/8$ requires a number of $5 + 6 = 11$ equal segments to be built. Draw a line of a convenient direction that passes through either point A or B, as is more convenient.

The line should be long enough to accommodate 11 equal segments of a appropriate length.

Connect the end of the last drawn segment of the auxiliary line to the other end of the line. Draw parallel lines to the previously described line. The parallel lines will divide the segment AB is 11 equal segments.

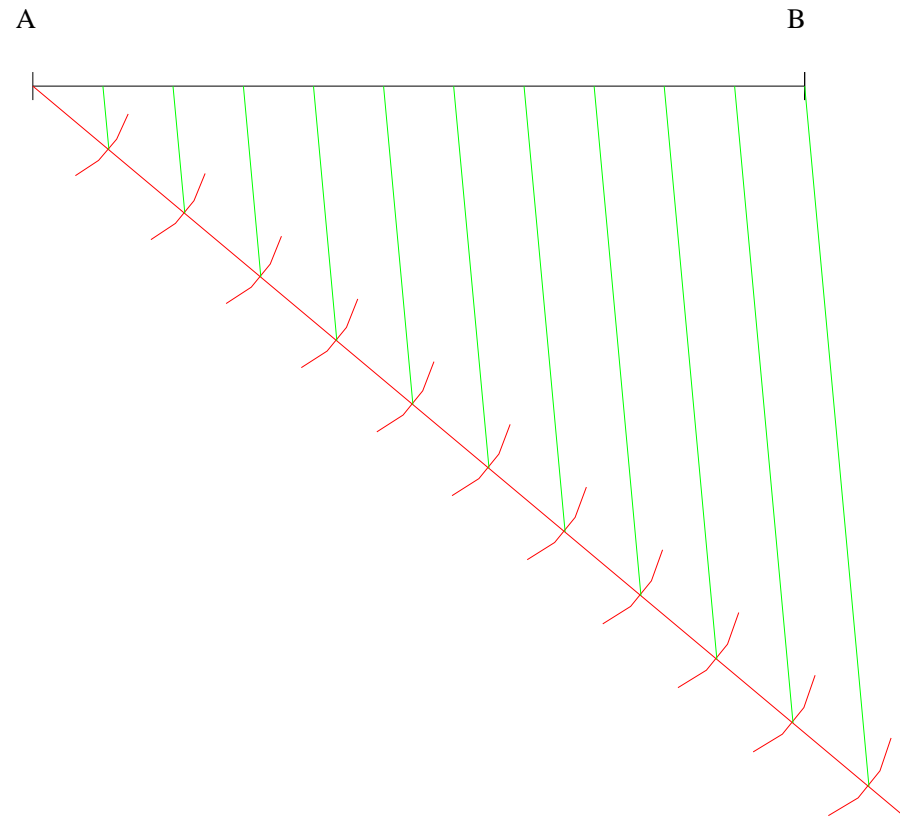

Graphic Construction Example 5

Given the segment AB, find the point D such that the ratio AD/BD to be $5/6$. A ratio of 5 requires a number of $5 + 6 = 11$ equal segments to be built. Draw a line of a convenient direction that passes through either point A or B, as is more convenient. The line should be long enough to accommodate 11 equal segments of an appropriate length.

Connect the end of the last drawn segment of the auxiliary line to the other end of the line. Draw parallel lines to the previously described line. The parallel lines will divide the segment AB is 11 equal segments.

Locate point D on the line AB such that $AD = 5$ segments while $BD = 6$ segments.

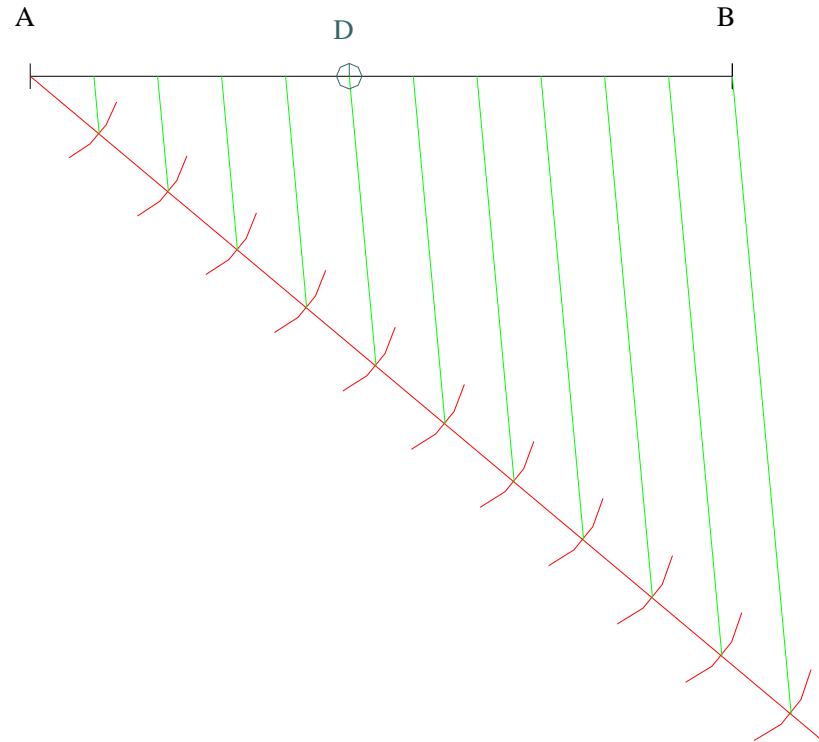

Laying out an angle

Laying Out An Angle. Sine Method.

Draw line X to any convenient length, preferably 100 units.

Find the sine of angle q in a table of natural sines, multiply by 100.

$$R = X \text{ SIN } \theta$$

$$\theta = 33^{\circ}16'$$

$$R = 100 \times \text{SIN } 33^{\circ}16'$$

$$R = 100 \times 0.5485364$$

$$R = 54.85364$$



Laying out an angle

Laying Out An Angle. Sine Method.

Draw line X to any convenient length, preferably 100 units.

Find the sine of angle q in a table of natural sines, multiply by 100, and strike arc R = 54.85364

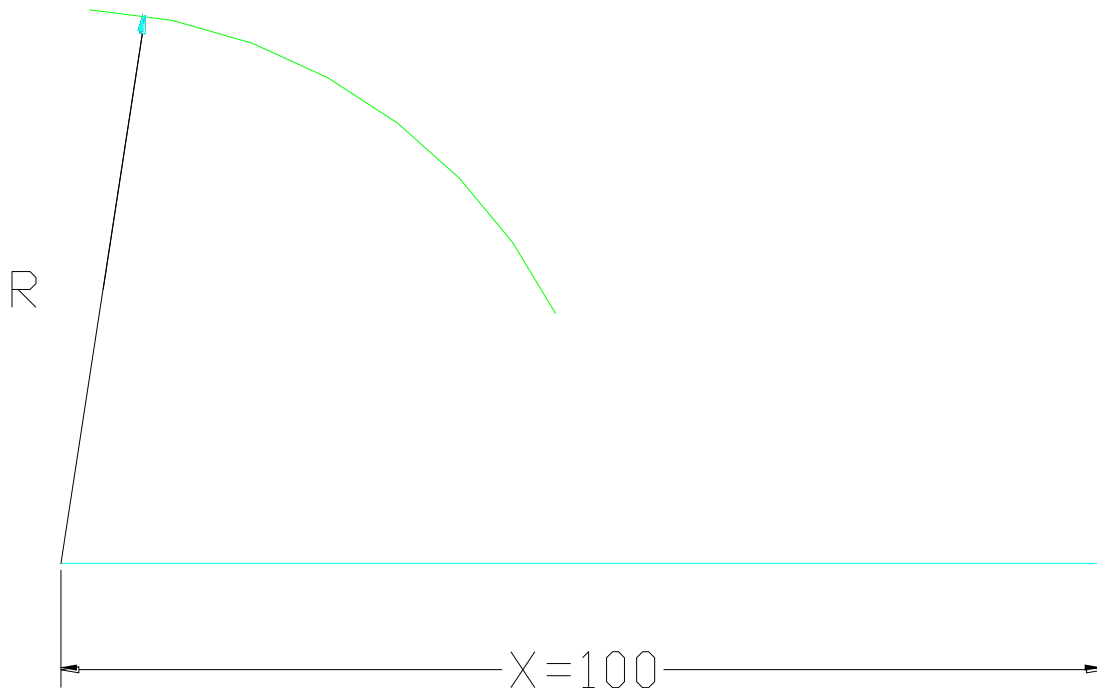

$$R = X \sin \theta$$

$$\theta = 33^\circ 16'$$

$$R = 100 \times \sin 33^\circ 16'$$

$$R = 100 \times 0.5485364$$

$$R = 54.85364$$

Laying out an angle

Laying Out An Angle, Sine Method.

Draw line X to any convenient length, preferably 100 units.

Find the sine of angle q in a table of natural sines, multiply by 100, and strike arc $R=100\text{SIN}q$.

Draw the other side of the angle tangent to the arc.

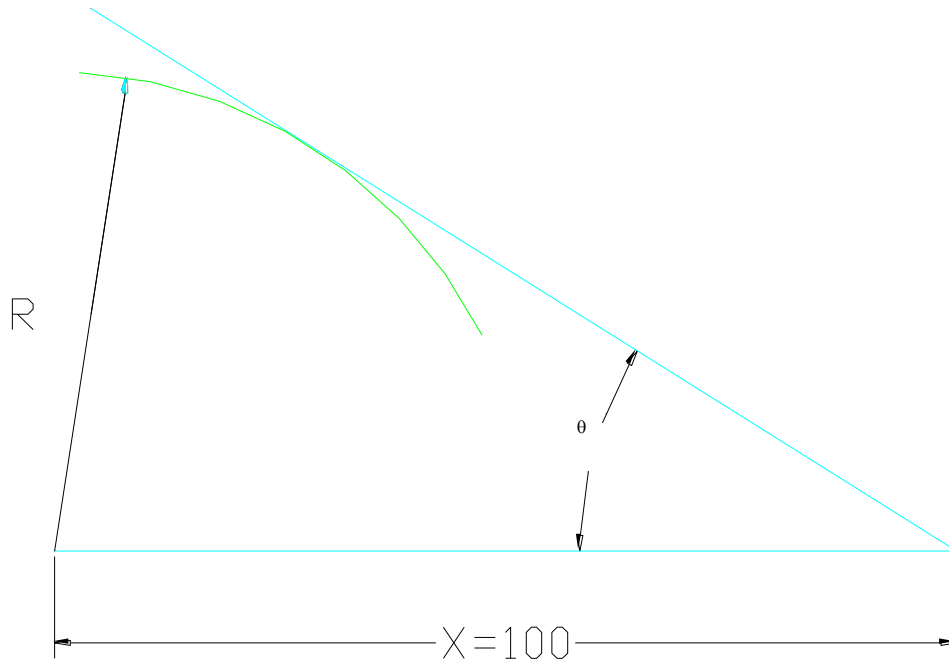

$$R = X \text{SIN } \theta$$

$$\theta = 33^{\circ}16'$$

$$R = 100 \times \text{SIN } 33^{\circ}16'$$

$$R = 100 \times 0.5485364$$

$$R = 54.85364$$

Transfer a Triangle

Transferring a Triangle to a New Location.

Set off any side of the given triangle, such as ABC, in the new location. Start from the selected location of the point of choice.

Draw an arc (red) with the center in A of radius AB.

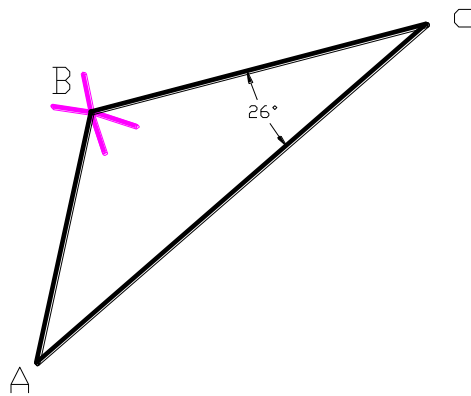

(a)

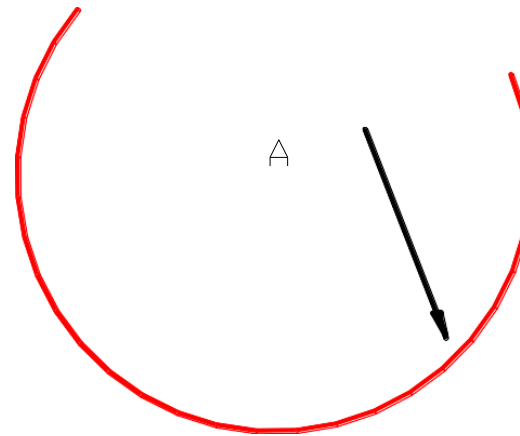

(b)

Transfer a Triangle

Transferring a Triangle to a New Location.

From A draw a line of the specified direction until intersects the arc.

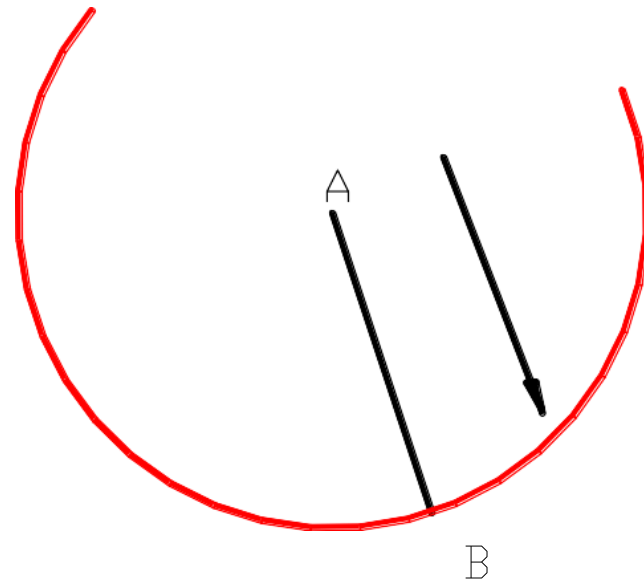
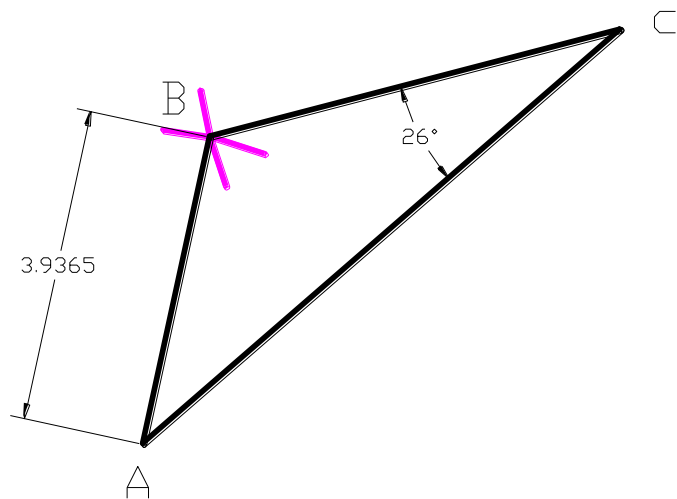

Transfer a Triangle

From that point B, draw an arc (blue) with the centre in B of radius BC.

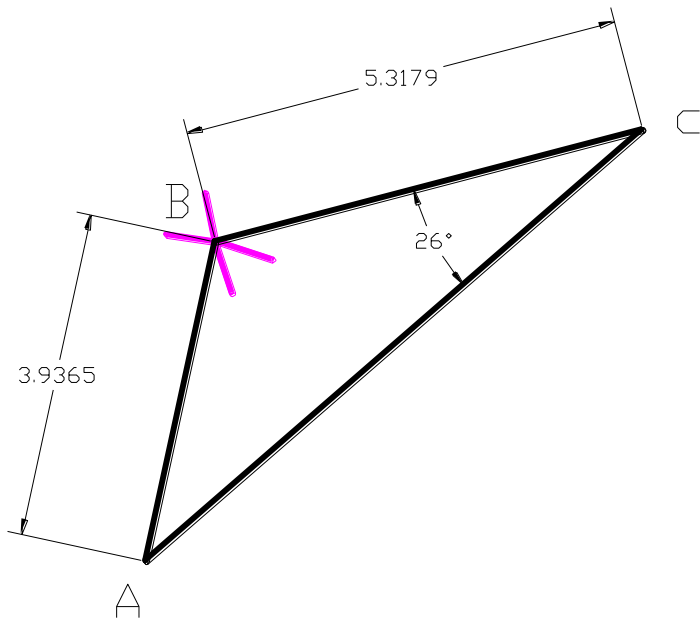

(a)

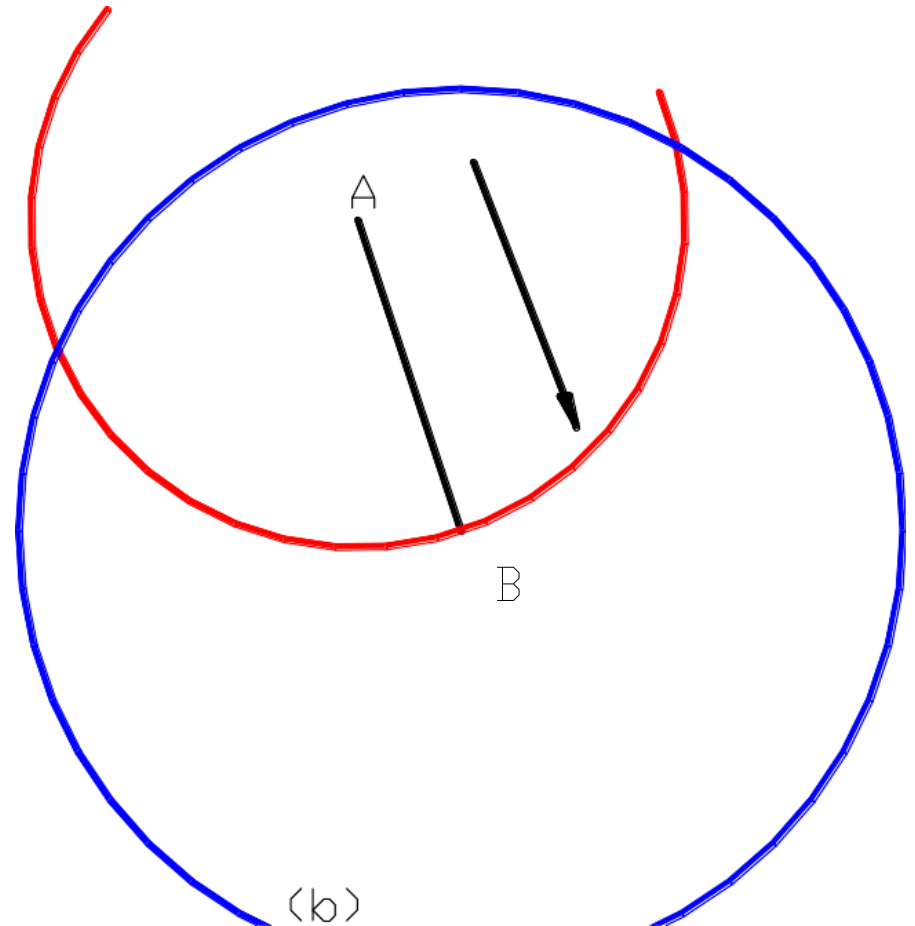

(b)

Transfer a Triangle

From A point, draw an arc (green) with the center in A and the radius AC.

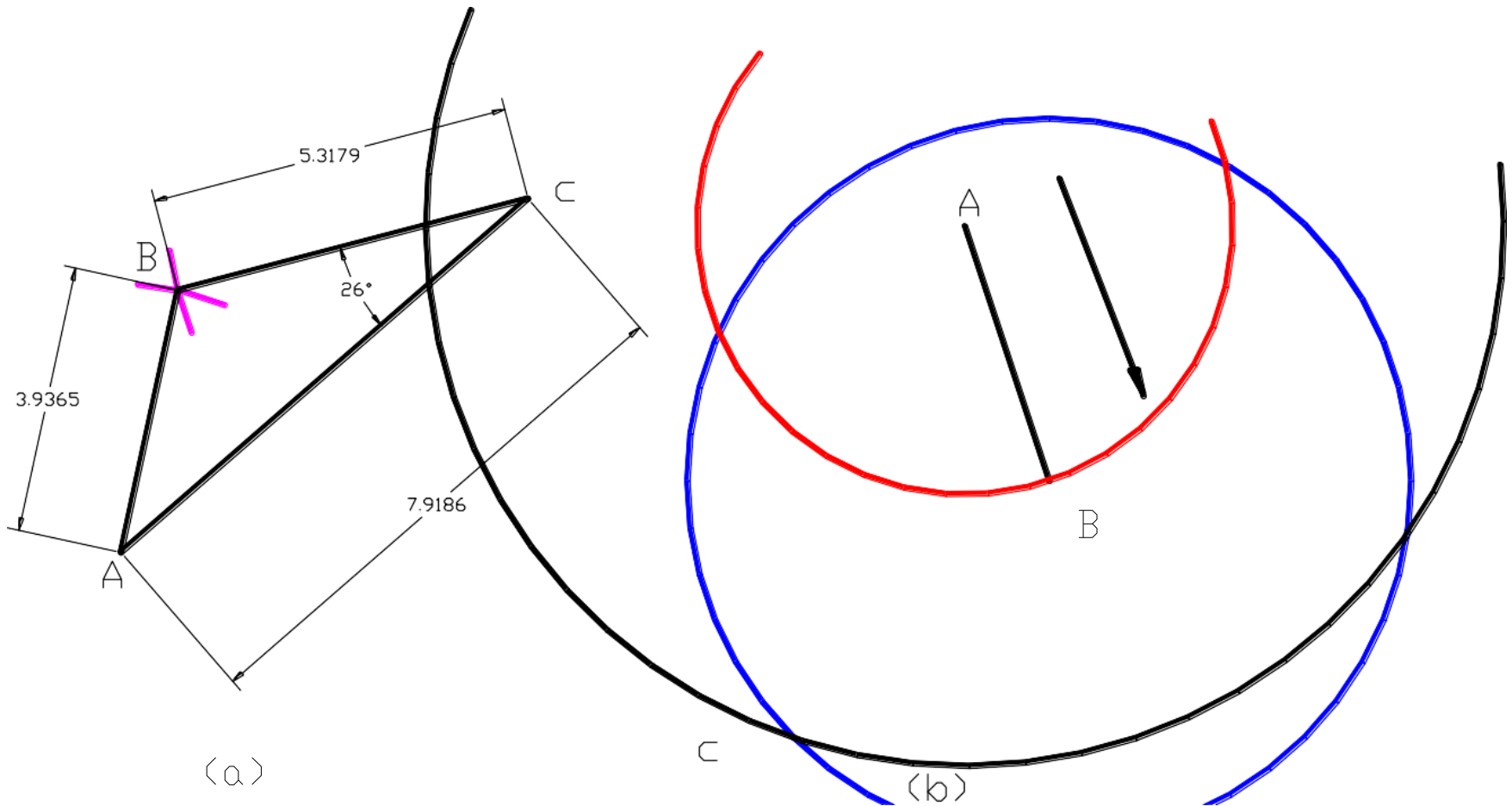

Transfer a Triangle

Connect B with C and again C with A. The triangle is relocated.

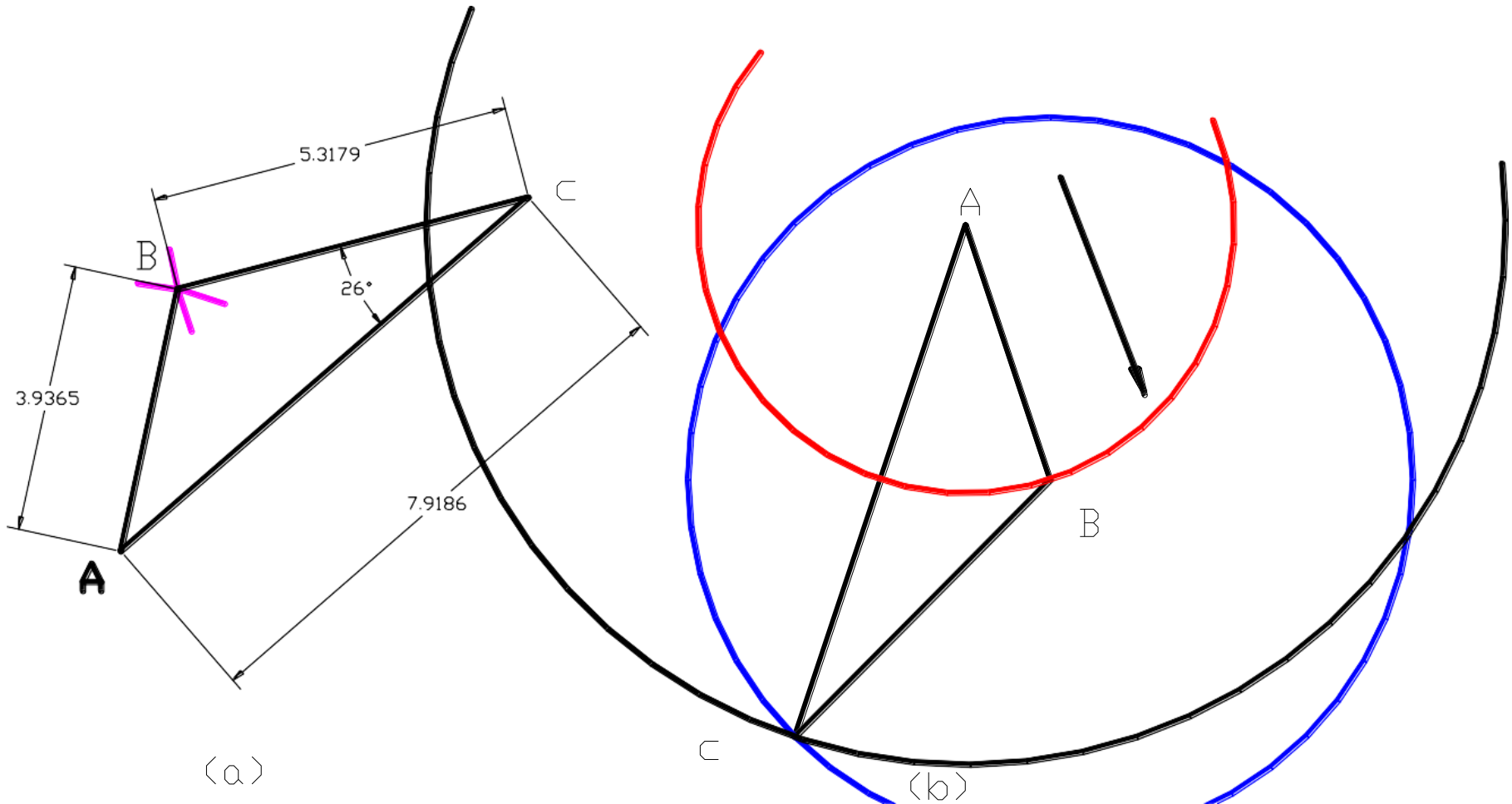

Draw an Arc Tangent to Two Arcs

To Draw a Circular Arc of a Given Radius R Tangent to Two Given Circular Arcs.

Given the circular arcs with centers A and B , and radius R and r , respectively.

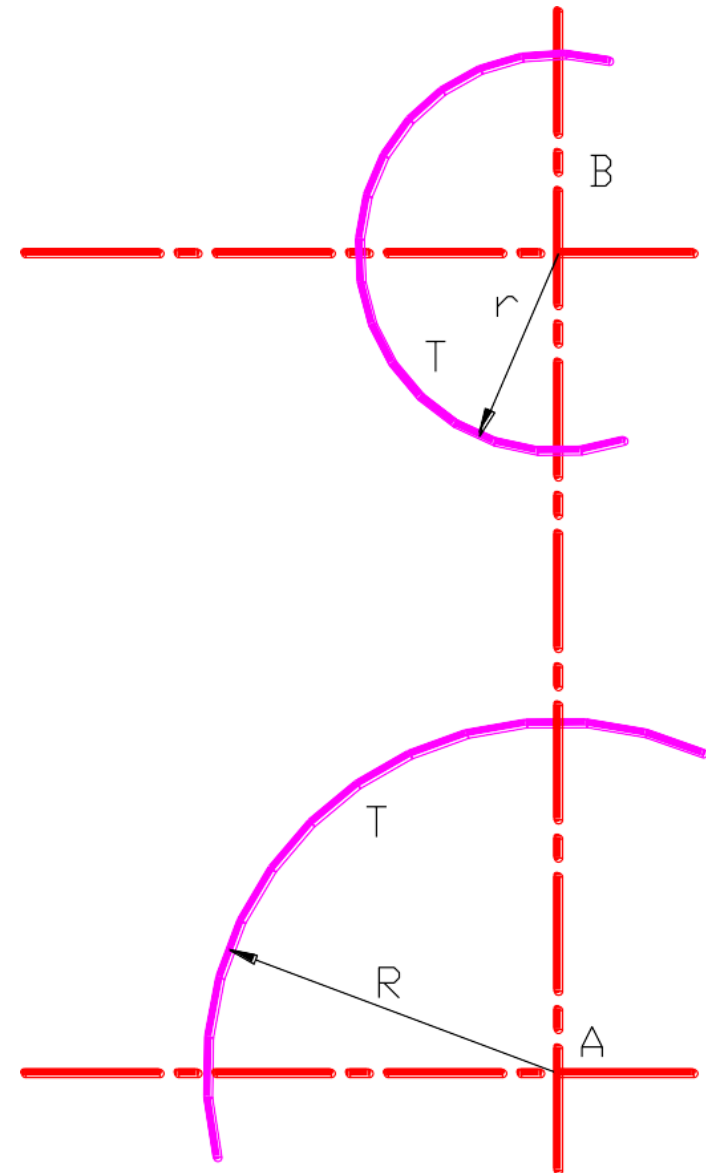

Draw an Arc Tangent to Two Arcs

To Draw a Circular Arc of a Given Radius R Tangent to Two Given Circular Arcs.

Given the circular arcs with centers A and B , and radius R and r , respectively.

Using A as a center and R_1 plus R as a radius, strike an arc parallel to the first arc. Using B as a center and R_1 plus r as a radius, strike an intersecting arc parallel to second arc.

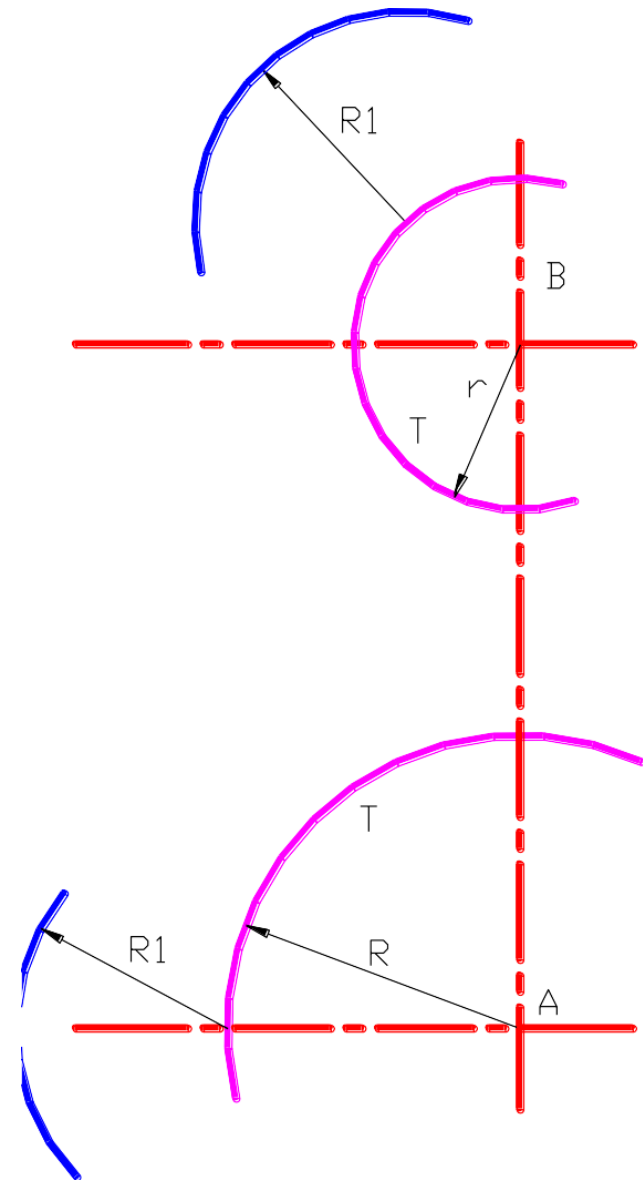

Draw an Arc Tangent to Two Arcs

To Draw a Circular Arc of a Given Radius R Tangent to Two Given Circular Arcs.

Given the circular arcs with centers A and B , and radius R and r , respectively.

Using A as a center and R_1 plus R as a radius, strike an arc parallel to the first arc. Using B as a center and R_1 plus r as a radius, strike an intersecting arc parallel to second arc.

Because each of these intersecting arcs are distance R_1 , away from arcs, C will be the center for the required arc that is tangent to both.

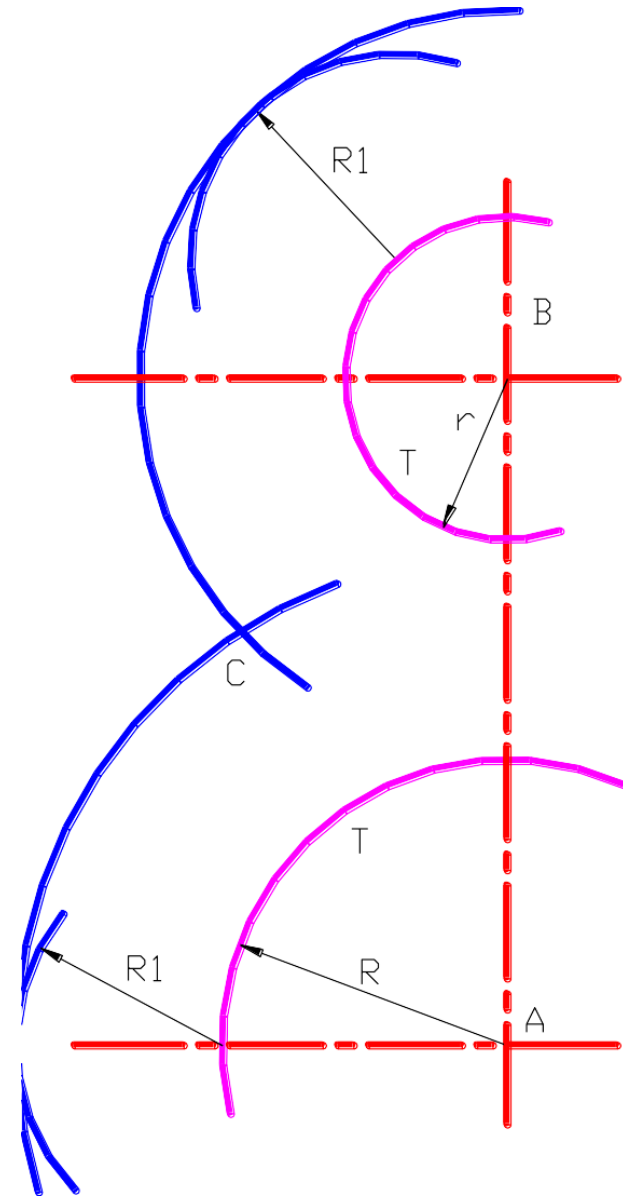

Draw an Arc Tangent to Two Arcs

To Draw a Circular Arc of a Given Radius R Tangent to Two Given Circular Arcs.

Mark the points of tangency T and T that lie on the lines of centers AC and BC .

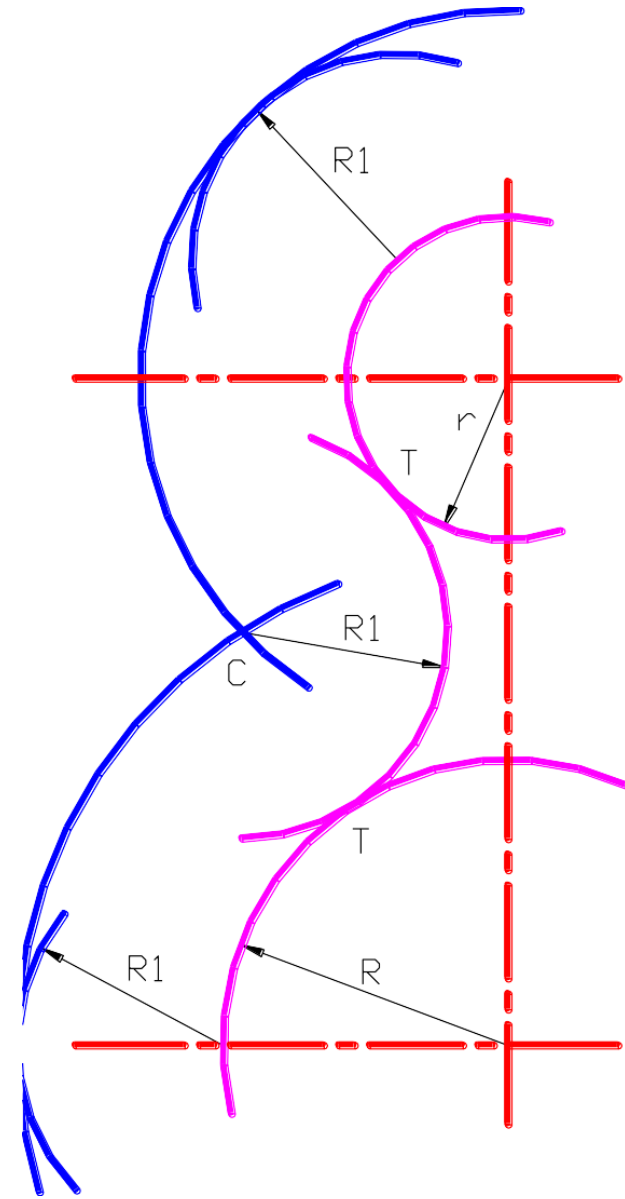

Draw an Arc Tangent to Two Lines

Draw a Circular Arc of Radius R Tangent to Two Lines.

Given the two lines, not at right angles, and the radius R . Draw a Circular Arc of Radius R Tangent to Two Lines.

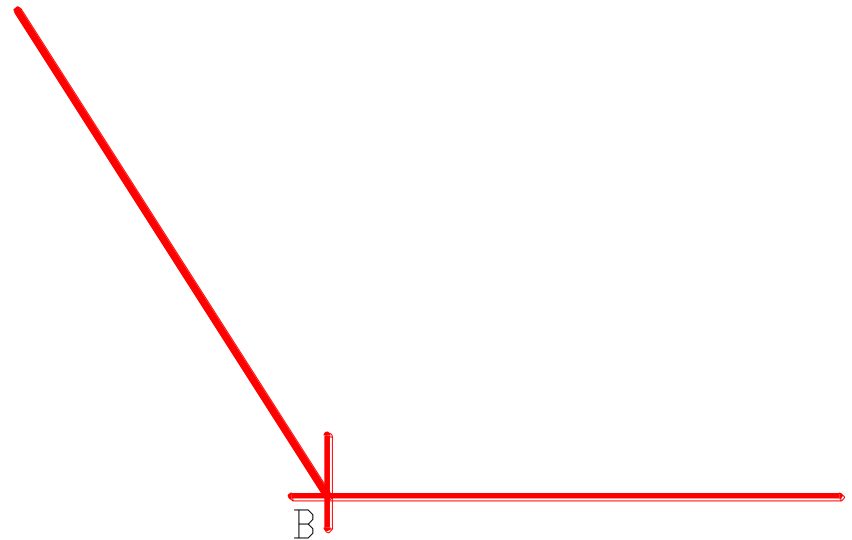
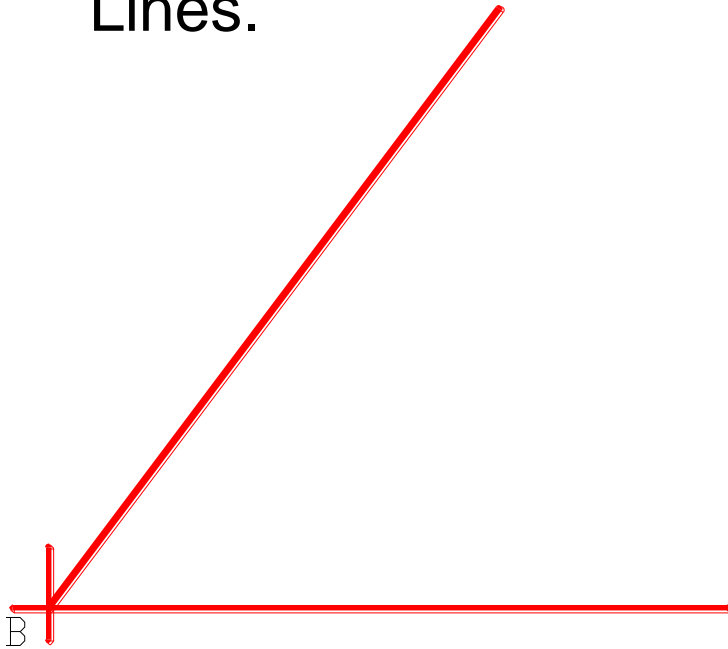

Draw an Arc Tangent to Two Lines

Draw a Circular Arc of Radius R Tangent to Two Lines.

Given the two lines, not at right angles, and the radius R . Draw lines parallel to the given lines at a distance R . Because the point of intersection of these lines is distance R from both given lines, it will be the center C of the required arc.

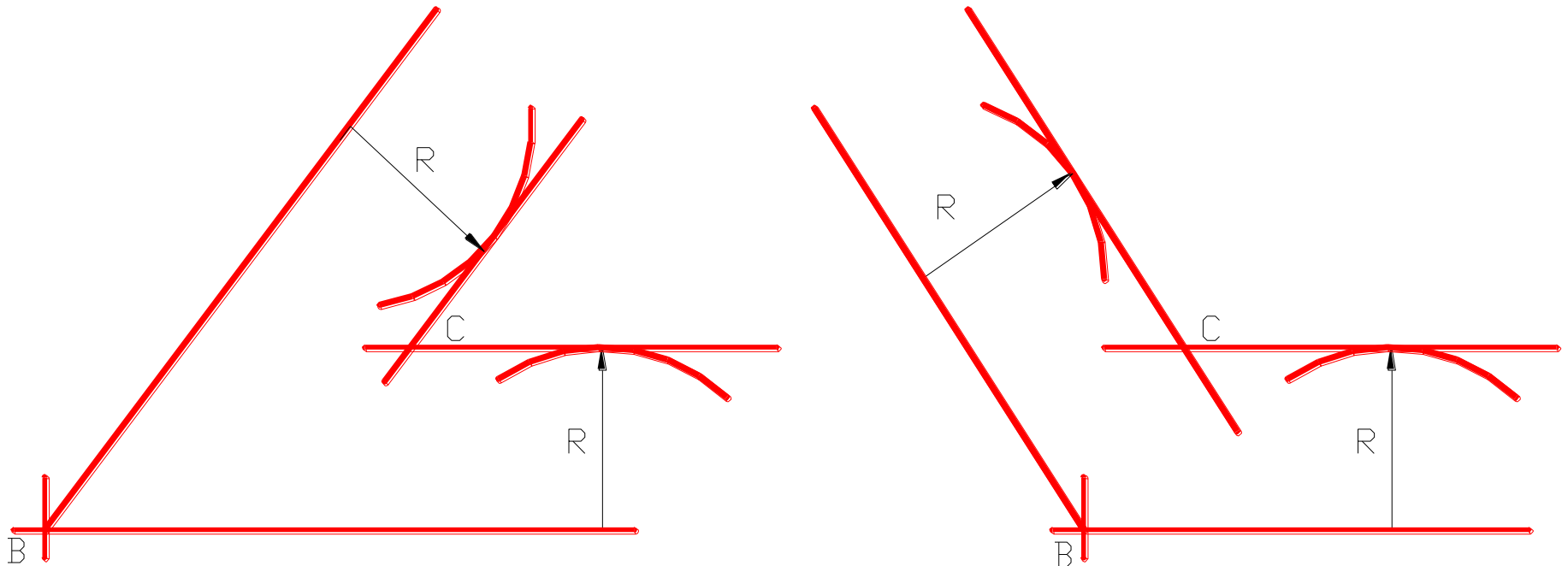

Draw an Arc Tangent to Two Lines

Draw a Circular Arc of Radius R Tangent to Two Lines.

Given the two lines, not at right angles, and the radius R . Draw lines parallel to the given lines at a distance R . Because the point of intersection of these lines is distance R from both given lines, it will be the center C of the required arc.

Draw the arc of radius R .

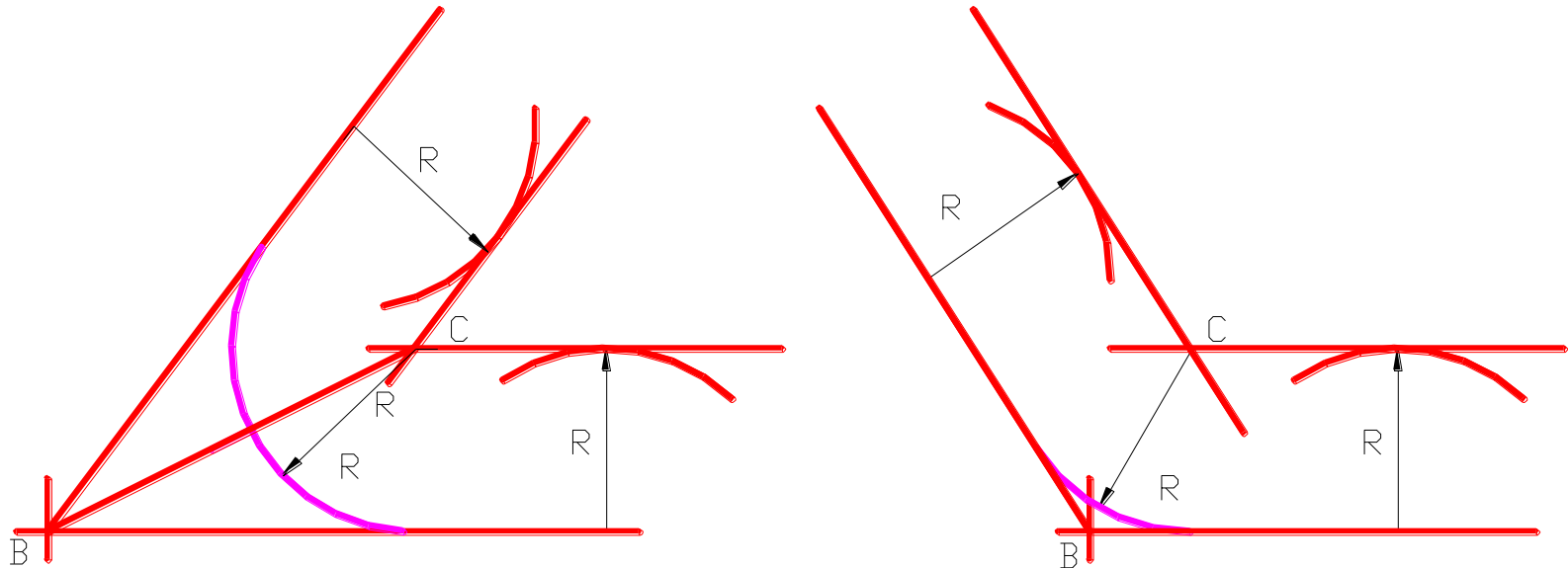

Draw an Arc Tangent to Two Lines

Draw a Circular Arc of Radius R Tangent to Two Lines.

Mark the tangent points $T1$ and $T2$ are found at the intersection of the perpendiculars from C to the sides of the angle.

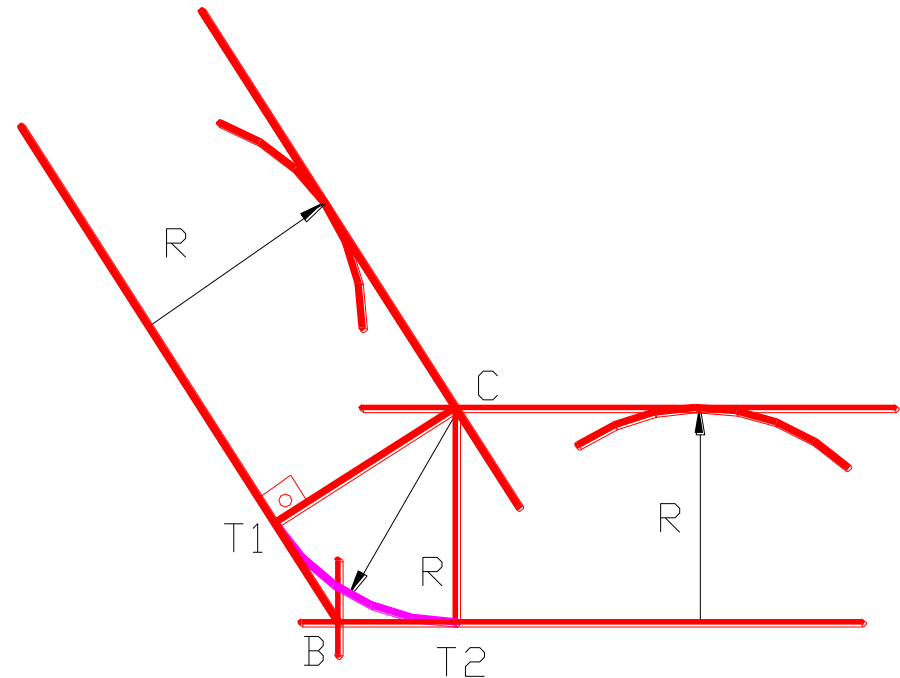
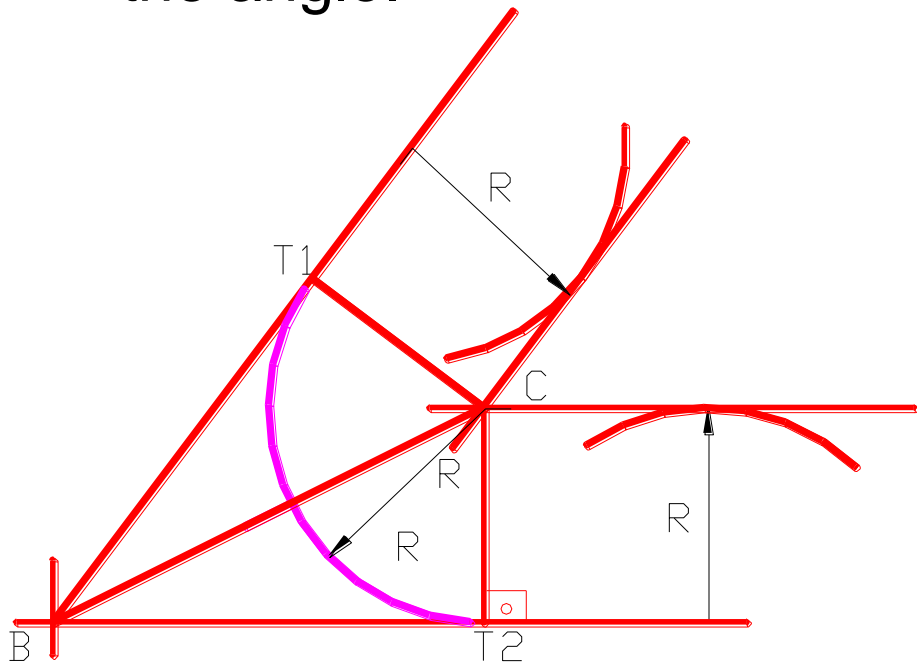

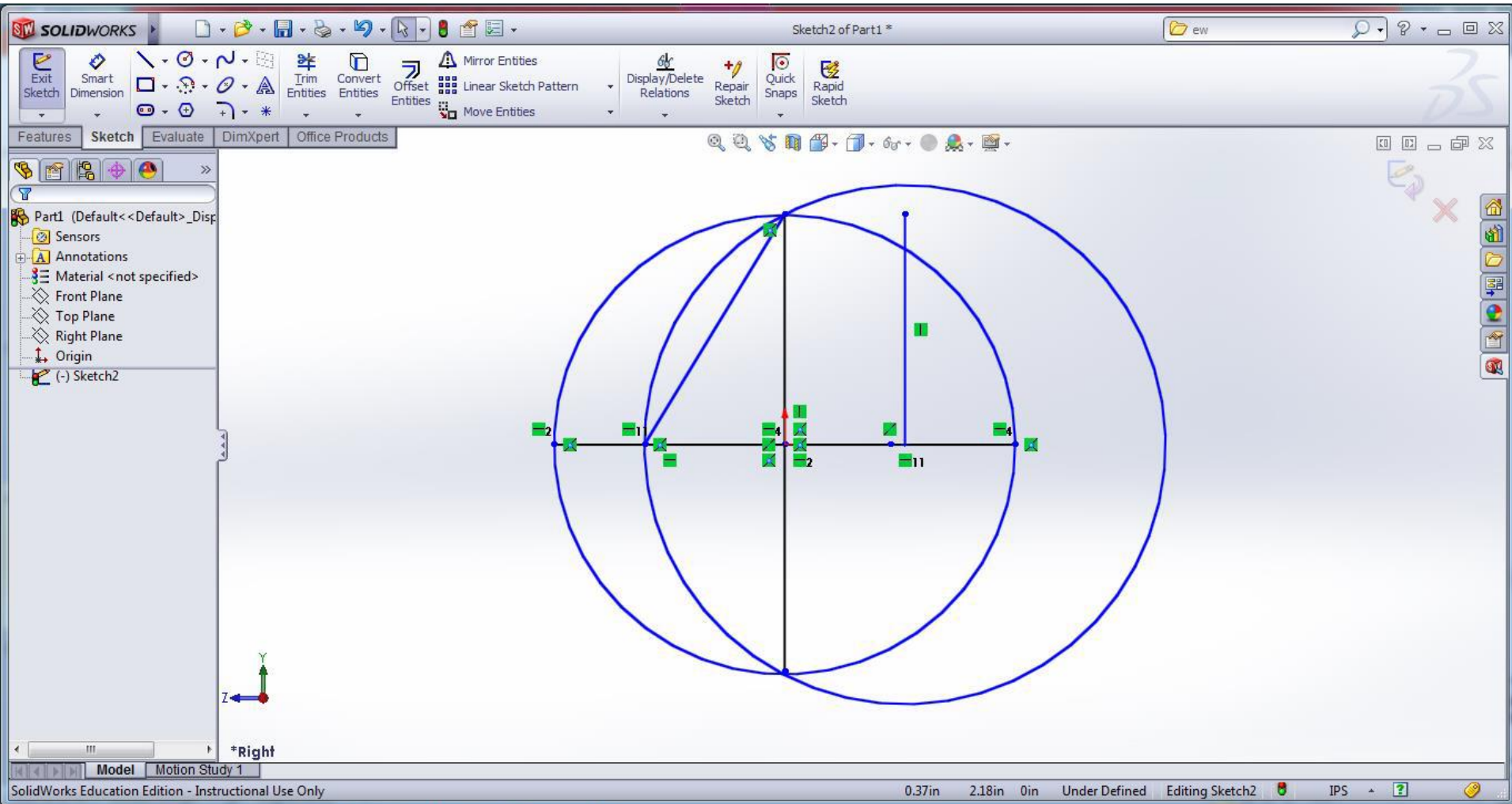

Computer Assisted Design

ADVANTAGES

- Create a traceable record in the documentation
- Integration of analysis, manufacturing, cost analysis
- Solid modeling - assembly and interference analysis
- Easy portable and shareable documentation

DISADVANTAGES

- More effort in design
- No more drafting personnel (?)

Computer Assisted Design

Types of CAD tools

- Comprehensive – with integrated modules for stress analysis, thermal analysis – etc. (Ex: CATIA, Pro ENGINEER, IDEAS)
- Drafting – low end CAD tools (AutoCAD)

Cost is proportional to the capability of the tool

- 85% of companies use low end CAD tools

INTRODUCTION TO AUTOCAD

**COMPUTER ASSISTED
DESIGN**



CAD Software

Used to facilitate design

- Better quality drawings (accuracy 10-14 of a unit)
- Easier to operate modifications
- Convenient archiving
- Structured organization of the documentation
- Portability and exchange
- Synergy
- Integrated approach on design, analysis, optimization, etc.

CAD Software

Disadvantages:

- Requires special training.
- Difficult to be used in the preliminary ideation process (free hand sketching).
- Requires expensive software and computing equipment.
- If not used to the entire capability, such CAD tools are more liability than advantage.

AutoCAD

Basic introduction to AutoCAD

- Used by many small industries
 - cost-based decision
 - Practicability-based decision
- Requires other pieces of software to be able to integrate the design with the analysis

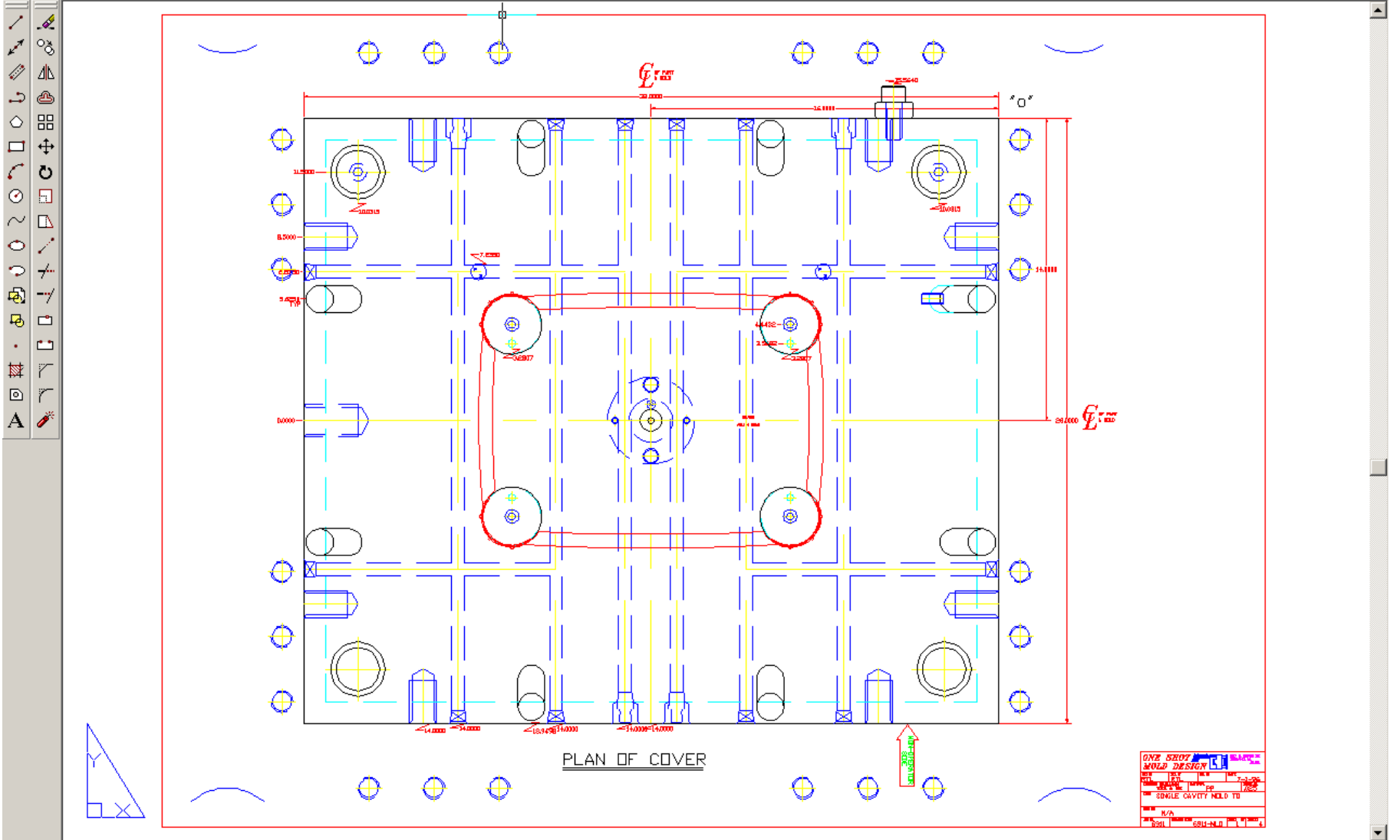

ZOOM
Specify corner of window, enter a scale factor (nX or nXP), or
[All/Center/Dynamic/Extents/Previous/Scale/Window] <real time>: w
Specify first corner: Specify opposite corner:
Command:

- New... Ctrl+N
- Open... Ctrl+O
- Close
- Partial Load
- Save Ctrl+S
- Save As...
- eTransmit...
- Publish to Web...
- Export...
- Page Setup...
- Plotter Manager...
- Plot Style Manager...
- Plot Preview
- Plot... Ctrl+P
- Drawing Utilities >
- Send...
- Drawing Properties...
- 1 Drawing15.dwg
- 2 F:\Drive_F\...\Prob.28.dwg.dwg
- 3 F:\Drive_F\...\Prob.31.dwg.dwg
- 4 F:\Drive_F\...\Prob.09.dwg.dwg
- Exit

ByLayer ByLayer ByLayer ByColor

Standard

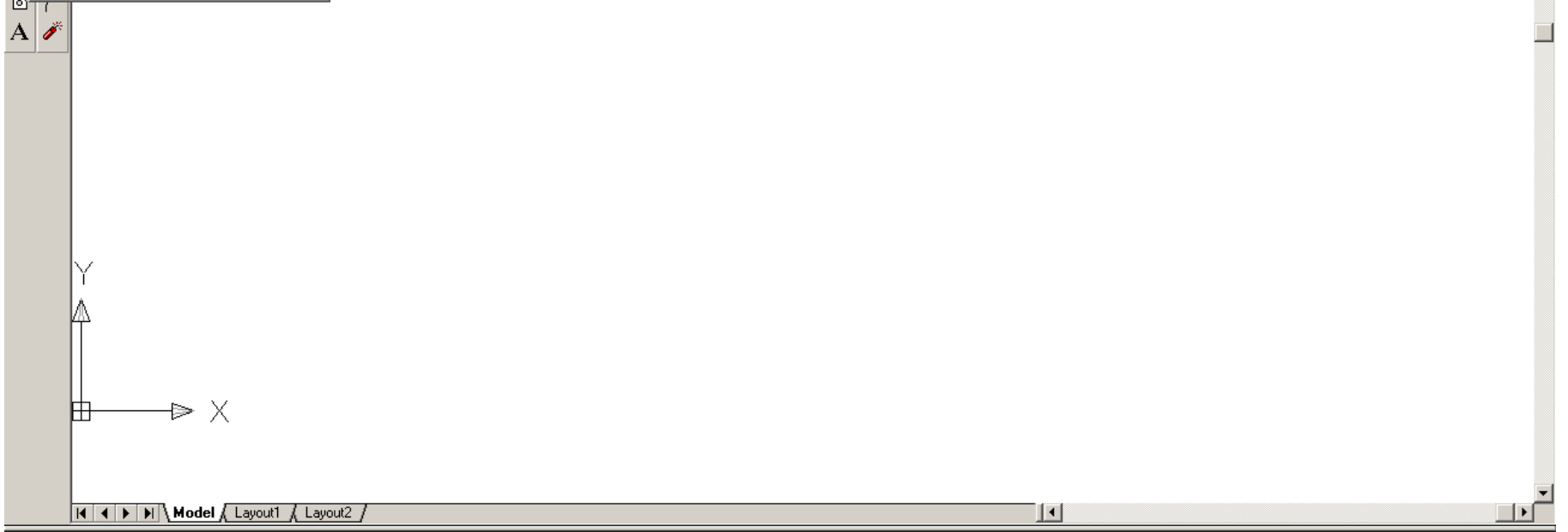

C:\Program Files\Ansys Inc\CAD Integration\Mechanical Desktop\MD4PlugInU.arx
cannot find a dll or other file that it needs.
AutoCAD menu utilities loaded.
Command:
Command:

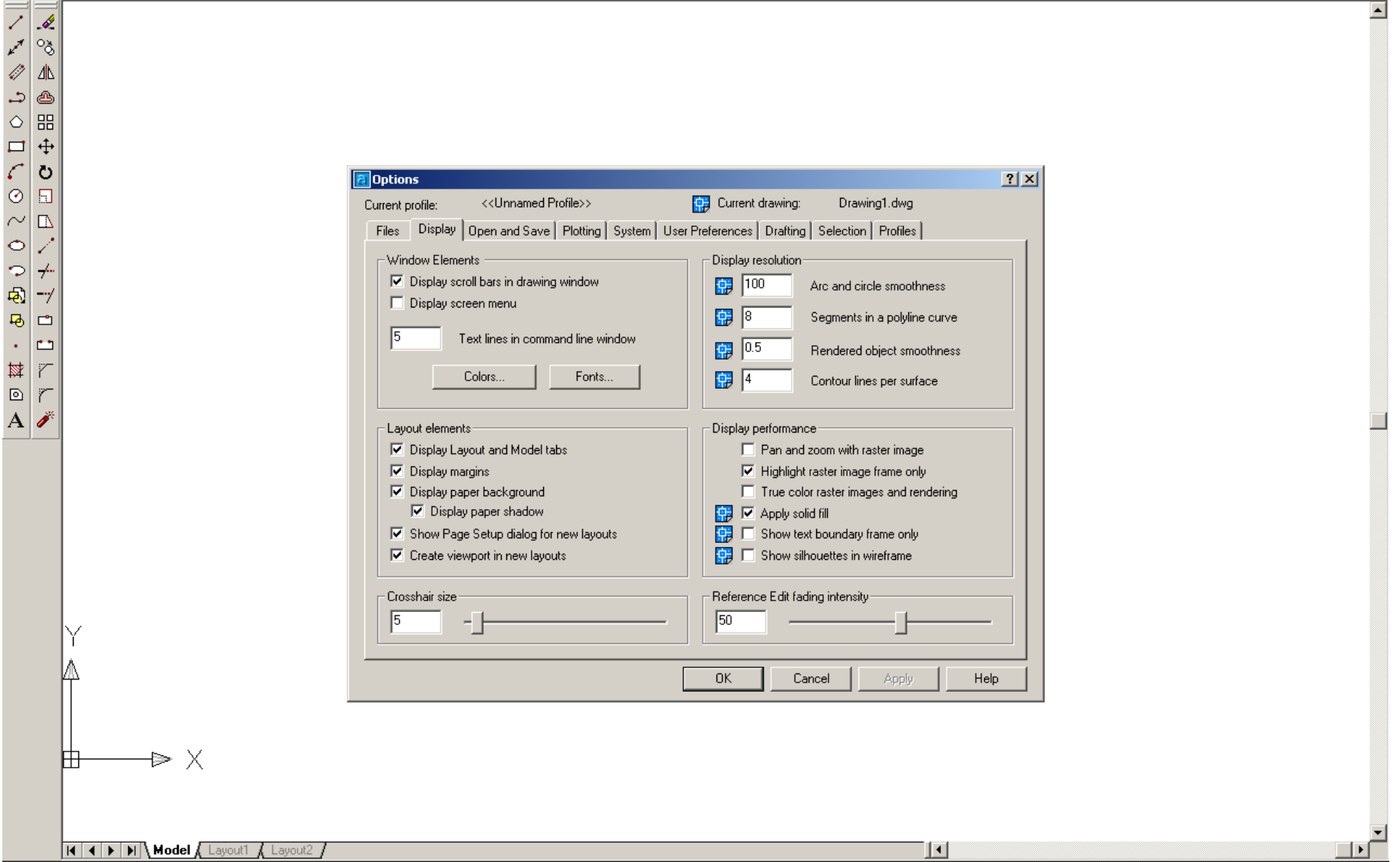
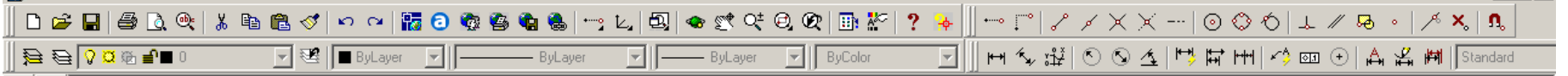

Options [?] [X]

Current profile: <<Unnamed Profile>> Current drawing: Drawing1.dwg

Files | Display | Open and Save | Plotting | System | User Preferences | Drafting | Selection | Profiles

Window Elements

- Display scroll bars in drawing window
- Display screen menu
- 5 Text lines in command line window
- Colors...
- Fonts...

Display resolution

- 100 Arc and circle smoothness
- 8 Segments in a polyline curve
- 0.5 Rendered object smoothness
- 4 Contour lines per surface

Layout elements

- Display Layout and Model tabs
- Display margins
- Display paper background
 - Display paper shadow
- Show Page Setup dialog for new layouts
- Create viewport in new layouts

Display performance

- Pan and zoom with raster image
- Highlight raster image frame only
- True color raster images and rendering
- Apply solid fill
- Show text boundary frame only
- Show silhouettes in wireframe

Crosshair size

5 [Slider]

Reference Edit fading intensity

50 [Slider]

OK Cancel Apply Help

AutoCAD menu utilities loaded.
 Command:
 Command:
 Command:

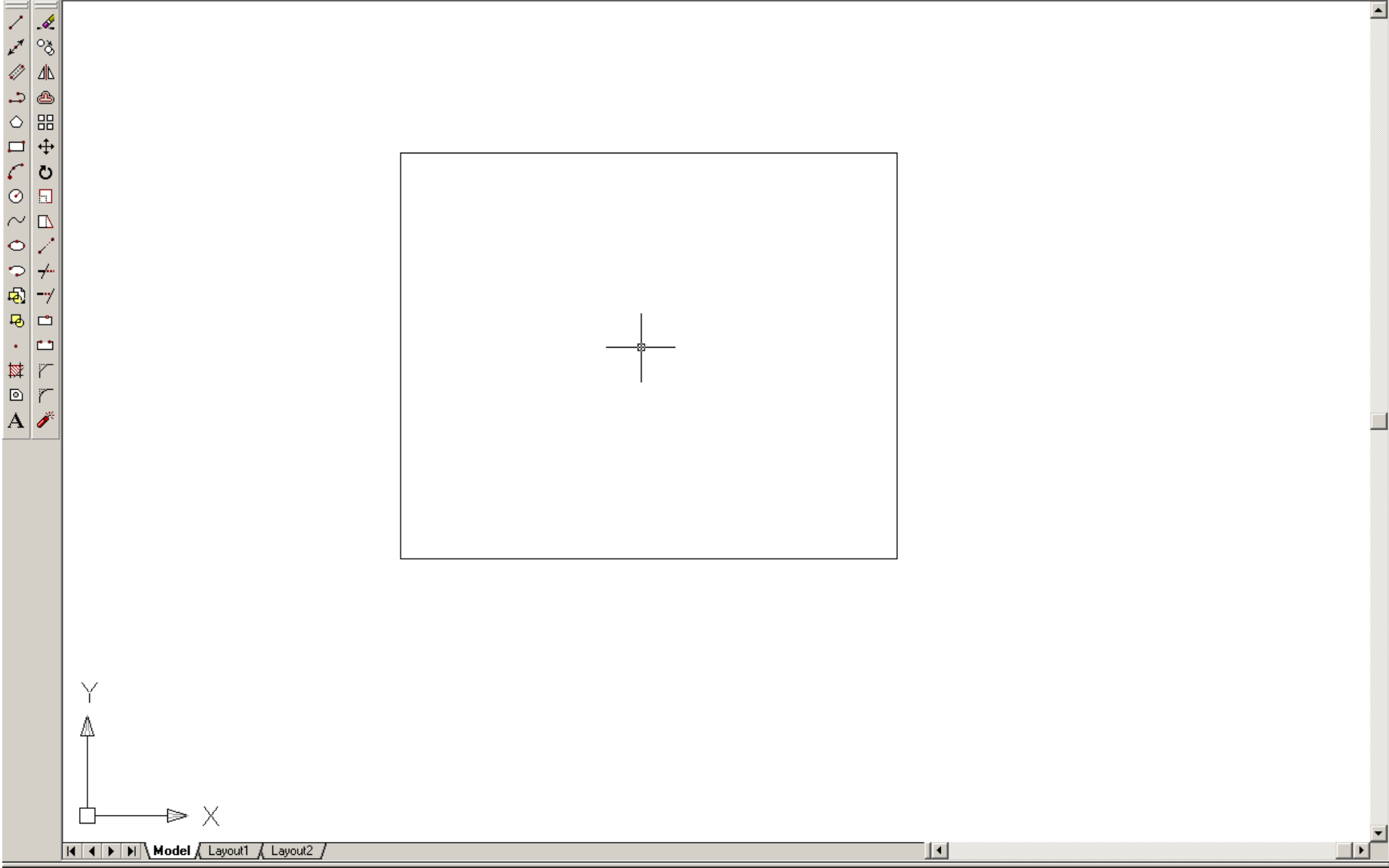
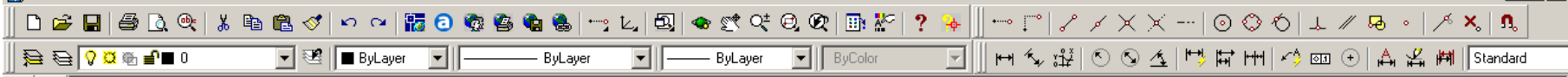

Command:
Command: _rectang
Specify first corner point or [Chamfer/Elevation/Fillet/Thickness/Width]:
Specify other corner point or [Dimensions]:
Command:

Begin AutoCAD

AUTOCAD DEMO



http://www.ugs.com/products/open/d-cubed/animations/aem/product_animation_geneva.htm

