

MECH 211 – Mechanical Engineering Drawing

François Tardy

Credits: 3.5

Lecture 4

Content of the lecture

1. Point – location, particular positions (on the principal planes)
 2. Multiple points – lines
 3. Location of a line – the basic views
 4. Particular positions of a line – horizontal, frontal or profile
 5. True length of a line – selected auxiliary views
- 

Content of the lecture

6. Bearing of a line (in the top view, N(S) nn E(W))
7. Slope of a line (from the top view, draw a TL in aux view – elevation view)
8. Point view of a line – second aux. view
9. Relative position of a point vs. a line (location of a point vs. a line)
10. Relative position of two lines ($//$, \times or skew)
11. Parallel lines; rule of parallel lines (exceptions)

Content of the lecture

12. Location of a line through a point parallel to another line (construction)
 13. True distance between two parallel lines
 14. Intersecting lines – identification through inspection
 15. Perpendicular lines – rule of perpendicular lines
 16. Distance from a point to a line
 17. Location of a perpendicular line at a given point on a line
- 

1. Point - location

Representing a single point in space:

- Three views are needed: H, F, and P.
- Look for the distance between points and the folding line in adjacent views.

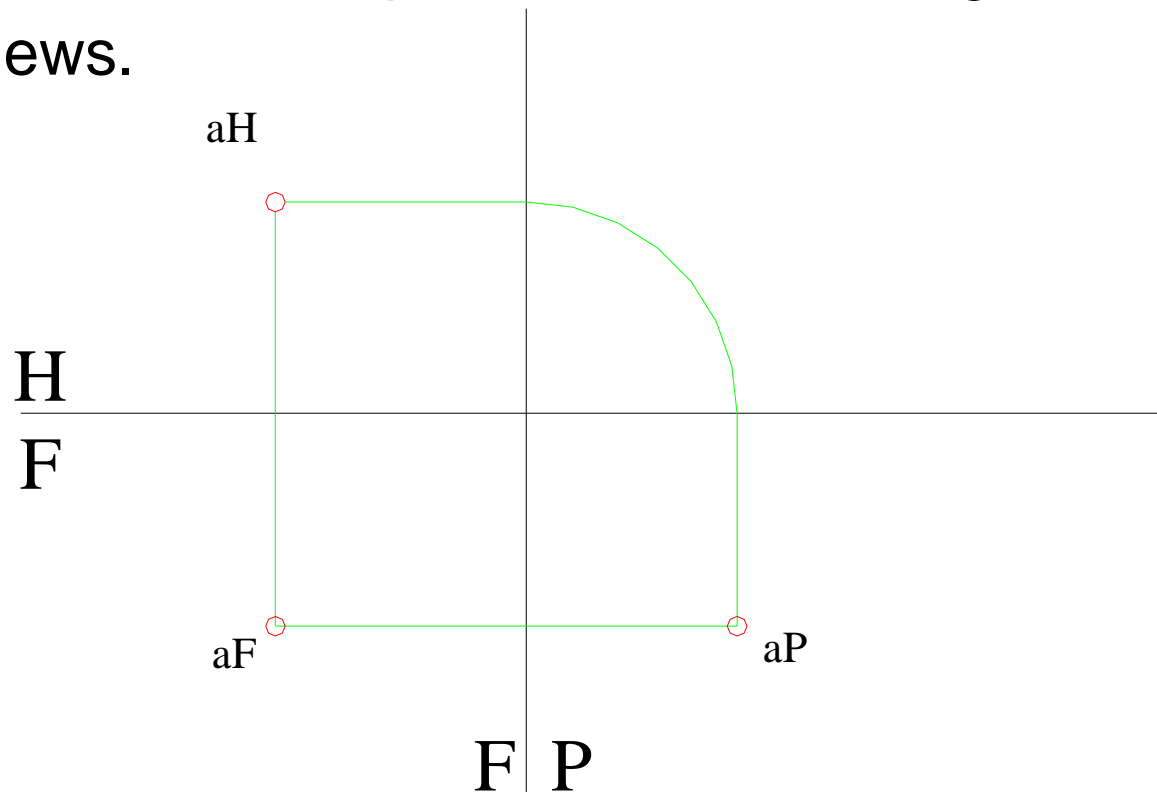
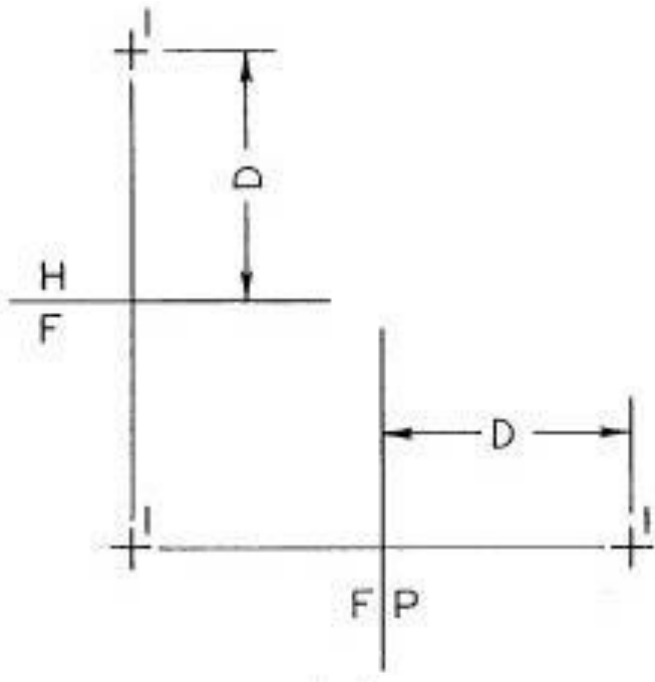

2. Multiple points - lines

Representing multiple points in space:

- Three views: H, F, and P.
- Locating multiple points is needed to define lines.

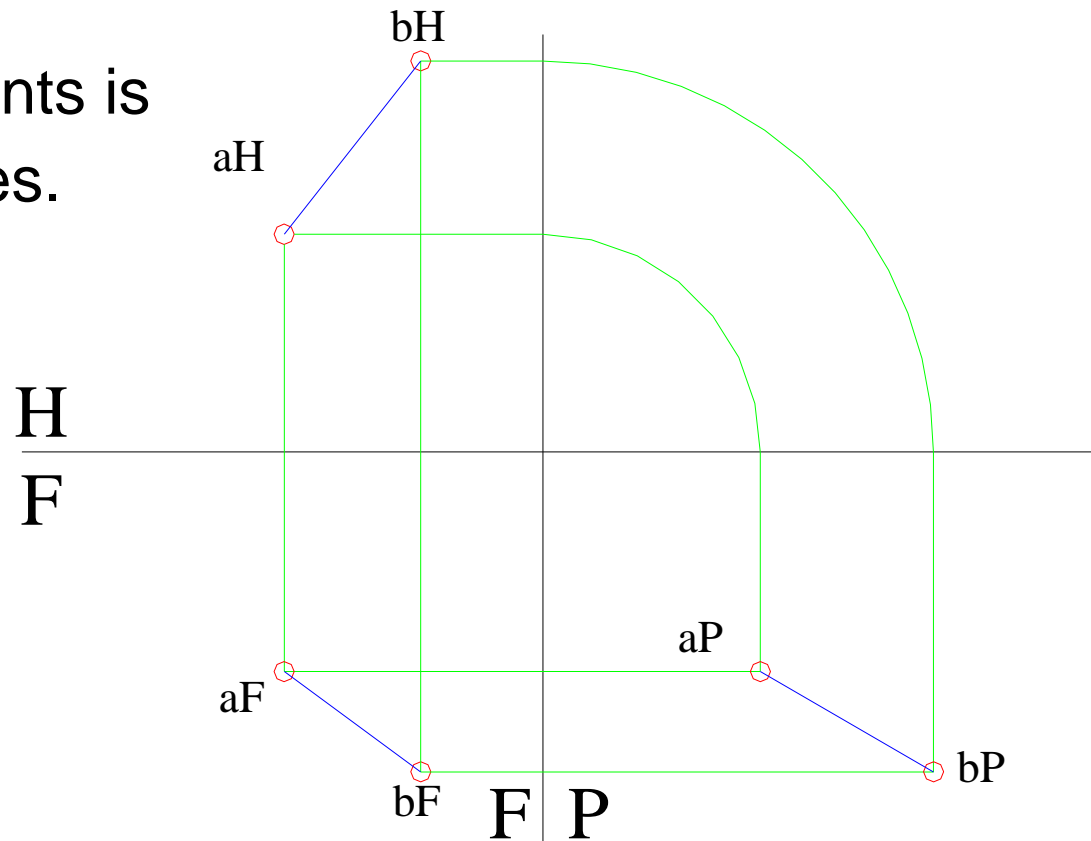
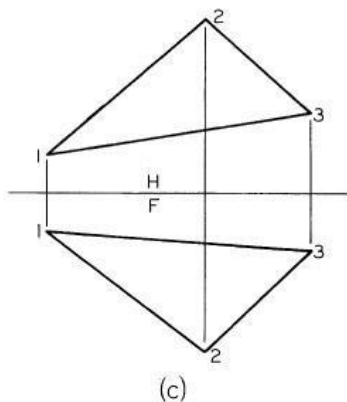
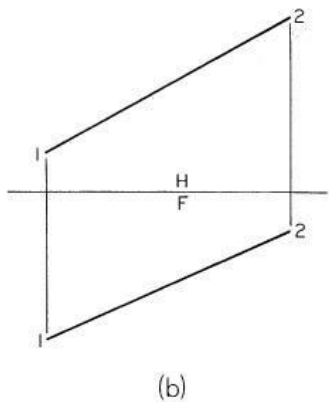

2. Multiple points - lines

- To describe an object, relative positions of ≥ 2 points are needed.
- Point 2 is 32mm to the right, 12mm below and 16mm behind point 1.
- The points are placed at specific distance and are connected to form a line.

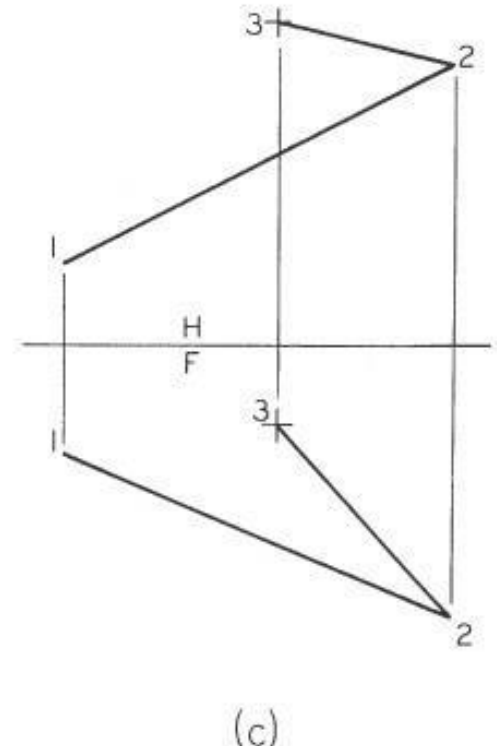
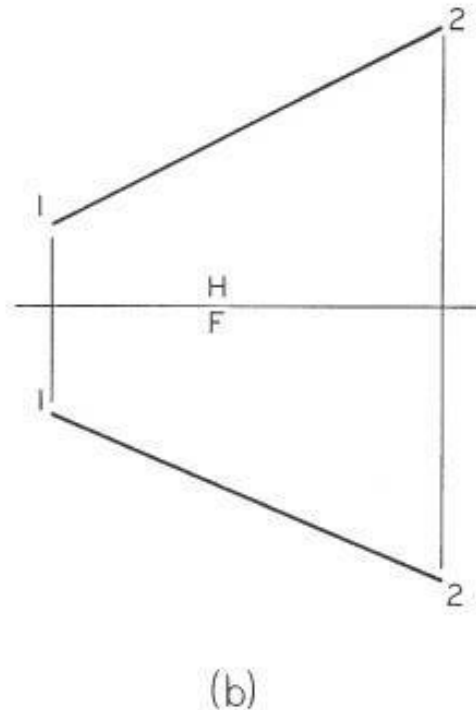
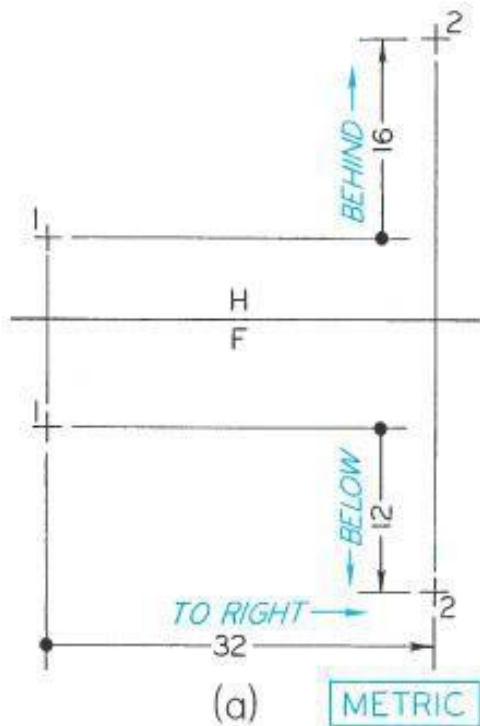

3. Location of a line

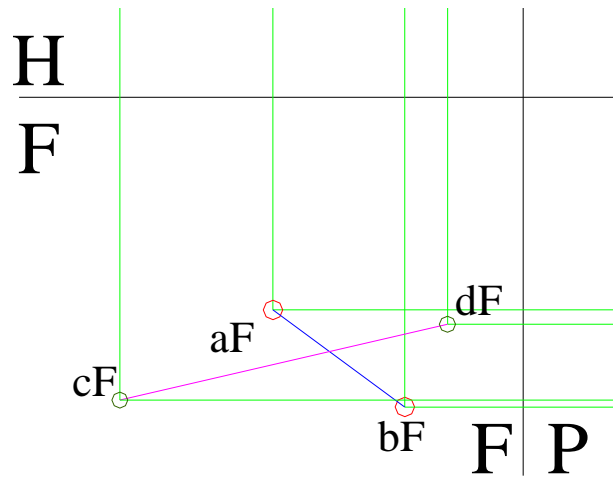

3. Location of a line

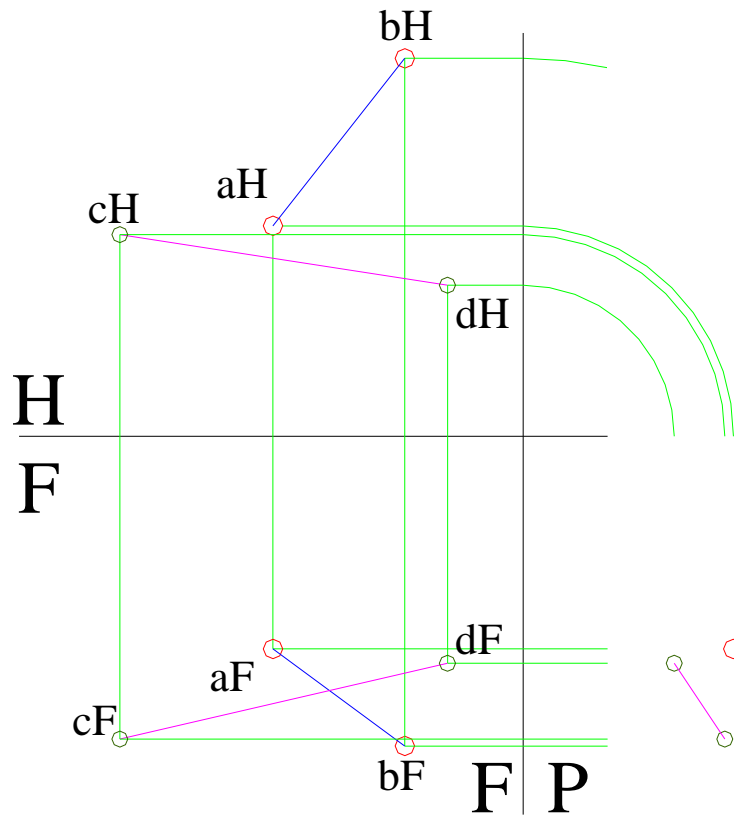

3. Location of a line

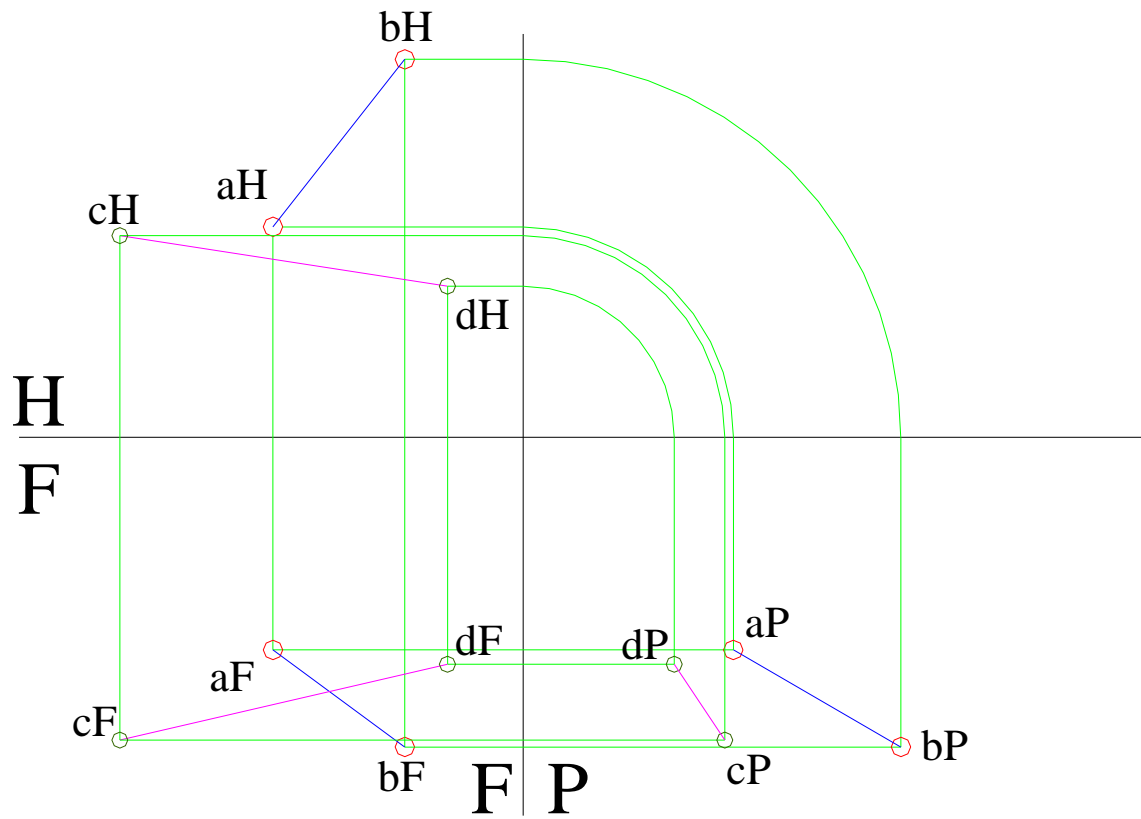

4. Particular positions of a line

- The inclined line appears as True Length on the plane to which it is parallel.
- They are termed as Frontal, Horizontal and Profile planes.
- TL view is always inclined while the other views are foreshortened.
- TL view gives more info, such as TA of the line to the plane of projection.
- In the frontal line, $\angle H$ and $\angle P$ can be found since the line is TL and planes are in EV.

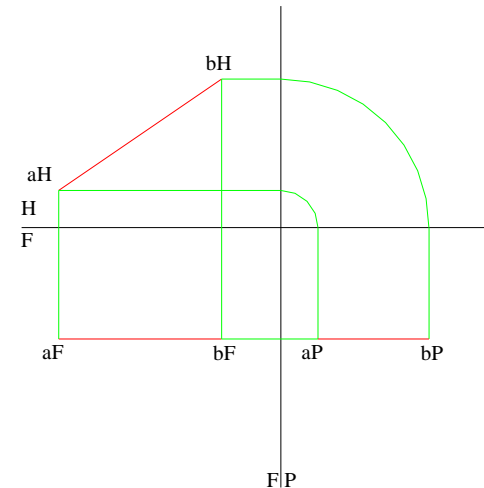

HORIZONTAL LINE

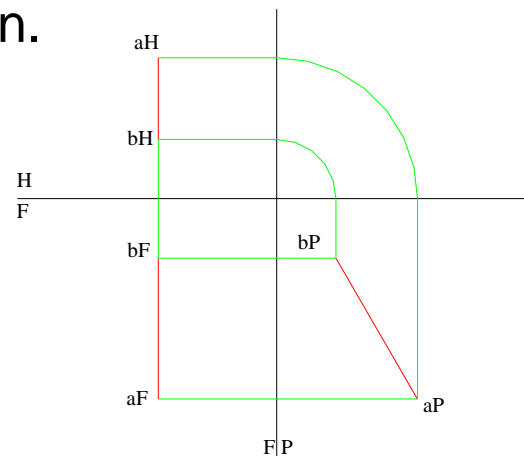

PROFILE LINE

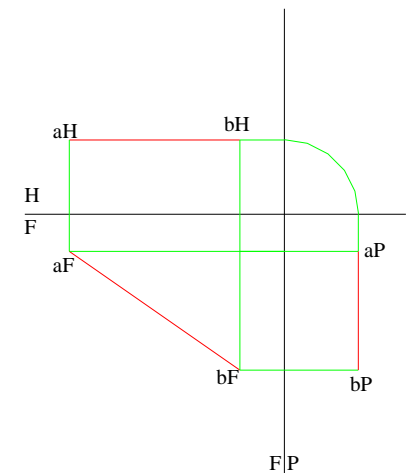

FRONTAL LINE

4. Particular positions of a line

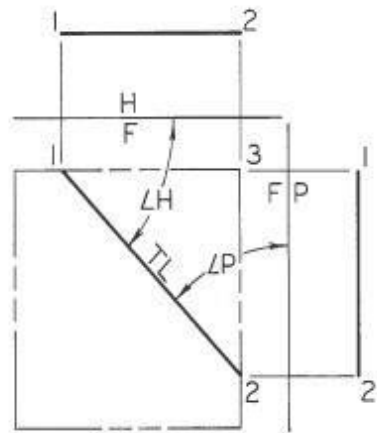
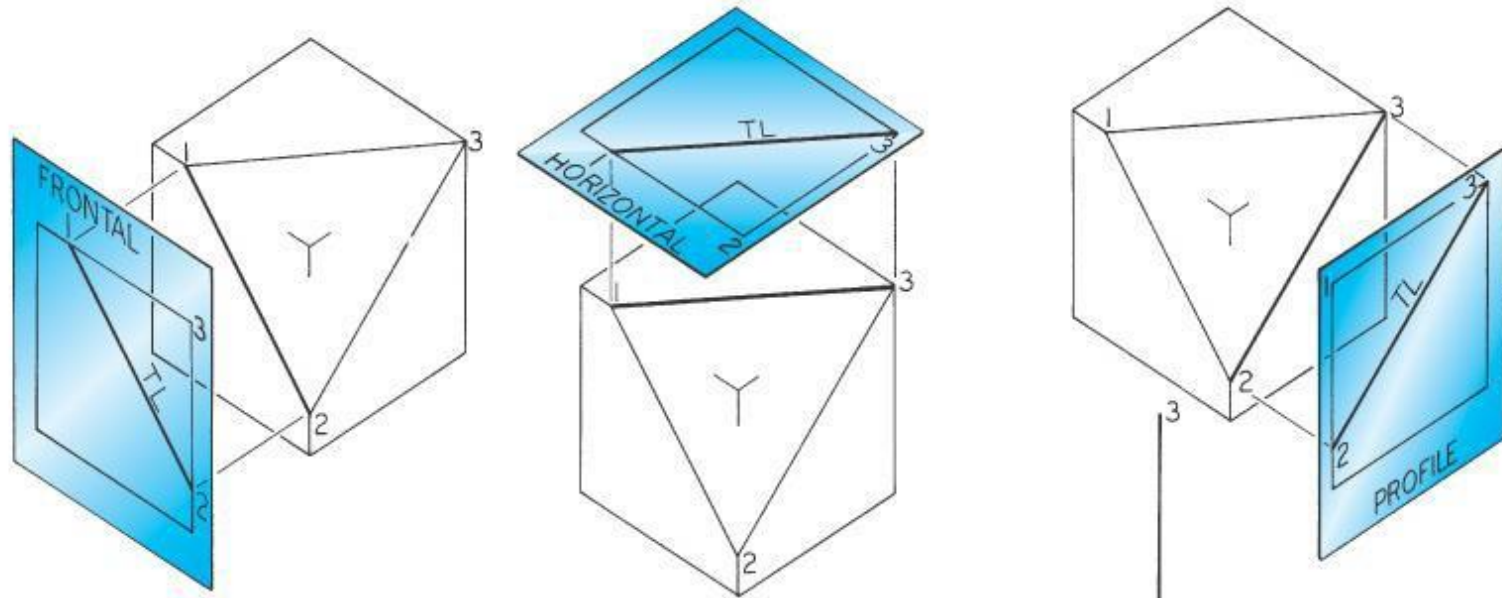

FRONTAL LINE 1-2

(a)

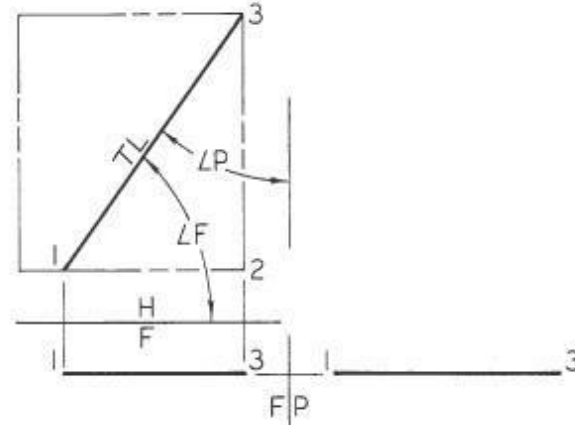

HORIZONTAL LINE 1-3

(b)

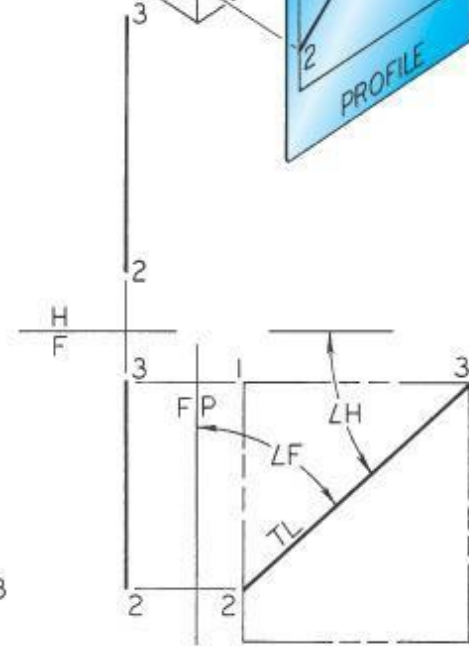

PROFILE LINE 2-3

(c)

5. True length of a oblique line

- The oblique line does not appear as TL in any principal views.
- An AUX view is needed. Here the depth of the AUX view and front view is created to find the TL of line 1-2.
- $\angle F$ can also be found as the plane of projection (the wall). All points are at distance D in the top view.

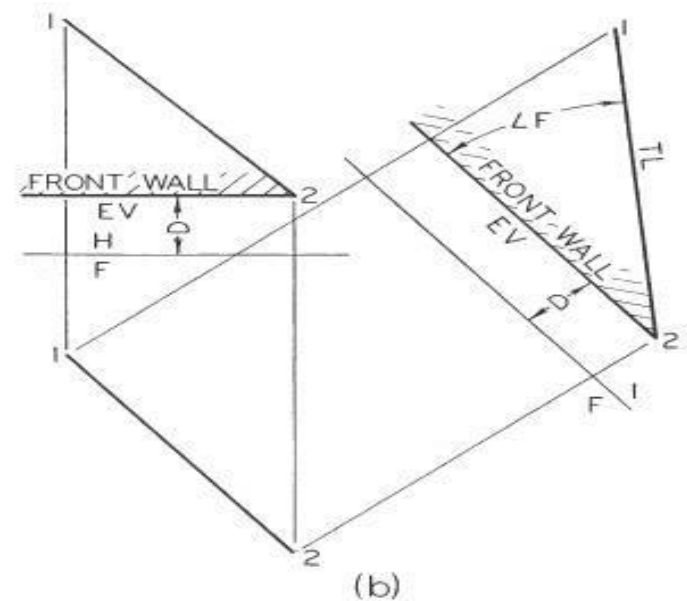
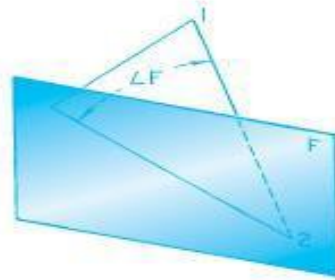
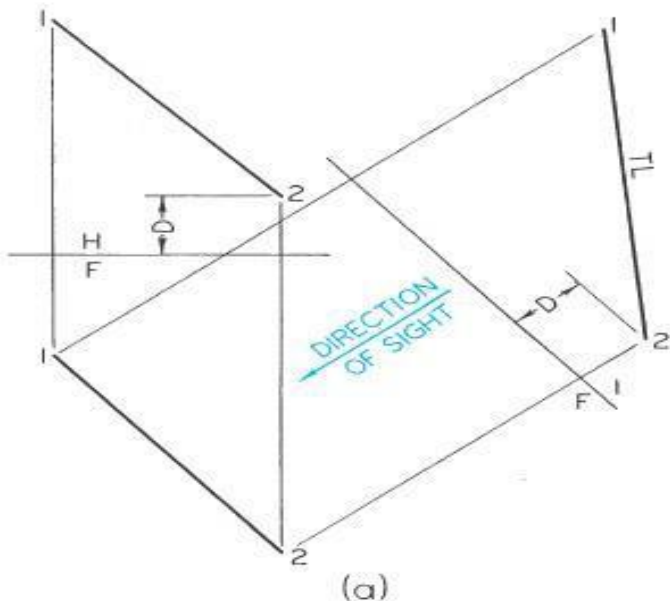

5. True length of a line

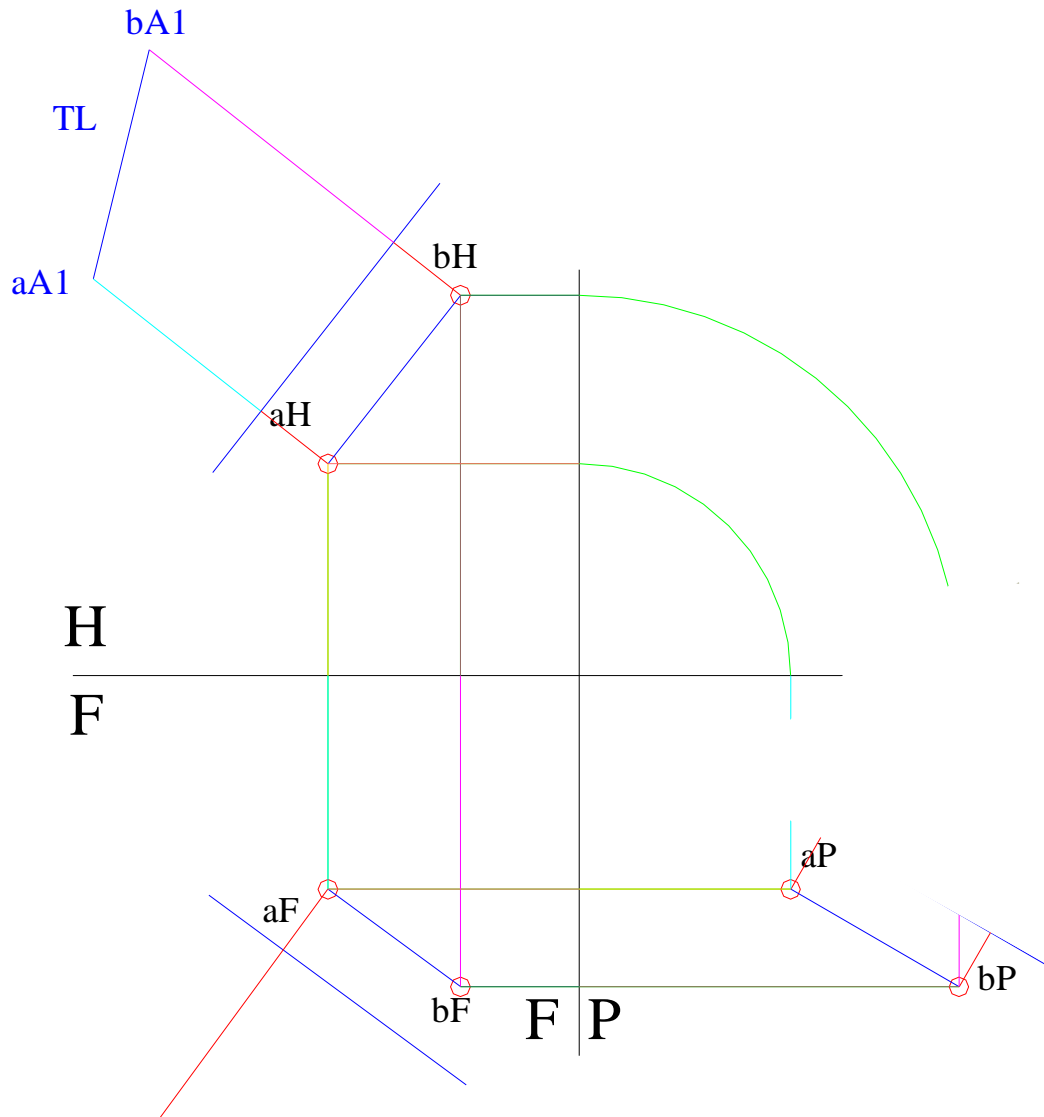

5. True length of a line

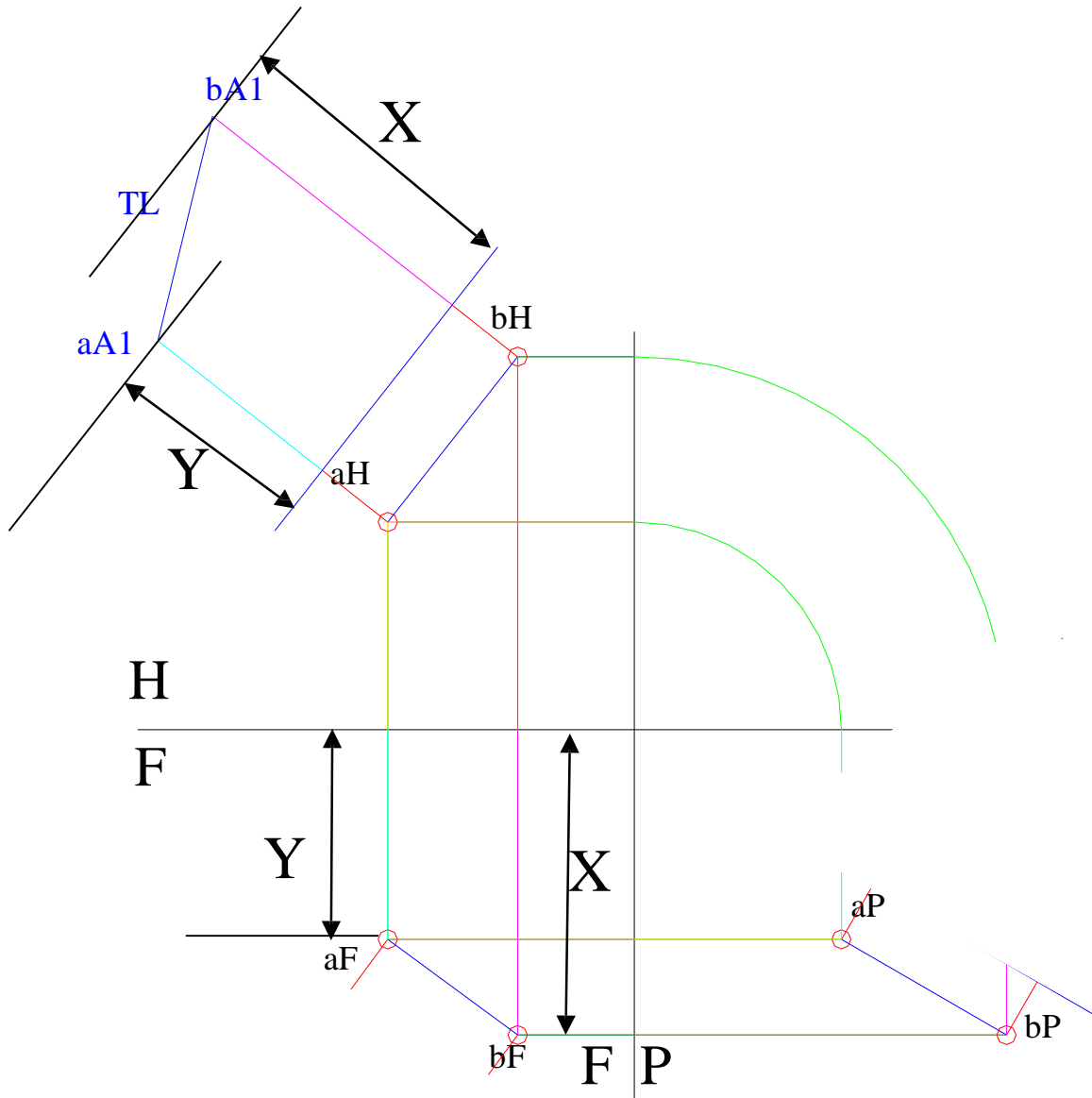

5. True length of a line

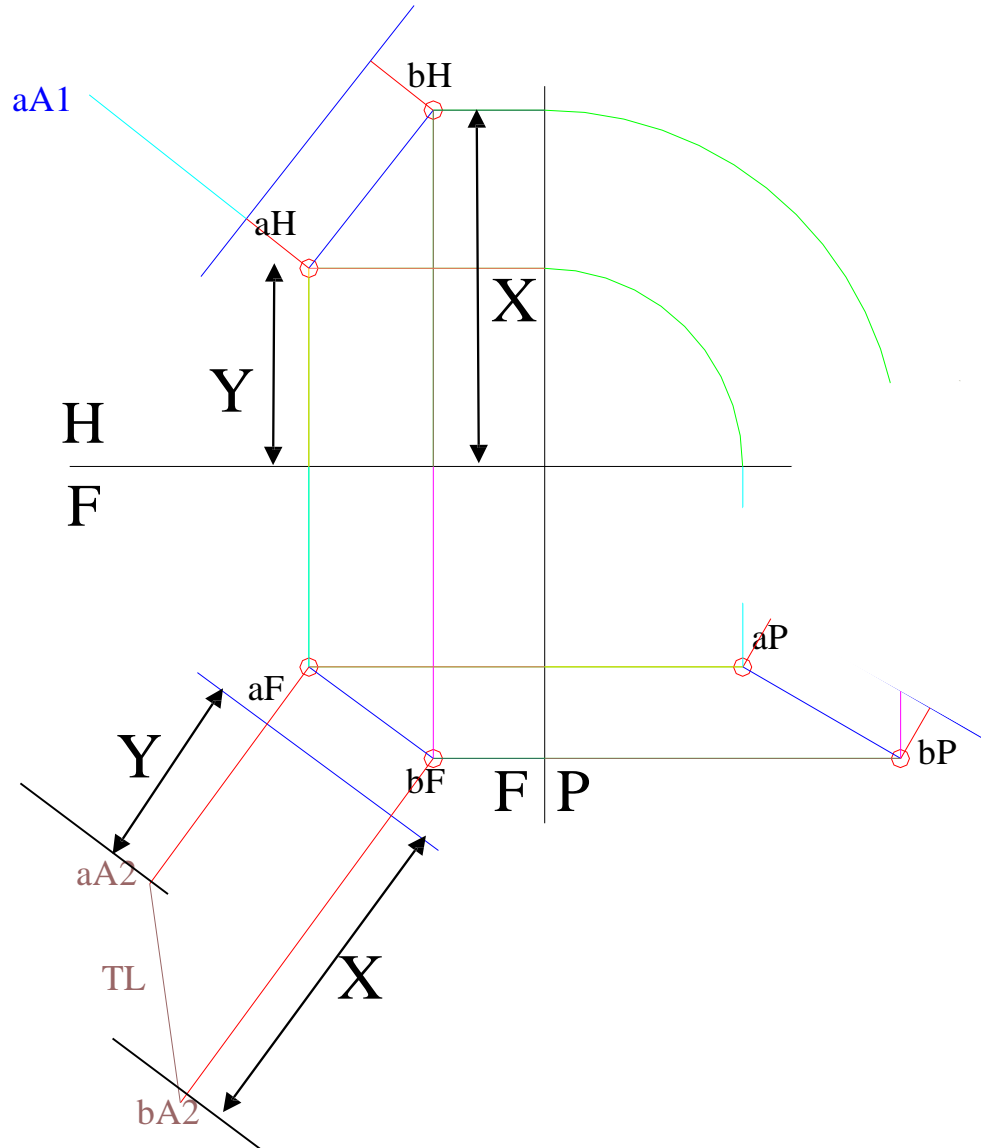

5. True length of a line

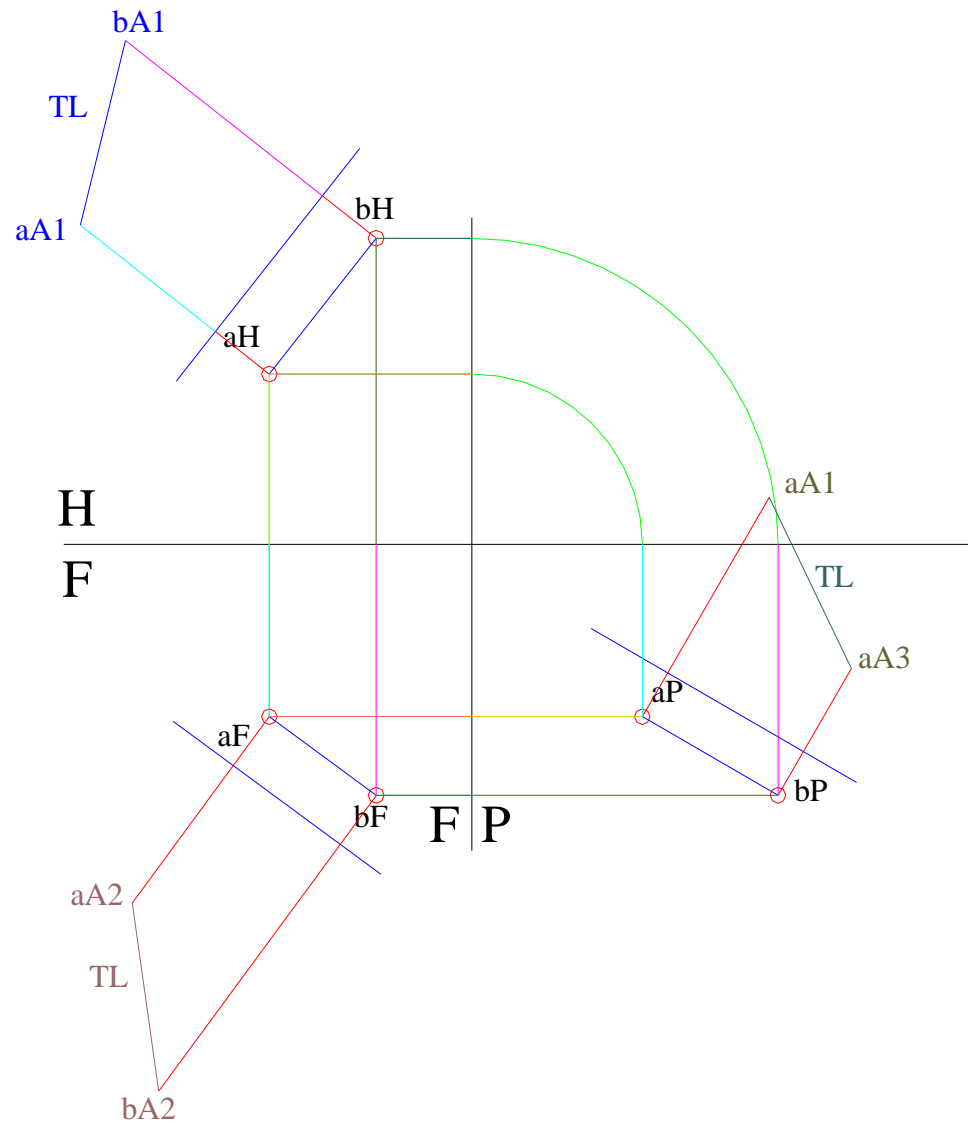

5'. True length of a line

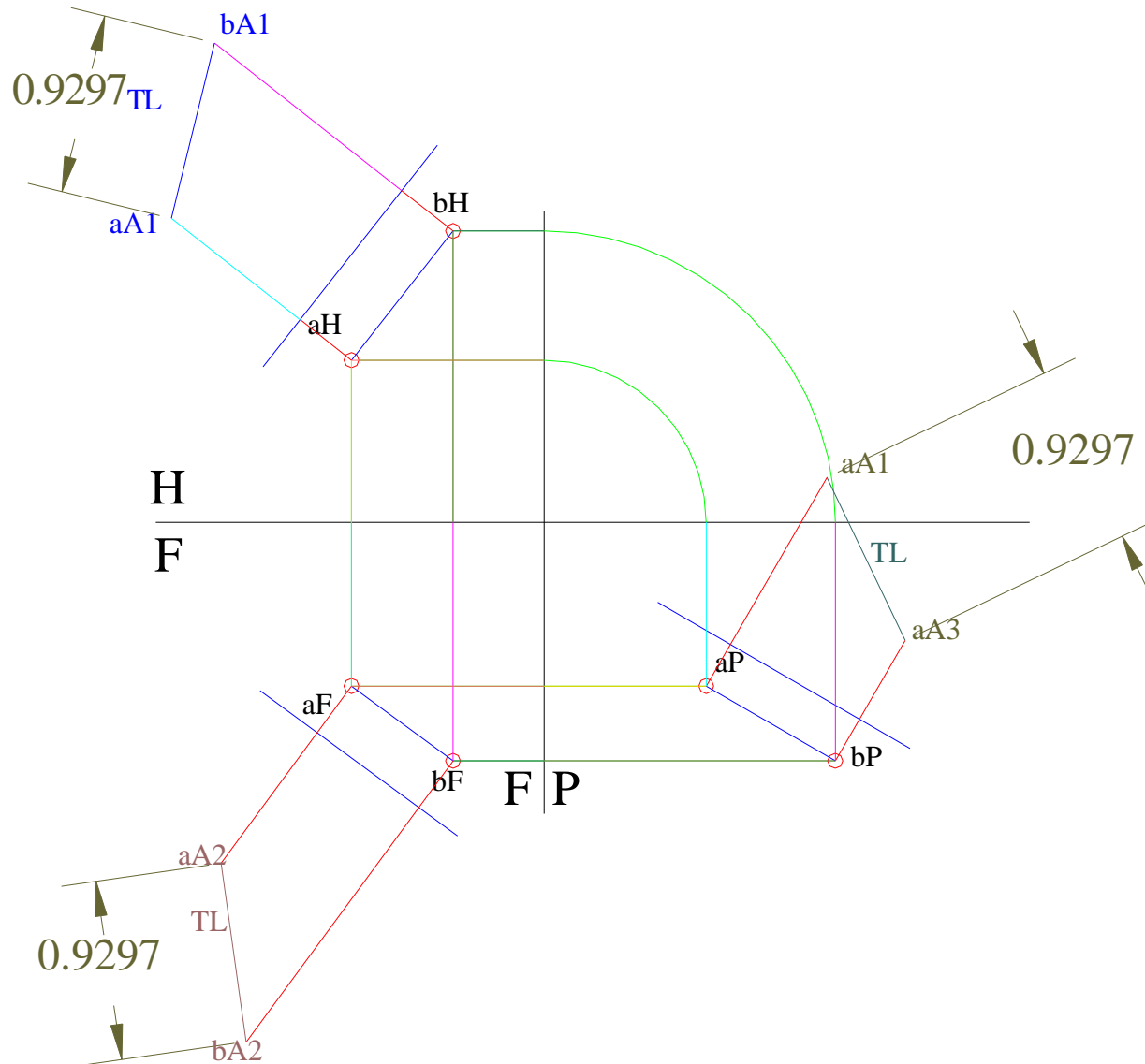

6. Bearing of a line

- The position of line in space can also be indicated by the bearing and slope of the line.
- If the earth is considered as flat, then a map is a top view.
- Thus the bearing of a line is measured with respect to north or south in the **top view** of the line.
- Generally upward is **N**, and generally **N** and **S** are used together with **E** and **W** to keep the \angle at less than 90° .

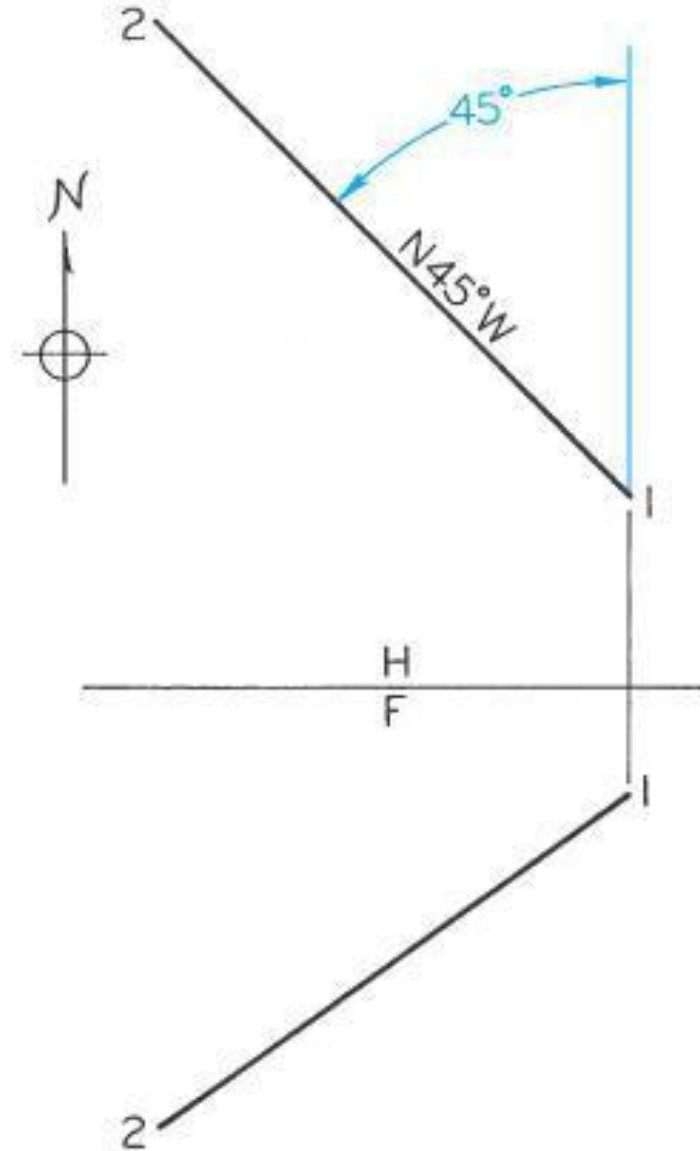

6. Bearing of a line

The bearing of a line is the direction of a line relative to N-S

The bearing of line AB is N38E

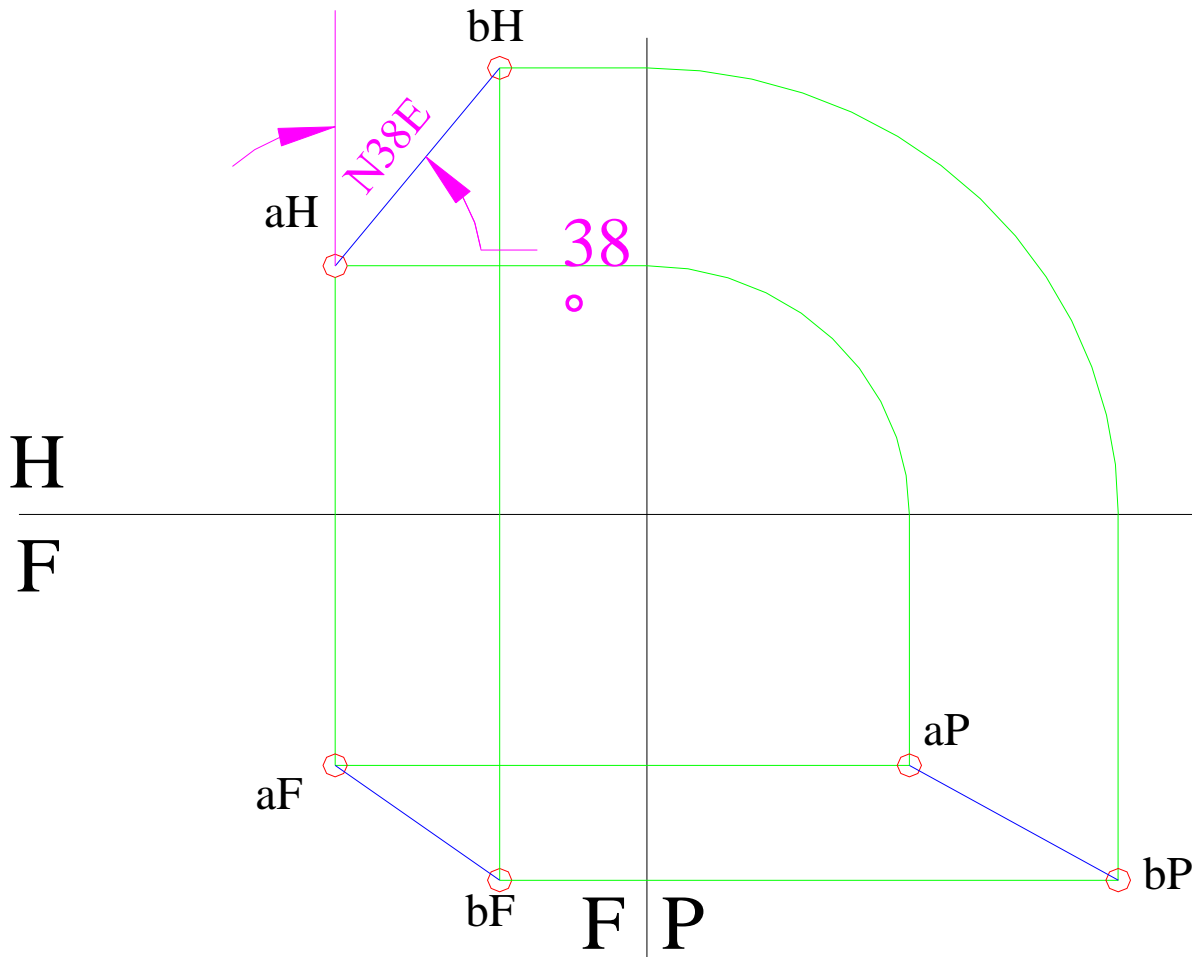

7. Slope of a line

- If the earth is considered as flat, then a map is a top view and the Horizontal plane is the most important plane.
- The angle between a line (eg. Road) and horizontal plane is the slope (important to describe).

- To measure slope of 1-2, a view must be got where the line is in TL and horizontal plane in EV.

- Horizontal plane is in EV in the front view and is // to HF.

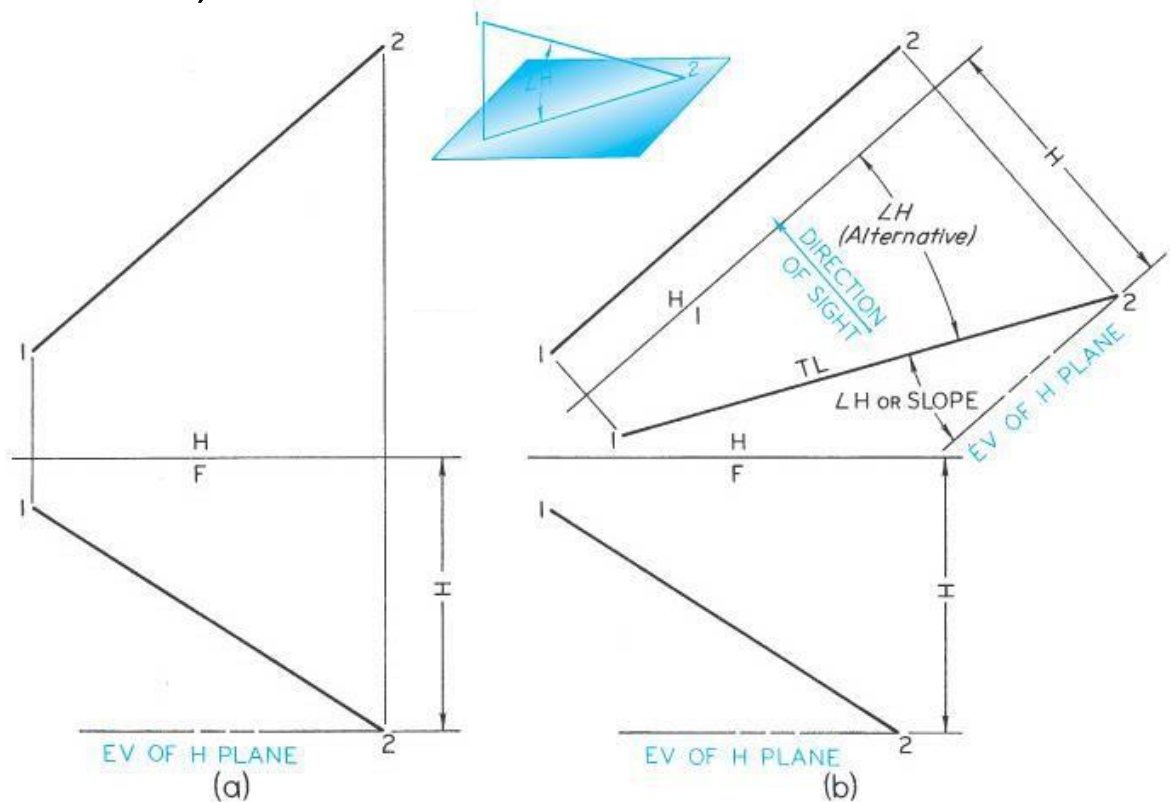

7. Slope of a line

The slope of line AB is -24° since the line descends from A to B (the distance from the point of the line to the horizontal plane direction increases

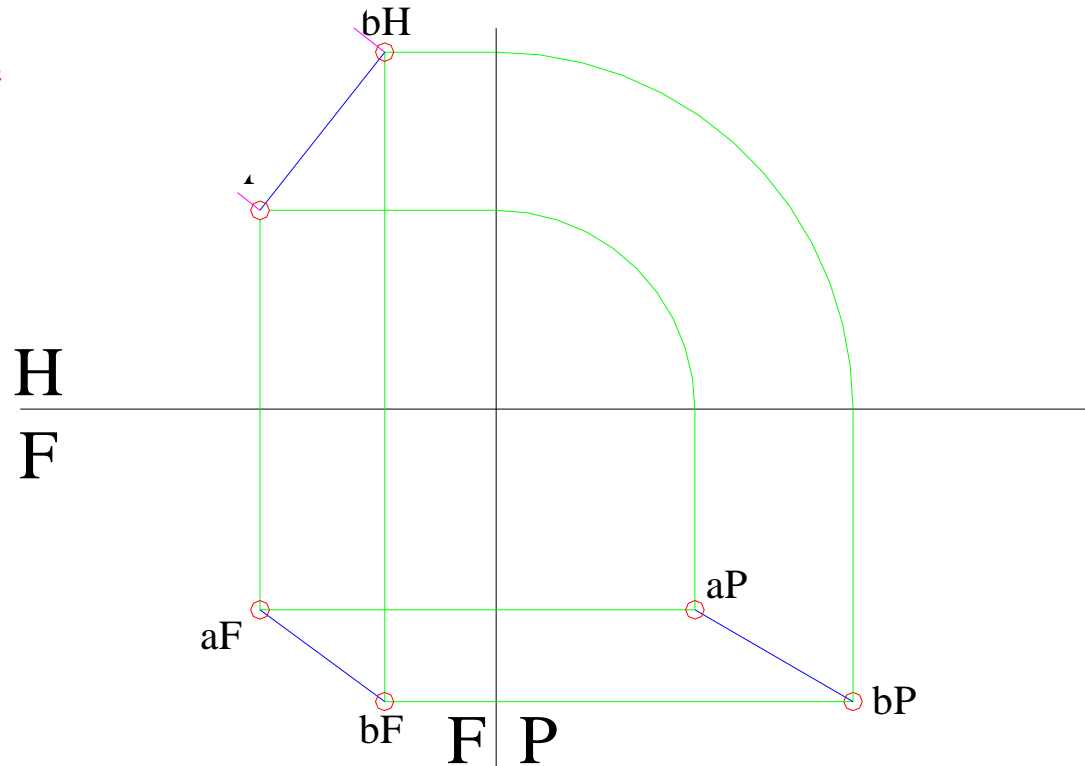

7. Slope of a line

Elevation view
- adjacent to the
top view

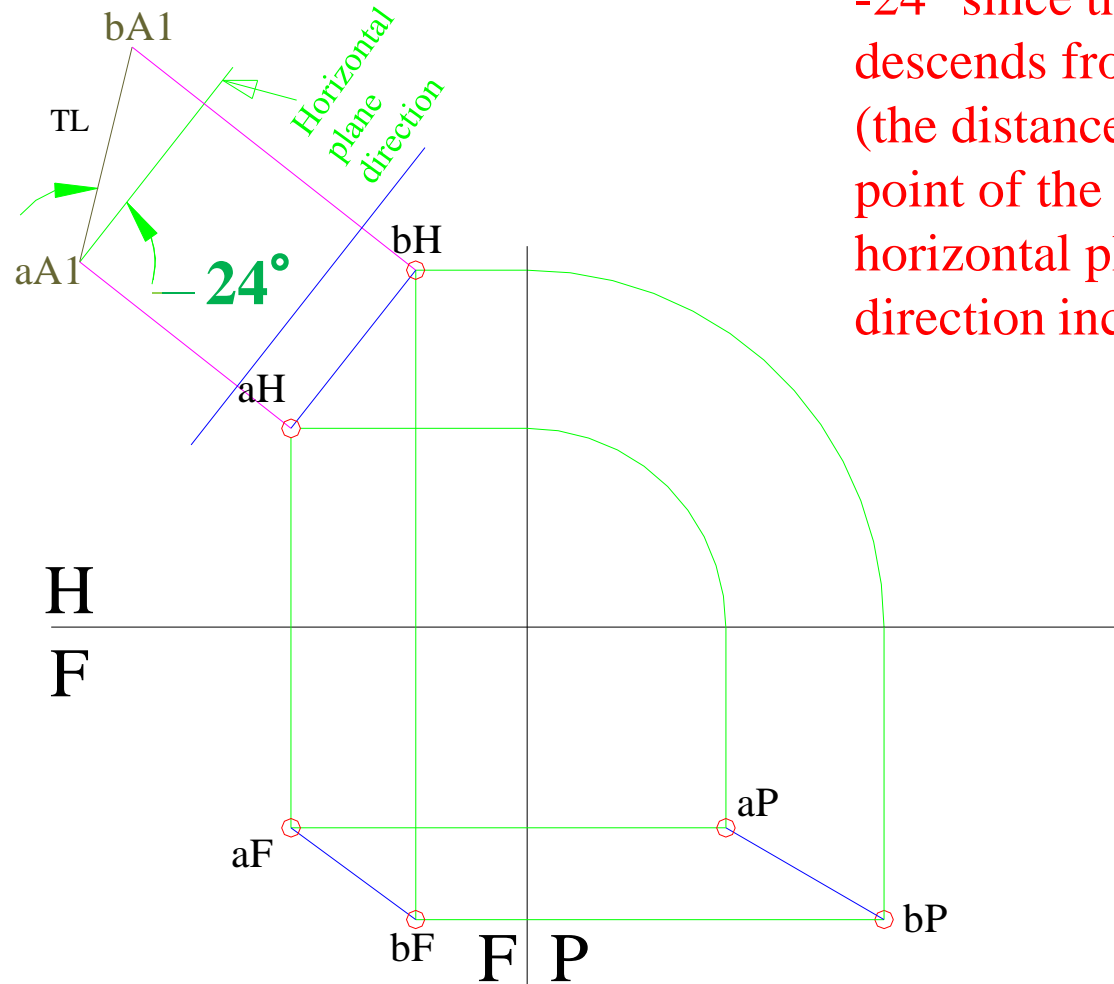

Slope of the line AB is -24° since the line descends from A to B (the distance from the point of the line to the horizontal plane direction increases)

8. Point view of a line

- If a direction of sight is \parallel to the TL view of the line, the line will appear as point.
- If a line is inclined, one auxiliary view is required.
- If line is oblique, two auxiliary view are required.
- Finding the shortest distance between a line and a point is important.



(a)

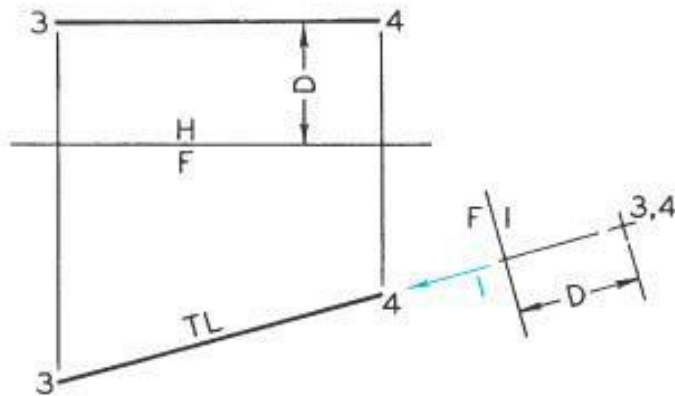

(b)

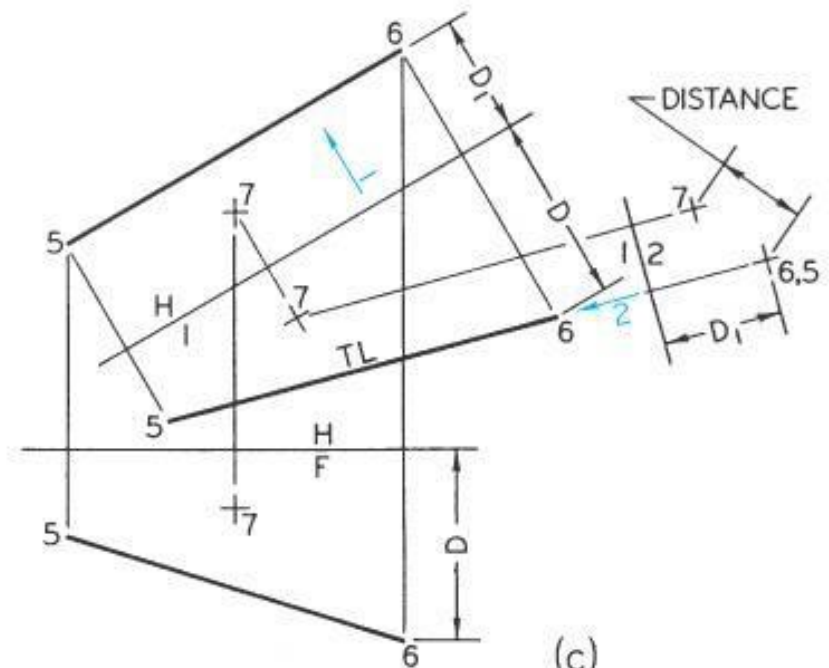

(c)

8. Point view of a line

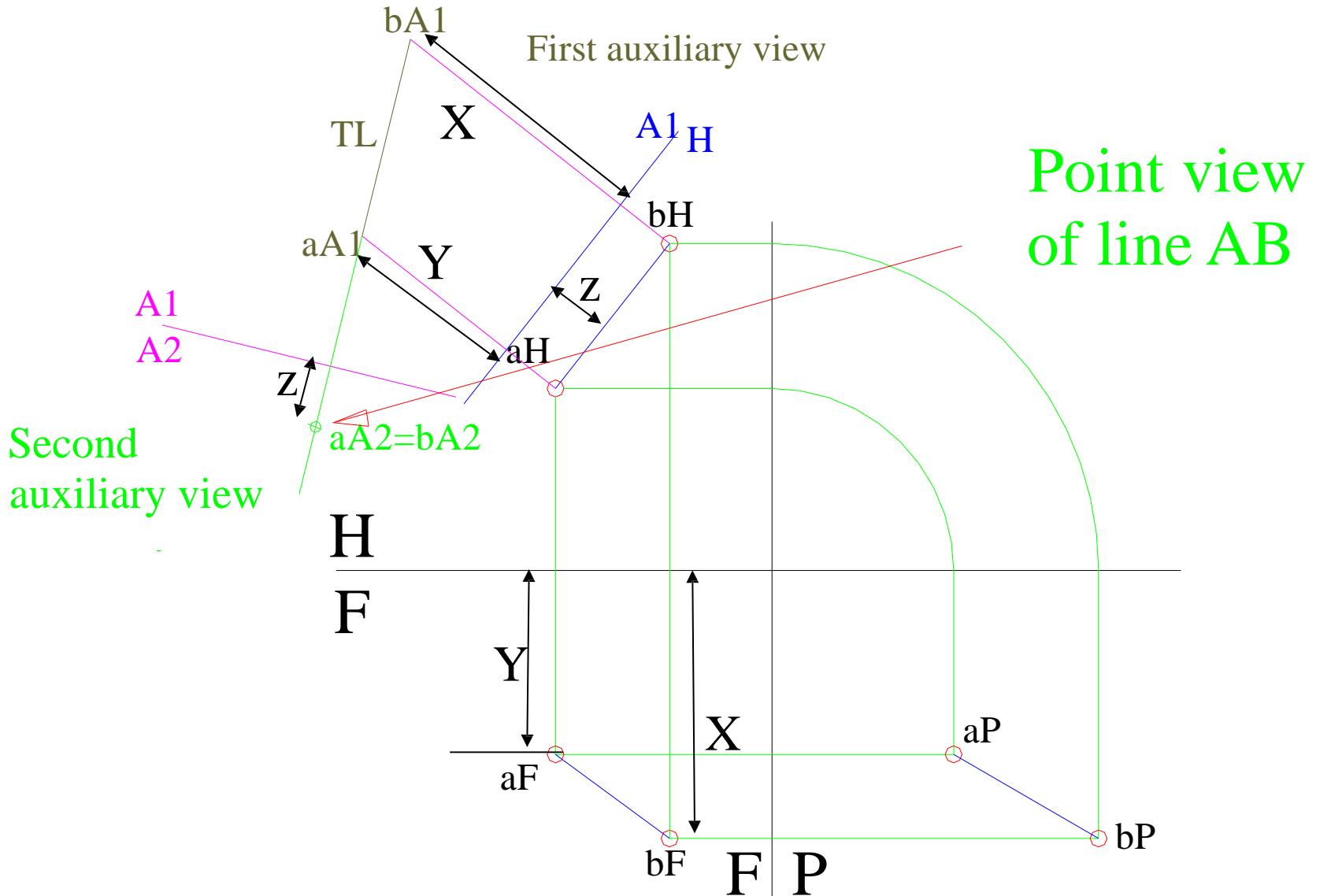

9. Relative position of a point vs. a line

- 1. Point C - on line AB
- 2. Point D - not on line AB

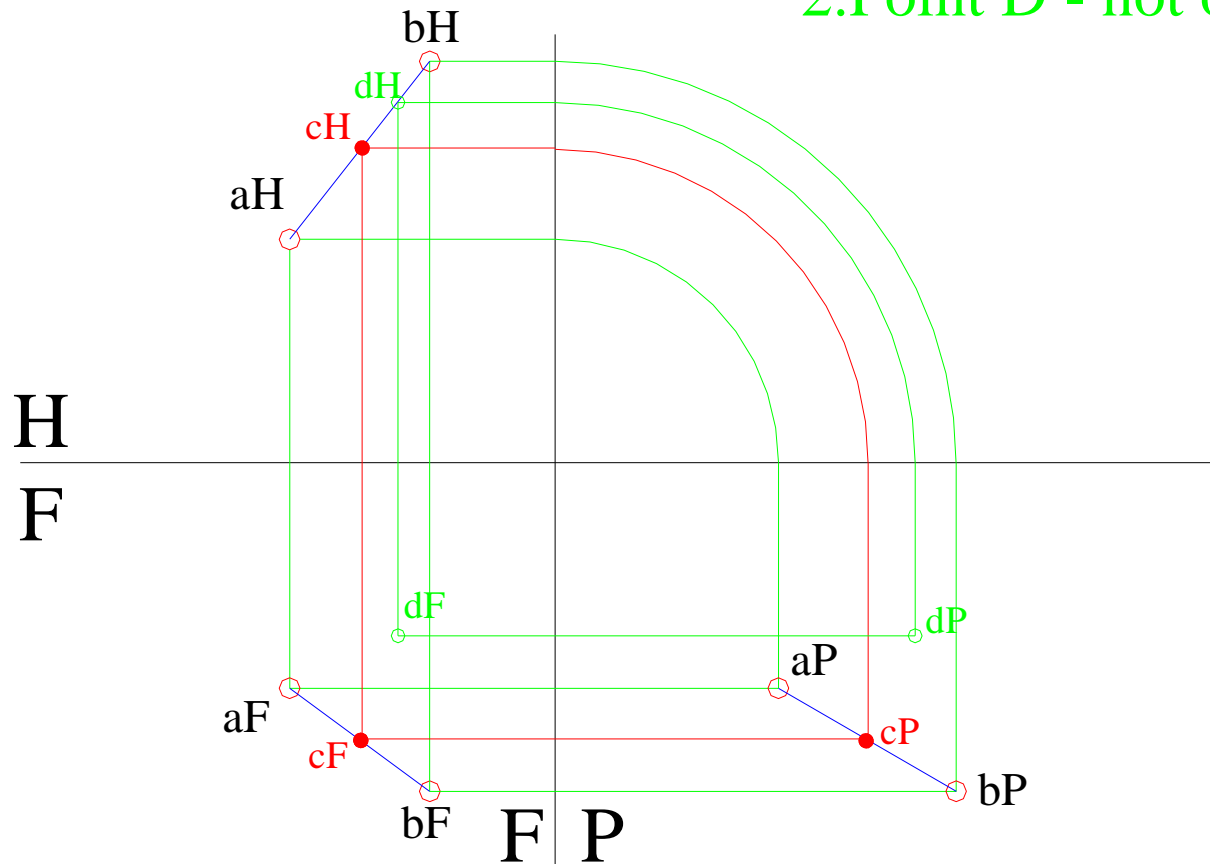

10. Relative position of two lines

- **Skew lines:** non intersecting, non-parallel and not coincident
 - **Intersecting lines:** one common point
 - **Parallel lines:** no common point
 - **Coincident lines:** overlapping – all points are common
- 

10a. Skew Lines

- Since skew lines don't intersect, they must go one over another.
- If you plot 5,6 (arbitrarily one point to one line) on TV and project it to FV – we can see which line is passing above the other line.

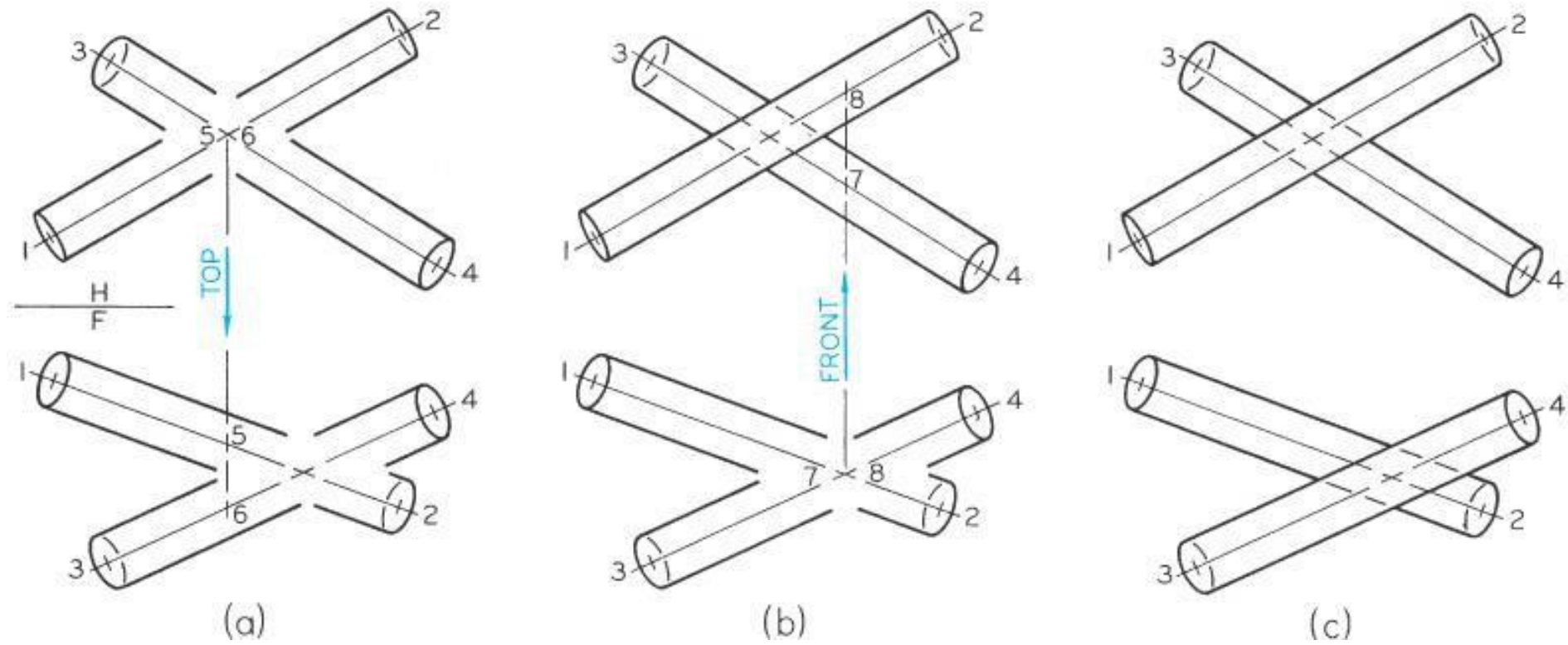

10b. Parallel Lines

- Parallel lines do not have common points between them.
- Parallel lines are seen as parallel in adjacent views. The exception is when the lines are perpendicular to the FL, the lines may or may not be parallel.

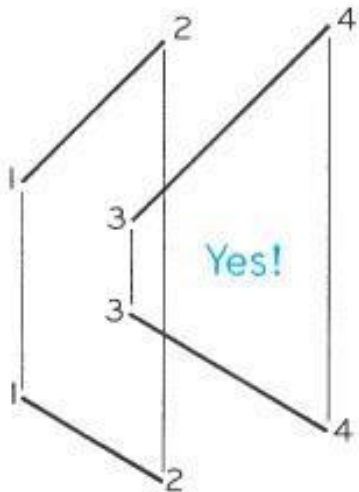

(a)

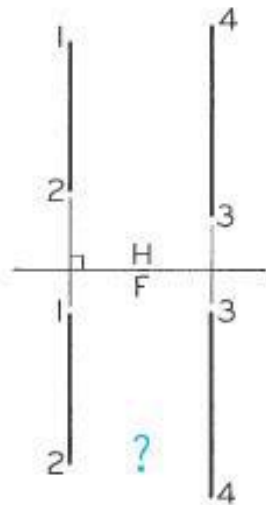

(b)

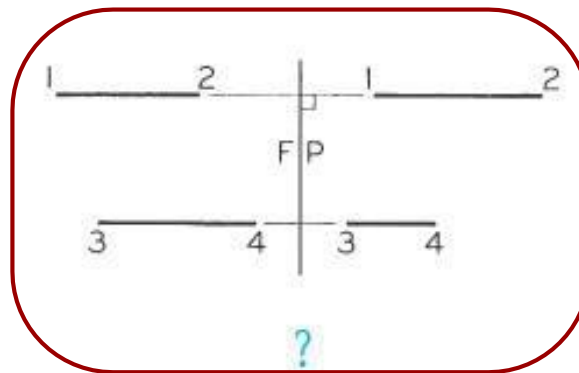

(c)

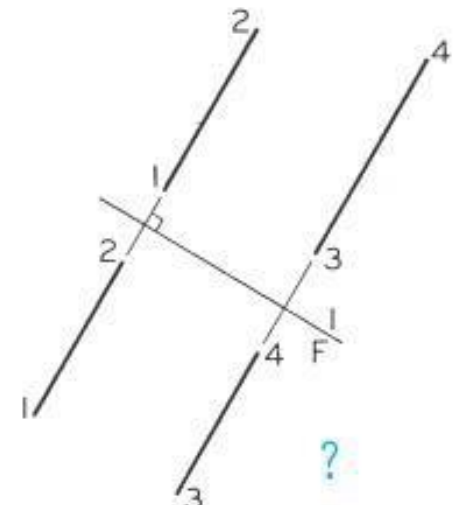

(d)

10b. Parallel Lines

- To find out if the lines are parallel, even if the lines are perpendicular to the FL, it is best to draw the 3rd view
- If it is required to get the lines parallel, then use one view, draw the lines parallel and complete the 3rd view

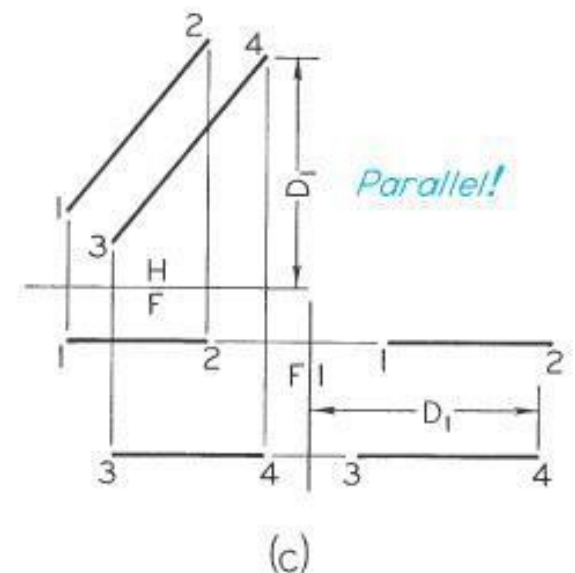
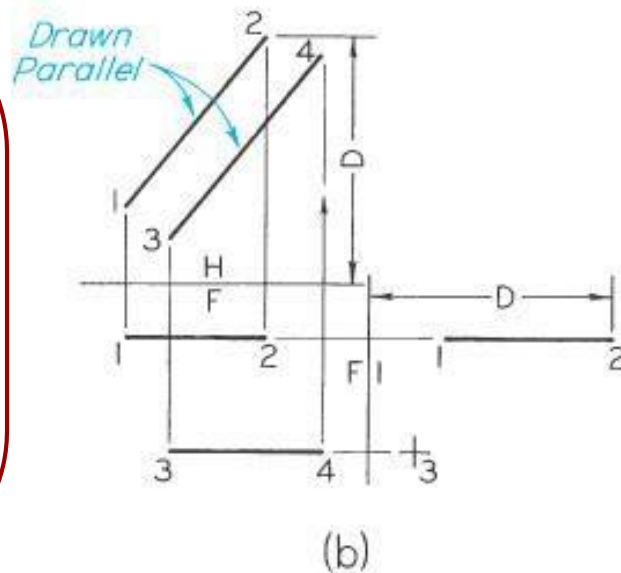
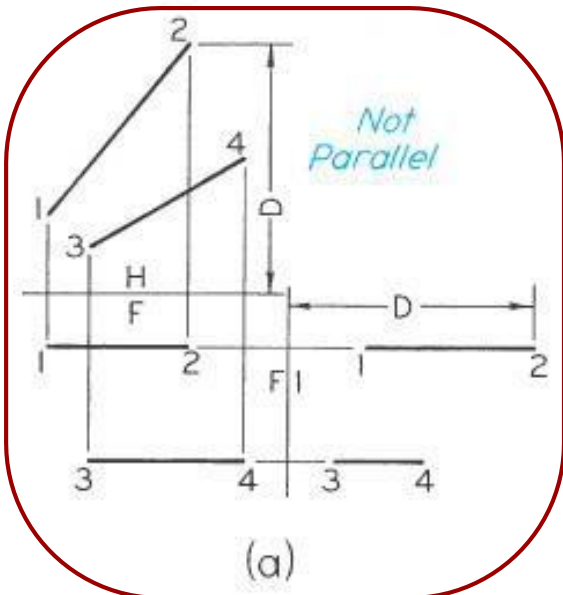

10. Parallel lines

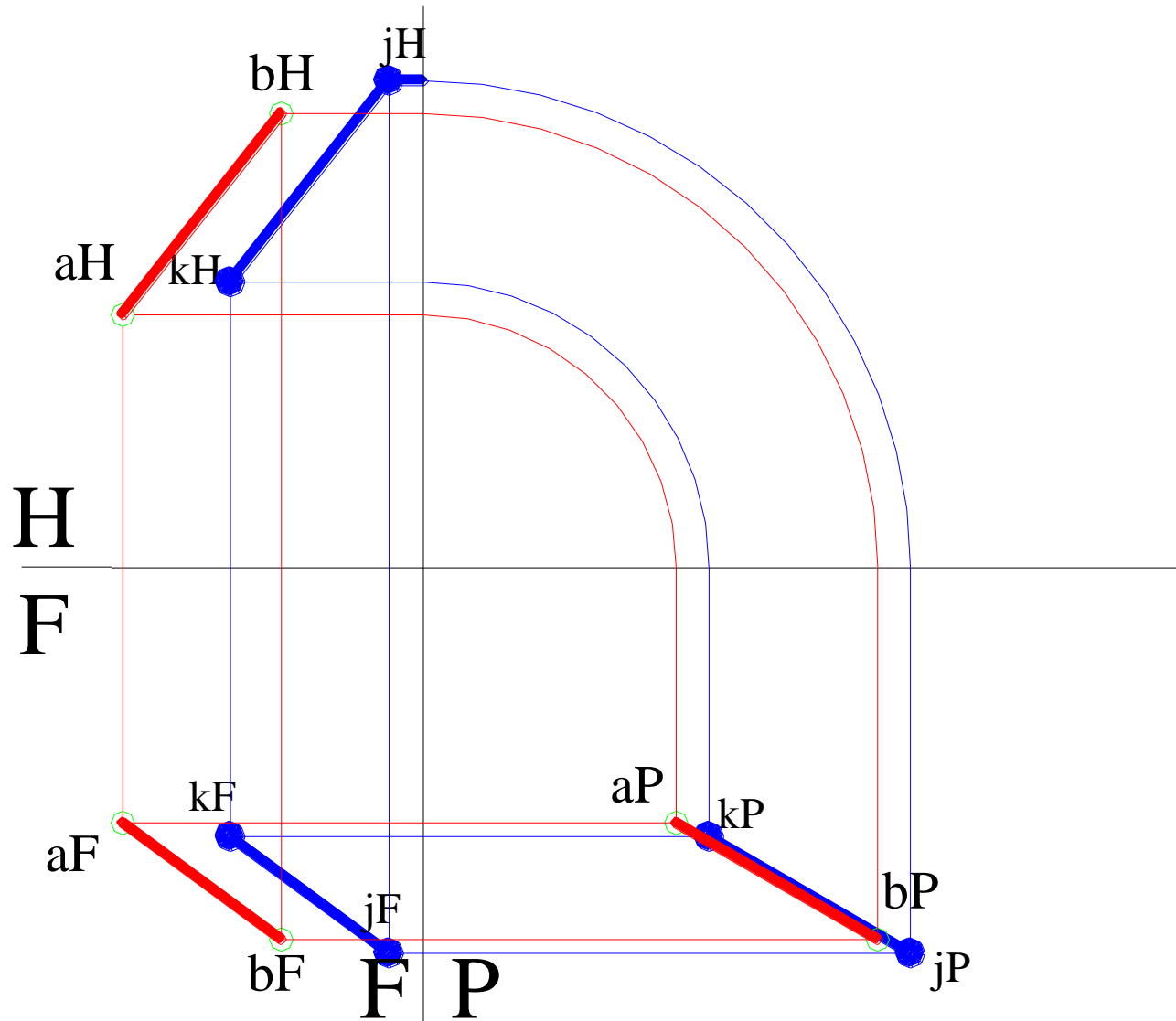

10c. Intersecting Lines

- Intersecting lines have one common point between them.
- The projection of the points must be aligned in adjacent views.
- If they are, then the lines are intersecting.
- If not, they are skewed.

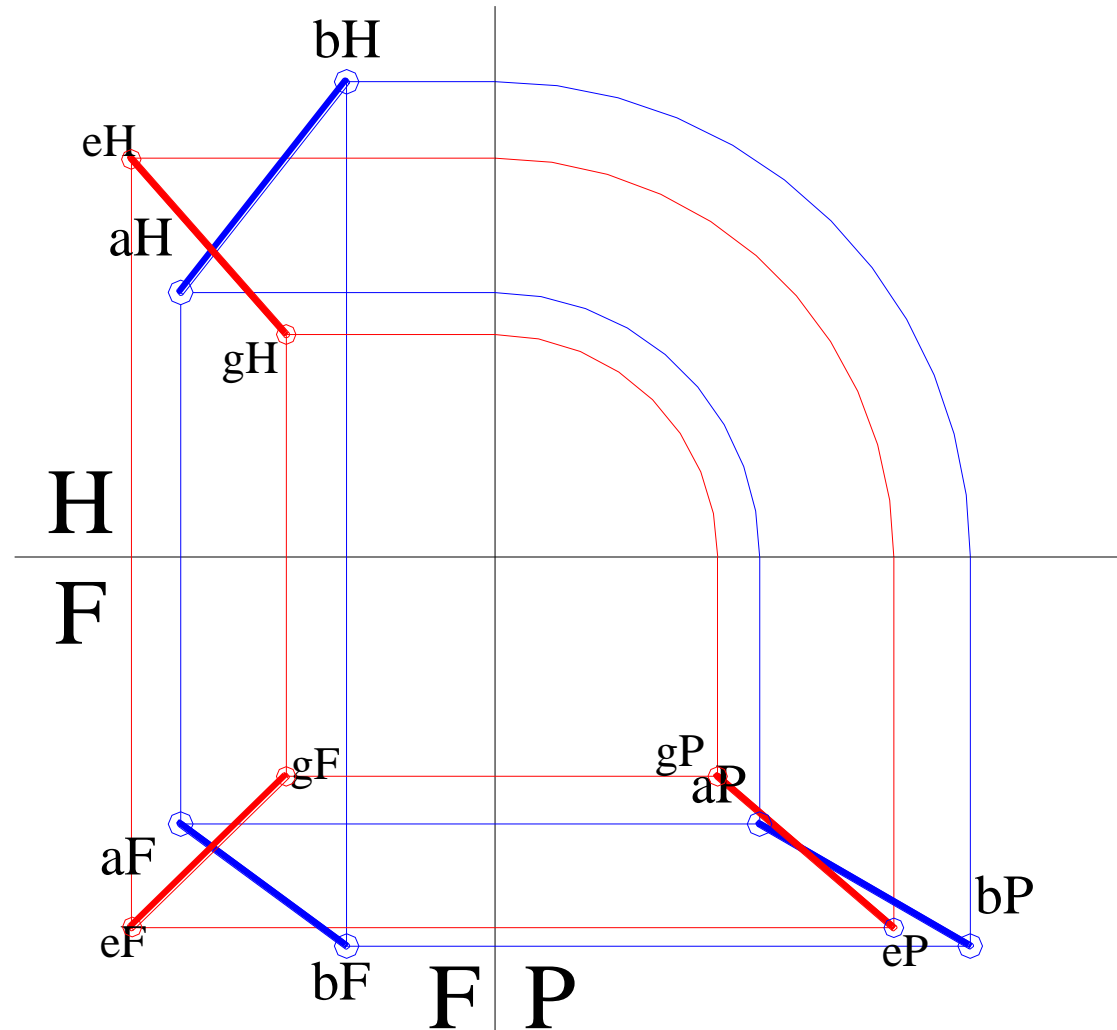

10c. Intersecting Lines

- Intersecting lines have one common point between them.
- The projection of the points must be aligned in adjacent views.
- If they are, then the lines are intersecting.
- If not, they are skewed.

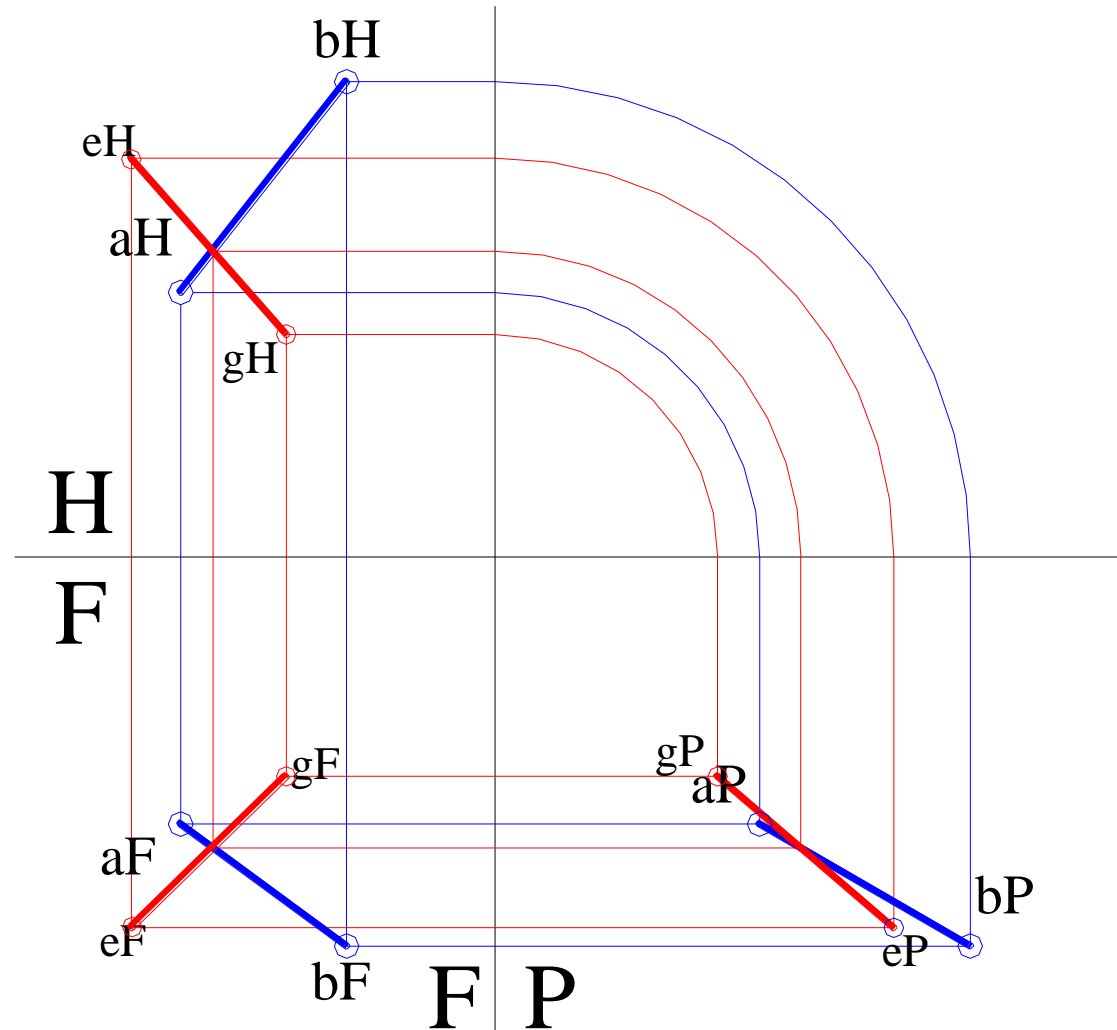

10. Coincident lines

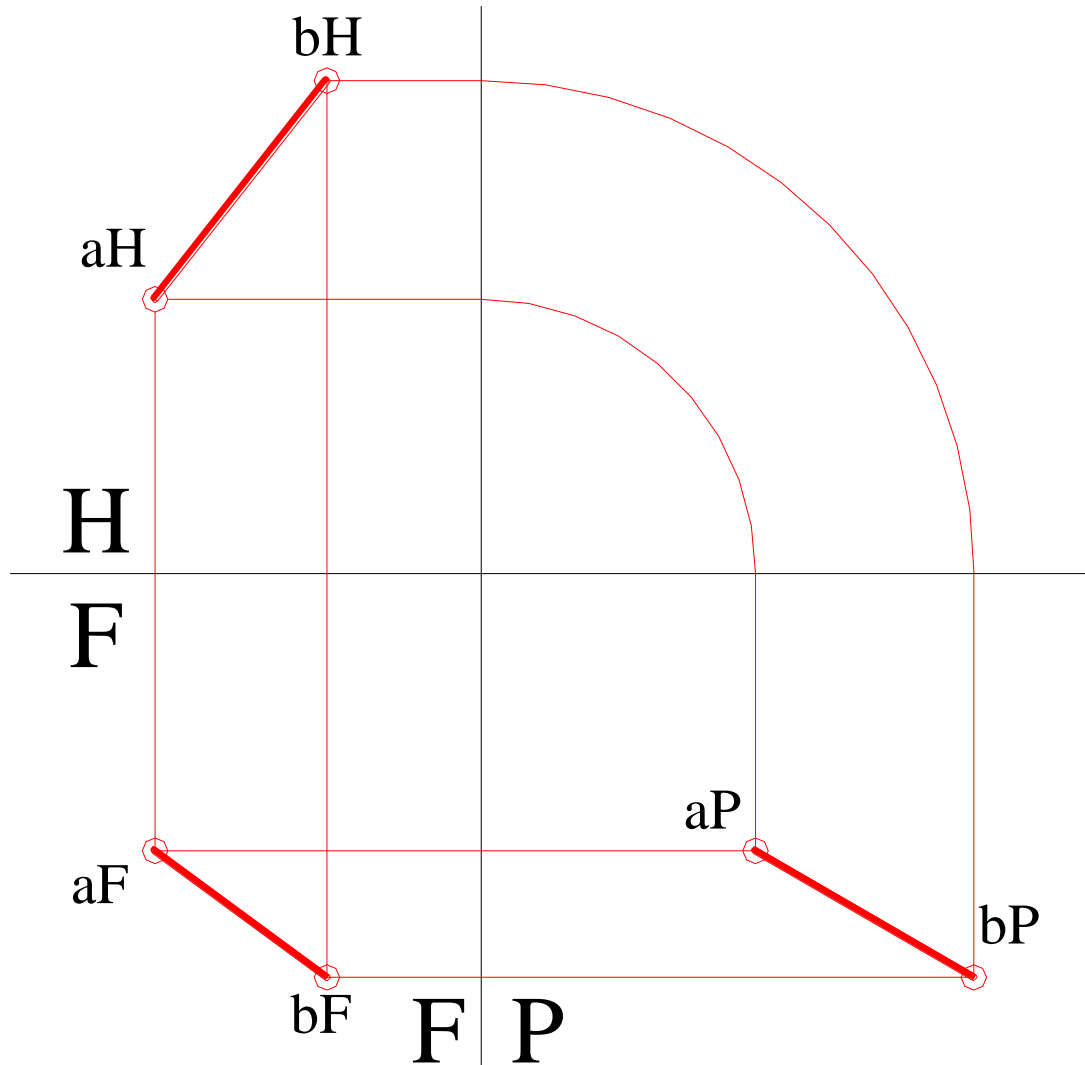

11. Rule of parallel lines

Parallel lines are seen parallel in all views.

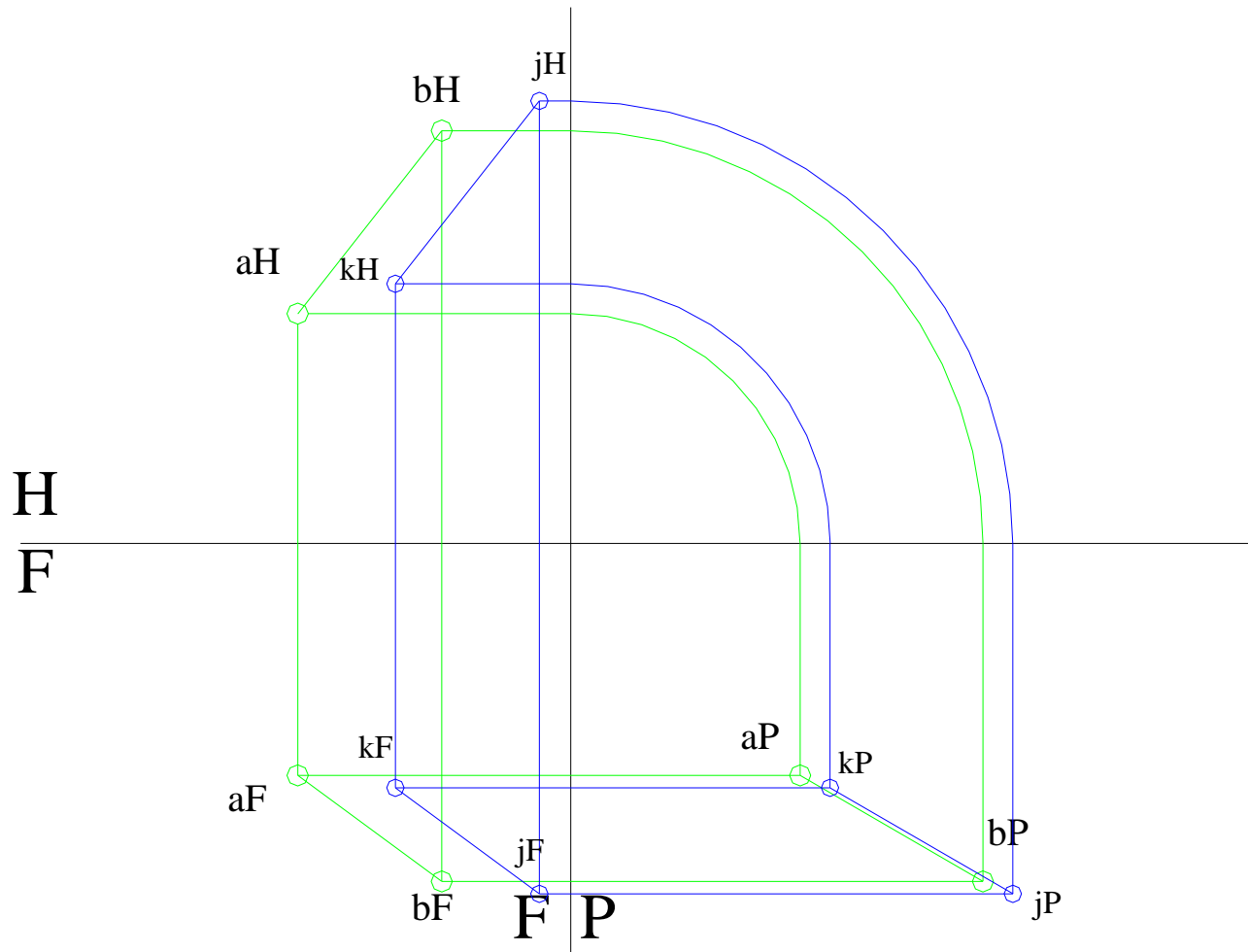

12. Location of a line parallel to a given line passing through a point

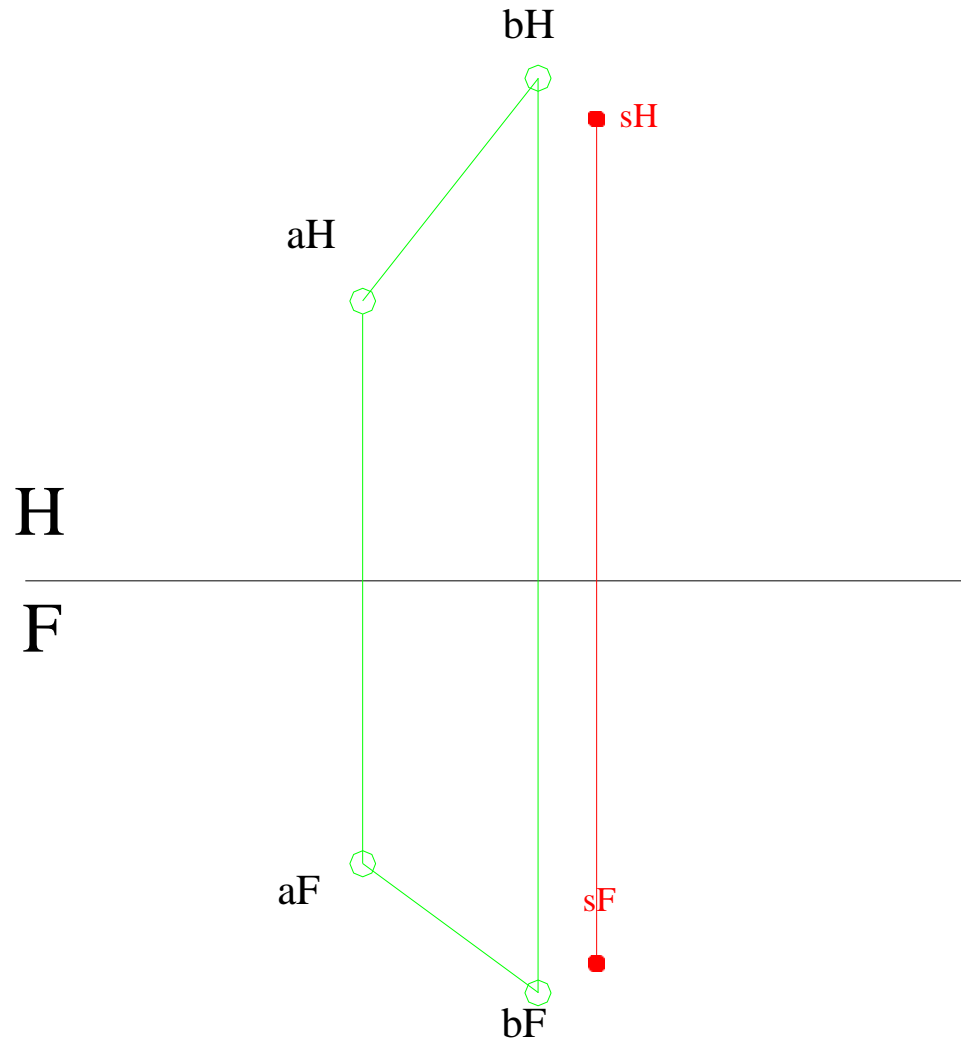

12. Location of a line parallel to a given line passing through a point

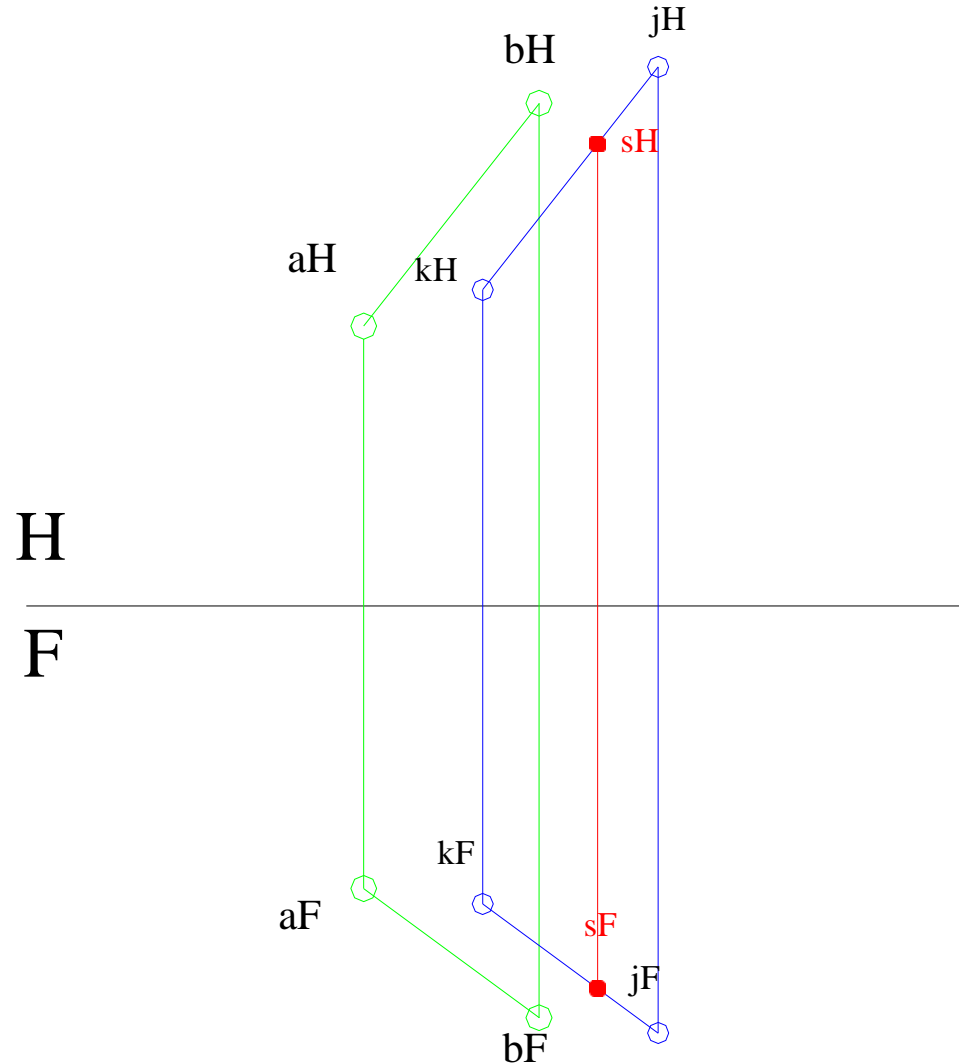

13. True distance between two parallel lines

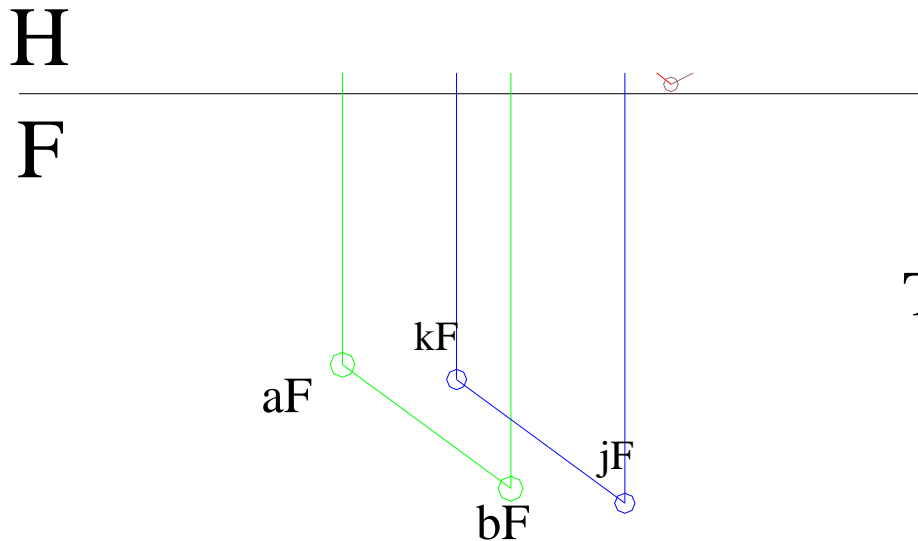
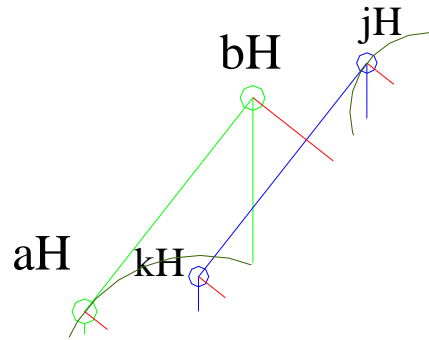

Two auxiliary views

13. True distance between two parallel lines

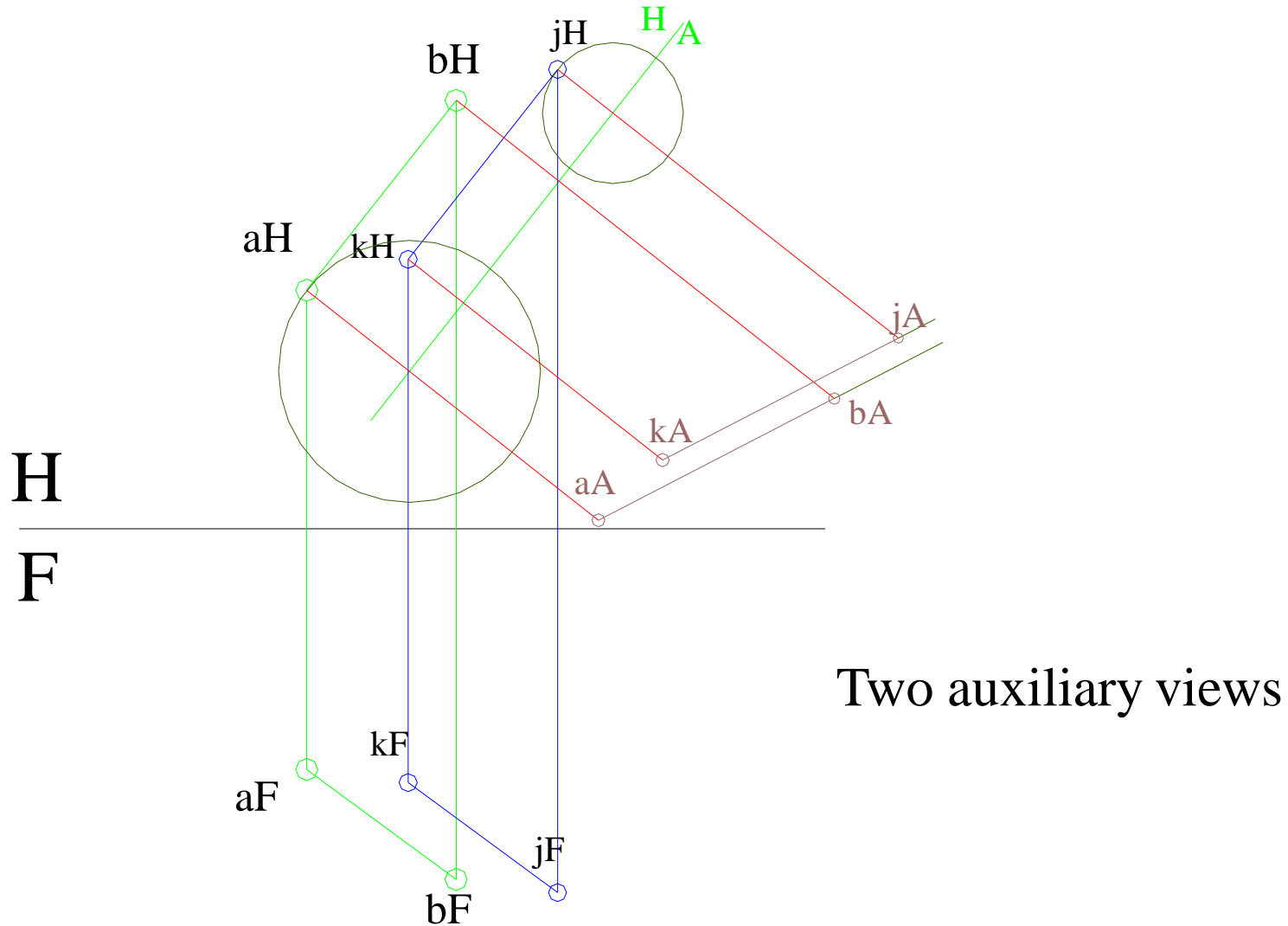

13. True distance between two parallel lines

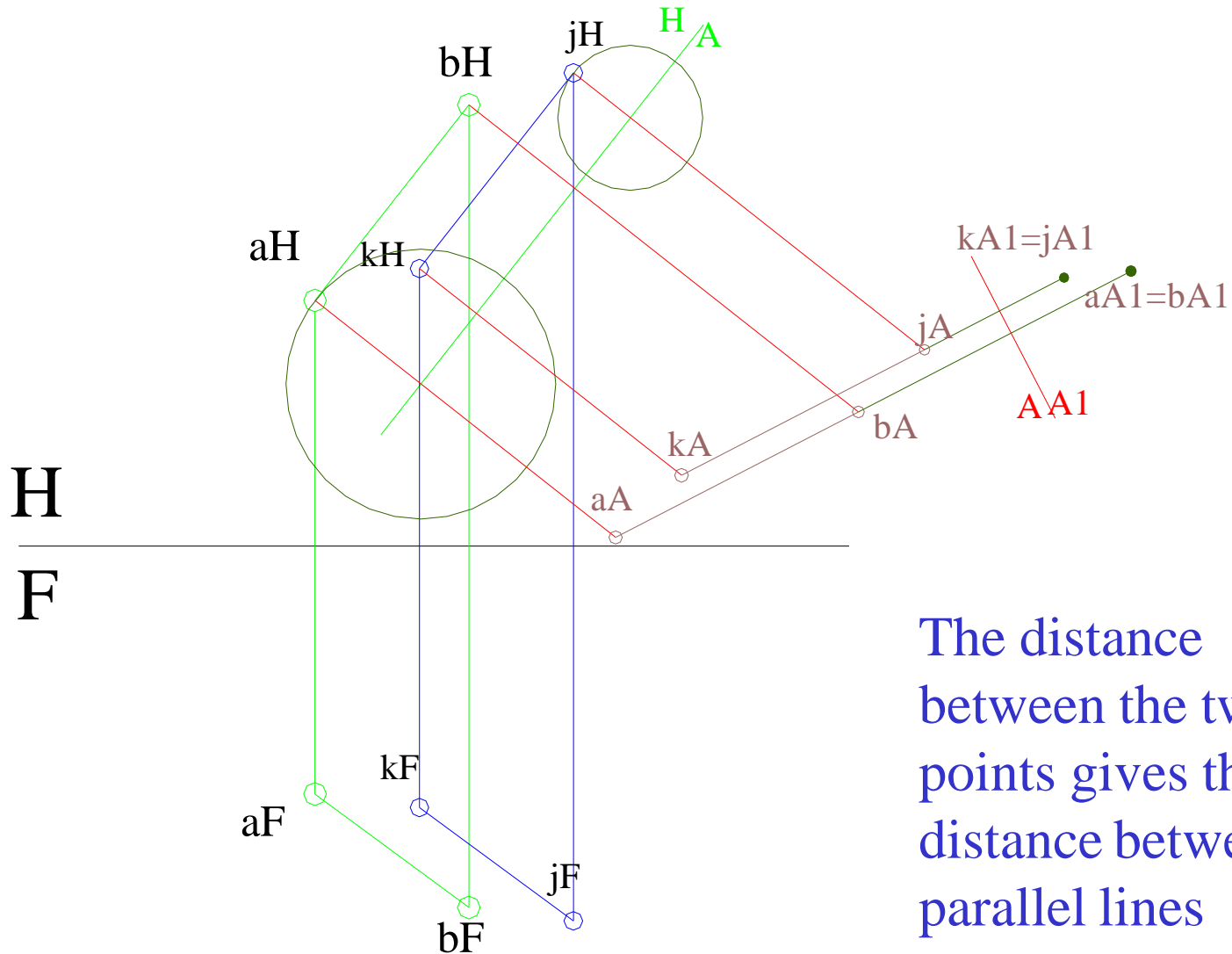

The distance between the two points gives the true distance between parallel lines

14. Intersecting lines

Intersection test:
Locate a point that
belongs to both lines

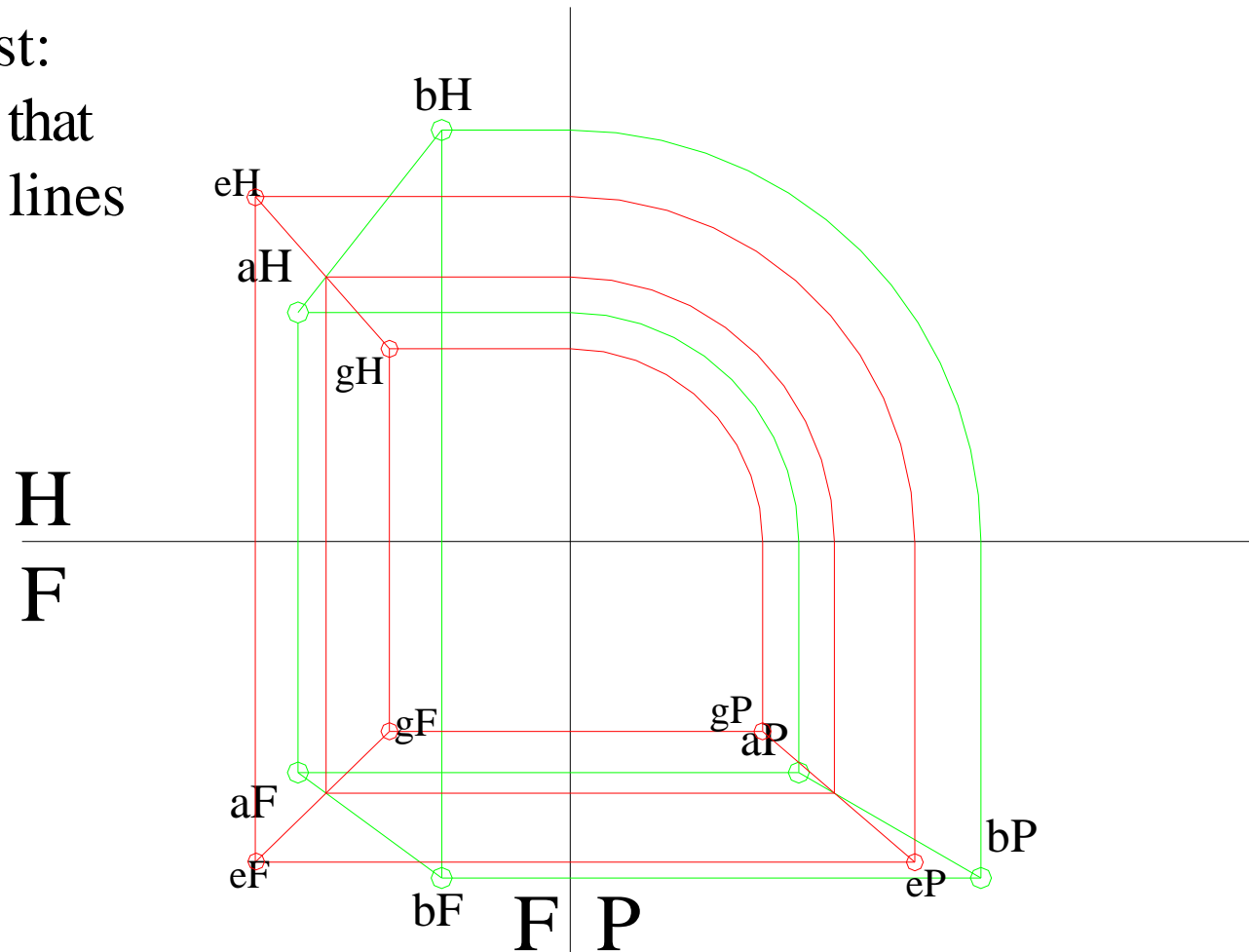

15. Perpendicular lines

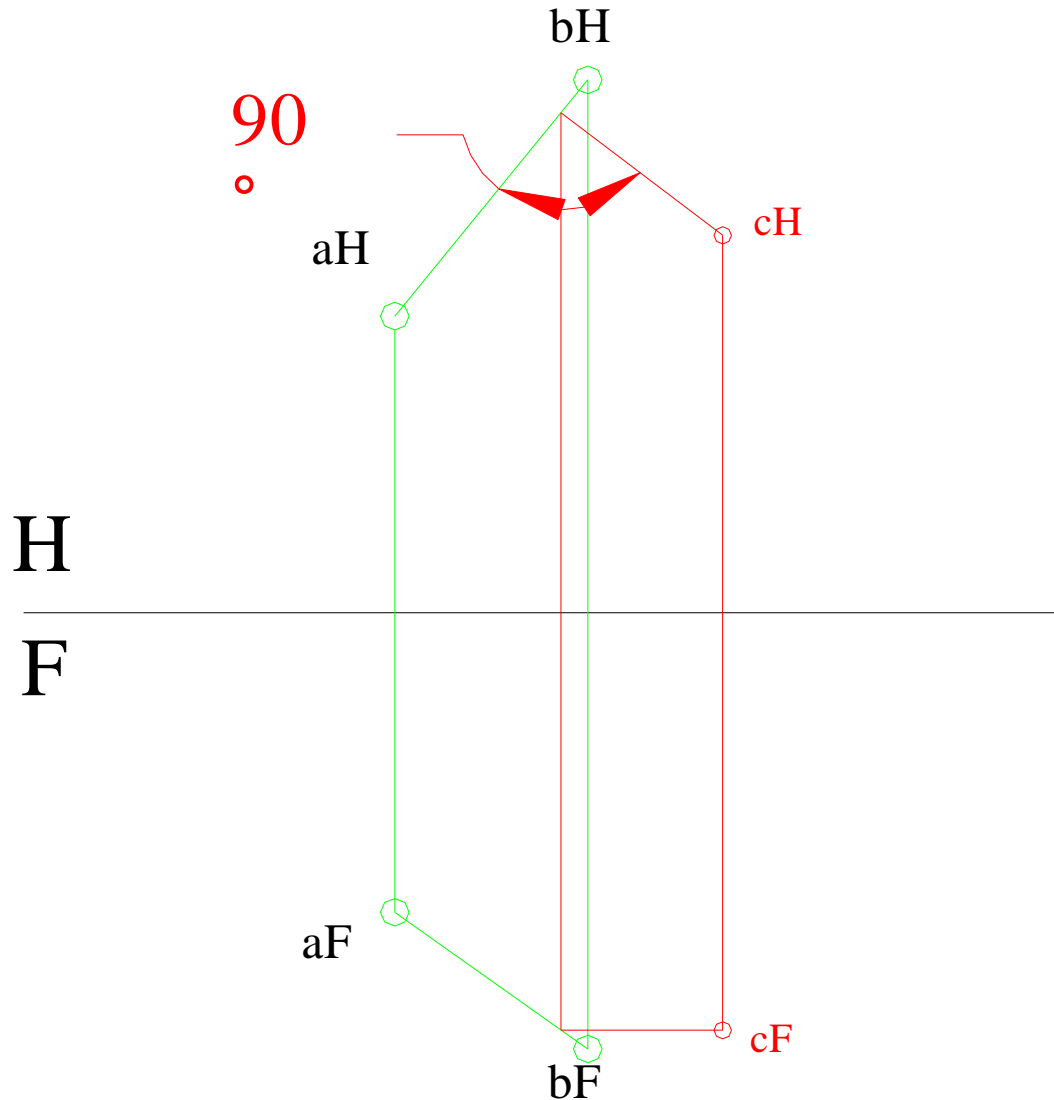

A 90° angle appears in true size in any view showing one leg in TL provided the other leg does not appear as point view

Two intersecting lines are perpendicular if the TL projection is making 90° with the other line

15. Perpendicular lines

