

MECH 211 – Mechanical Engineering Drawing

François Tardy
Credits: 3.5

Lecture 6

Lecture Objectives – Continued

To continue to acquire knowledge in the Descriptive Geometry – point and line and plane concepts:

- Dip of a plane == Slope of a **plane**
- Shortest line from a point to a **plane** – EV of the plane
- Shortest grade line from a point to a **plane** – EV of a plane in elevation view
- True size (shape) of a **plane**
- Angle between two intersecting lines – **plane** method
- Location of a line through a given point intersecting a given line to a given angle – **plane** method
- Location of a **plane** through a point parallel to two lines
- Shortest grade line between two skew lines – **plane** method

Lecture Objectives – Continued

To continue to acquire knowledge in the Descriptive Geometry – point and line **and plane** concepts:

- Relative position of a line to a **plane**
- Line parallel to a **plane**
- Line intersecting a **plane**
- Line perpendicular to a **plane**
- Intersection of two **planes** – EV method
- The cutting plane method – intersection of a line with a **plane**
- Intersection of two **planes** – CP method

Slope (dip) of a plane

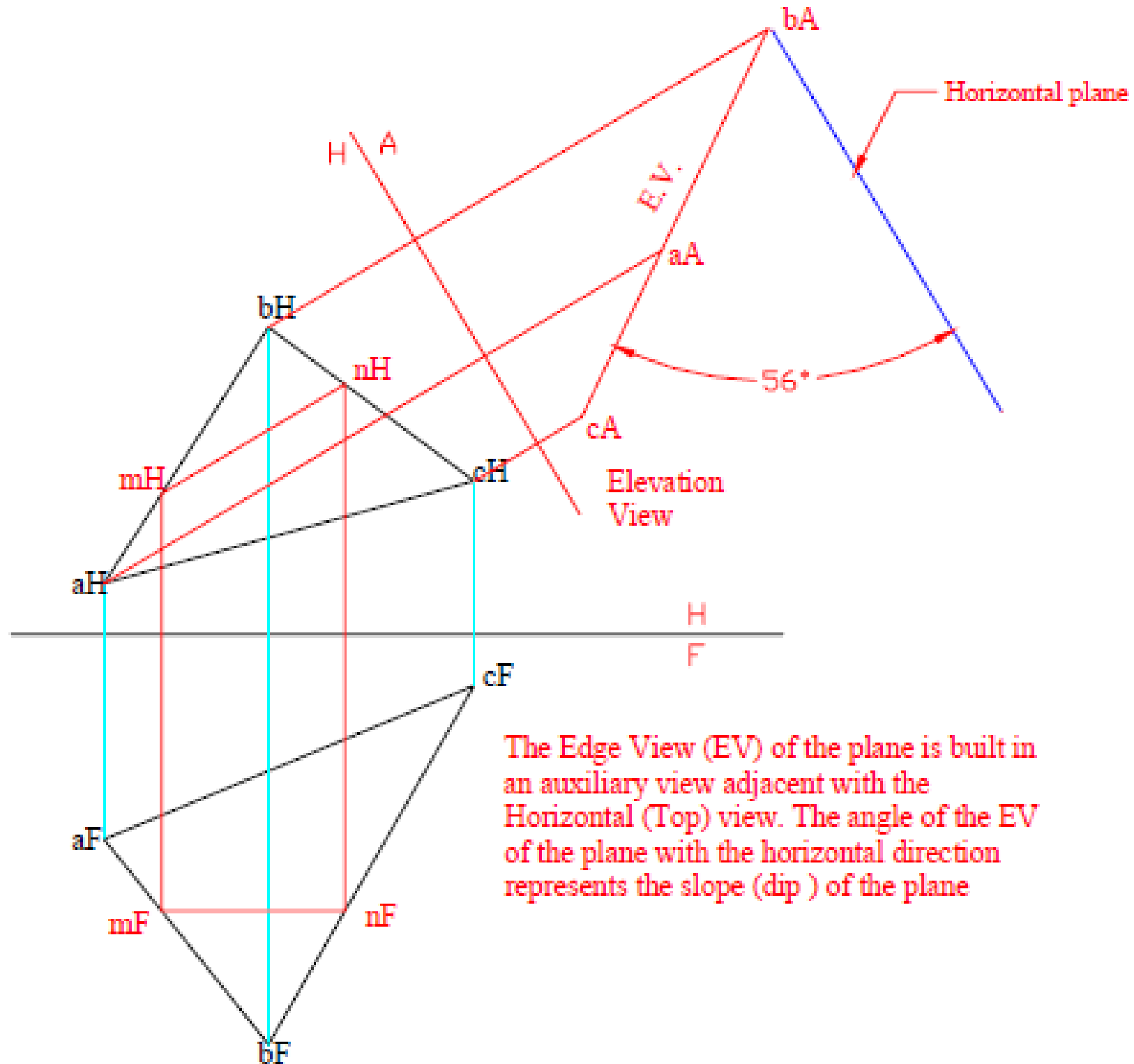

Shortest line from a point to plane

To find the shortest line
from point to plane.

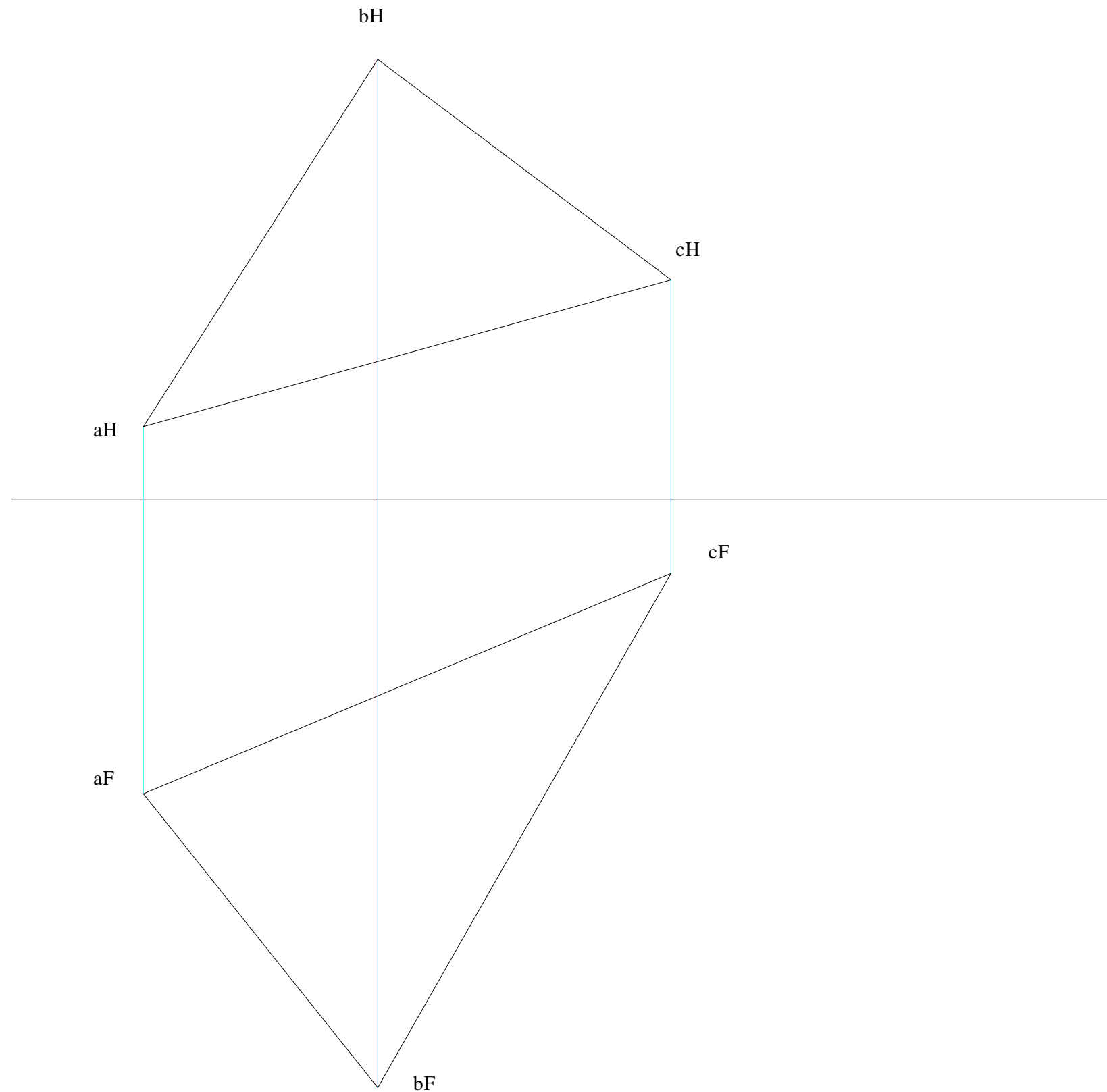

Shortest line from a point to plane

Find the EV of the plane

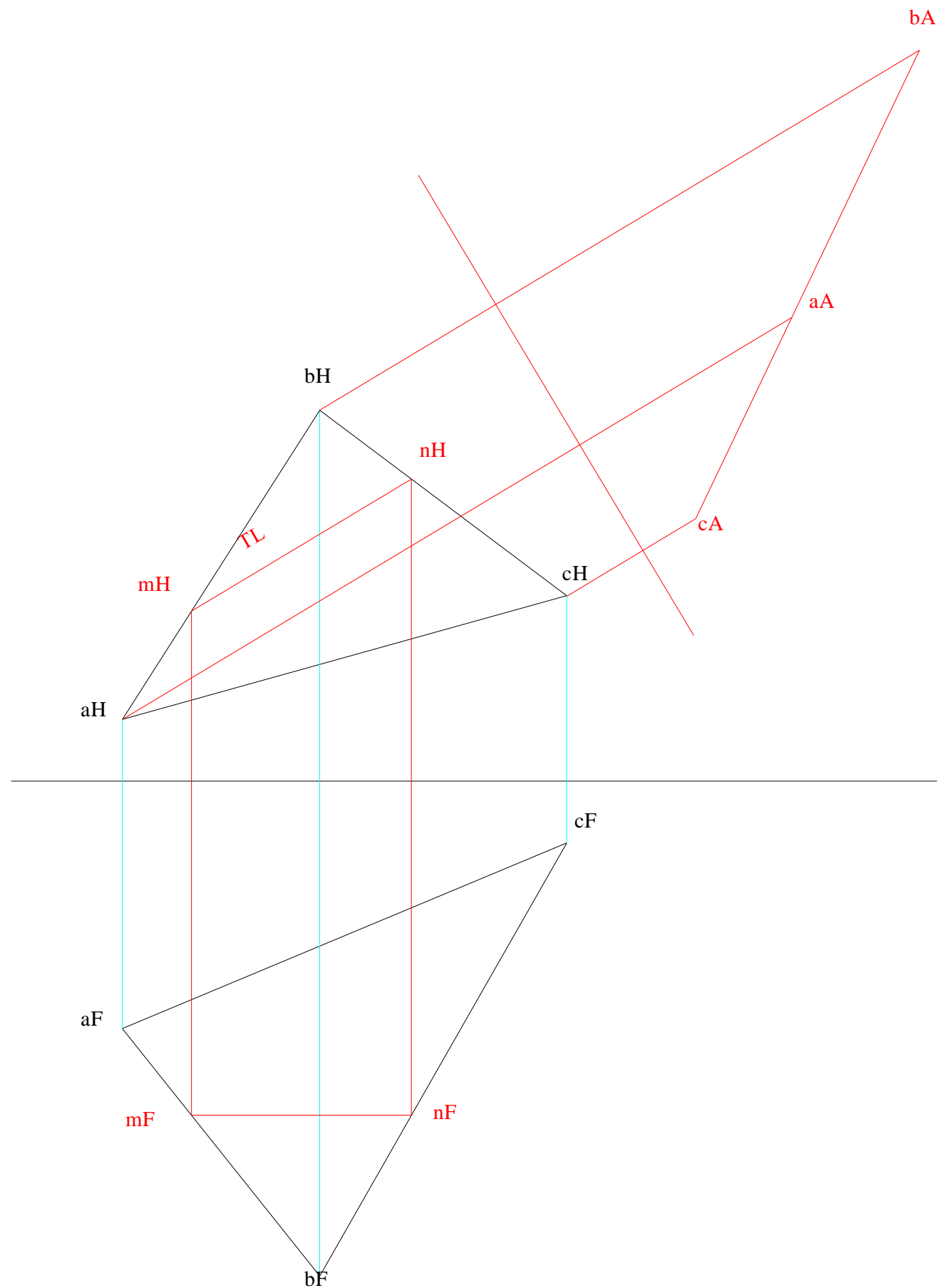

Shortest line from a point to plane

Find the EV of the Plane.

Project the point in that view.

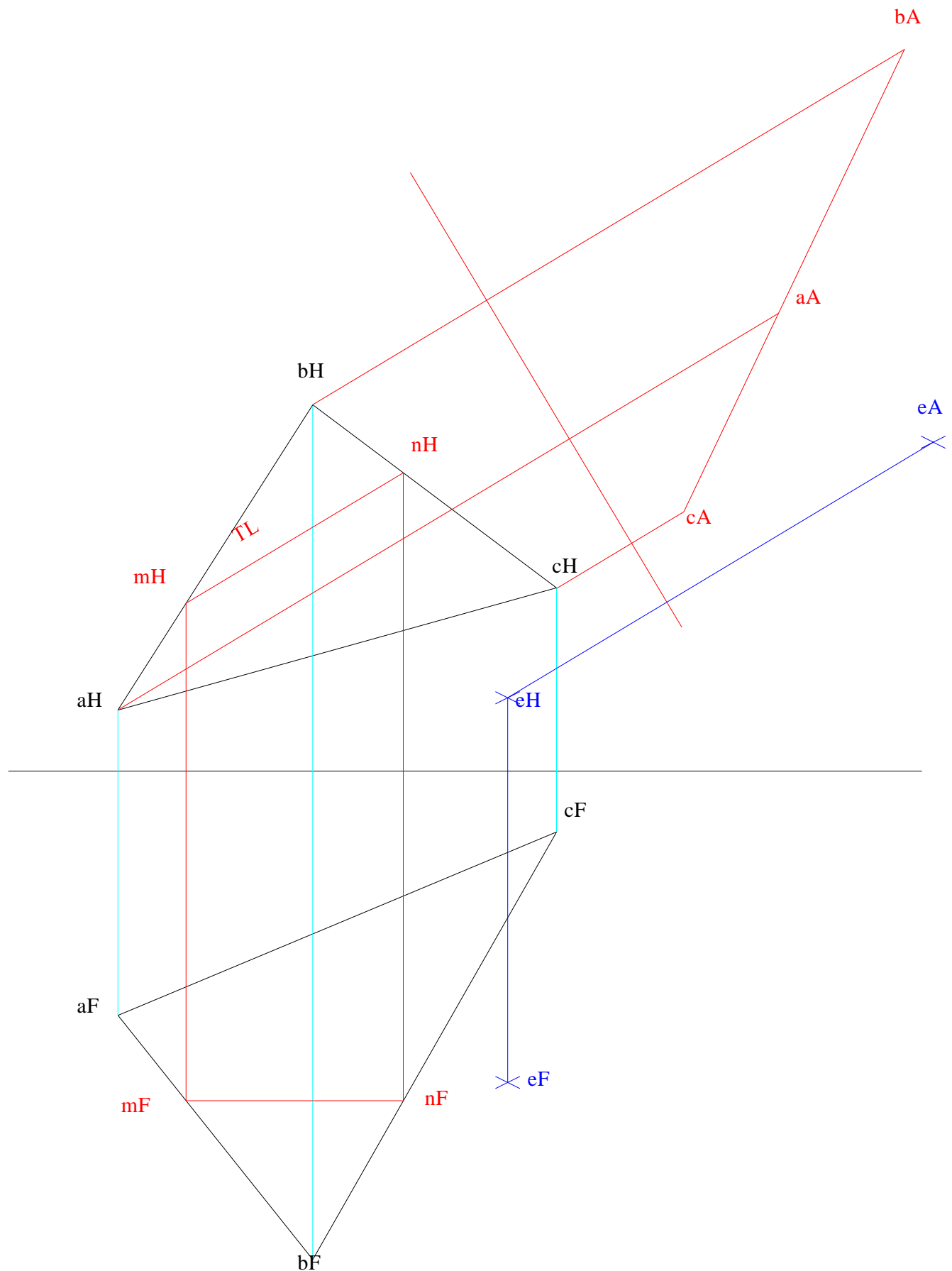

Shortest line from a point to plane

Find the EV of the plane.

Project the point in that View.

Draw perpendicular from point to EV.

Traceback with perp from TL in the HV

For FV use distance

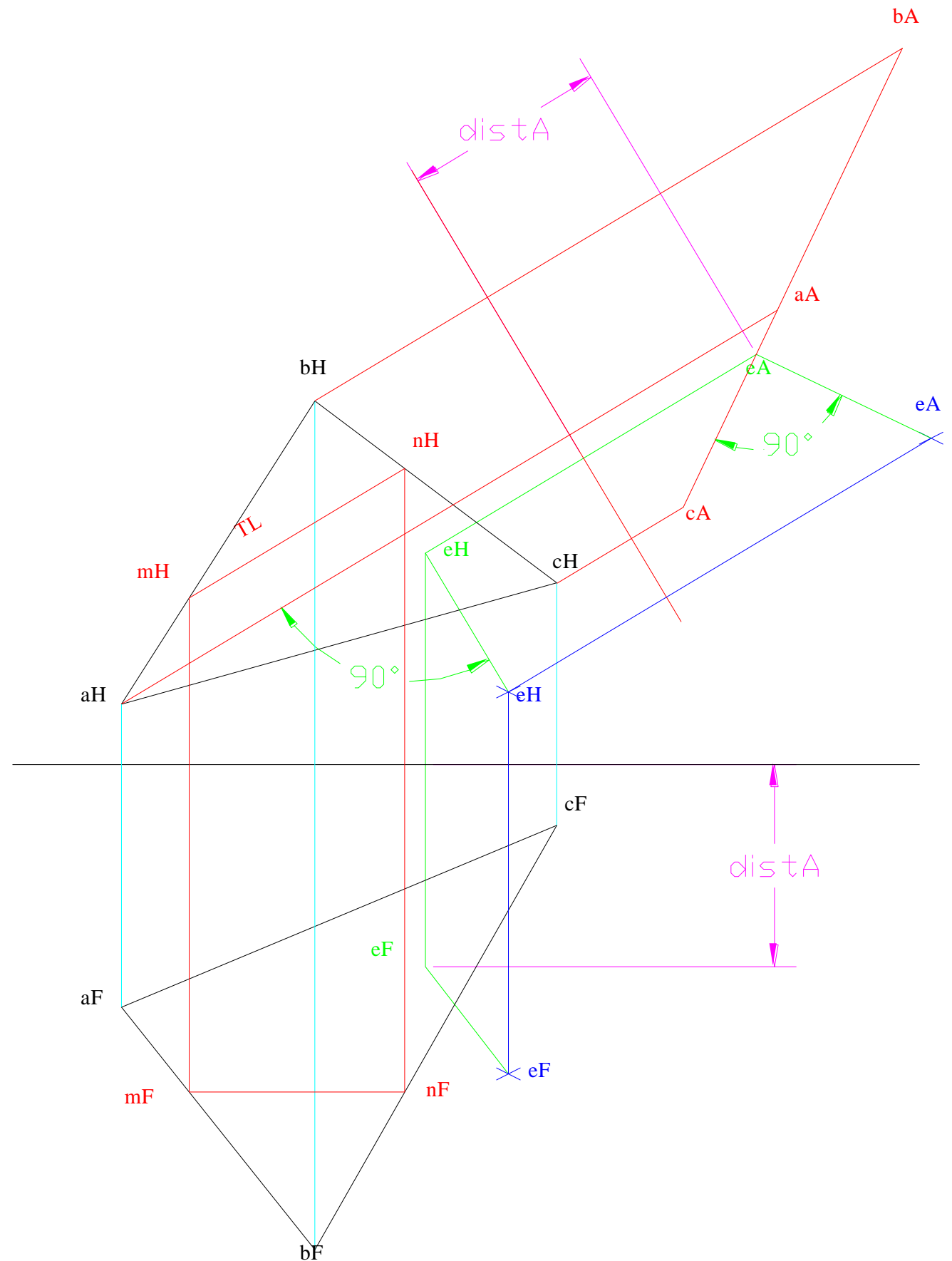

Shortest grade line - point to plane

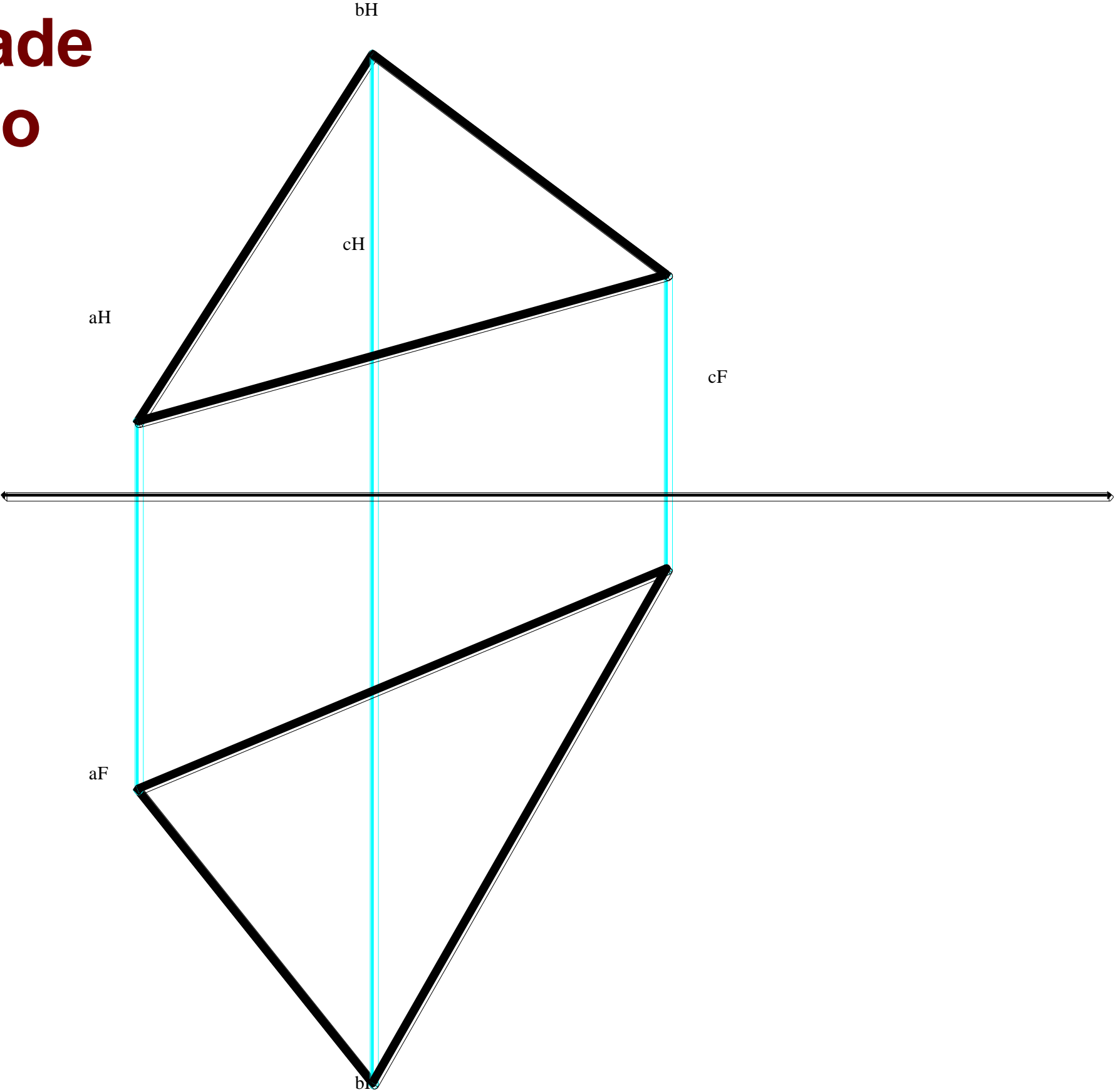

Shortest grade line - point to plane

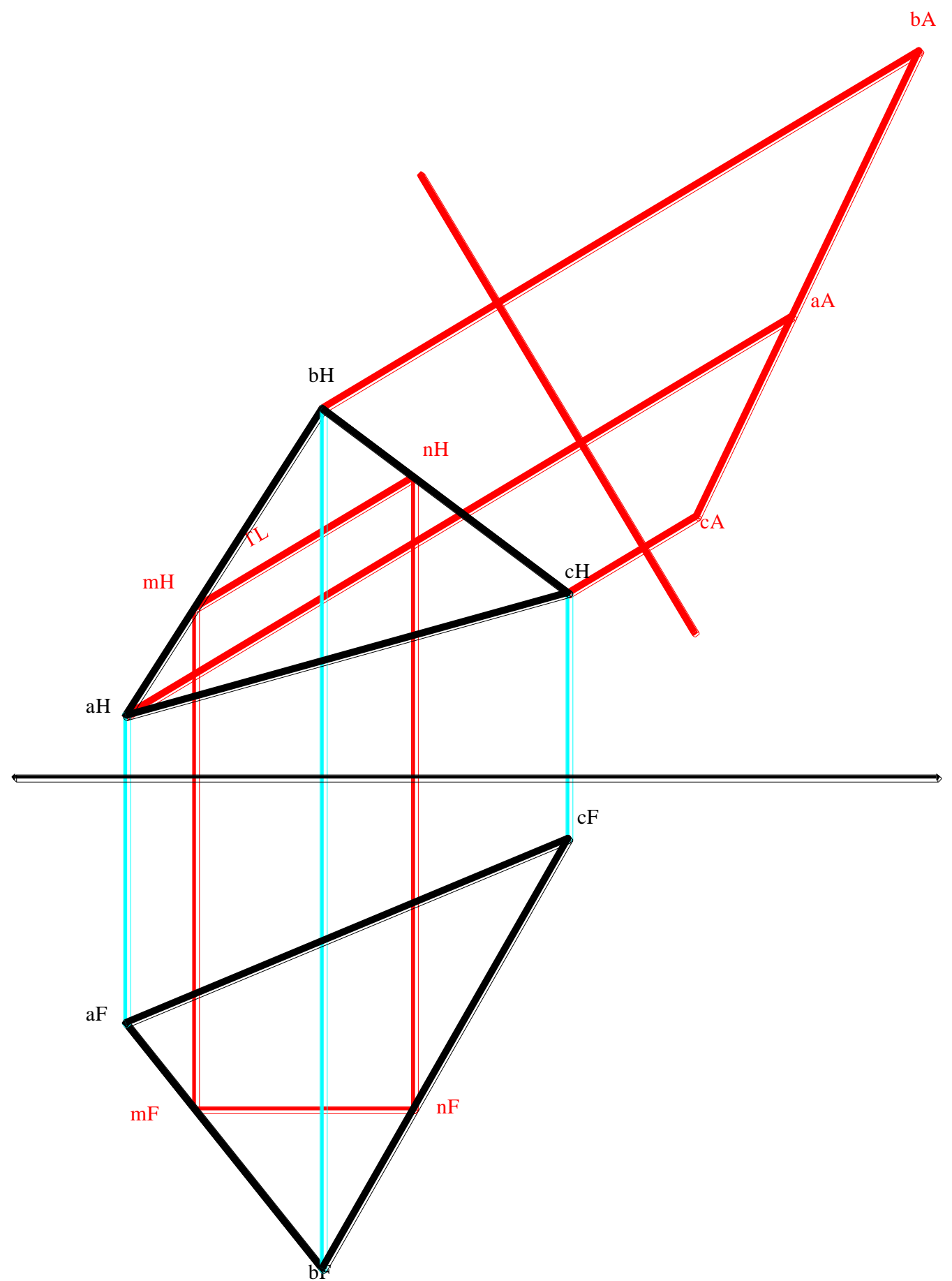

Shortest grade line - point to plane

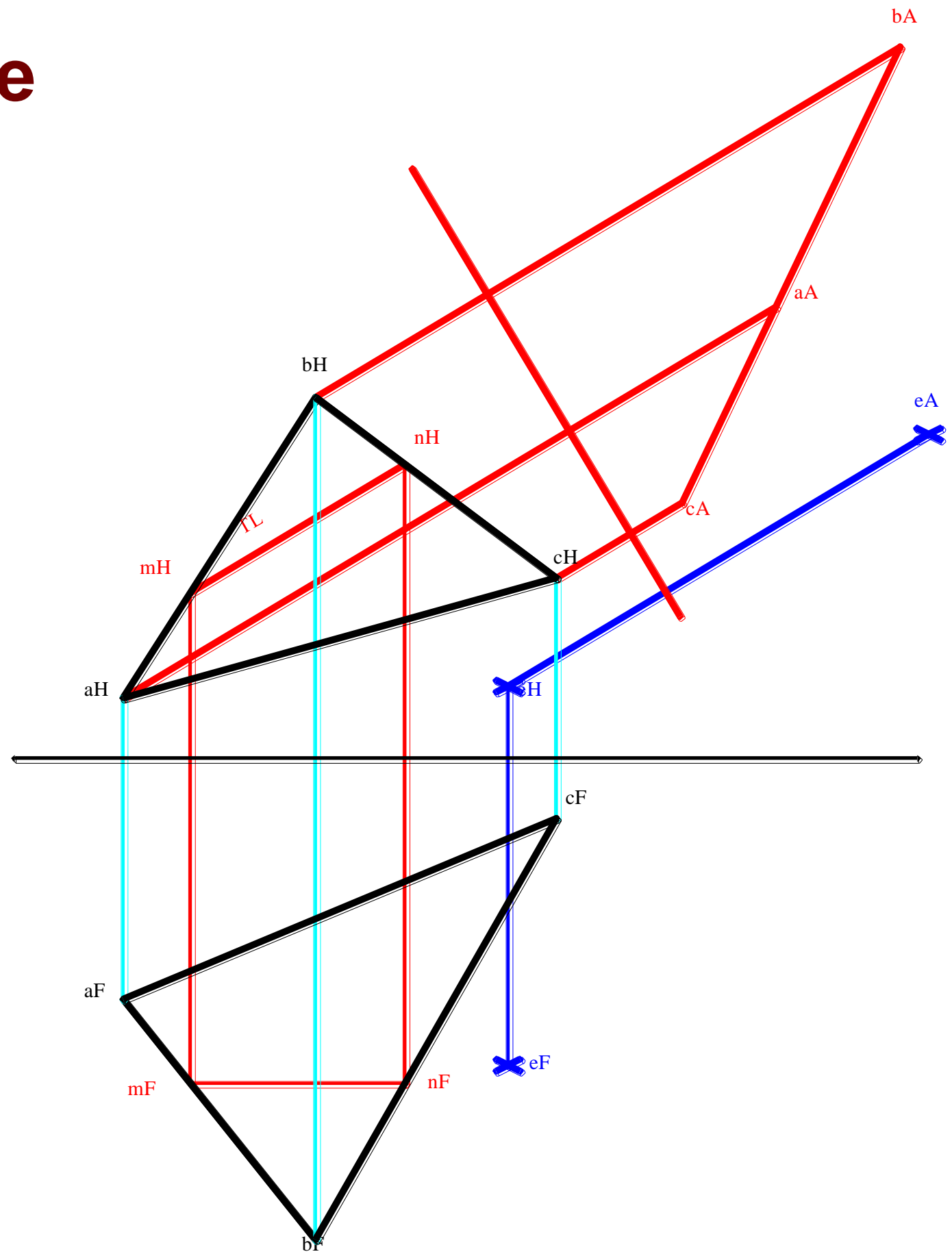

Shortest grade line - point to plane

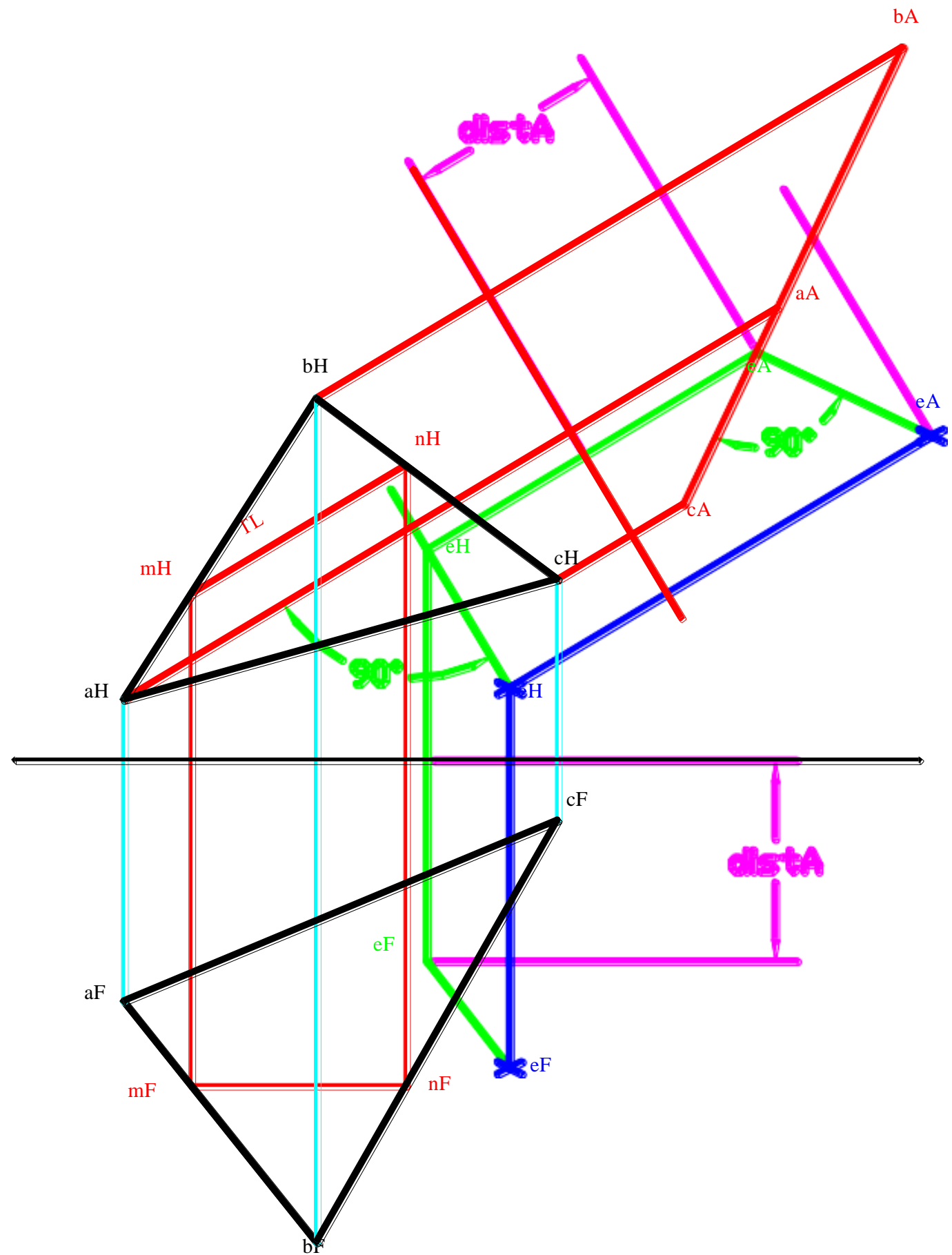

Shortest grade line - point to plane

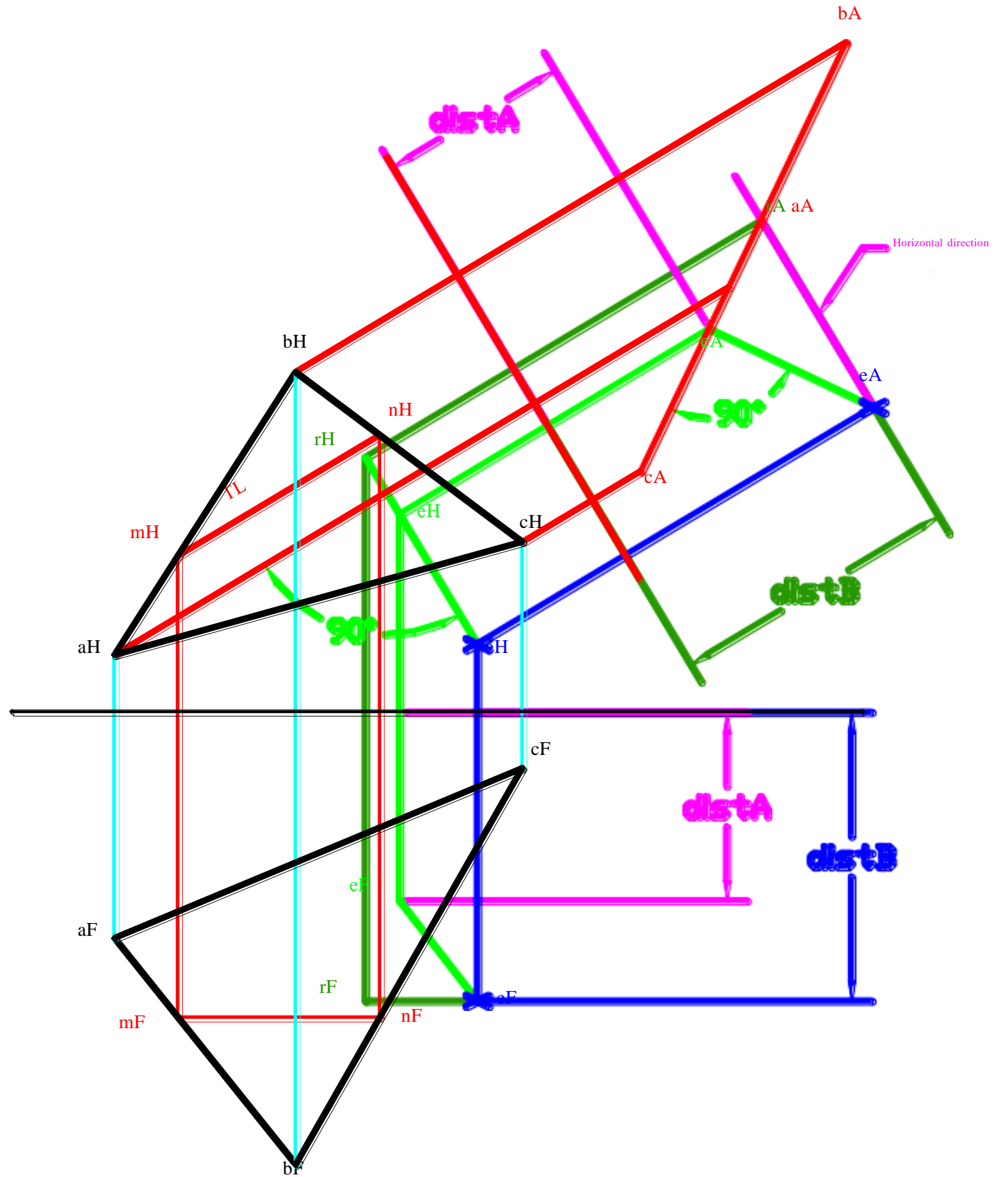

Shortest grade line - point to plane

The slope could be shown ONLY IN AN ELEVATION VIEW

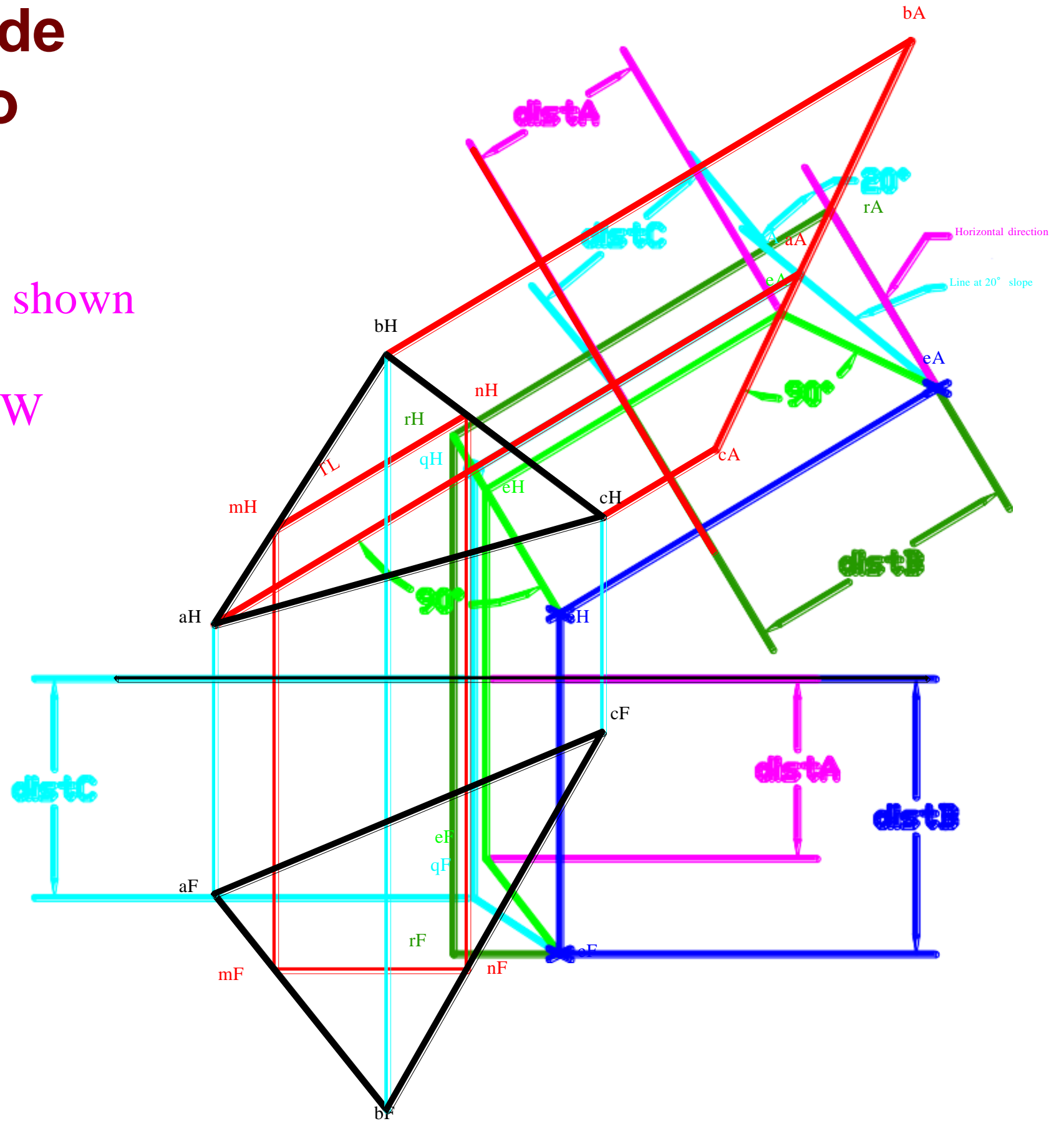

Shortest grade line from a point to a plane

The slope could be shown ONLY IN AN ELEVATION VIEW

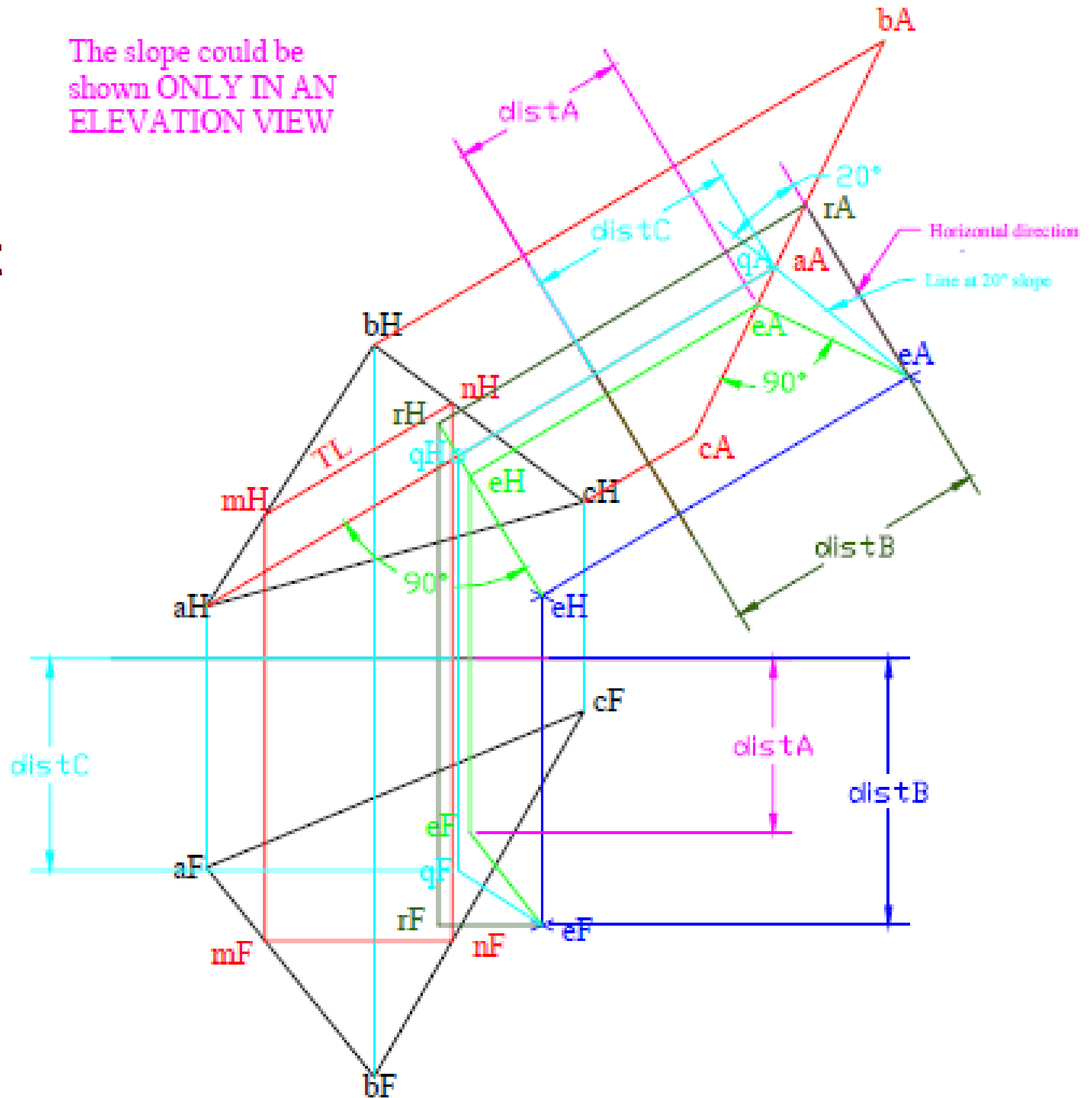

True Shape of Plane

True Shape of a Plane (TSP) is seen in the second auxiliary view, adjacent to the EV of the plane.

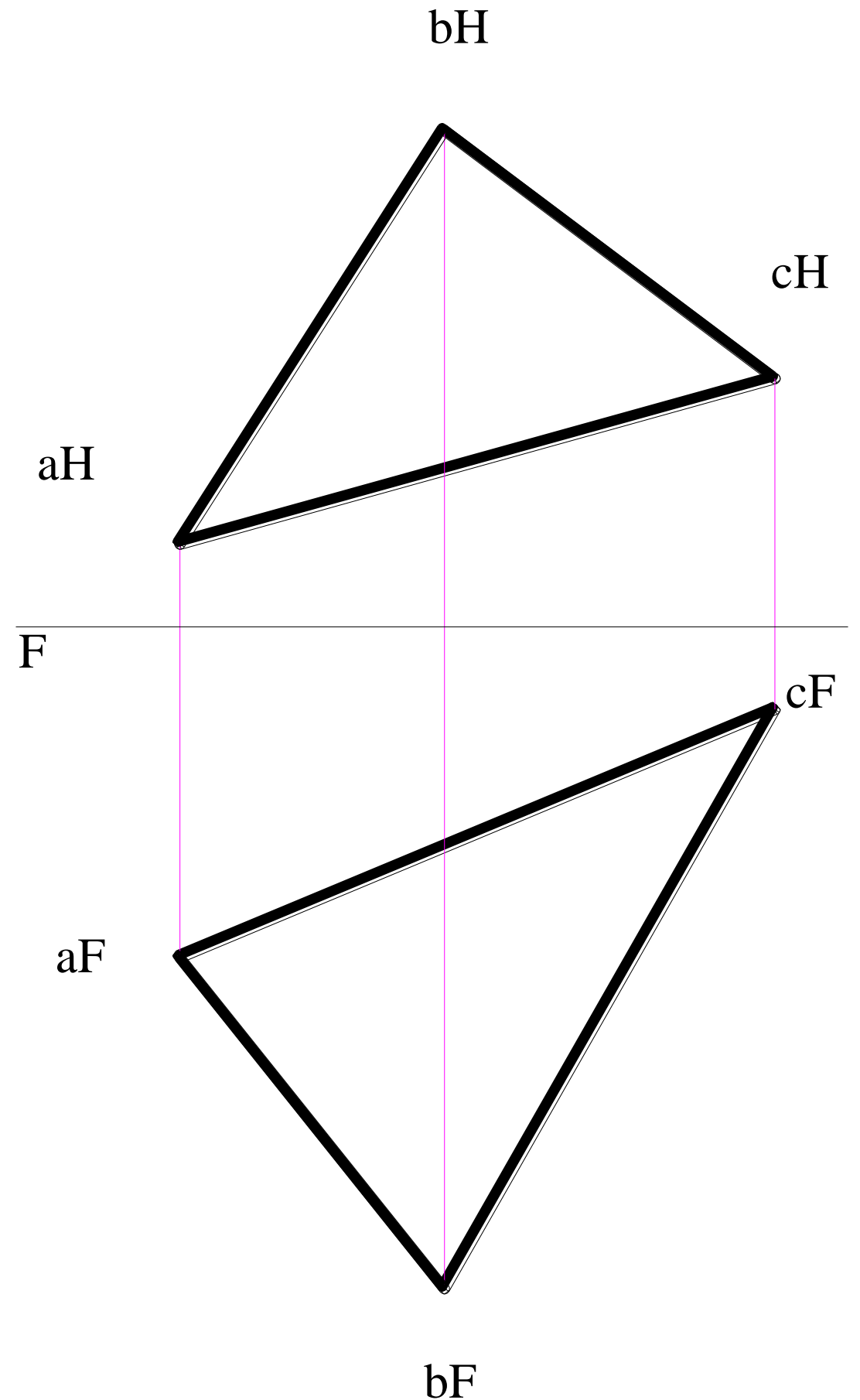

True Shape of Plane

True Shape of a Plane (TSP) is seen in the second auxiliary view, adjacent to the EV of the plane.

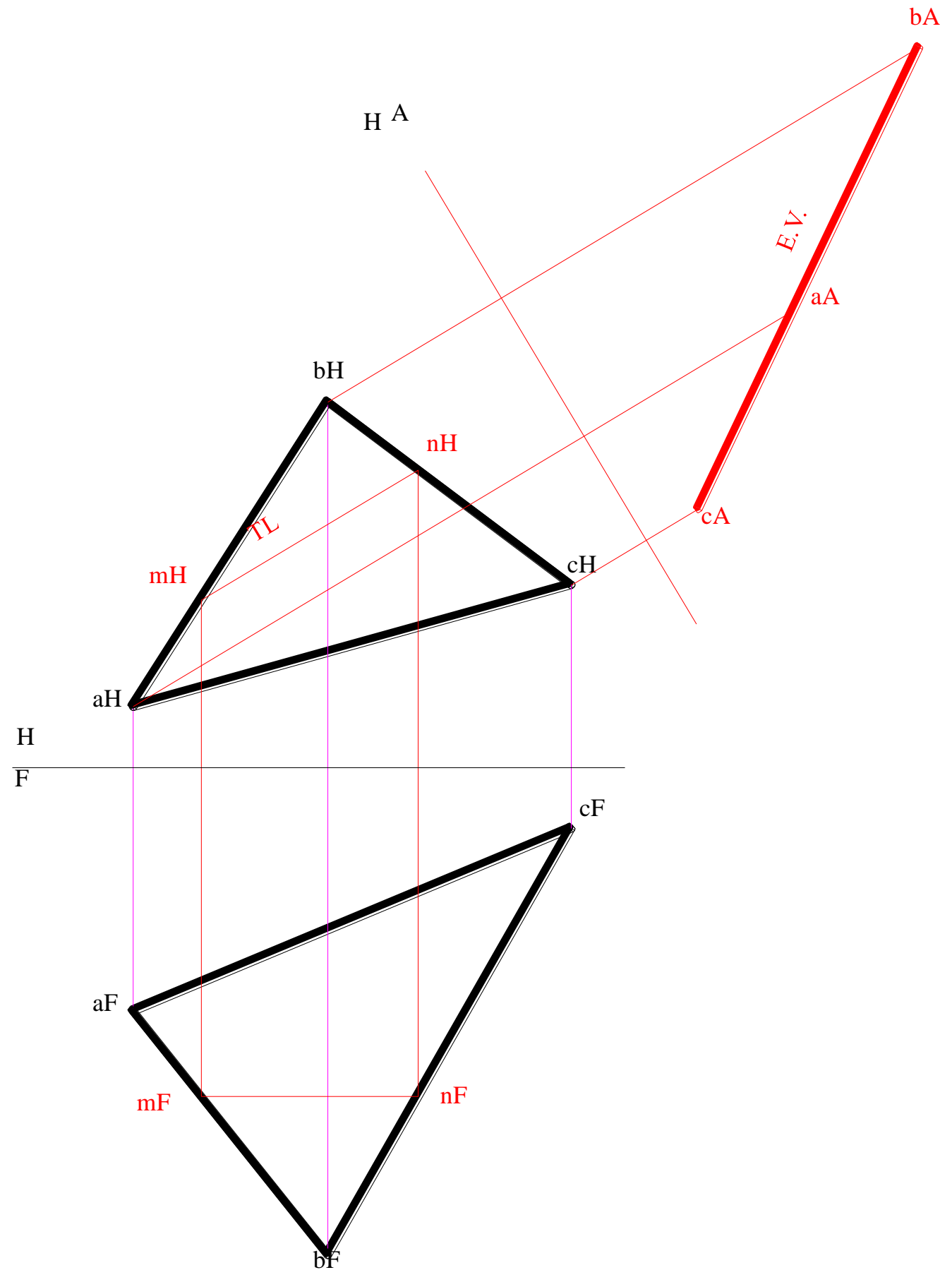

True Shape of Plane

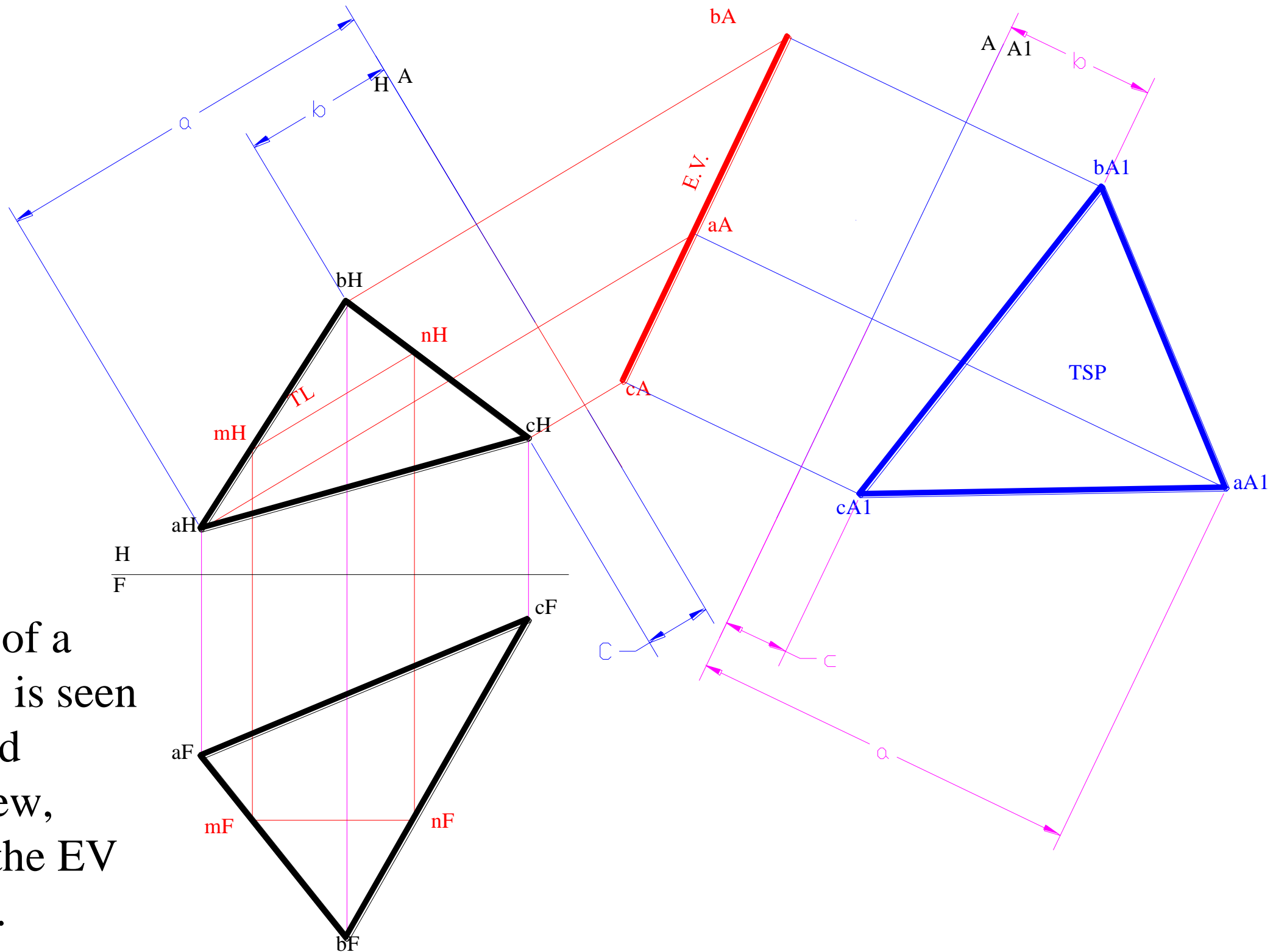

True Shape of a Plane (TSP) is seen in the second auxiliary view, adjacent to the EV of the plane.

True shape of a plane

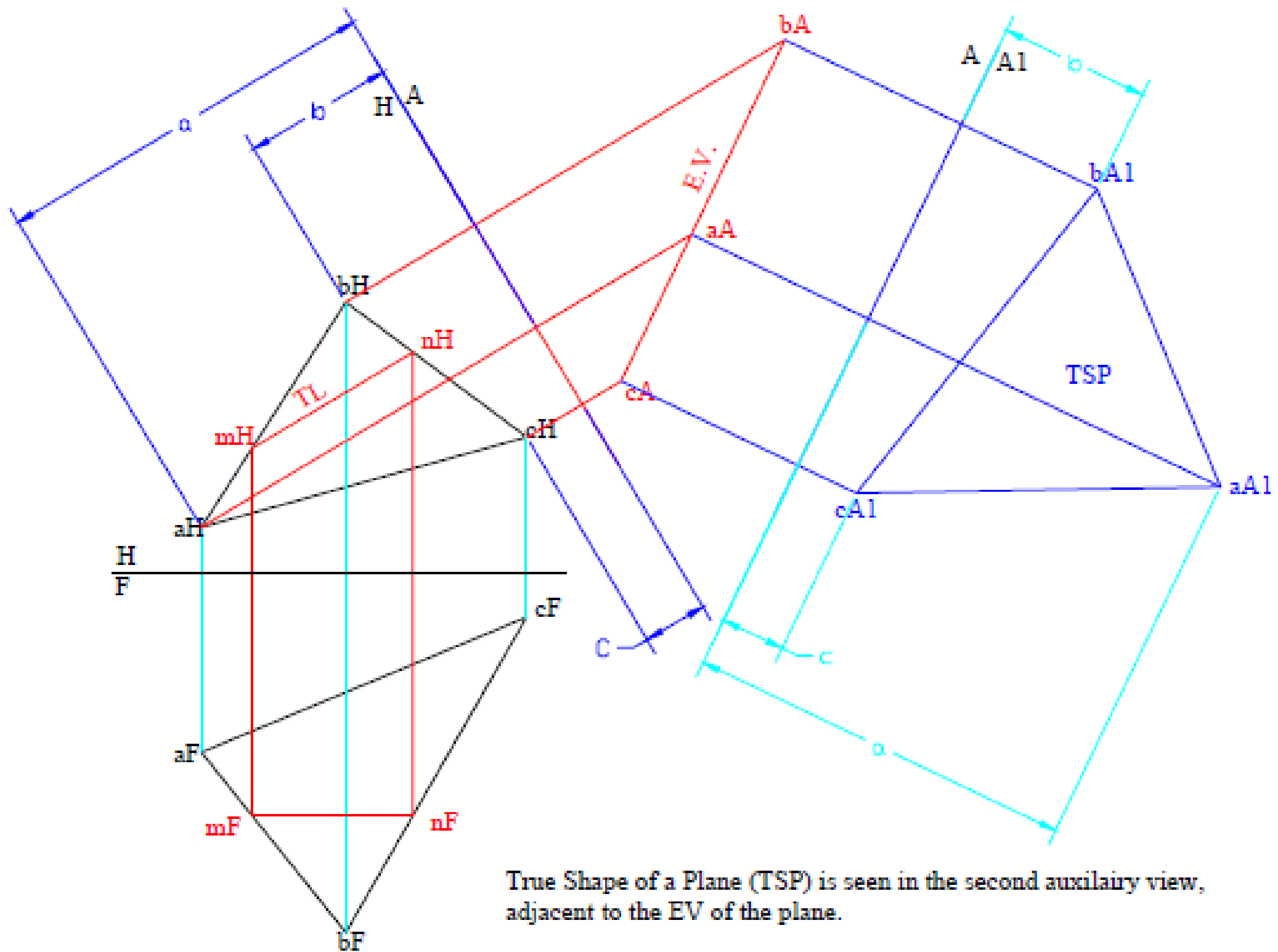

True Shape of a Plane (TSP) is seen in the second auxiliary view, adjacent to the EV of the plane.

True Shape of Plane

Used to find the centre of a circle in an oblique plane.

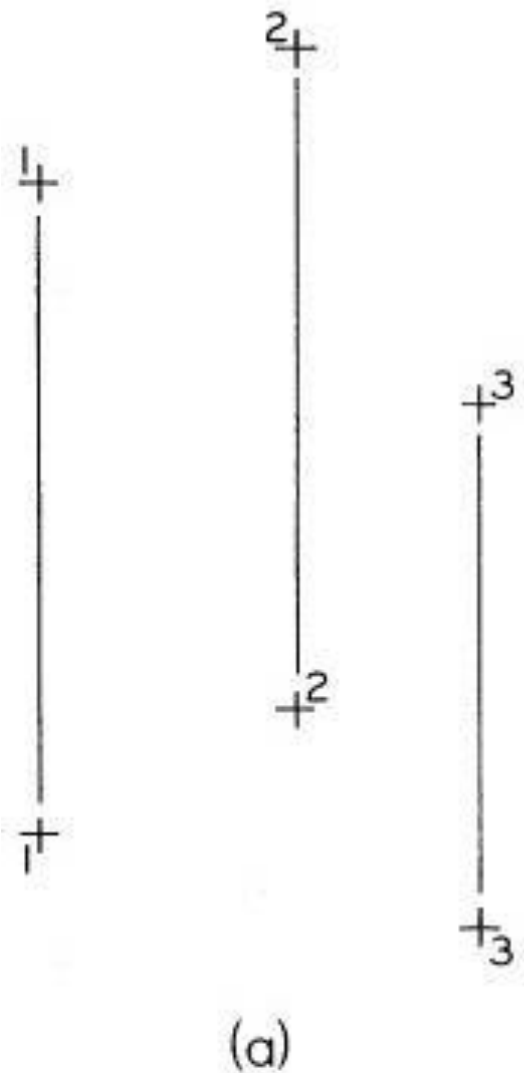

True Shape of Plane

Application, to find centre of circle in an oblique plane.

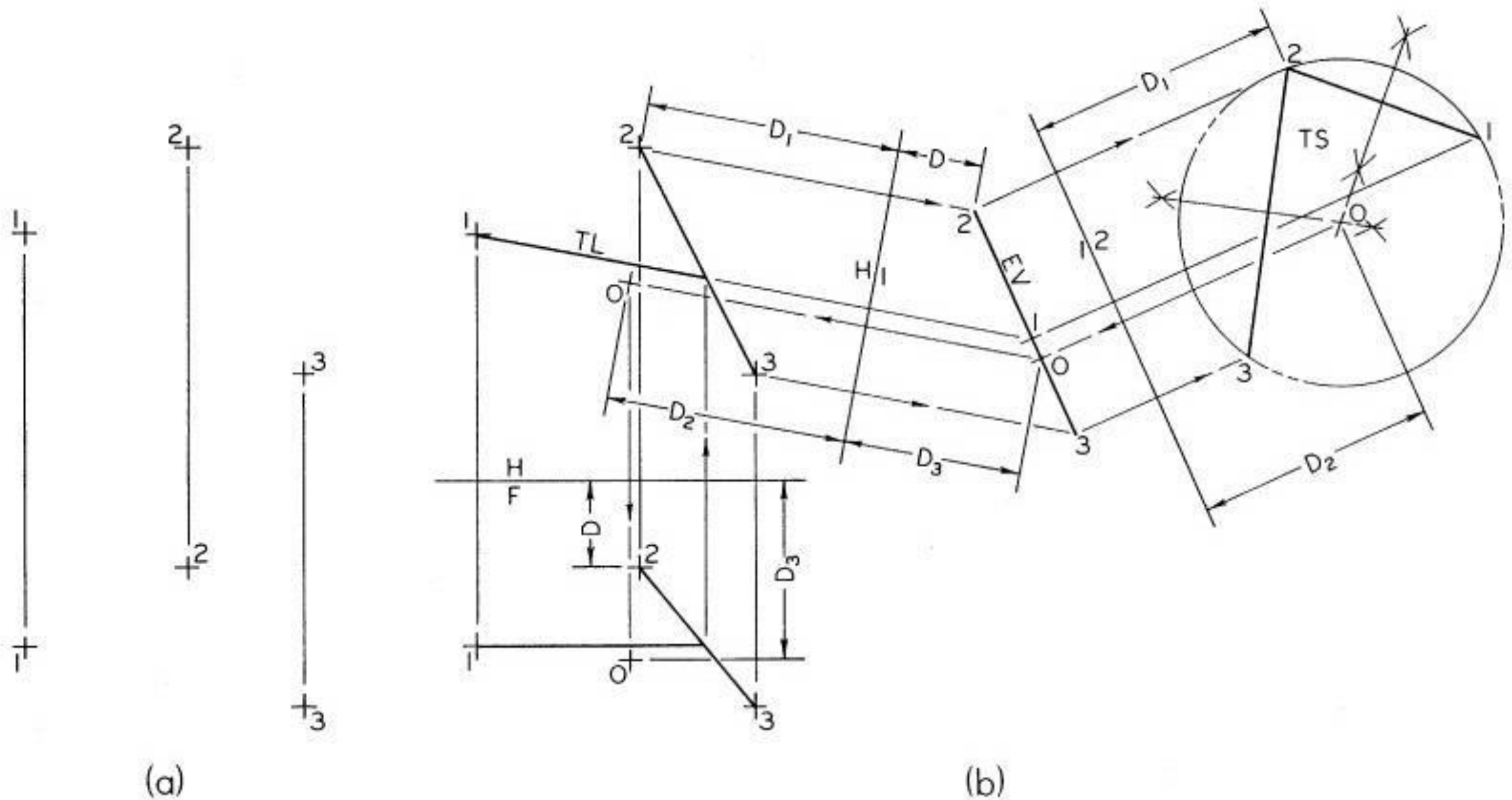

Angle of Line with Oblique Plane

The angle of a line with an oblique plane is seen when the line is seen in true length and the plane in edge view.

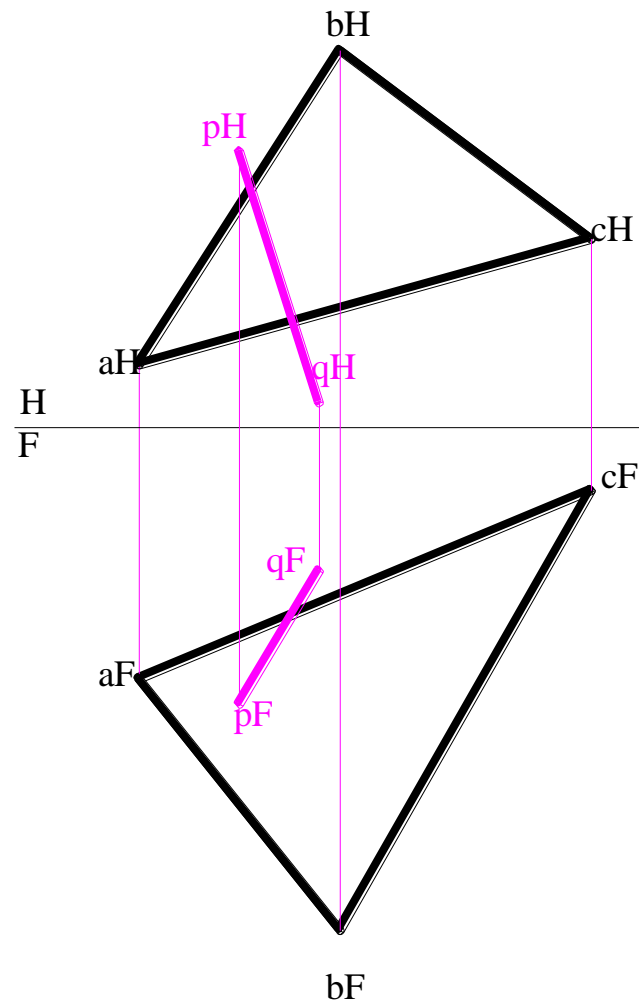

Angle of Line with Oblique Plane

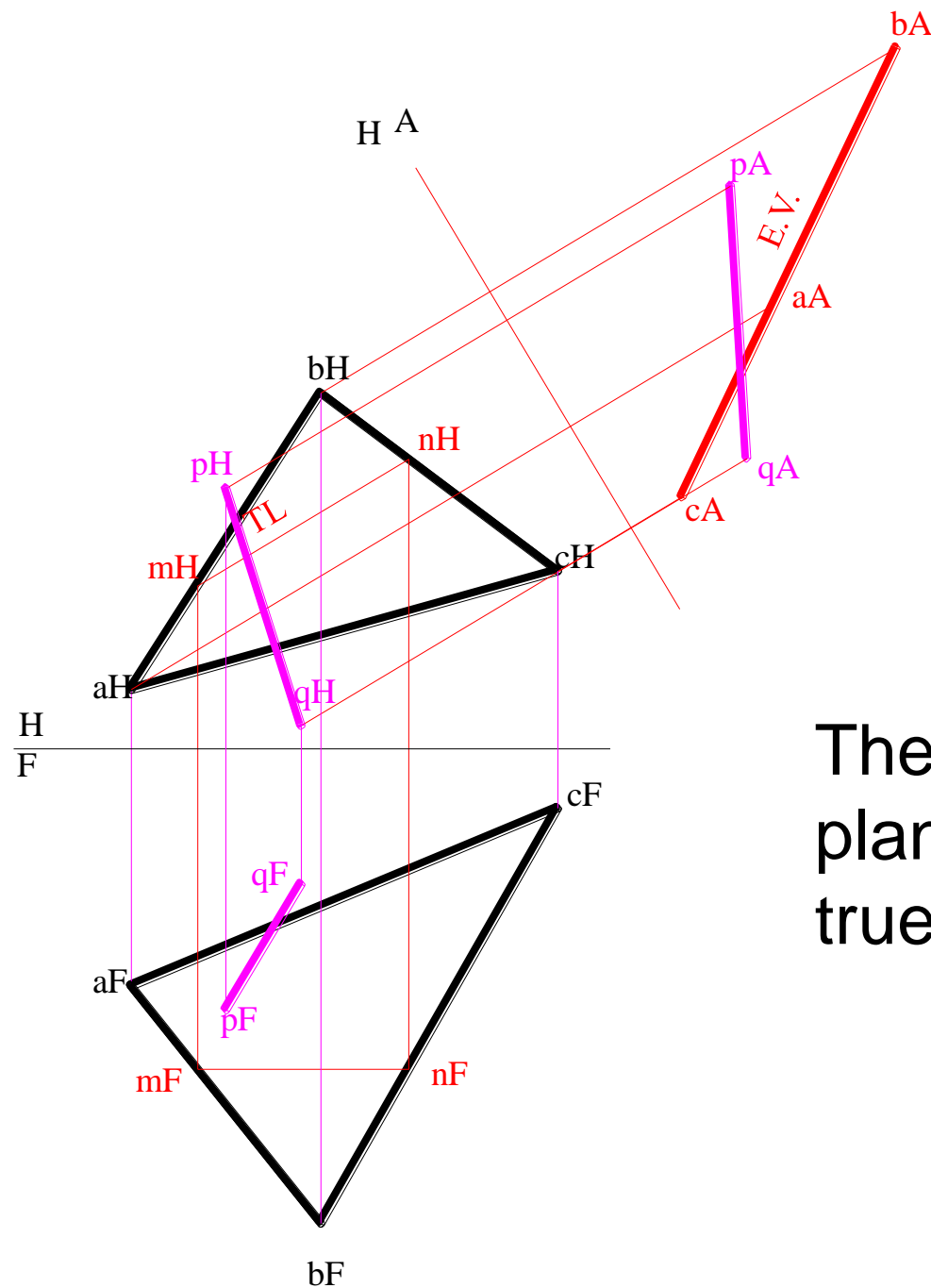

The angle of a line with an oblique plane is seen when the line is seen in true length and the plane in edge view.

Angle of Line with Oblique Plane

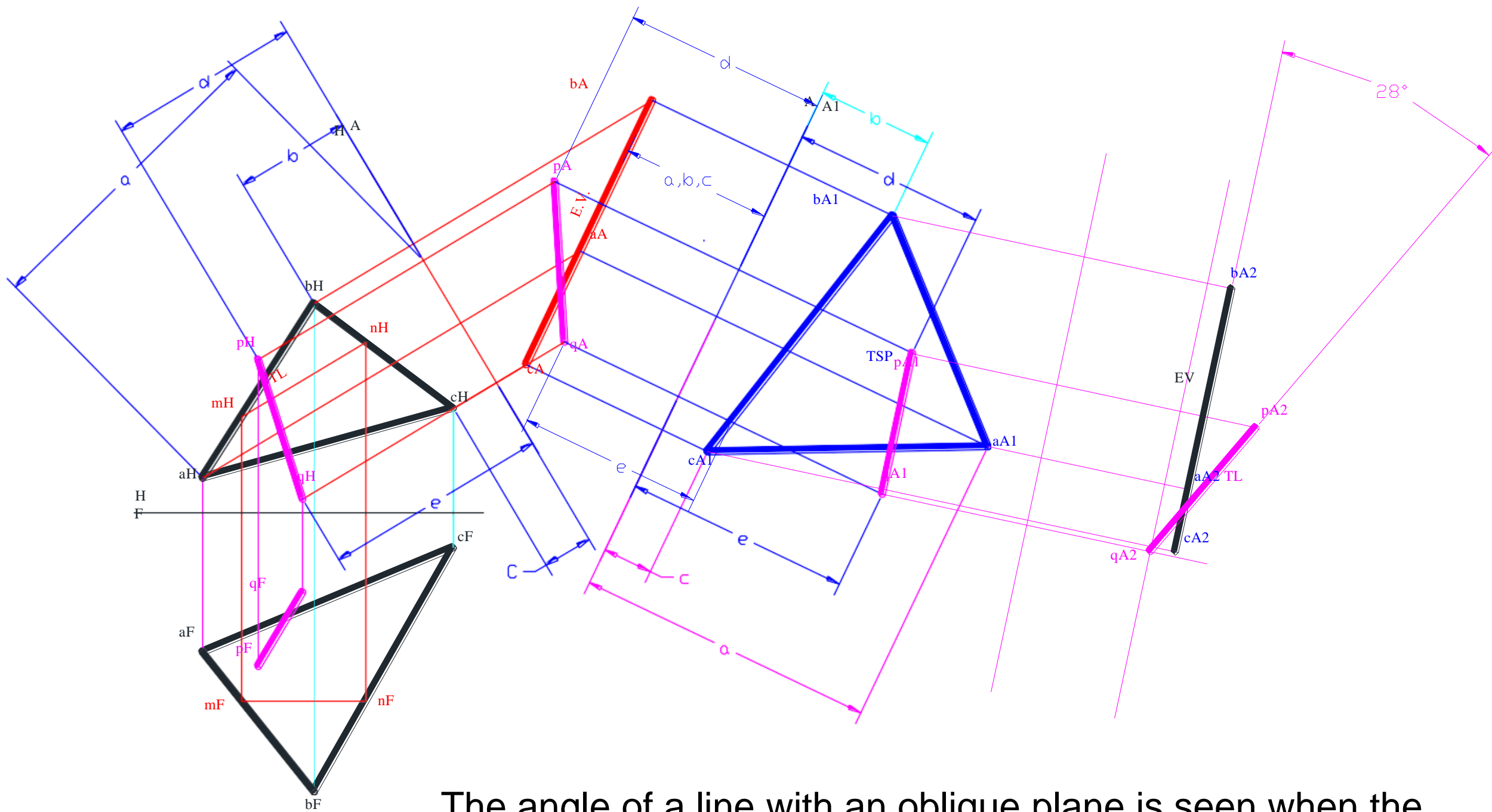

The angle of a line with an oblique plane is seen when the line is seen in true length and the plane in edge view.

Angle Between Intersecting Lines

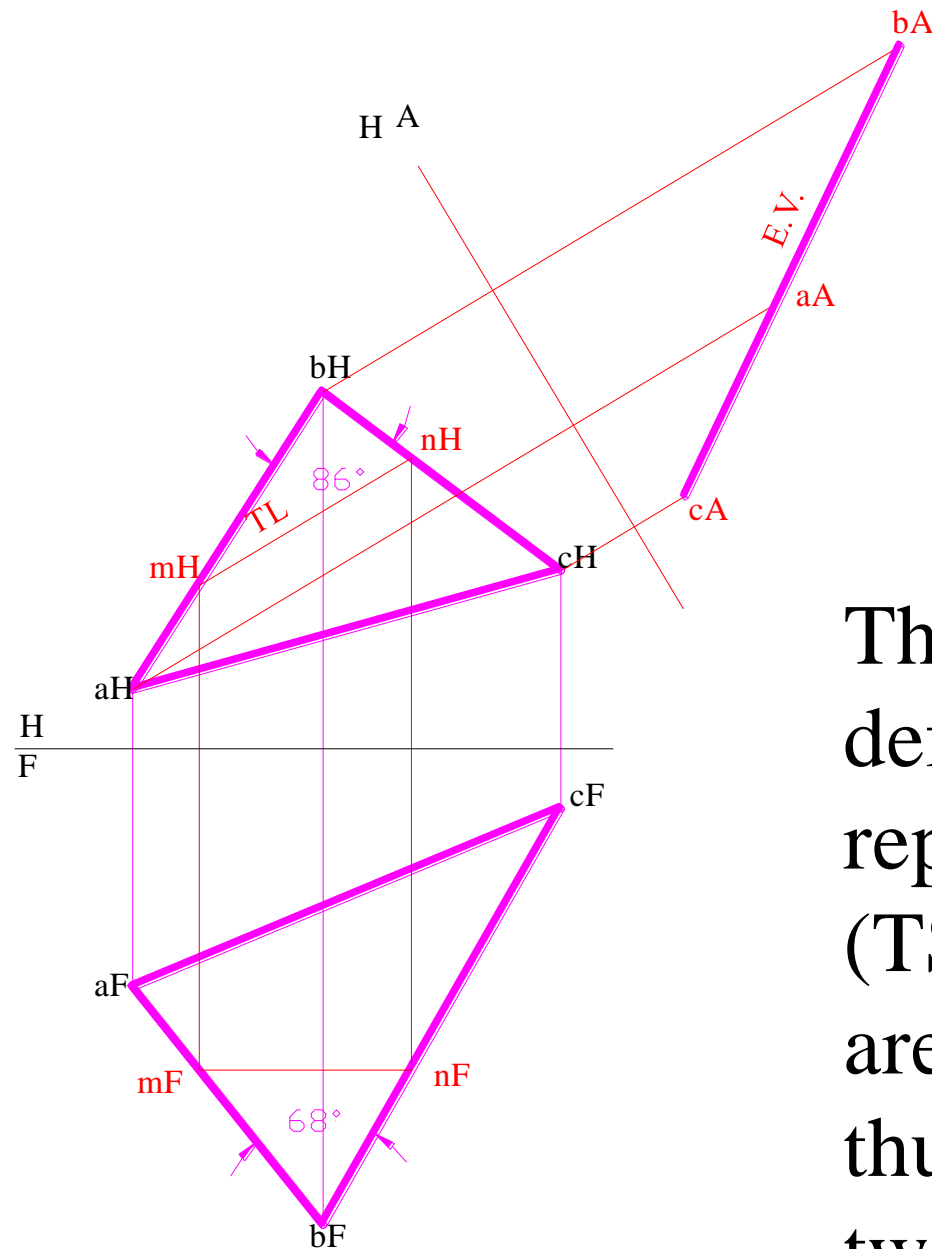

The two lines, AB and BC, define a plane that is represented as a true shape (TS). In that plane, the angles are seen as their real size and thus the angle between the two lines can be measured.

Angle Between Intersecting Lines

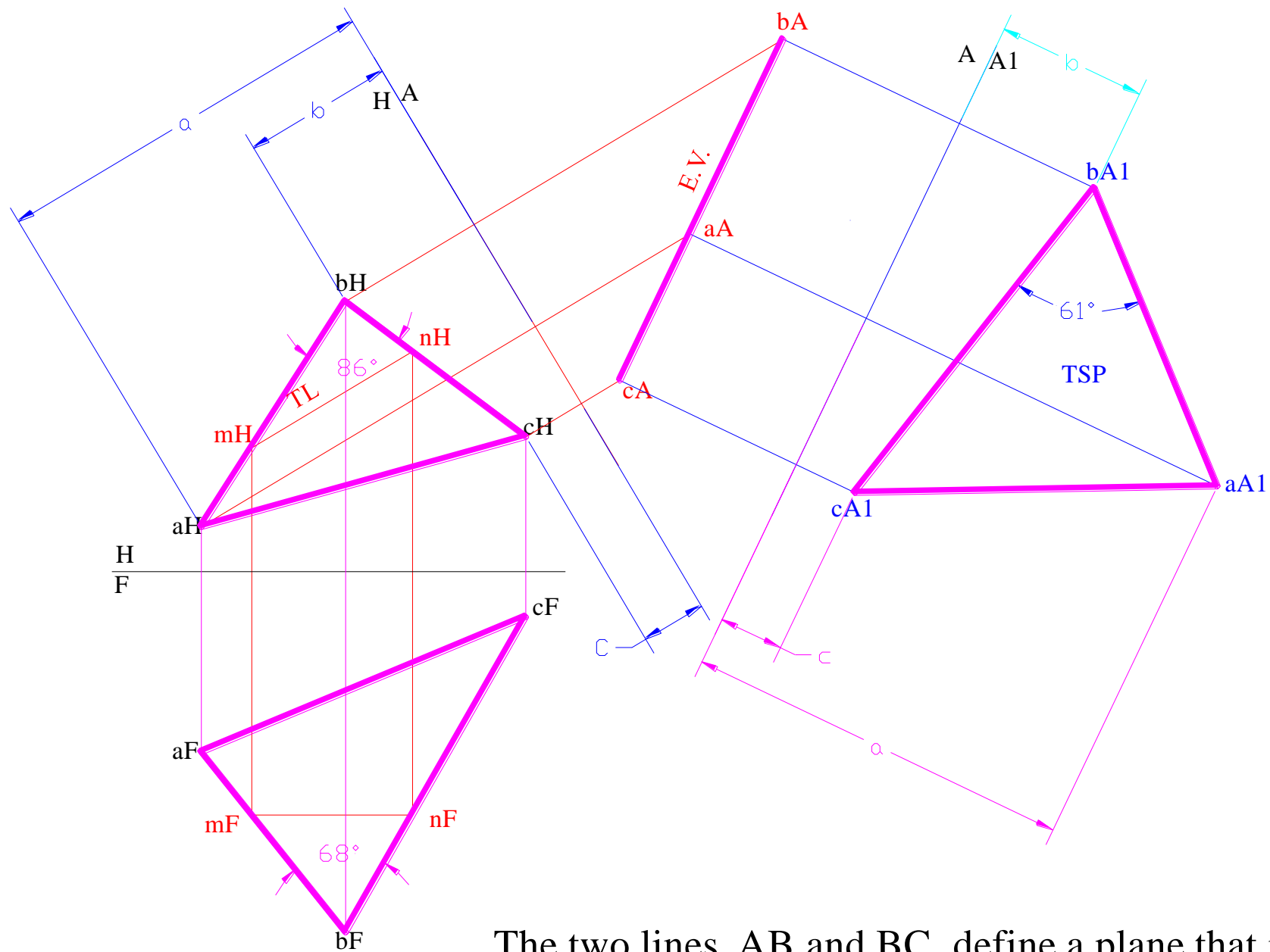

The two lines, AB and BC, define a plane that is represented as a true shape (TS). In that plane, the angles are seen as their real size and thus the angle between the two lines can be measured.

Angle between intersecting lines

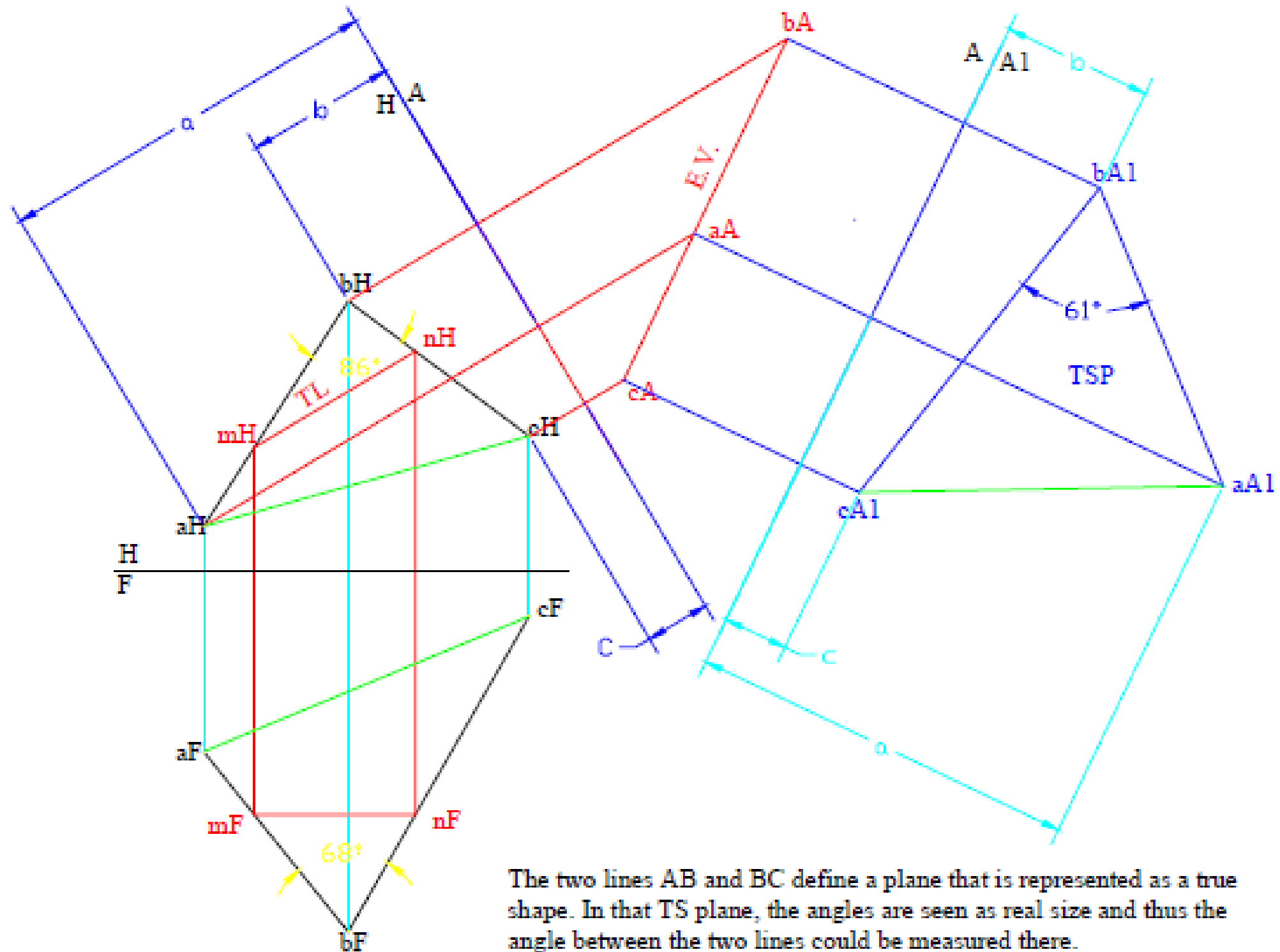

Dihedral angle between planes

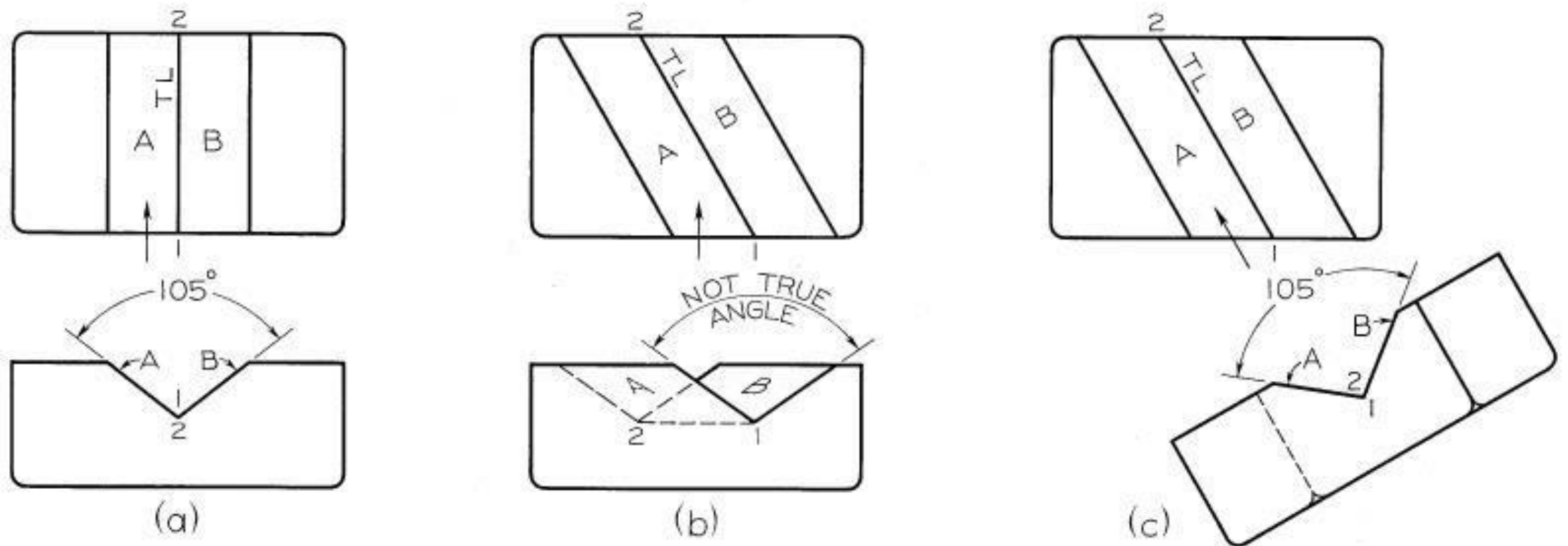

For dihedral angles, the view in which the lines are seen as points must be obtained. The TL line is seen as points overlapped on each other.

Dihedral angle between planes

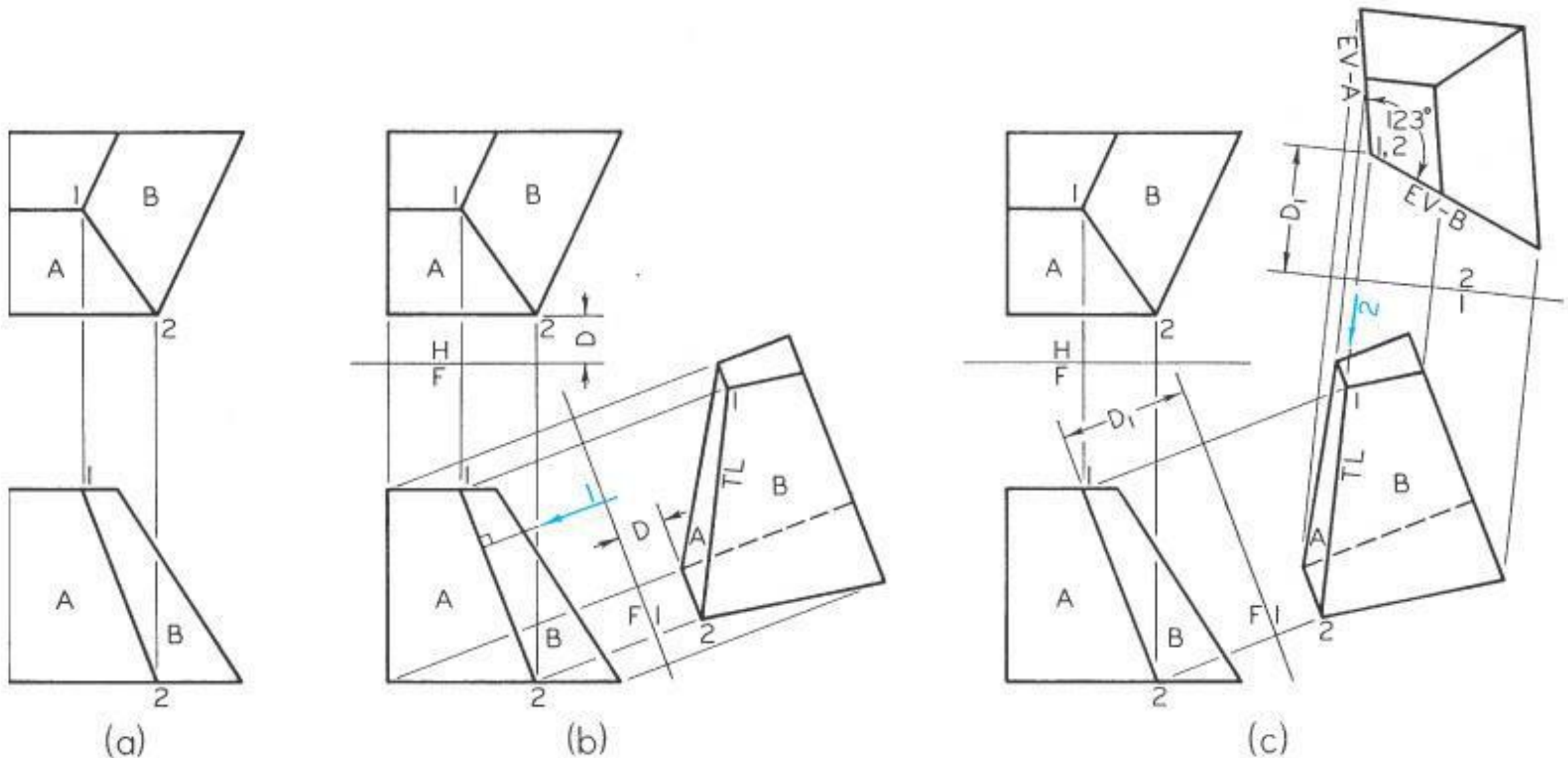

Since line 1-2 is common to both planes A and B, if the line is represented as a point, then both planes will be seen as edge views and the angle between the planes can be found.

Location of Line - plane method

Intersecting a given line to a given angle through a given point.

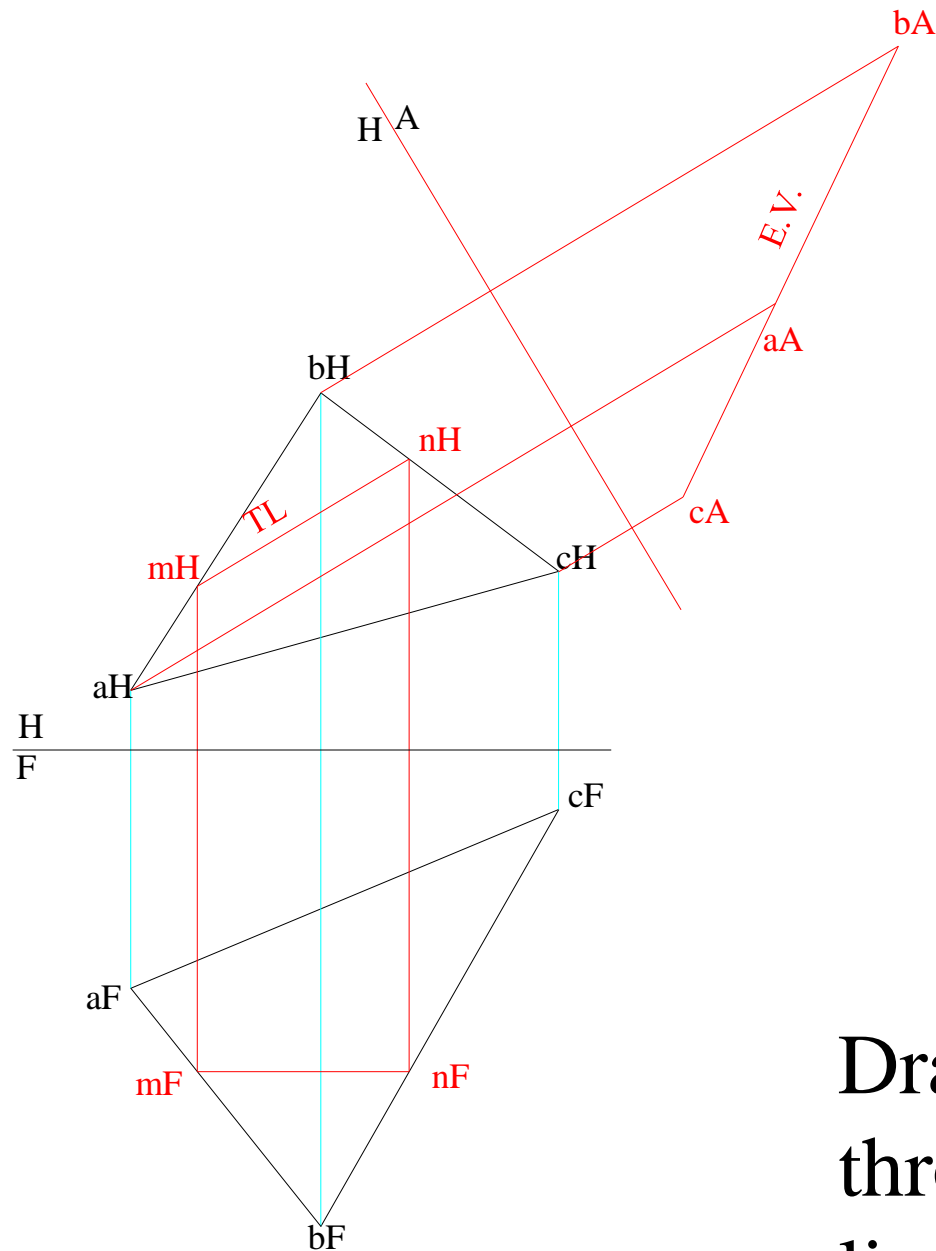

Draw a line (CS) that passes through the point C and intersects line AB at an angle of 75° .

Location of Line - plane method

Intersecting a given line to a given angle through a given point.

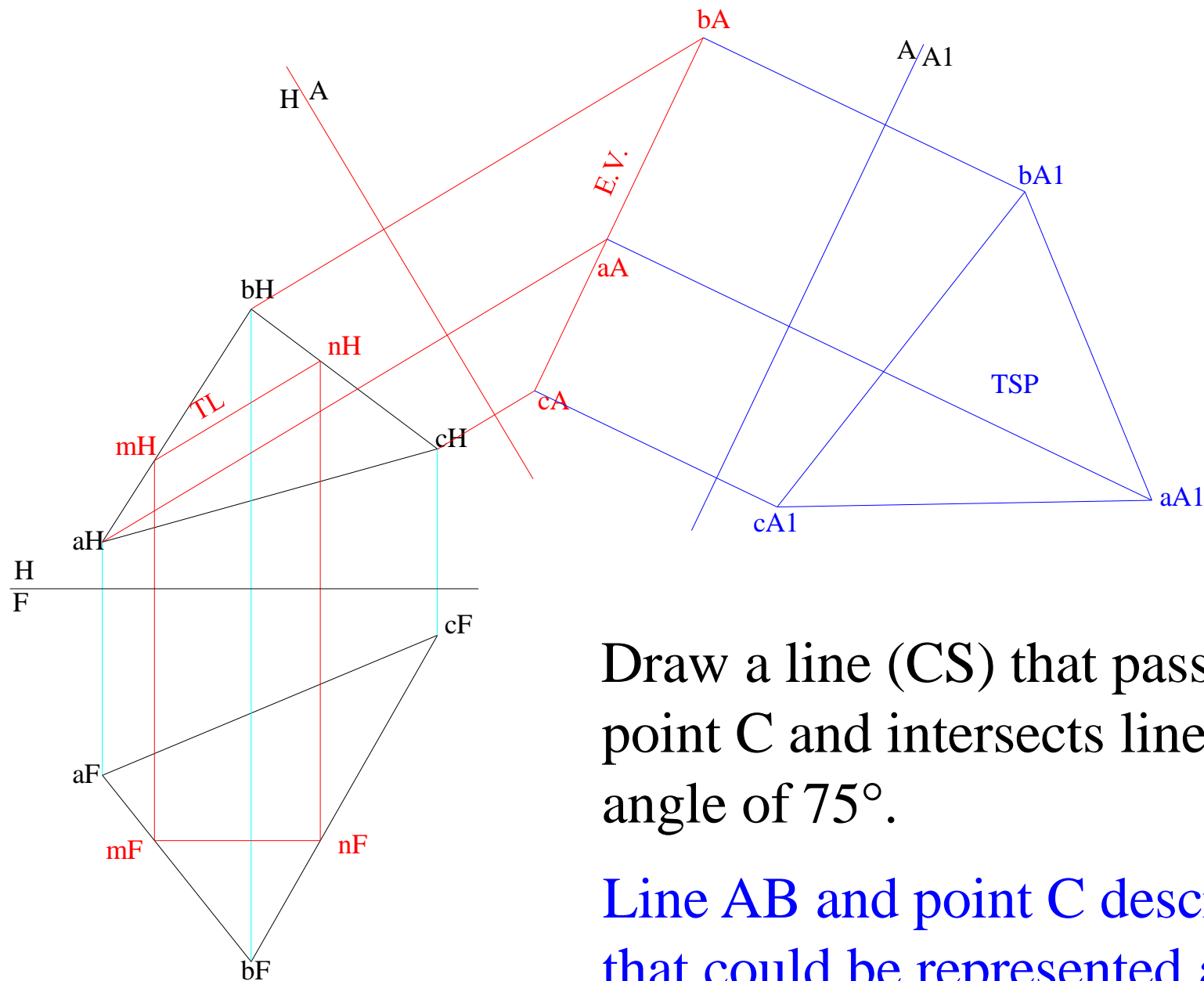

Draw a line (CS) that passes through the point C and intersects line AB at an angle of 75° .

Line AB and point C describe a plane that could be represented as a TS plane (second auxiliary view).

Location of Line - plane method

Intersecting a given line to a given angle through a given point.

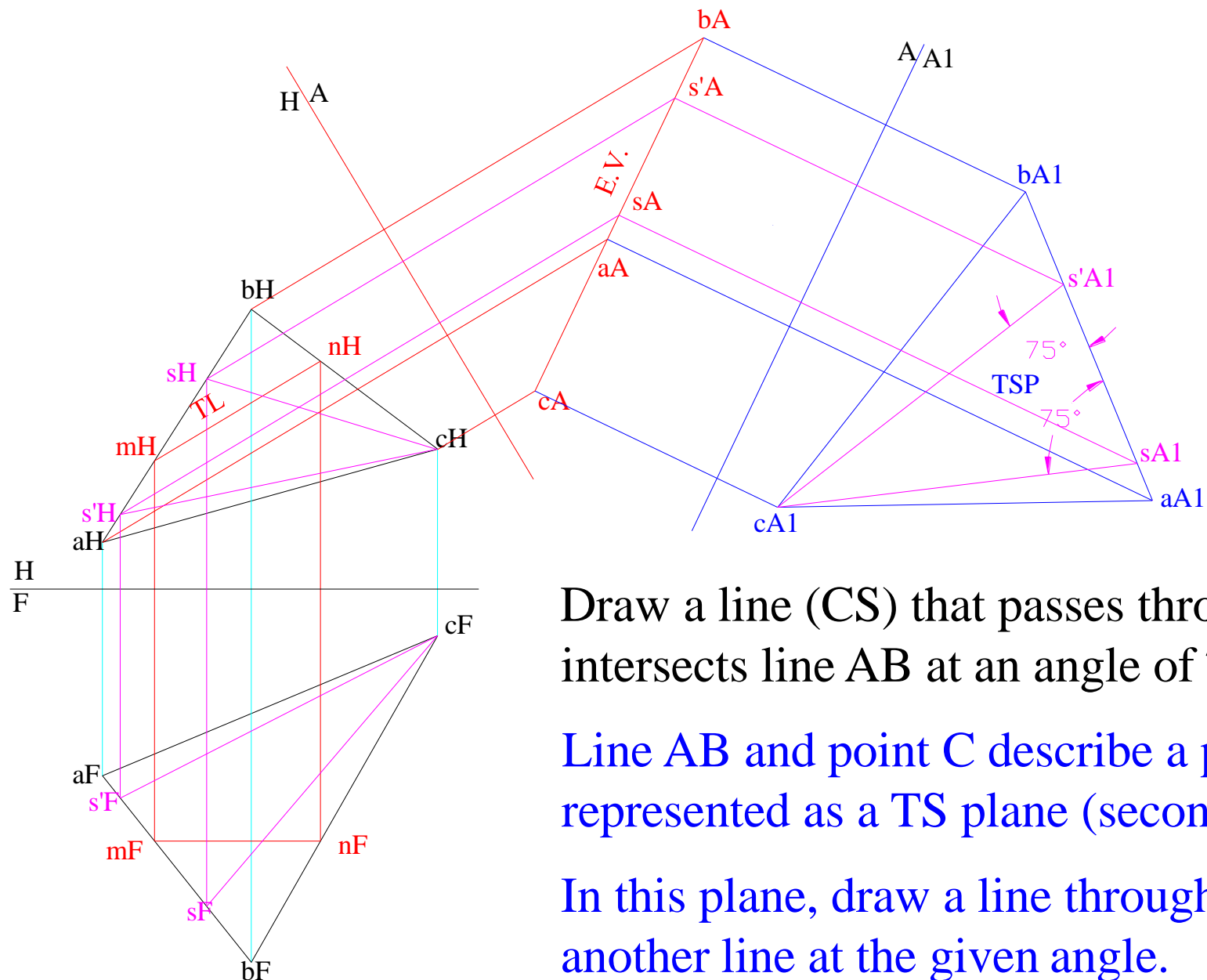

Draw a line (CS) that passes through the point C and intersects line AB at an angle of 75° .

Line AB and point C describe a plane that could be represented as a TS plane (second auxiliary view).

In this plane, draw a line through a point which cuts another line at the given angle.

There are 2 solutions to the problem.

Location of a line through a given point intersecting a given line to a given angle – plane method

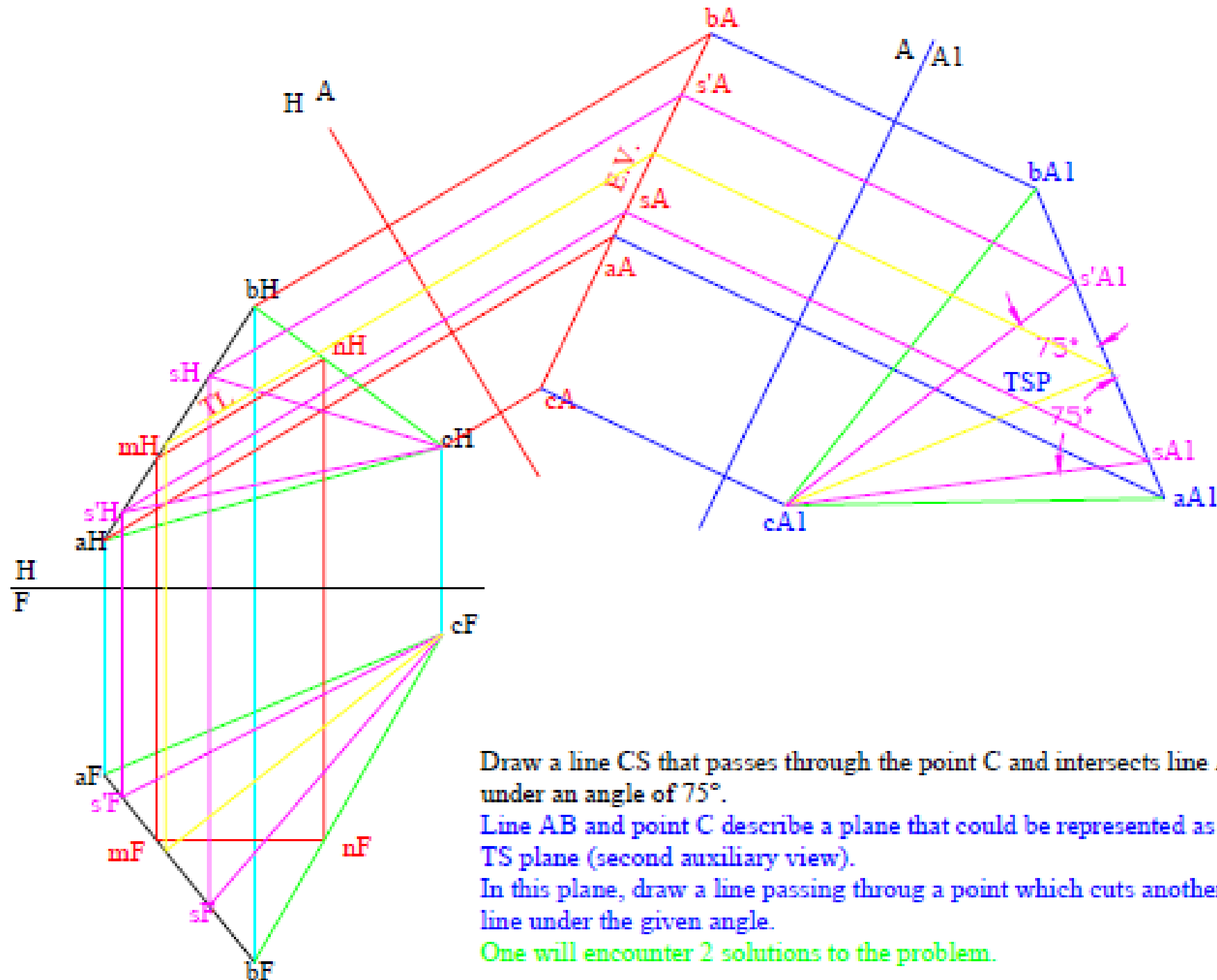

Draw a line CS that passes through the point C and intersects line AB under an angle of 75°.

Line AB and point C describe a plane that could be represented as a TS plane (second auxiliary view).

In this plane, draw a line passing through a point which cuts another line under the given angle.

One will encounter 2 solutions to the problem.

Location of Plane through a point parallel to two lines

Lines AB and EF are skew.
Point C does not belong to
any of the two lines.

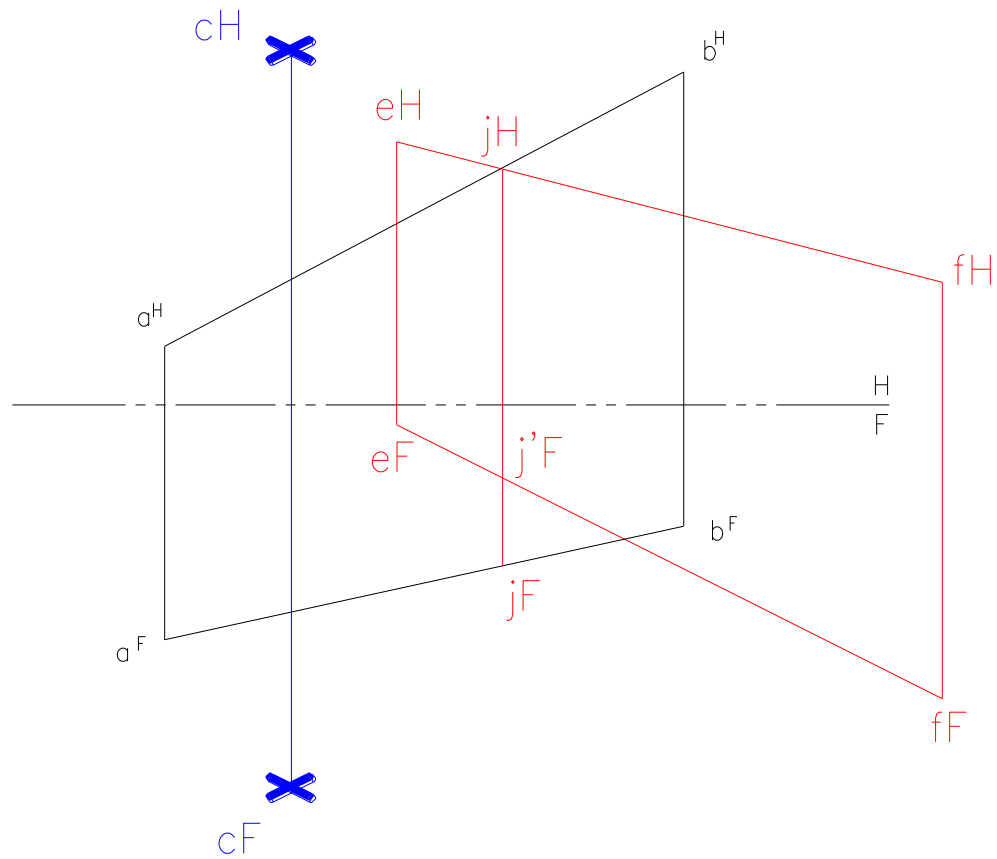

Location of Plane through a point parallel to two lines

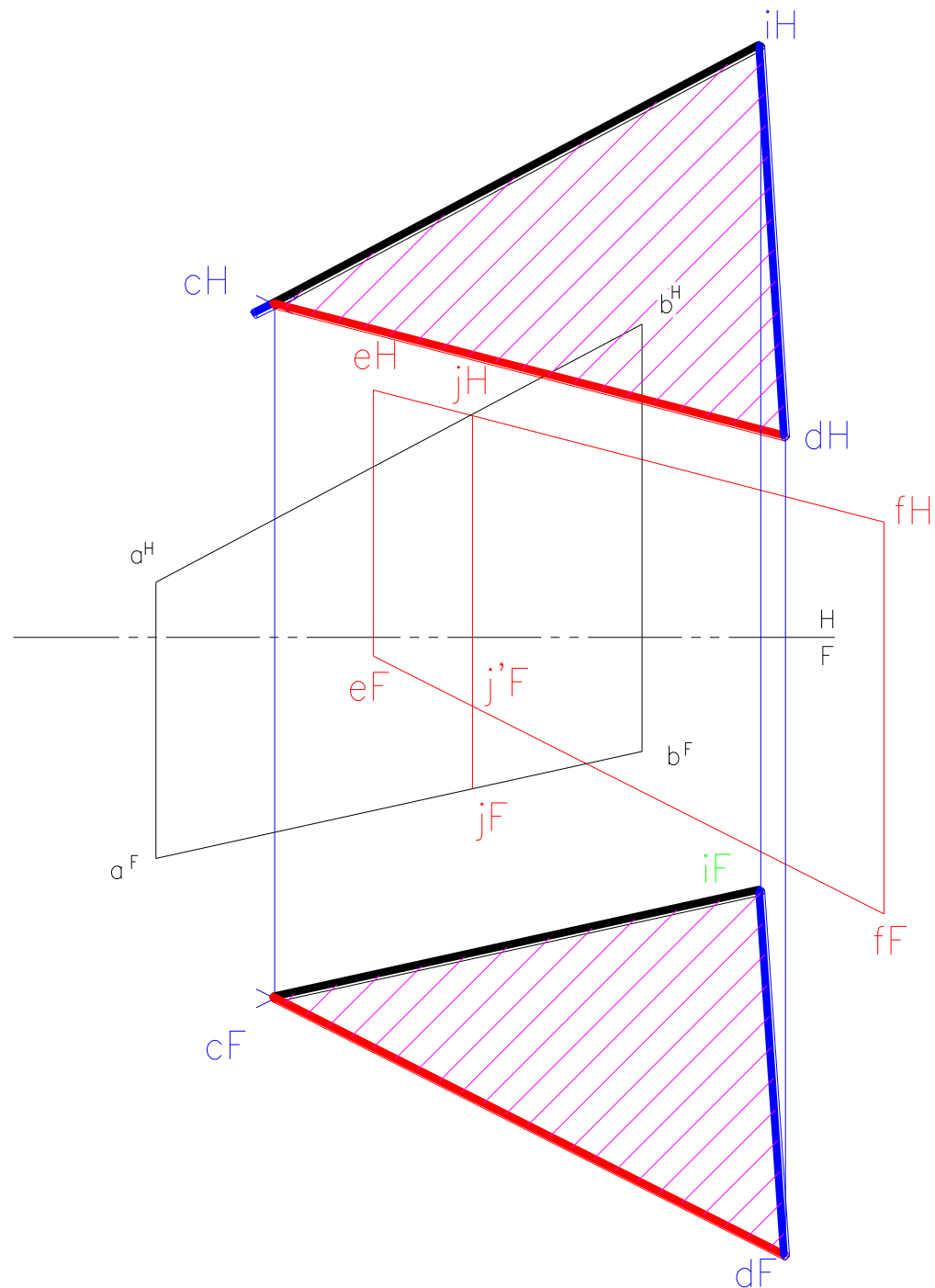

Lines AB and EF are skew. Point C does not belong to any of the two lines.

Draw two lines parallel to given lines AB and EF through point C.

The two intersecting lines will define a plane that contains C and is parallel to the two given lines.

Location of a plane through a point parallel to two lines

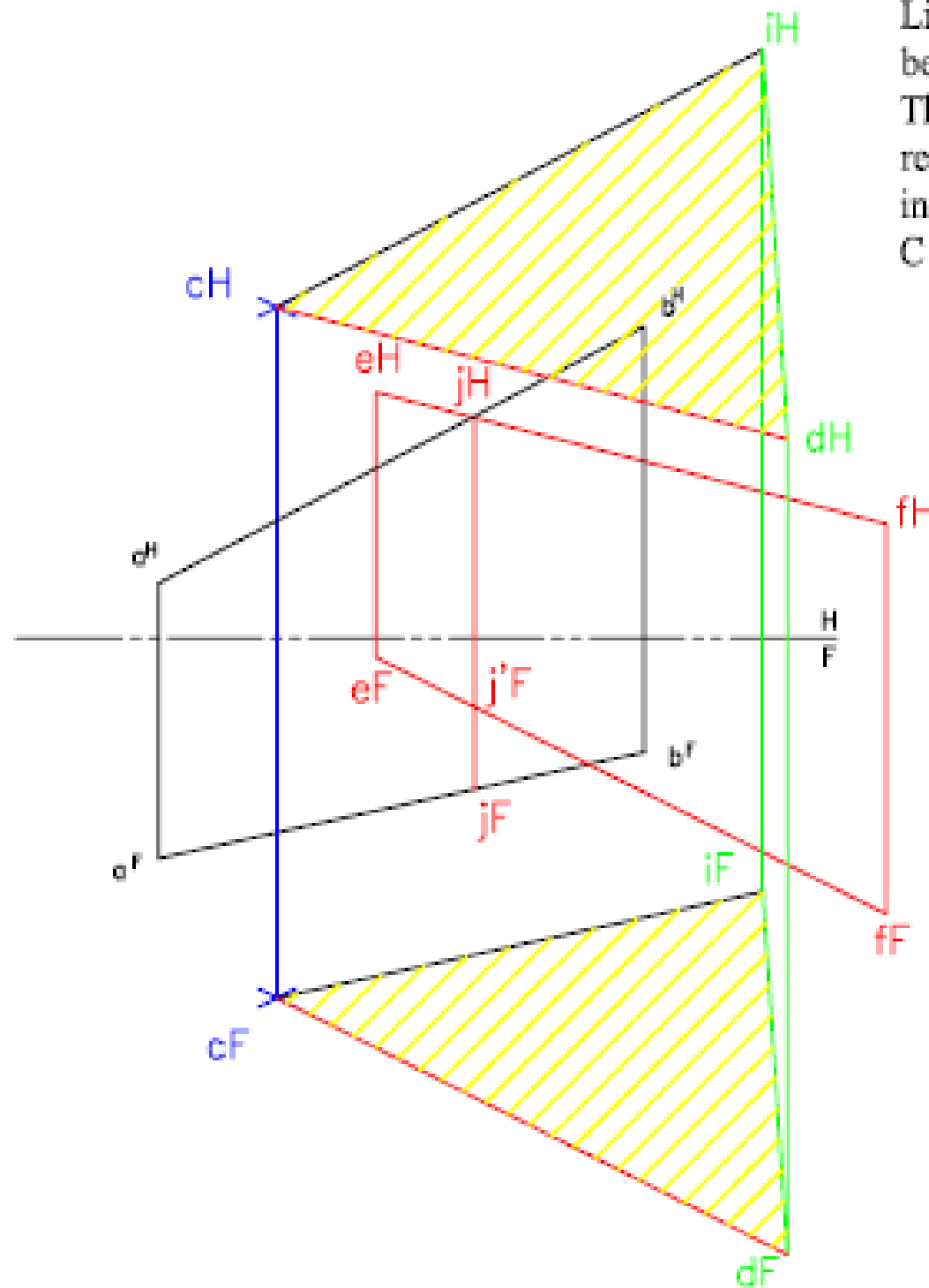

Lines AB and EF are skew. Point C is not belonging of any of the two lines.
Through the point C draw two parallel lines to the respective given lines AB and EF. The two intersecting lines will define a plane that contains C and is parallel to the two given lines.

Shortest line – point method

between two given skew lines

Ⓐ SHORTEST DISTANCE BETWEEN TWO SKEW LINES.

Determine the shortest distance between lines AB and CD

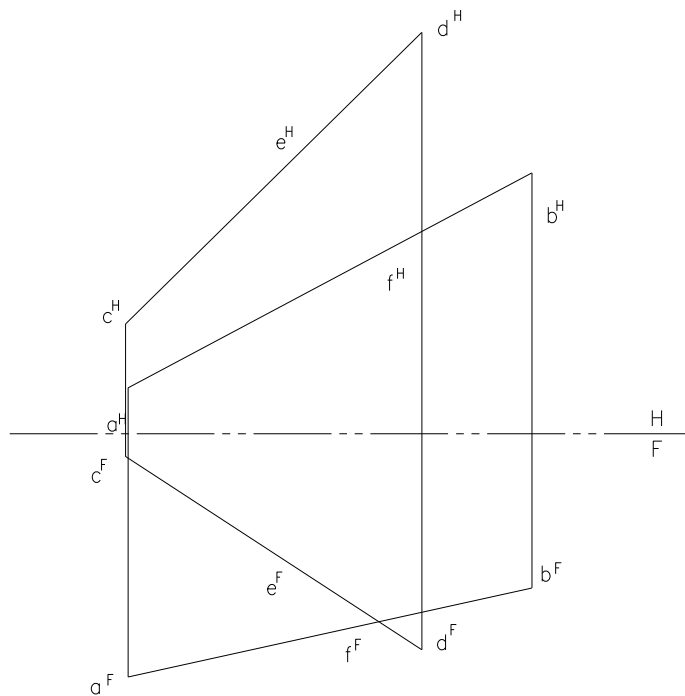

Shortest line – point method

between two given skew lines.

(A) SHORTEST DISTANCE BETWEEN TWO SKEW LINES.

Determine the shortest distance between lines AB and CD

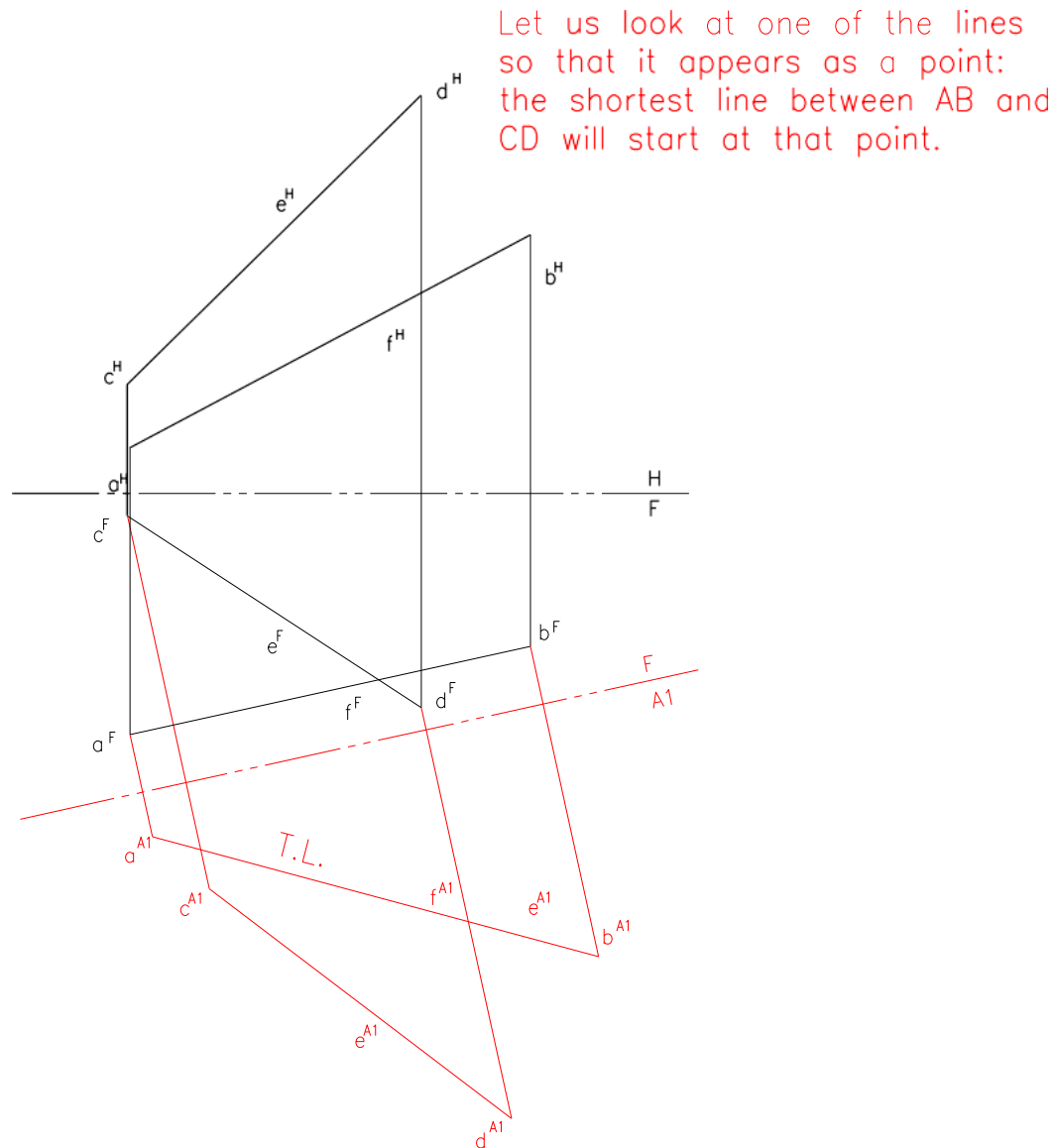

Shortest line – point method between two given skew lines.

(A) SHORTEST DISTANCE BETWEEN TWO SKEW LINES.

Determine the shortest distance between lines AB and CD

Let us look at one of the lines so that it appears as a point: the shortest line between AB and CD will start at that point.

The shortest distance is a line perpendicular to both AB and CD,

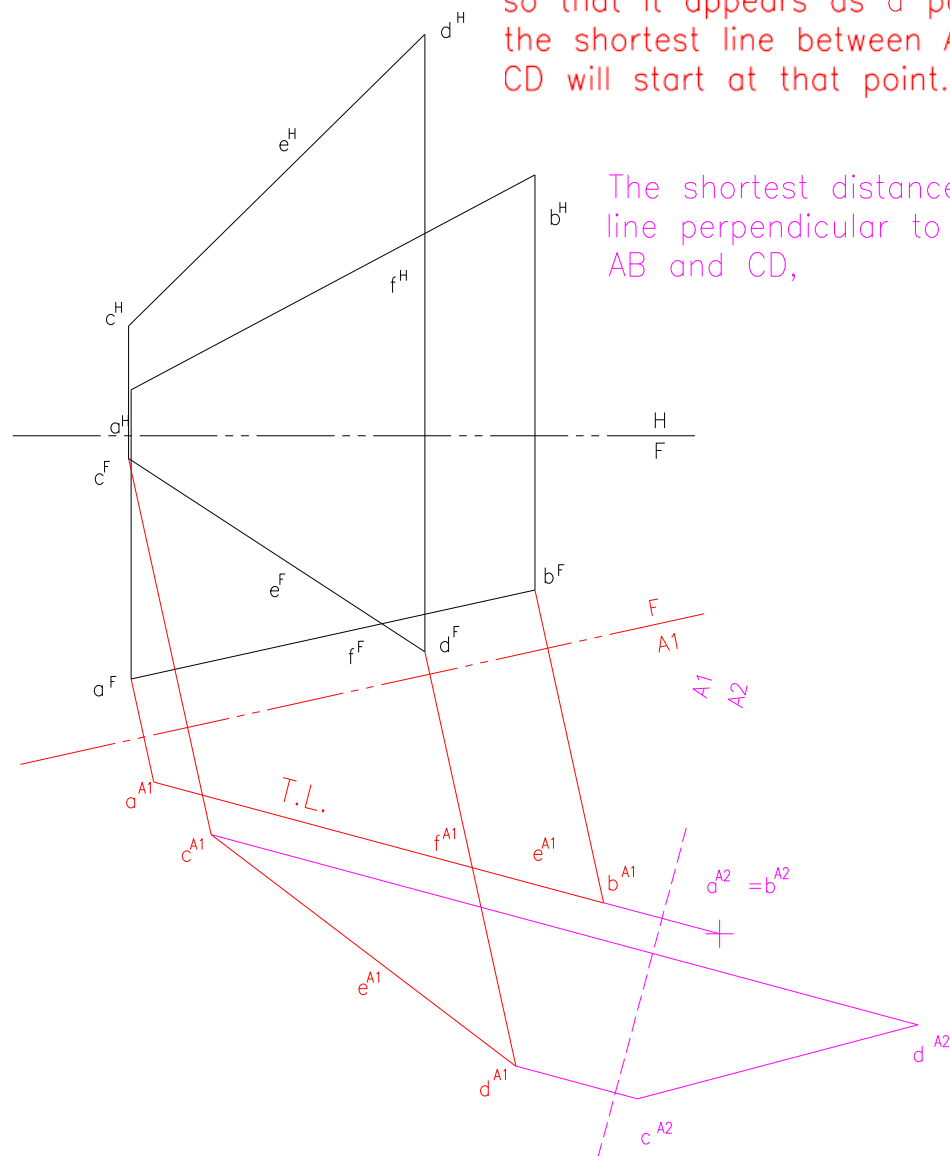

Shortest line – point method

between two given skew lines

(A) SHORTEST DISTANCE BETWEEN TWO SKEW LINES.

Determine the shortest distance between lines AB and CD

Let us look at one of the lines so that it appears as a point: the shortest line between AB and CD will start at that point.

The shortest distance is a line perpendicular to both AB and CD,

Therefore we build a perpendicular to CD.

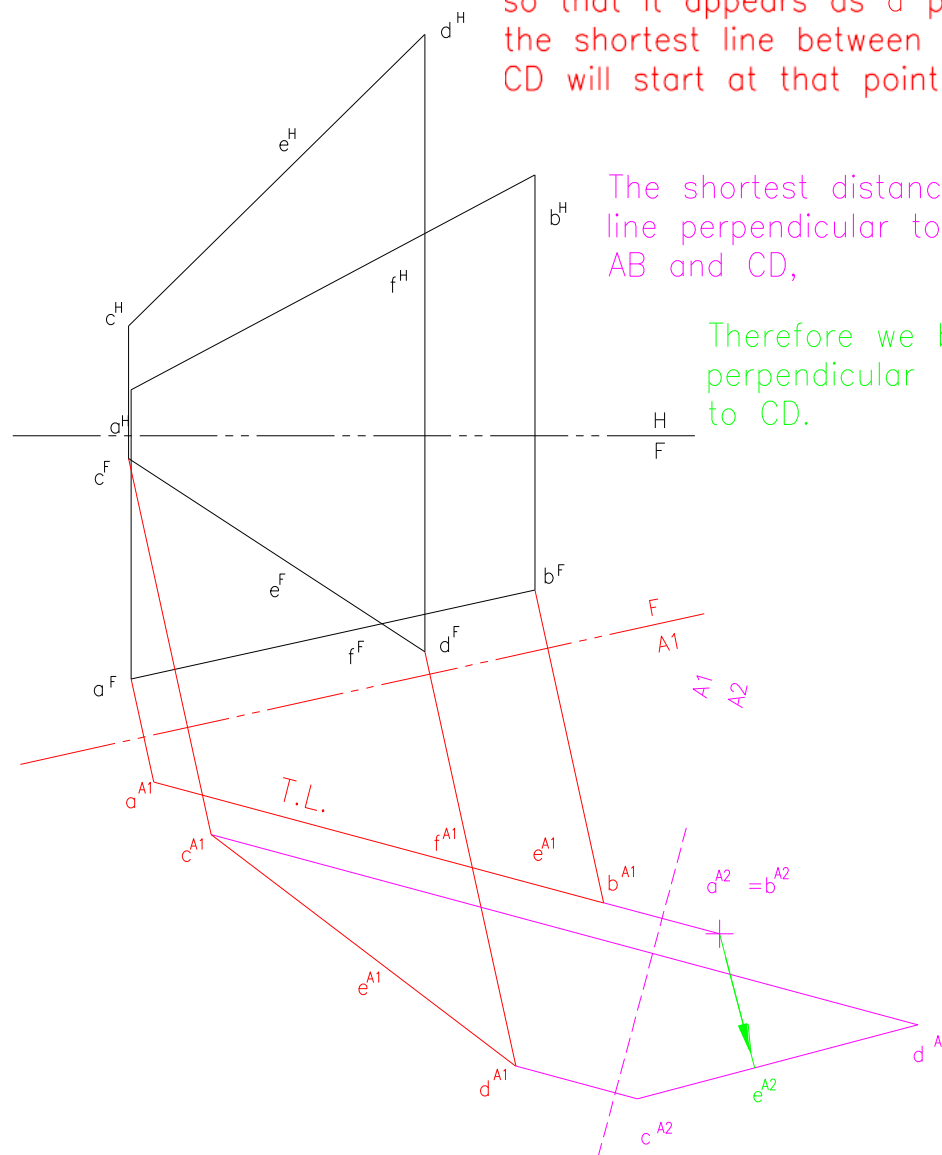

Shortest line – point method between two given skew lines.

(A) SHORTEST DISTANCE BETWEEN TWO SKEW LINES.

Determine the shortest distance between lines AB and CD

Let us look at one of the lines so that it appears as a point: the shortest line between AB and CD will start at that point.

The shortest distance is a line perpendicular to both AB and CD,

Therefore we build a perpendicular to CD.

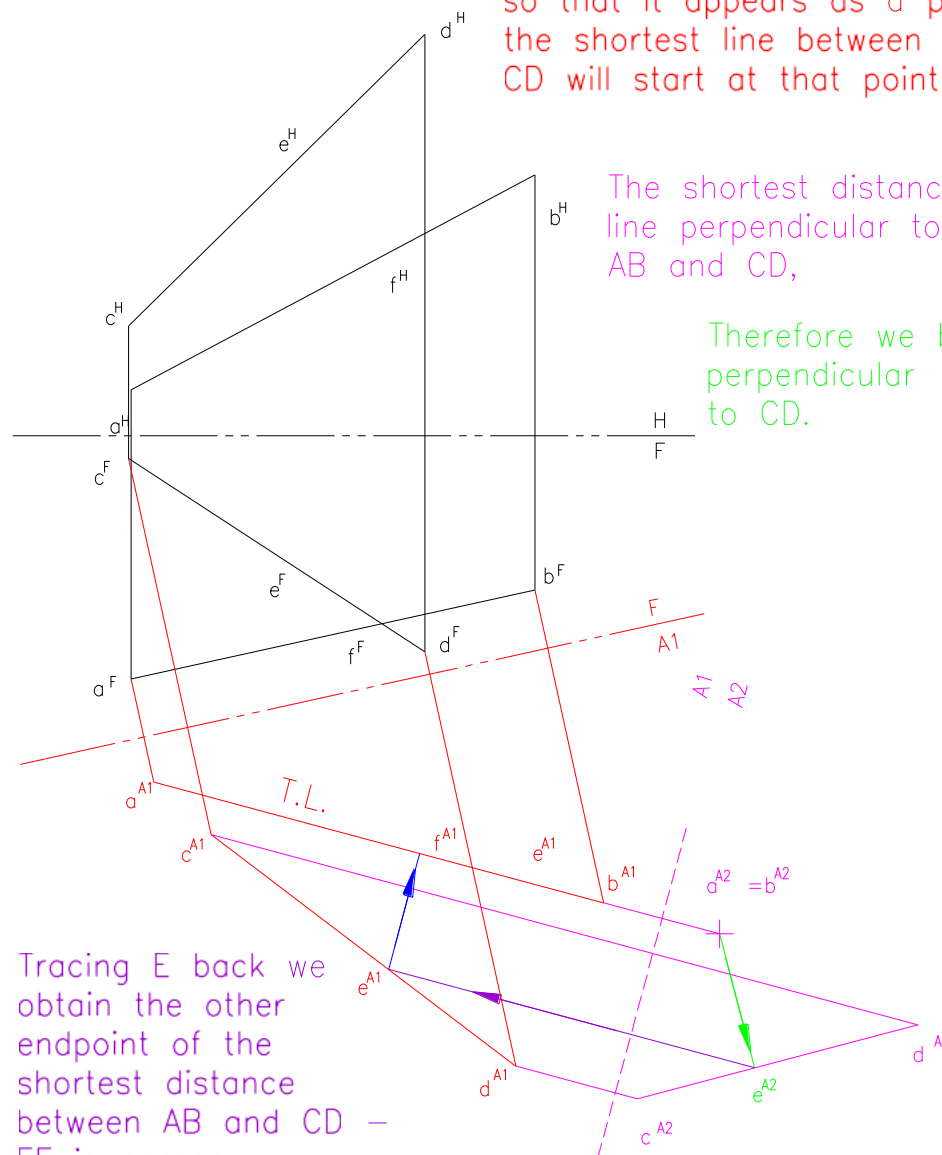

Tracing E back we obtain the other endpoint of the shortest distance between AB and CD – EF is perpendicular to AB.

Shortest line – point method

between two given skew lines

(A) SHORTEST DISTANCE BETWEEN TWO SKEW LINES.

Determine the shortest distance between lines AB and CD

Let us look at one of the lines so that it appears as a point: the shortest line between AB and CD will start at that point.

The shortest distance is a line perpendicular to both AB and CD,

Therefore we build a perpendicular to CD.

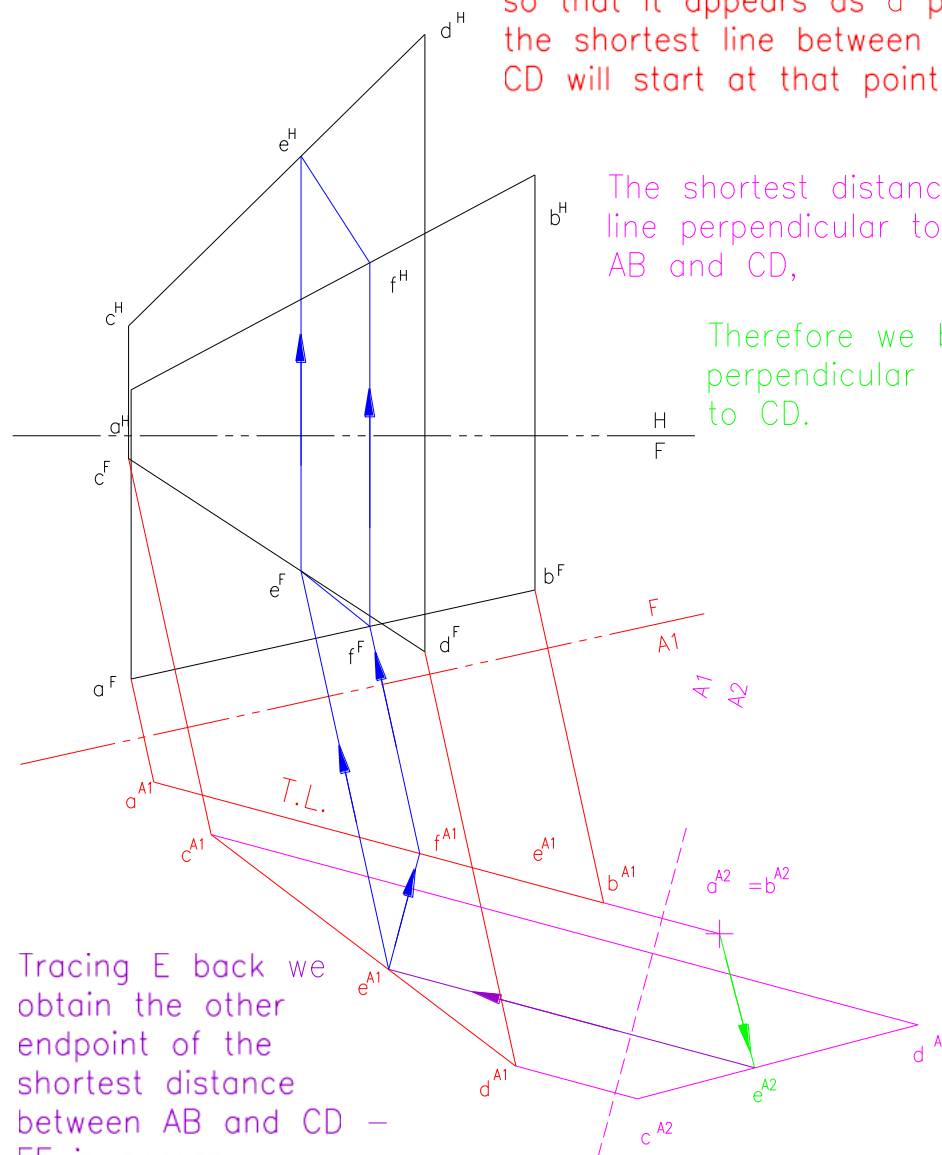

Tracing E back we obtain the other endpoint of the shortest distance between AB and CD – EF is perpendicular to AB.

Shortest Line – Plane Method between two given skew lines

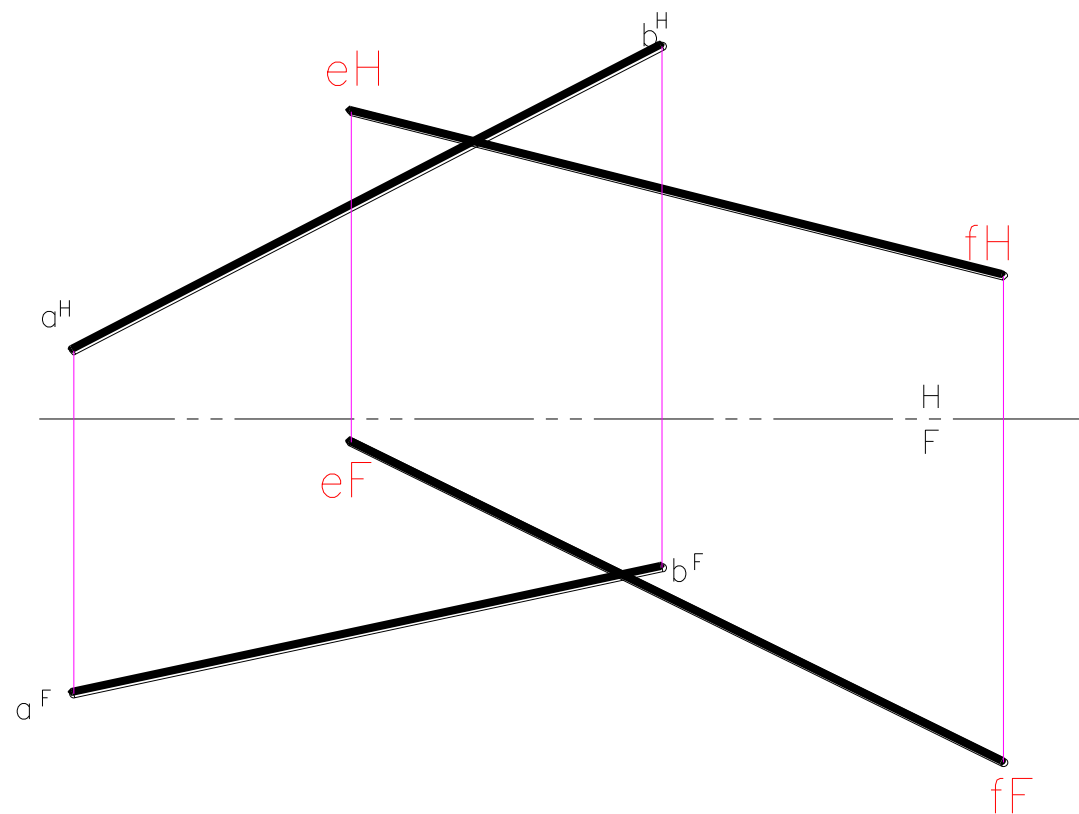

Shortest Line – Plane Method between two given skew lines

Plane EFG is completed in such a way that line FG is parallel to skew line AB. The edge view of this plane is parallel to AB.

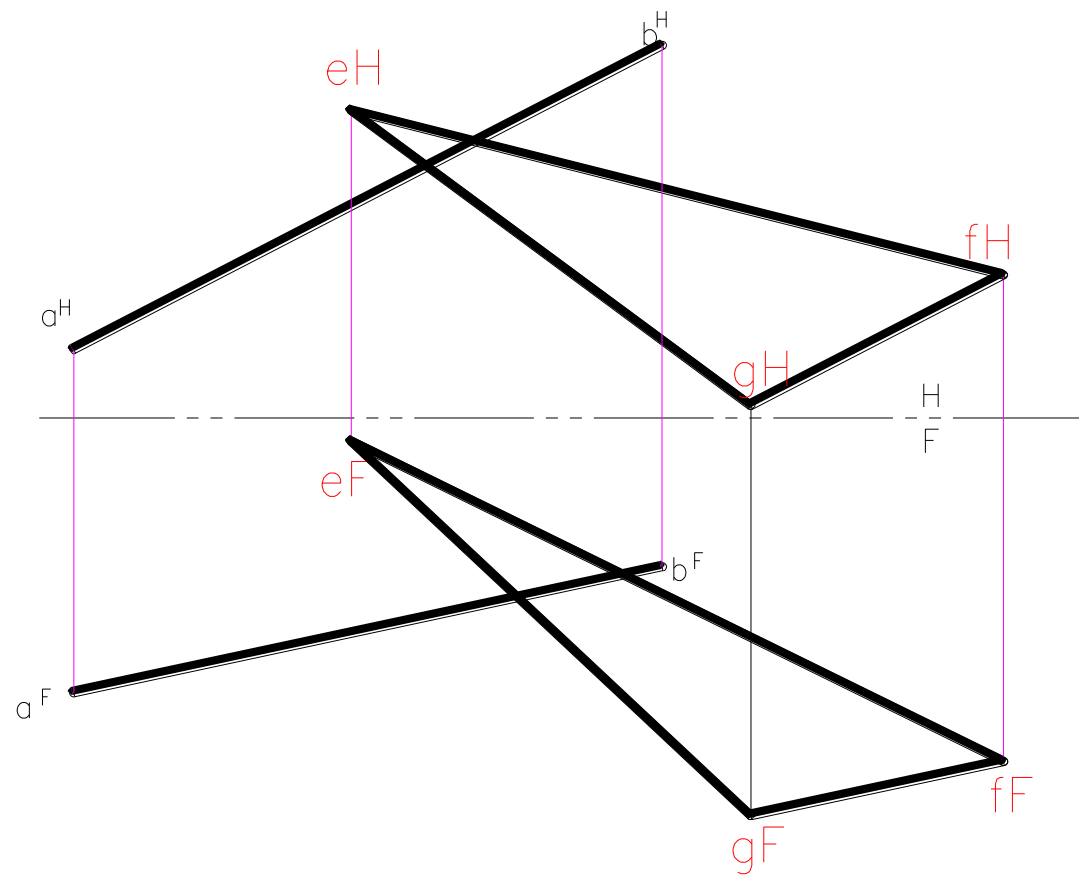

Shortest Line – Plane Method between two given skew lines

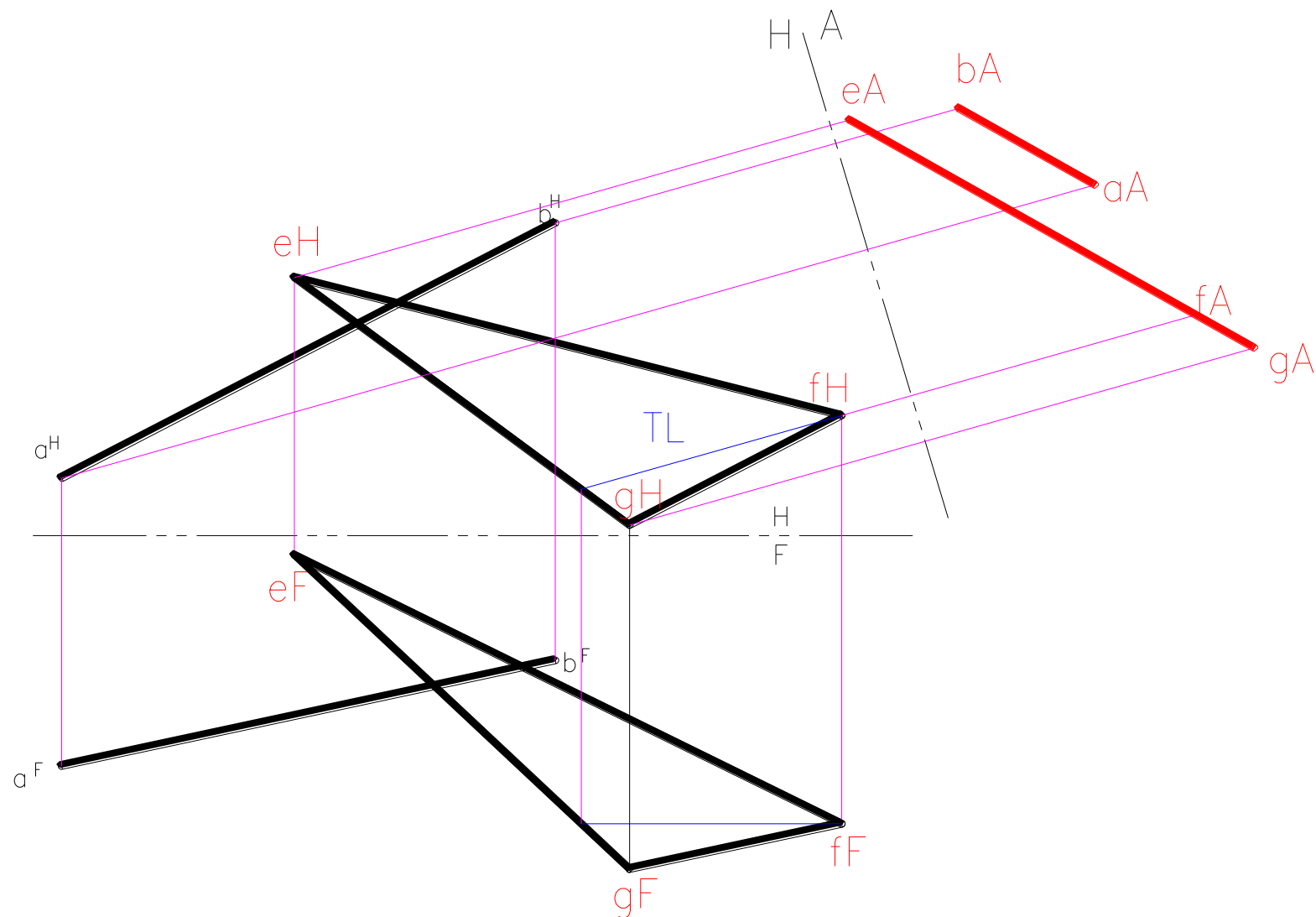

Shortest Line – Plane Method between two given skew lines

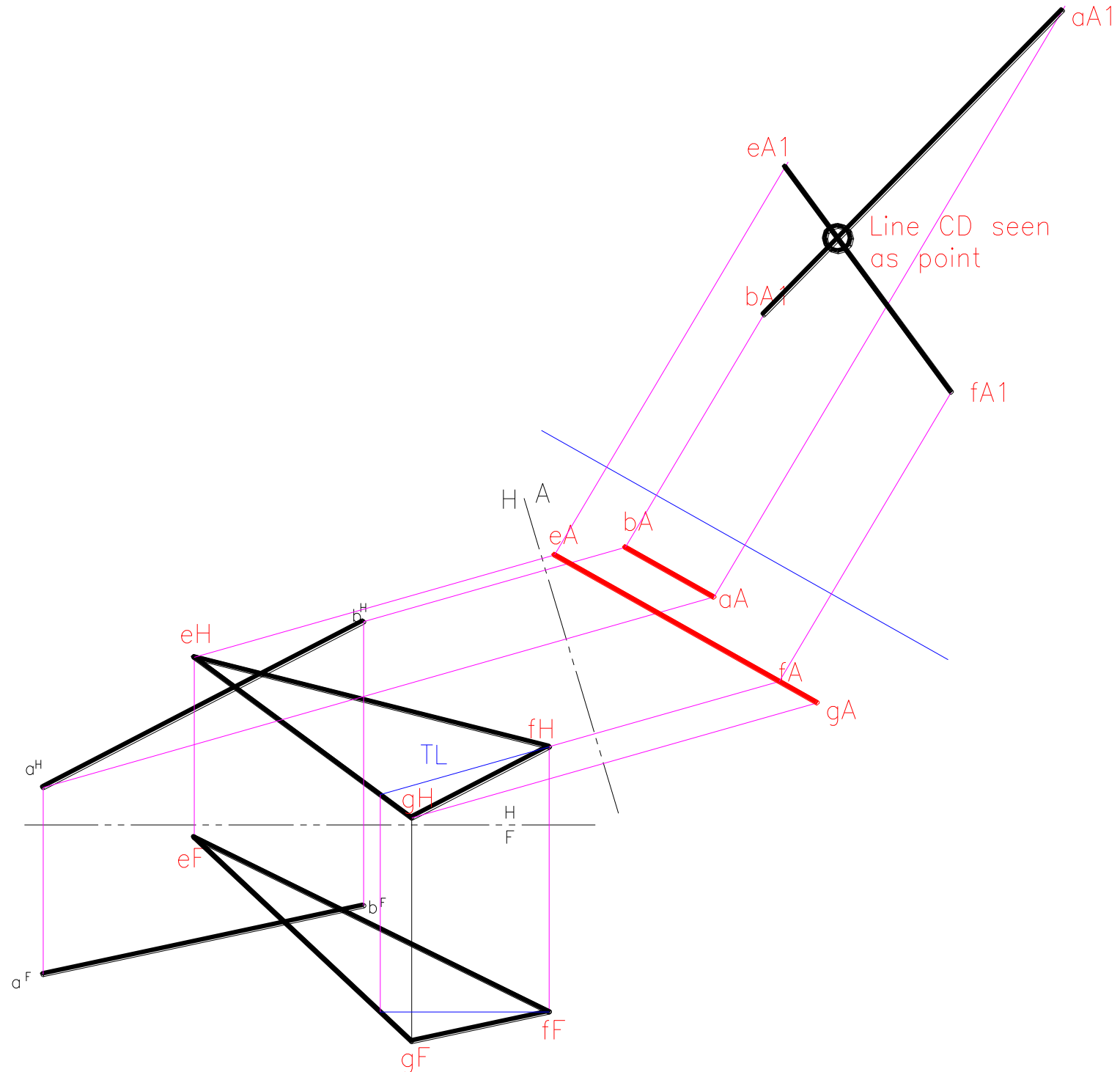

Shortest Line – Plane Method between two given skew lines

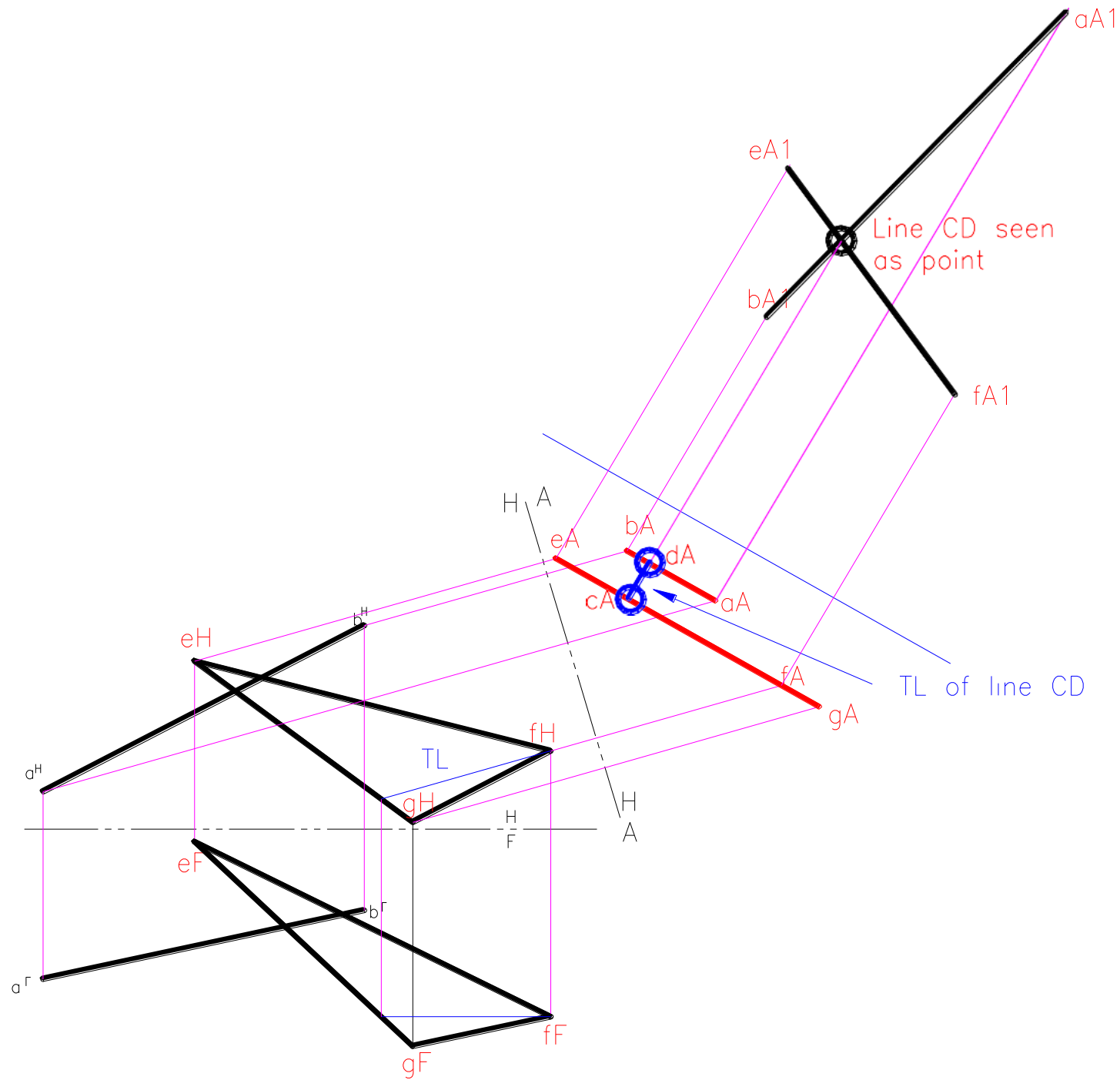

Shortest Line – Plane Method between two given skew lines

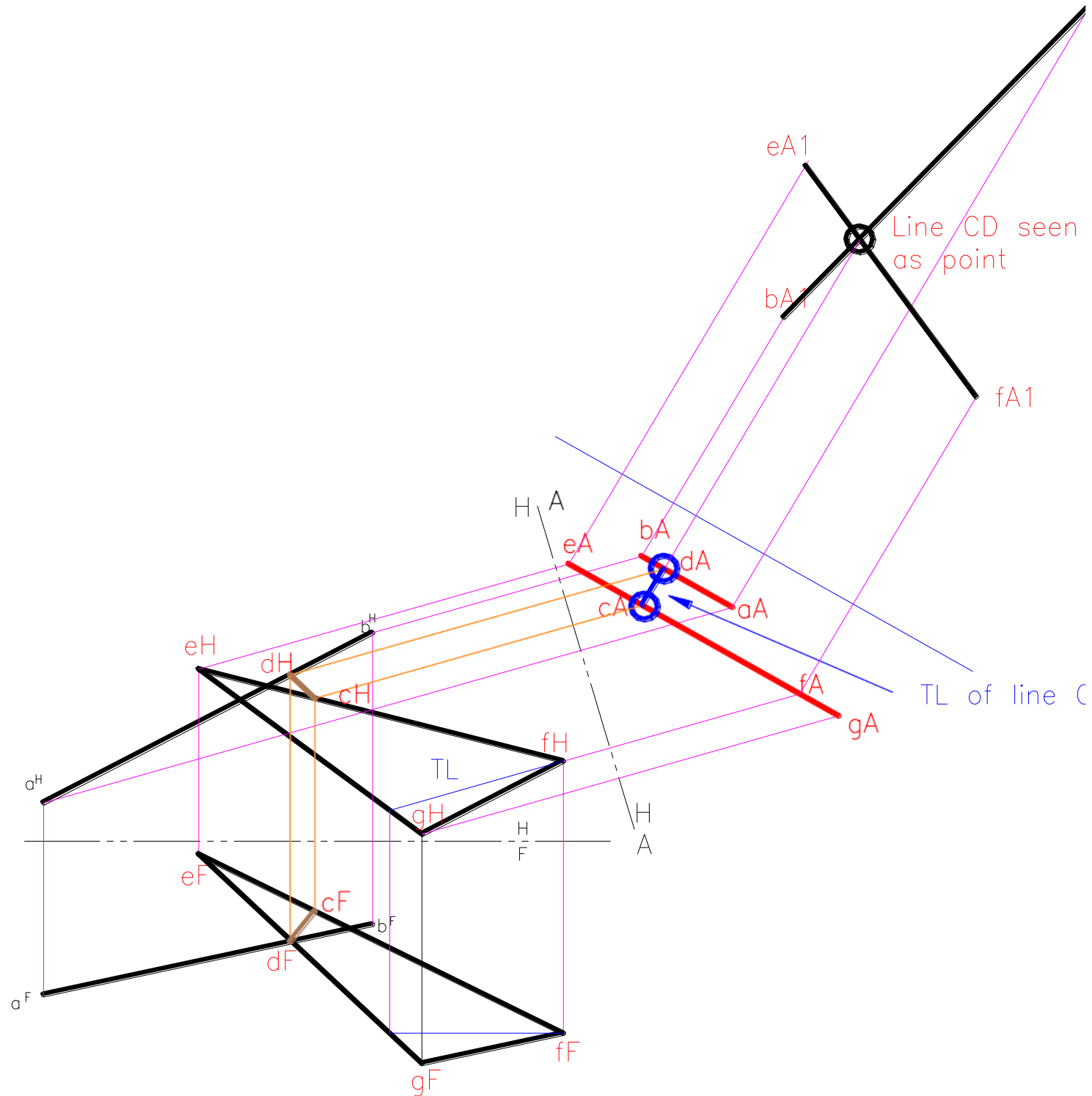

Shortest Horizontal Line between two given skew lines - Plane Method

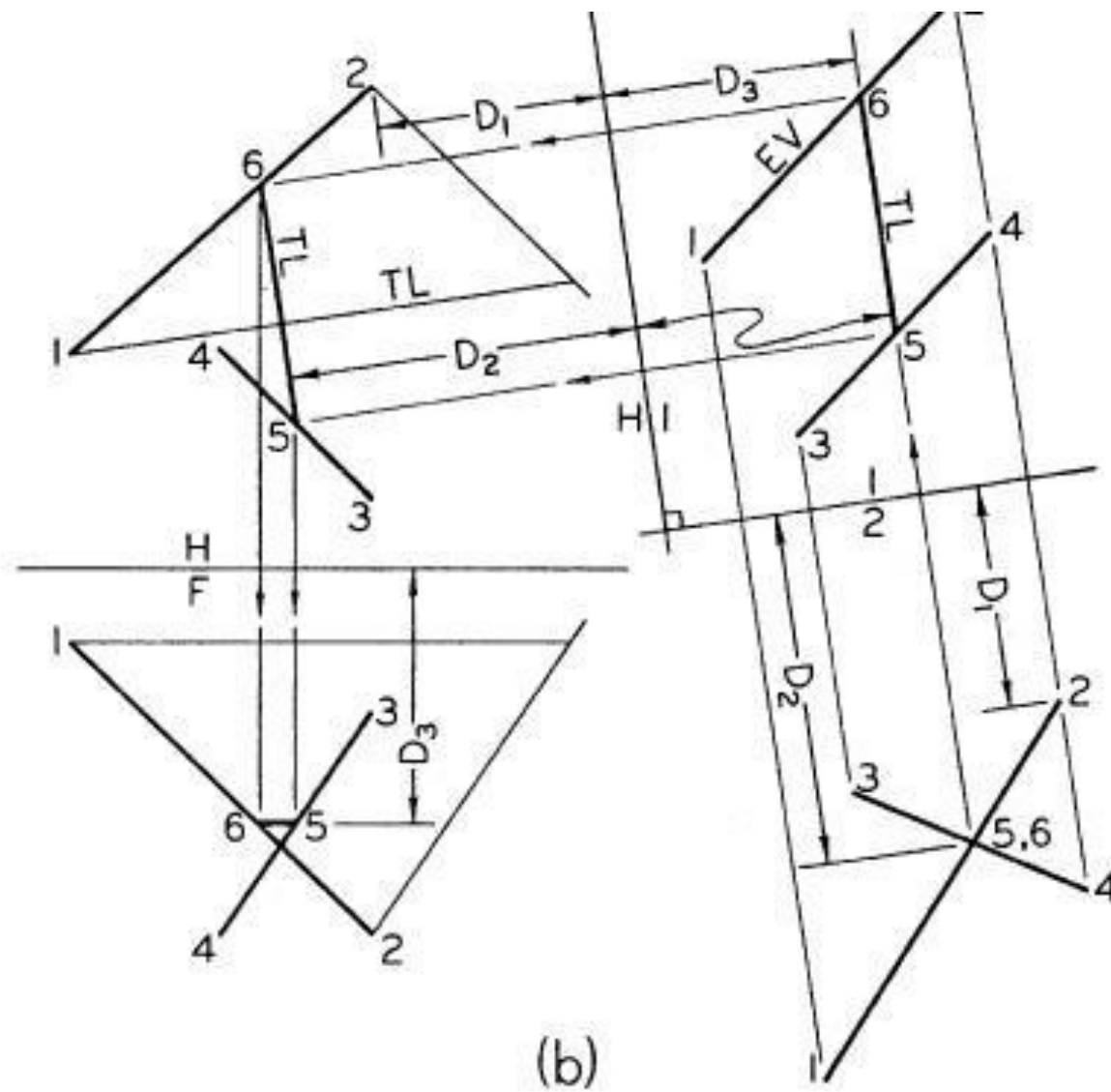
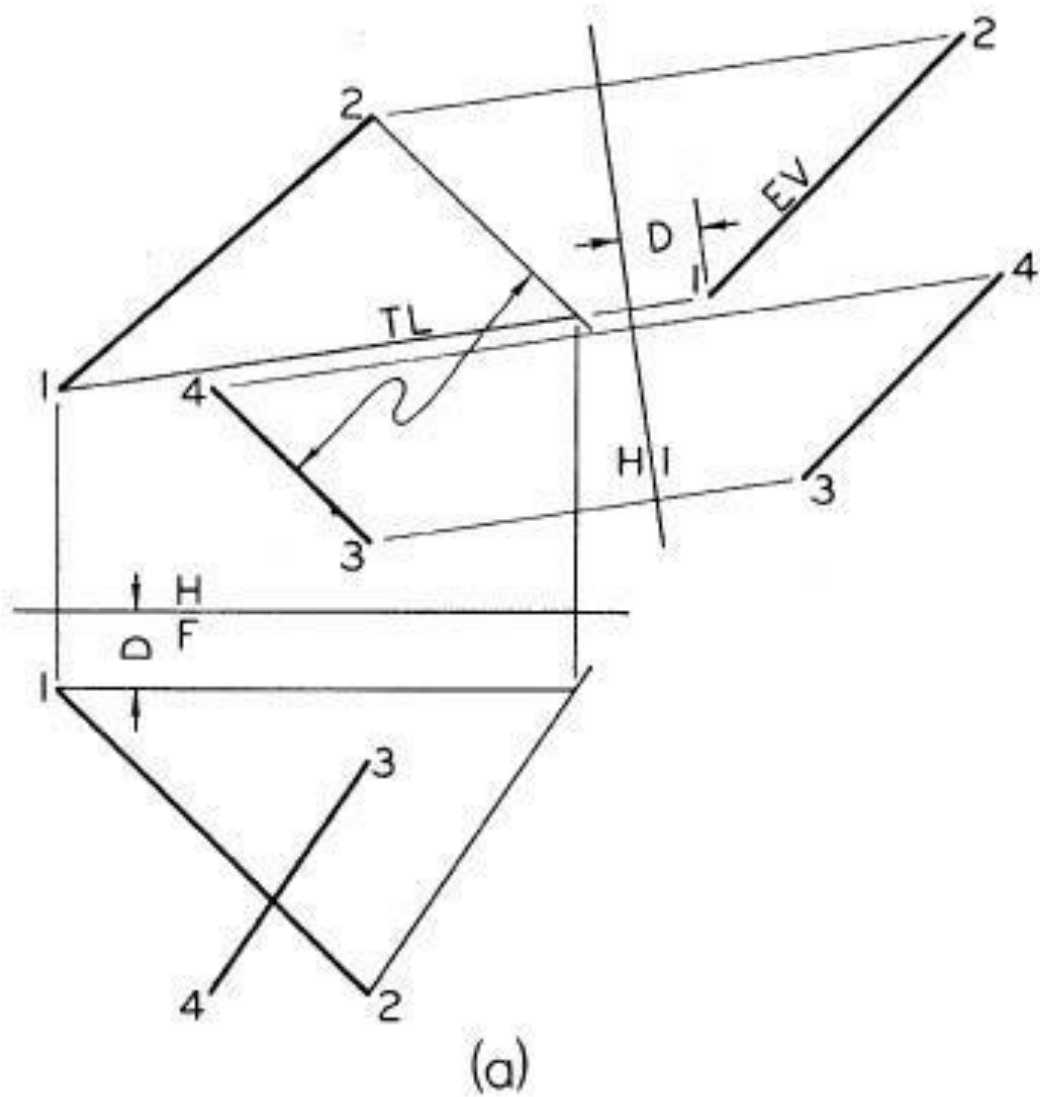

Shortest Horizontal Line between two given skew lines - Plane Method

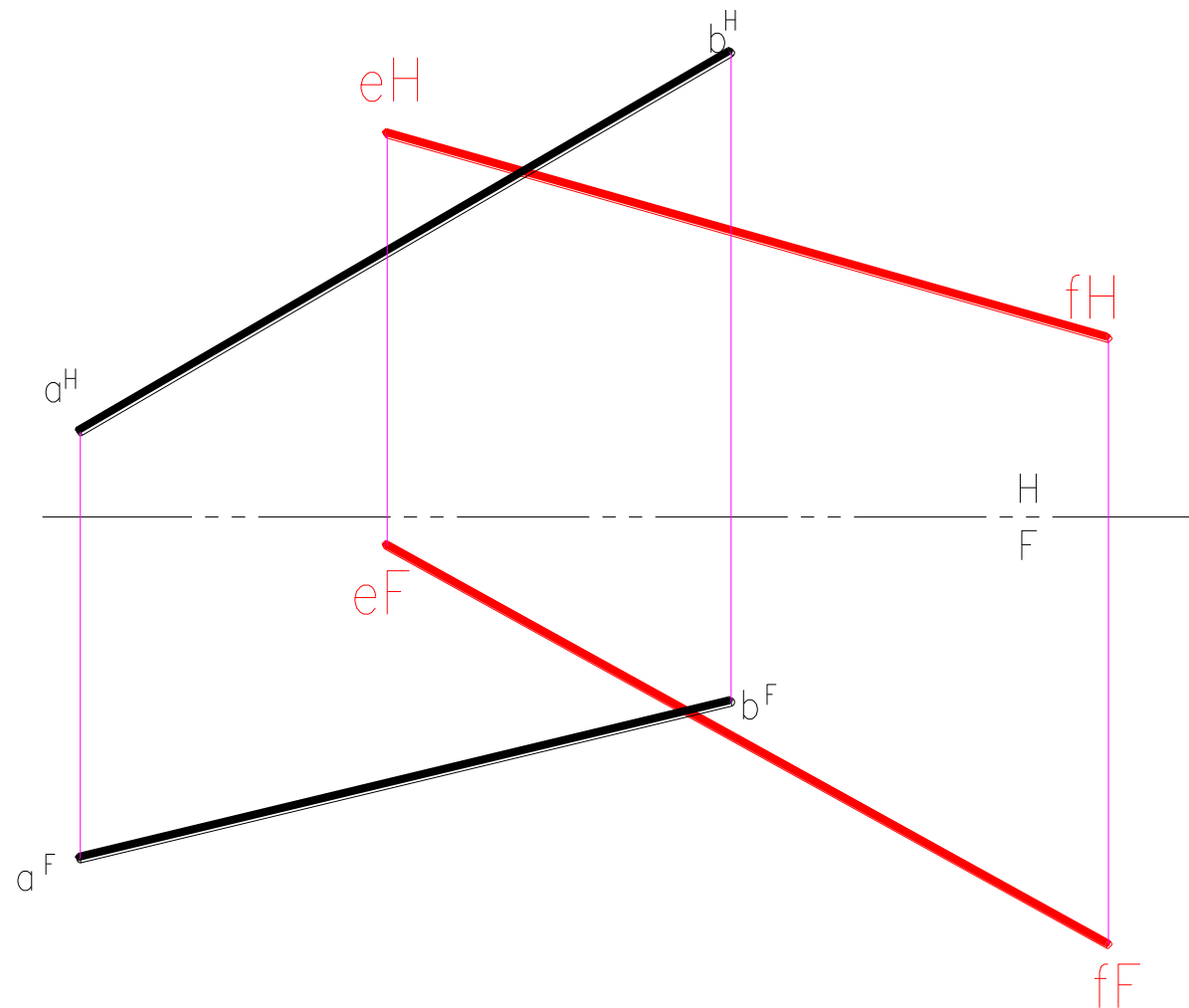

Shortest Horizontal Line between two given skew lines - Plane Method

Plane EFG is completed in such a way that line FG is parallel to skew line AB. The edge view of this plane is parallel to AB.

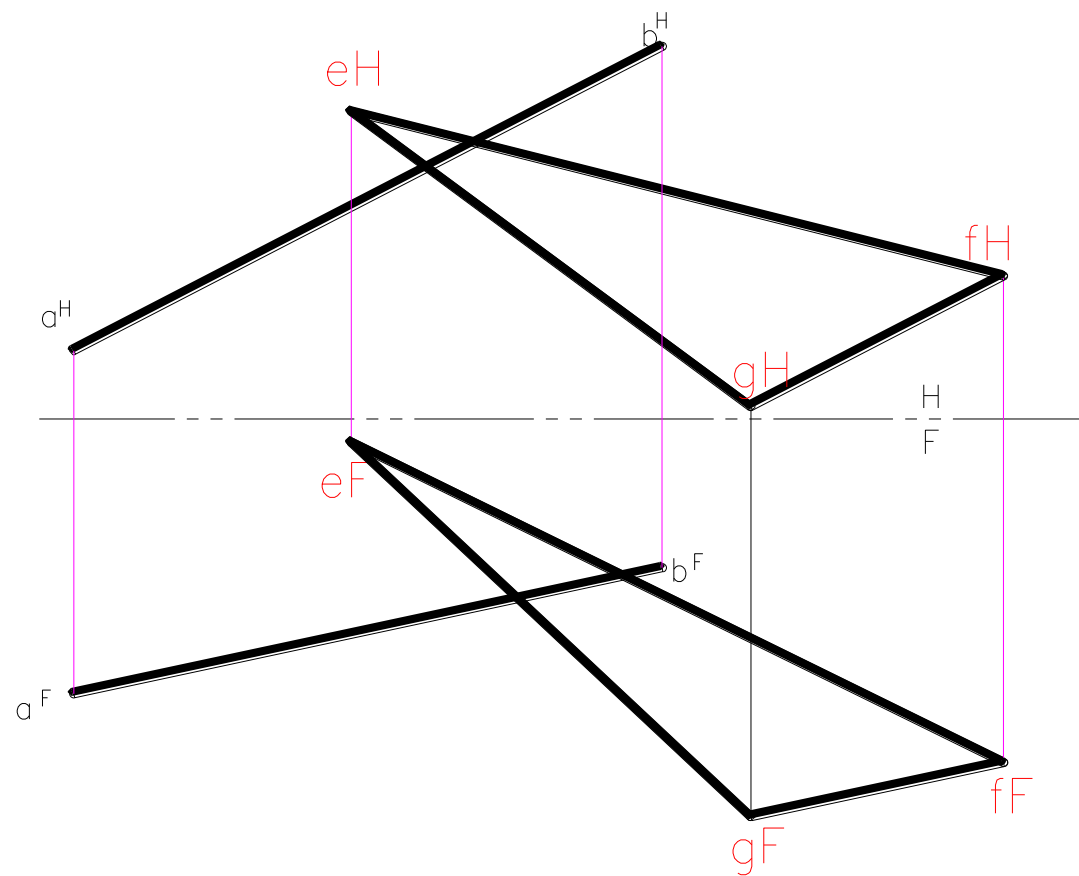

Shortest Horizontal Line between two given skew lines - Plane Method

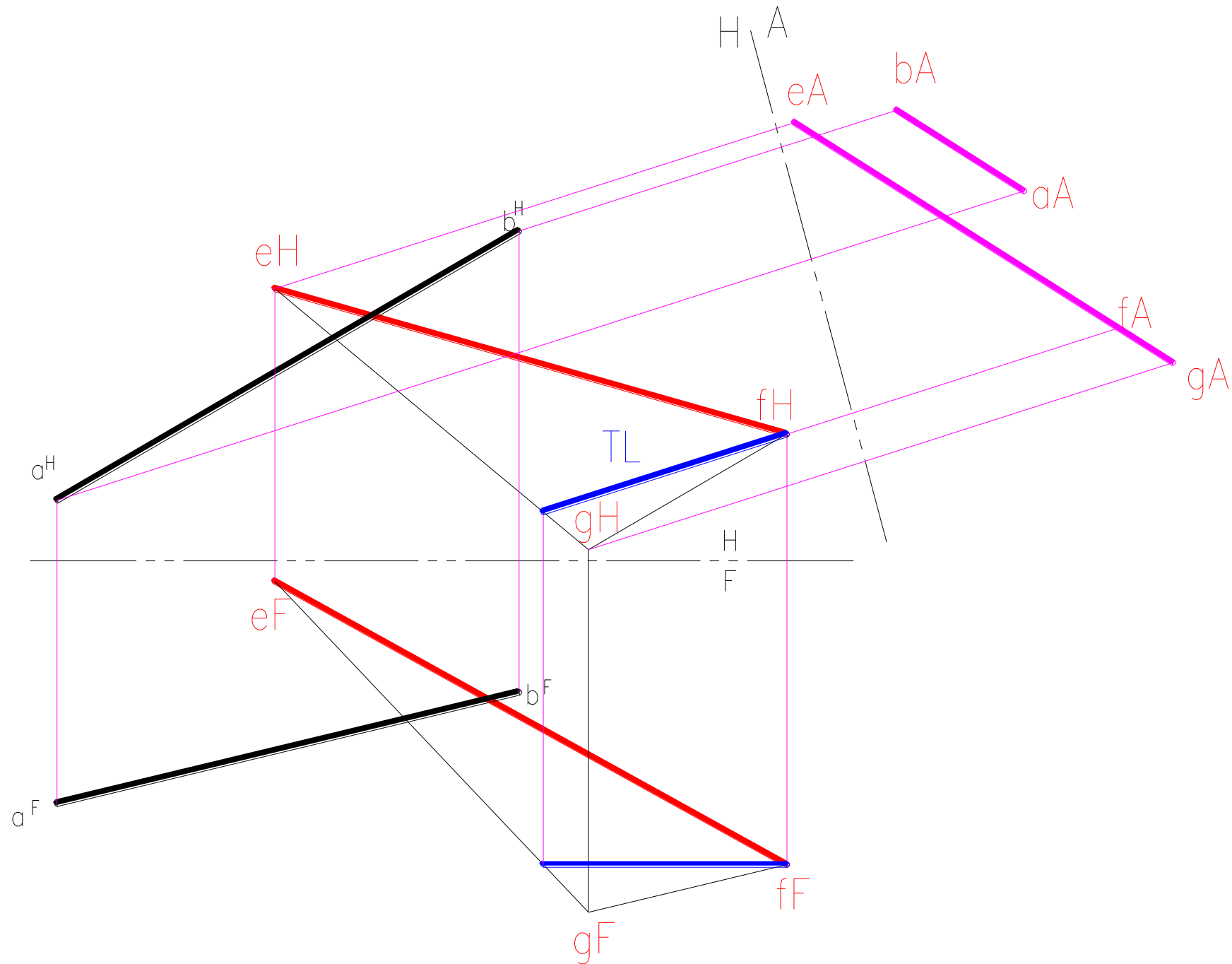

Shortest Horizontal Line between two given skew lines - Plane Method

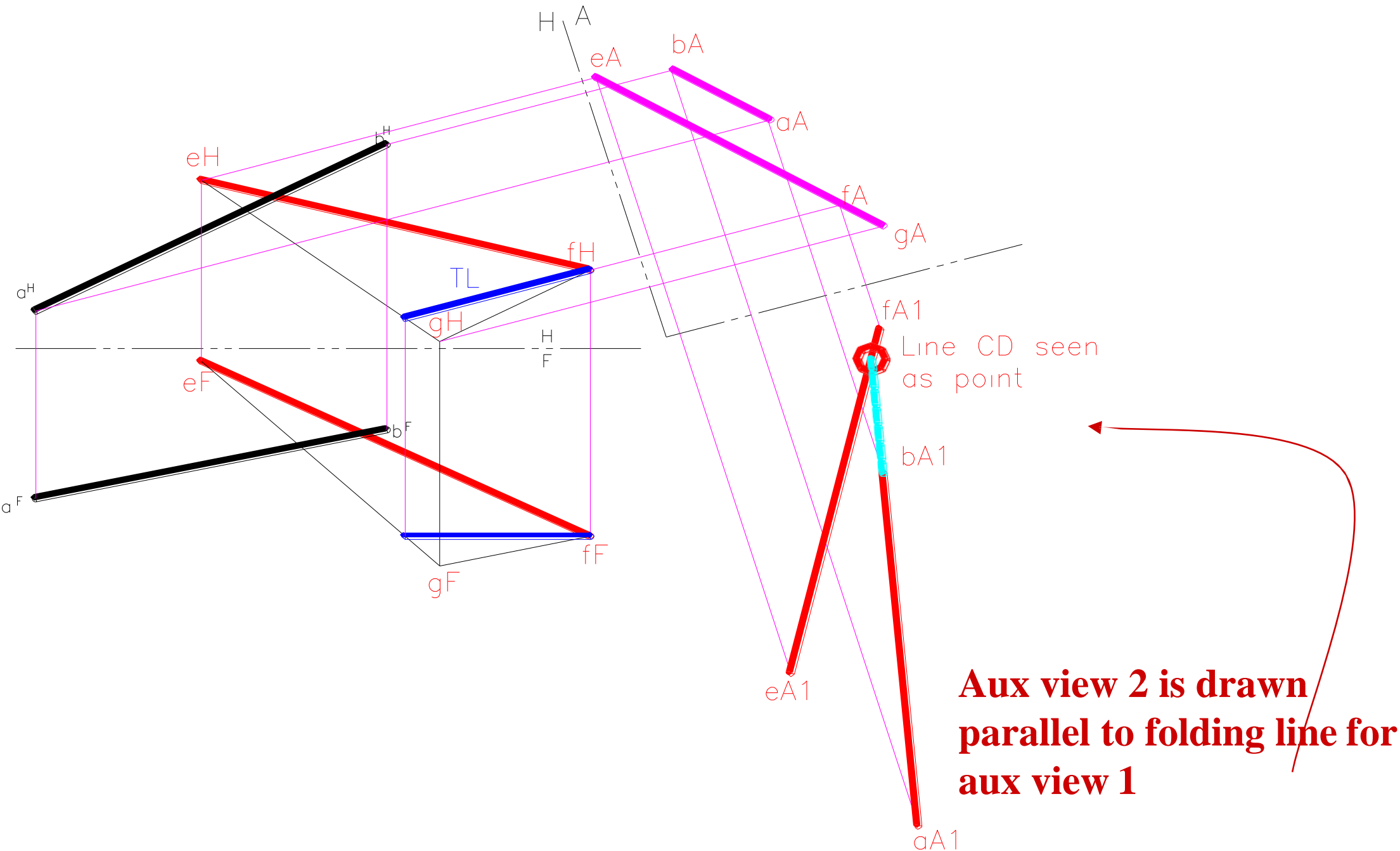

Shortest Horizontal Line between two given skew lines - Plane Method

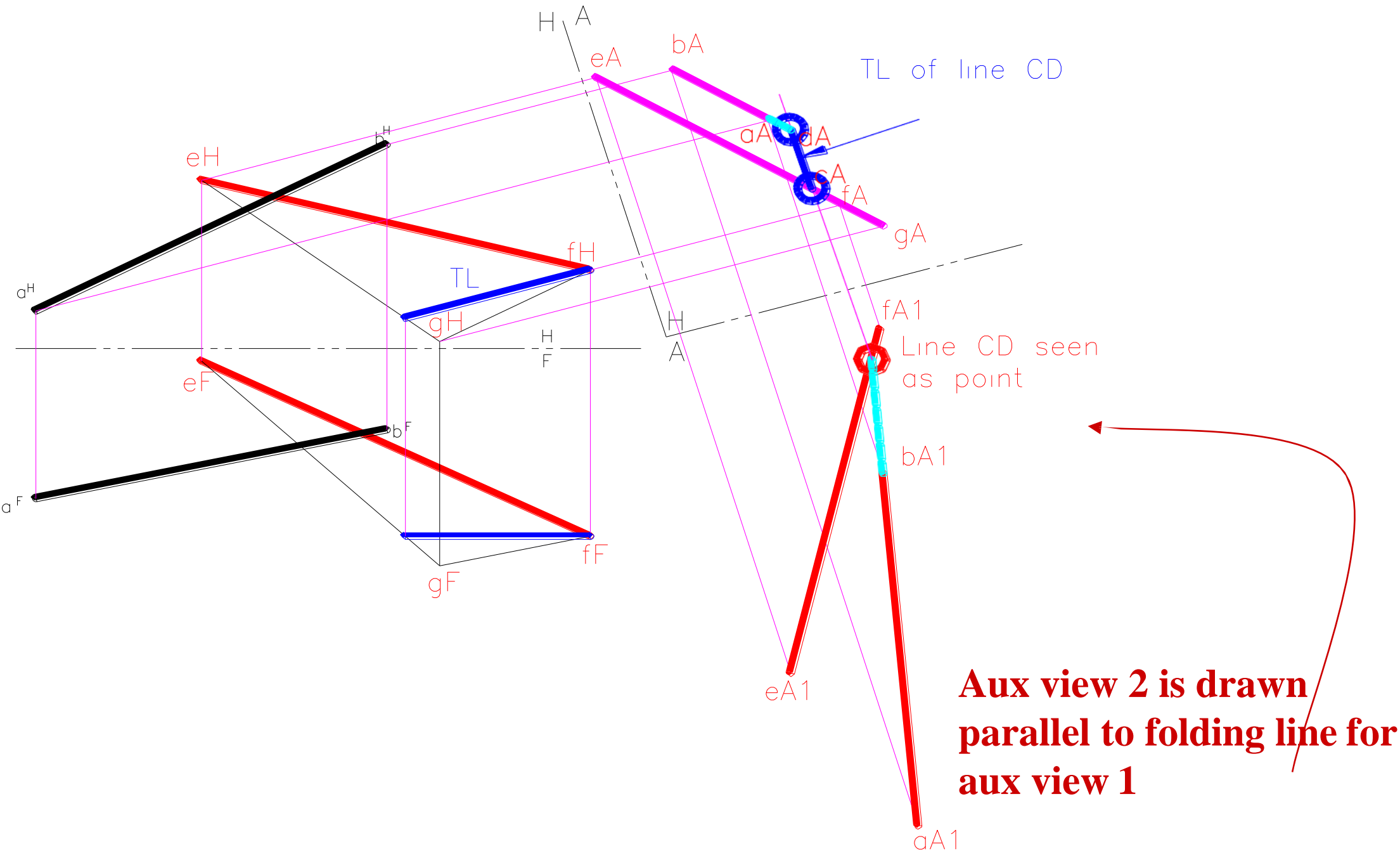

Shortest Horizontal Line between two given skew lines - Plane Method

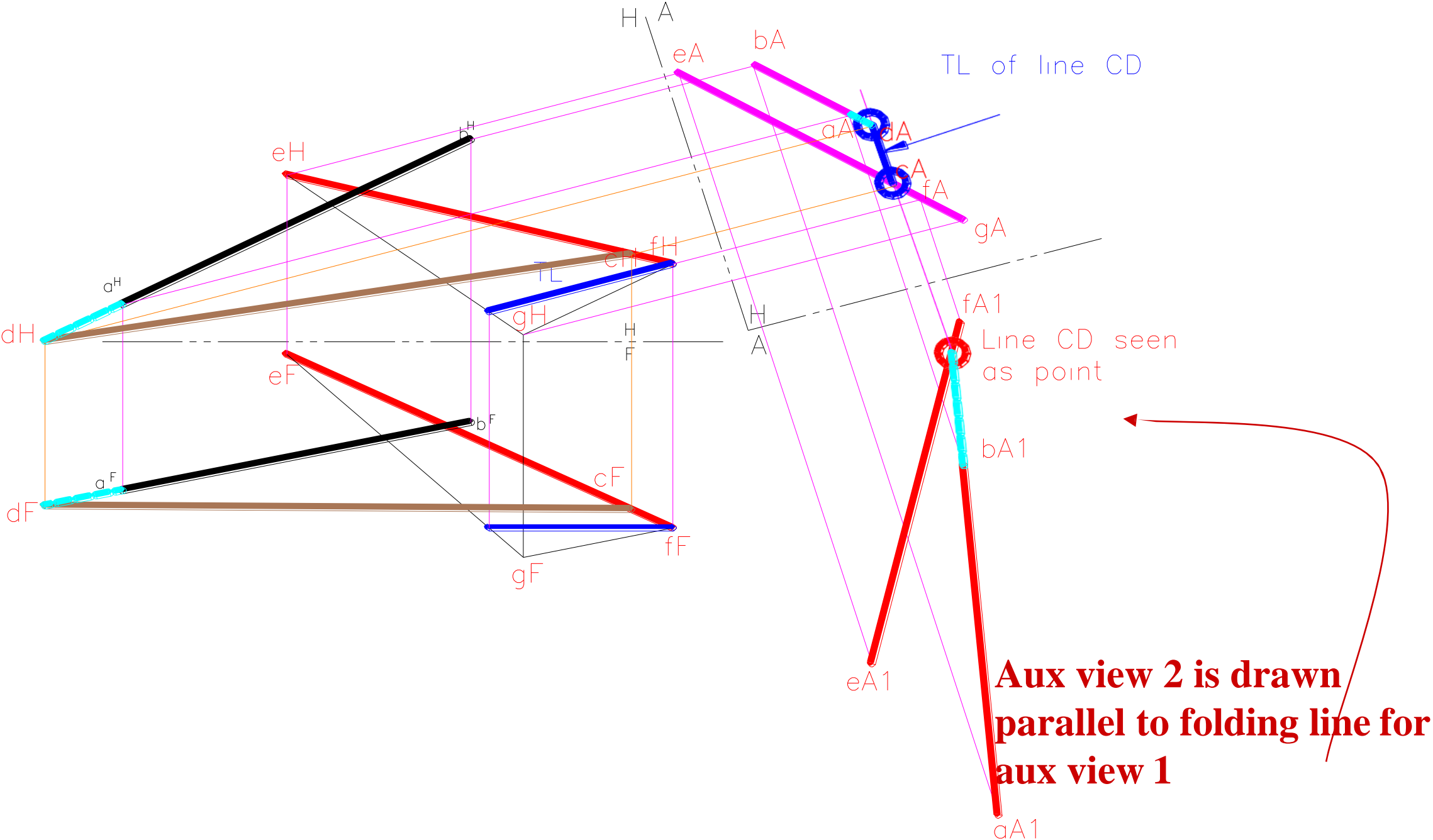

Shortest Horizontal Line between two given skew lines - Plane Method

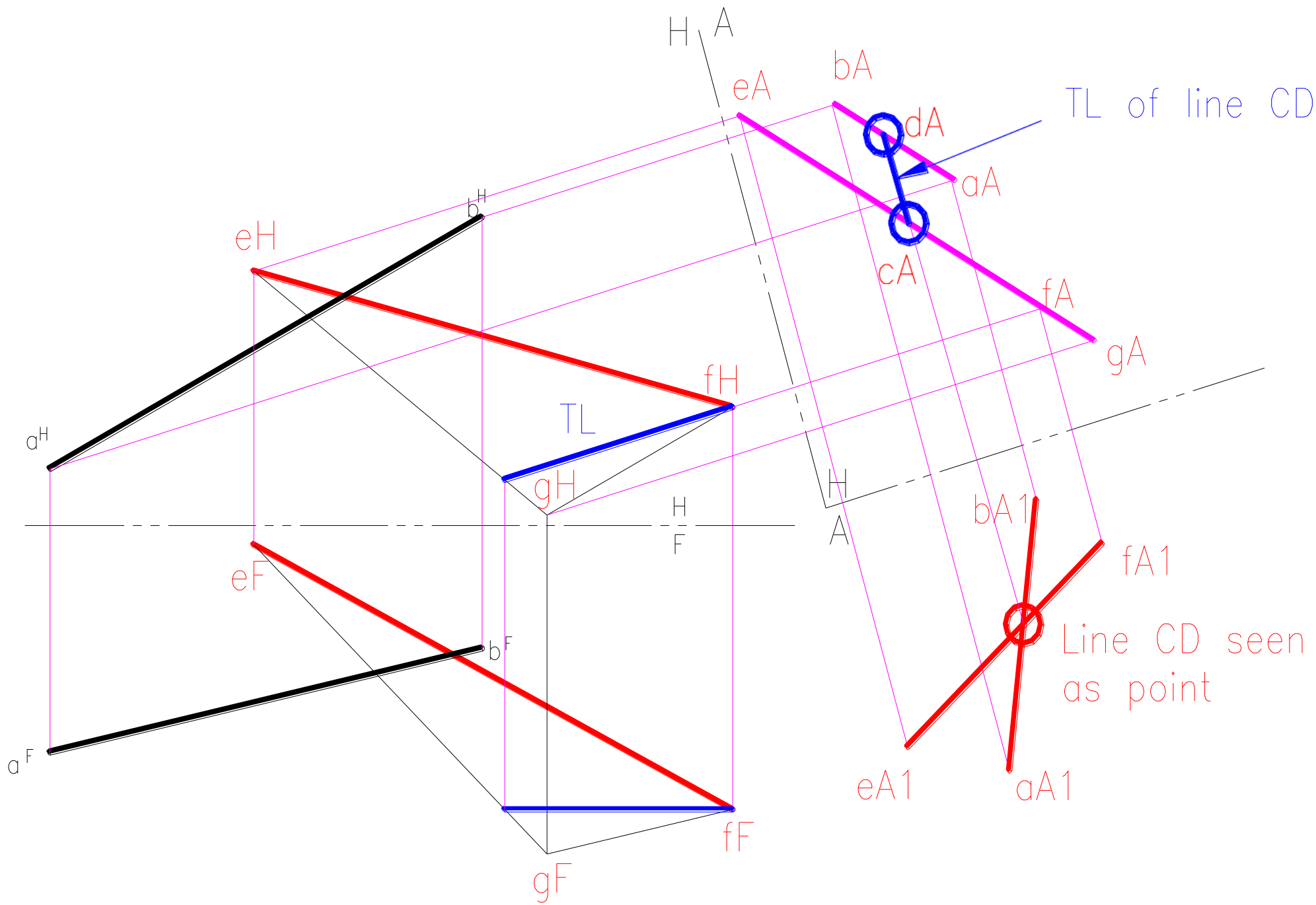

Shortest Horizontal Line between two given skew lines - Plane Method

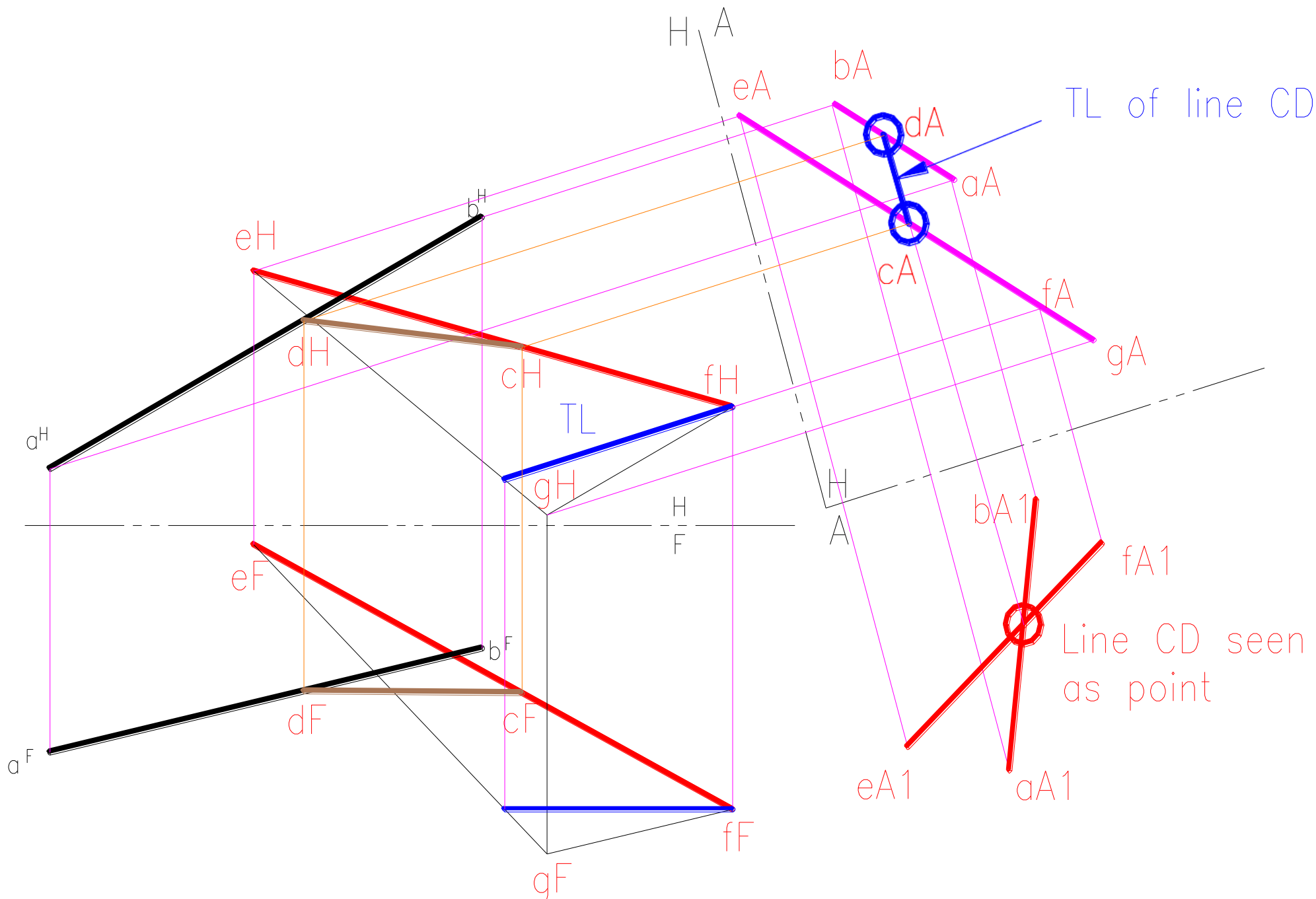

Shortest Grade Line between two given skew lines

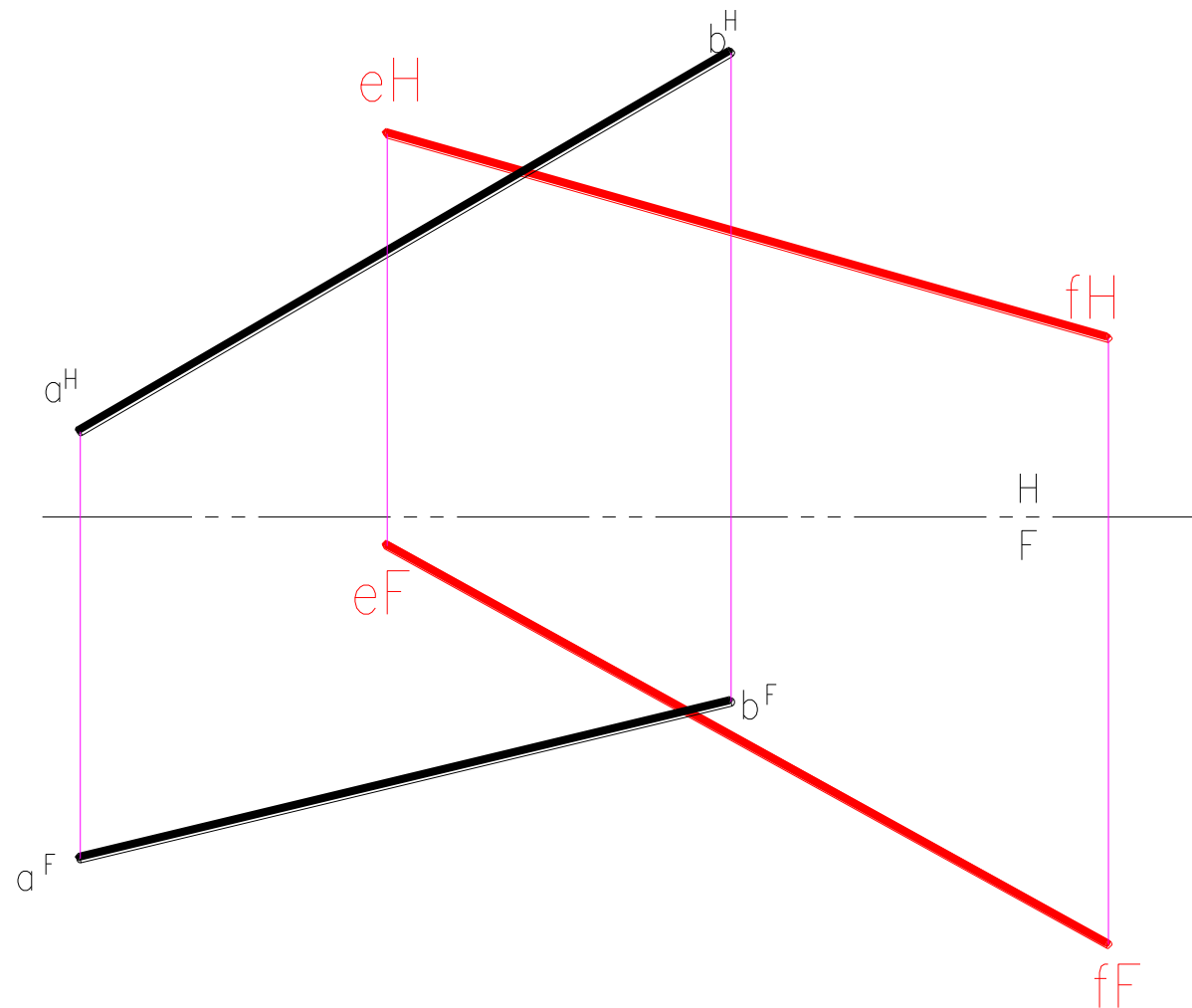

Shortest Grade Line between two given skew lines

Plane EFG is completed in such a way that line FG is parallel to skew line AB. The edge view of this plane is parallel to AB.

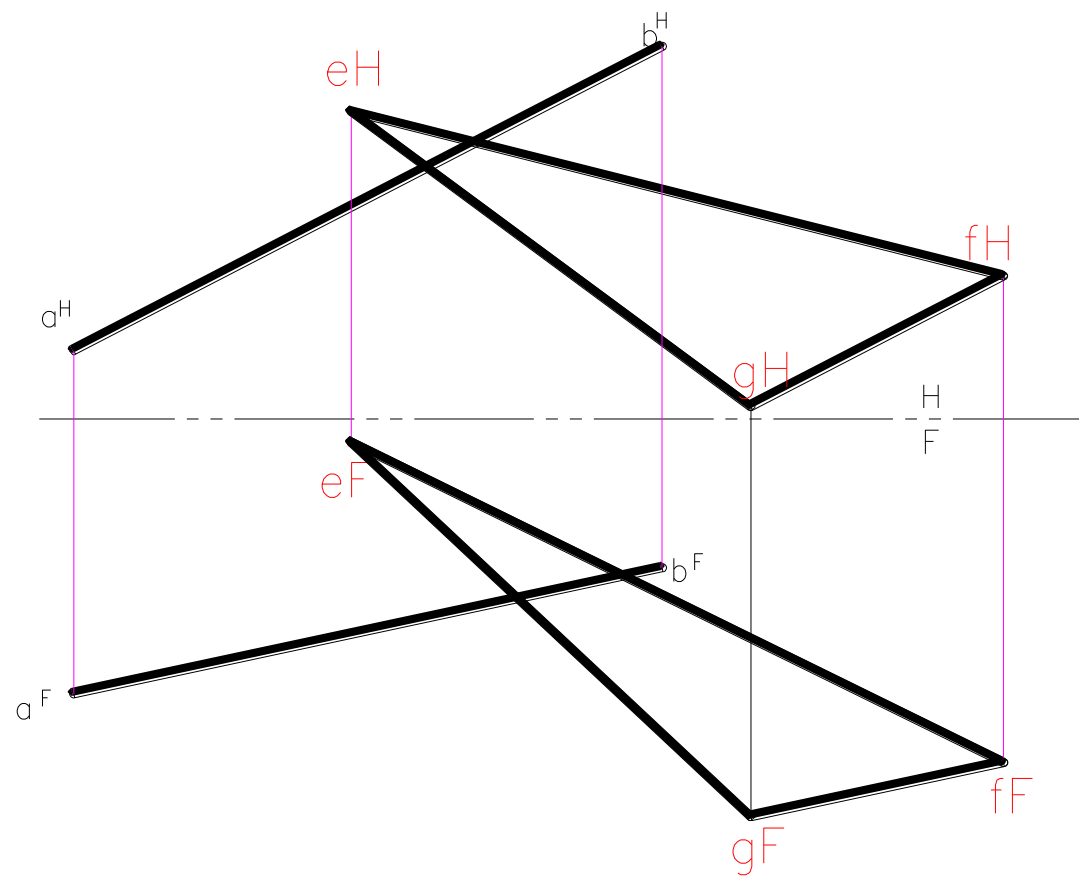

Shortest Grade Line

between two given skew lines.

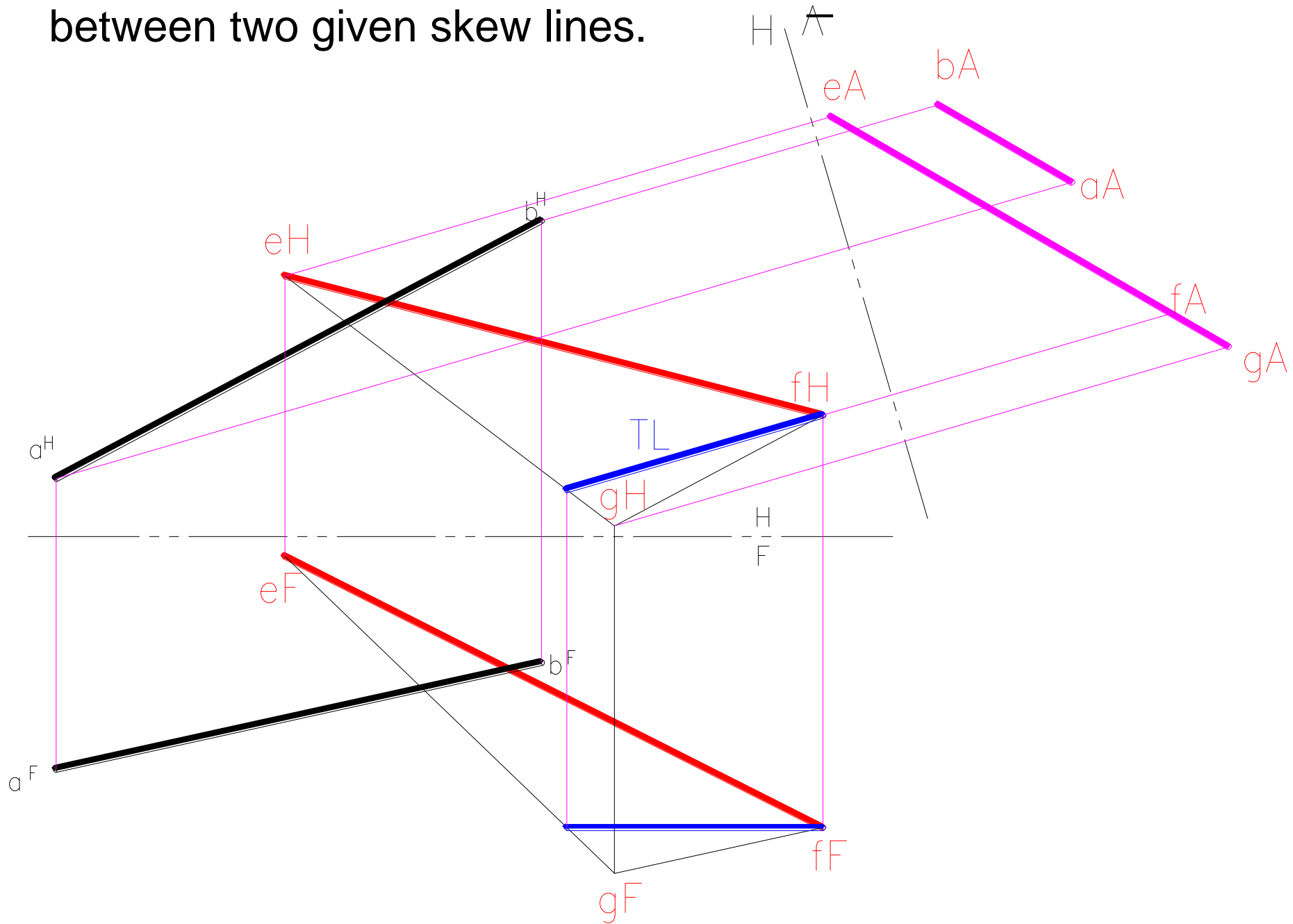

Shortest Grade Line

between two given skew lines.

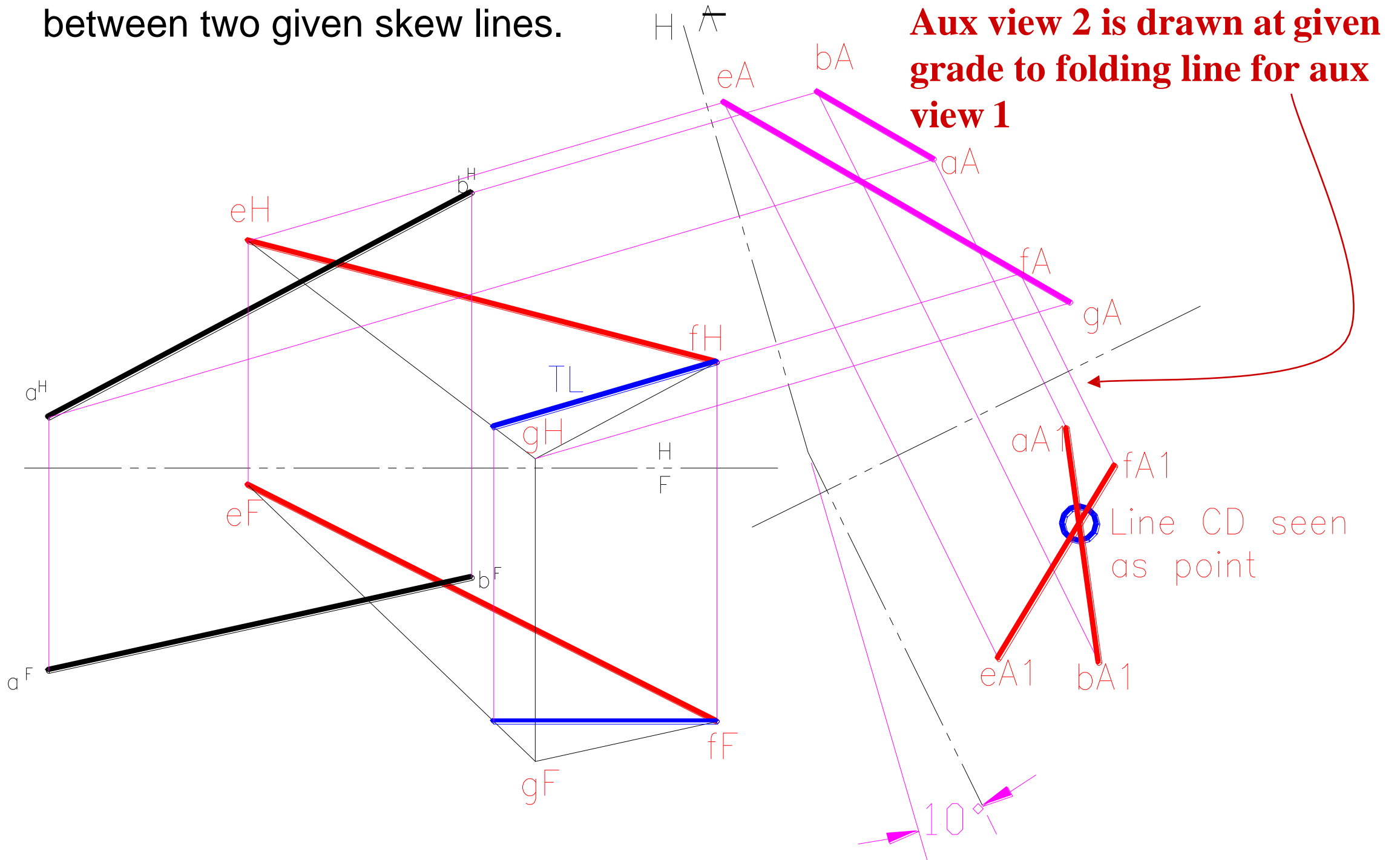

Shortest Grade Line

between two given skew lines

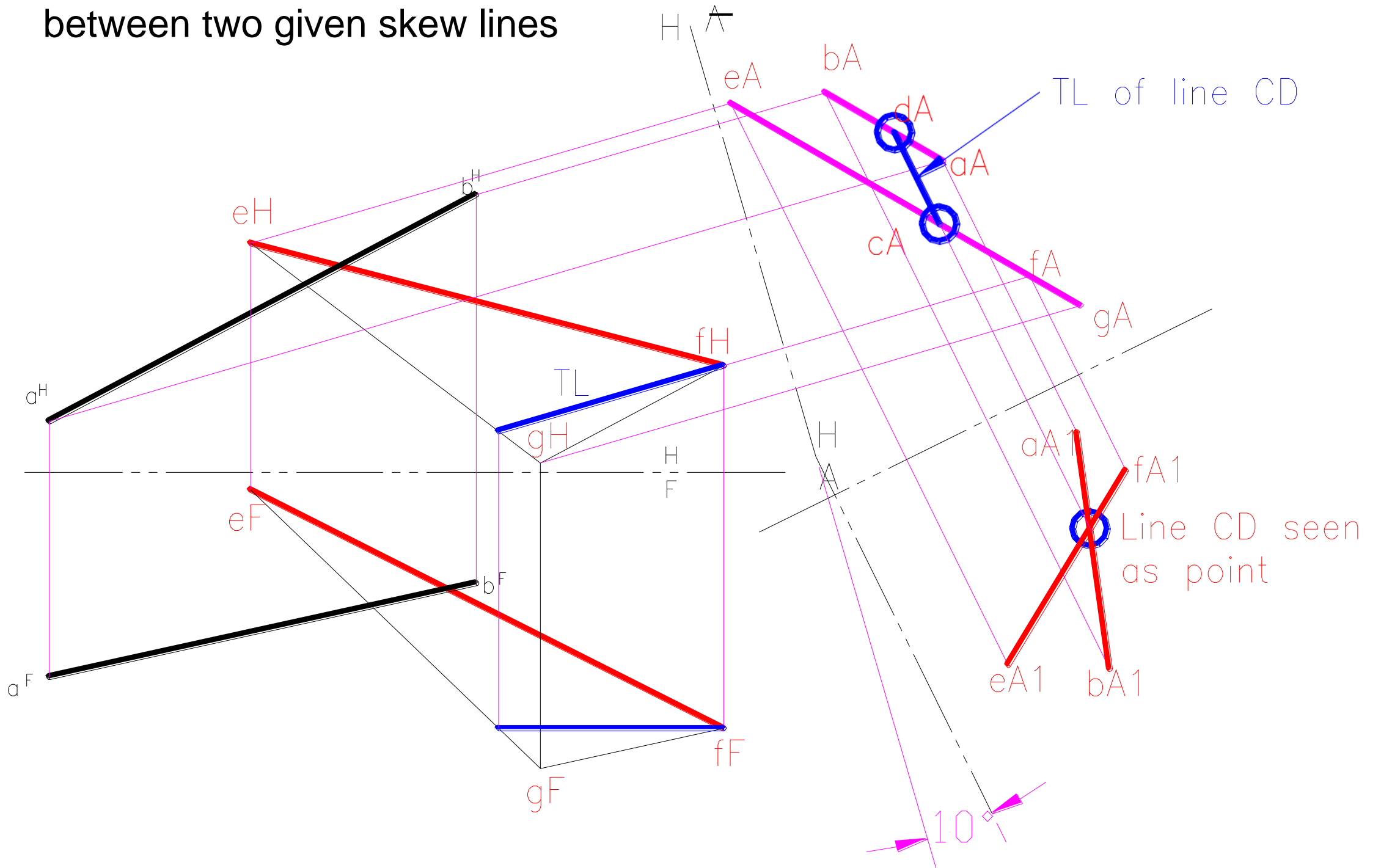

Shortest Grade Line

between two given skew lines

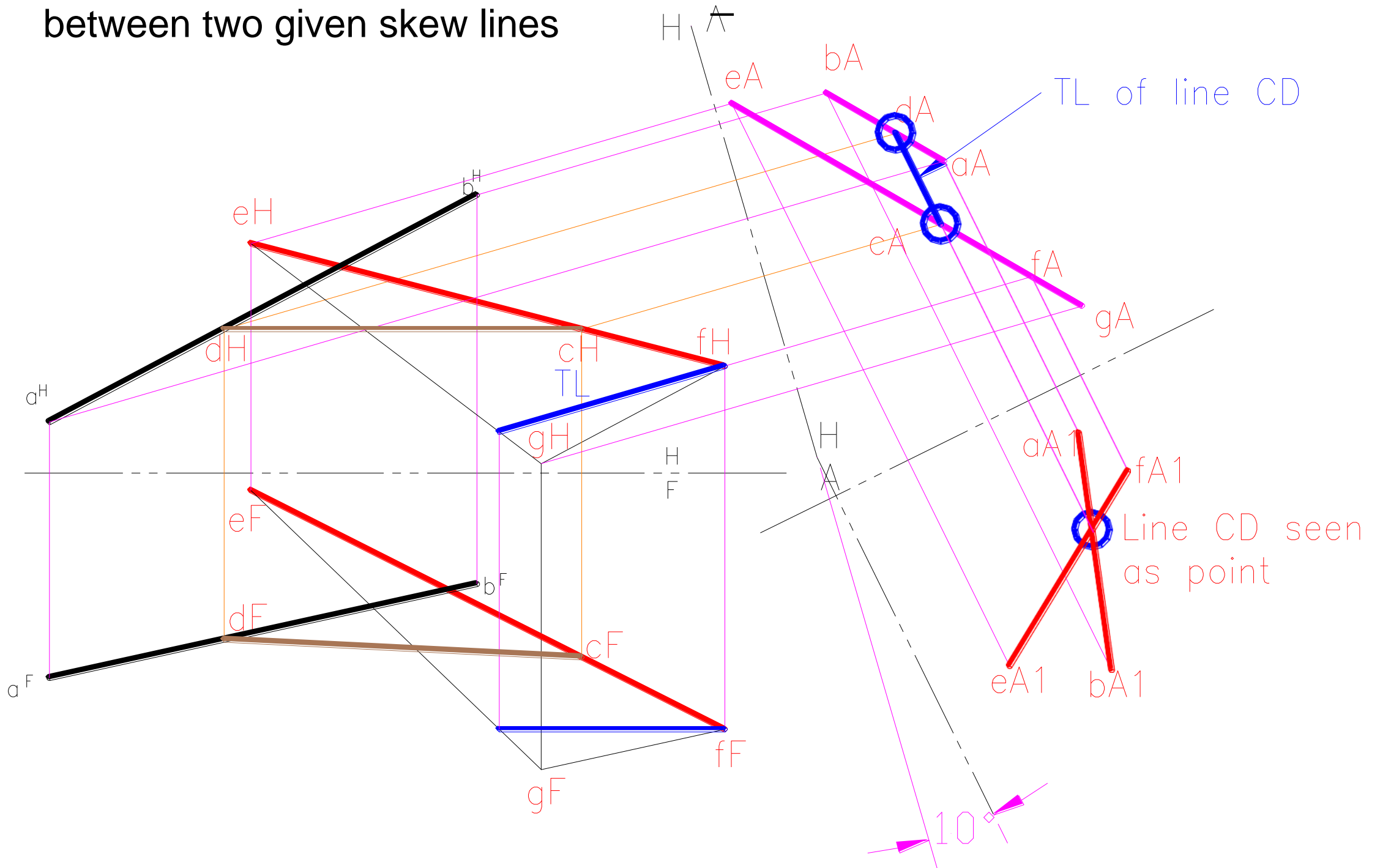

Shortest grade line between two skew lines

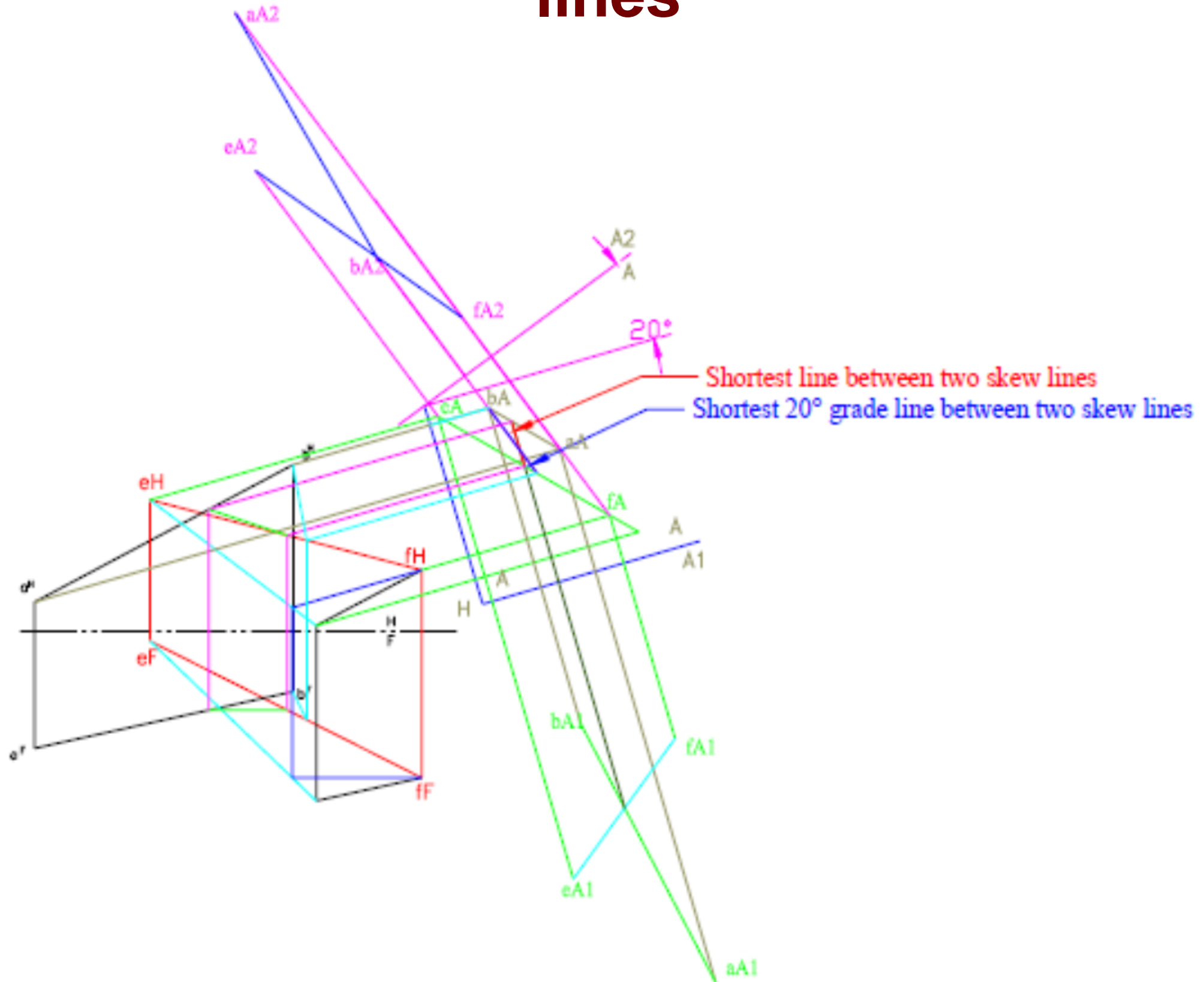

Relative position of a line to a plane

A line could be positioned relative to a plane as:

- 1) Parallel (EF)
- 2) Intersecting (RS)
- 2) Contained (MN)

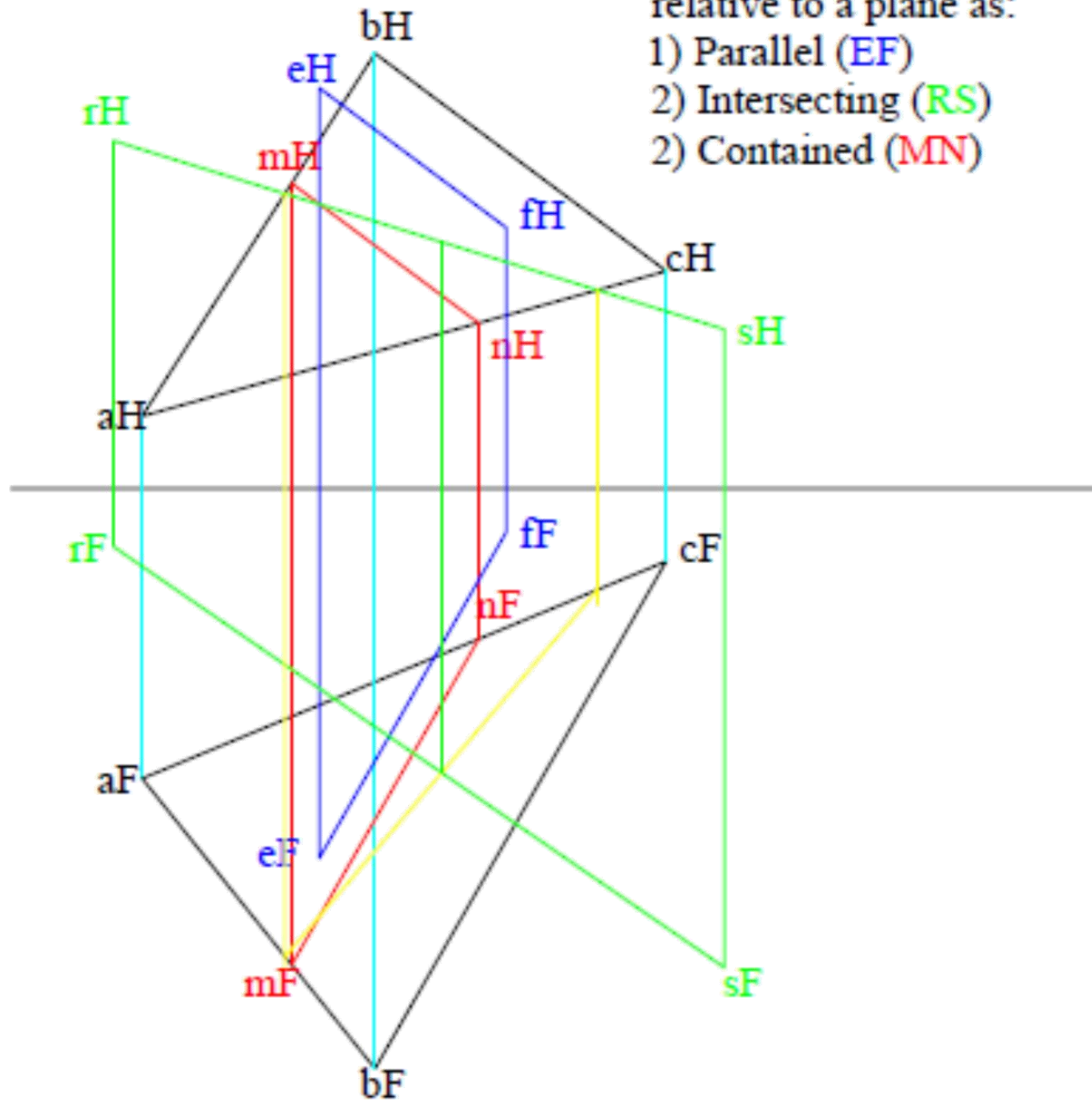

Line parallel to a plane

A line parallel to a plane (EF) must be parallel to a line belonging to that plane (MN)

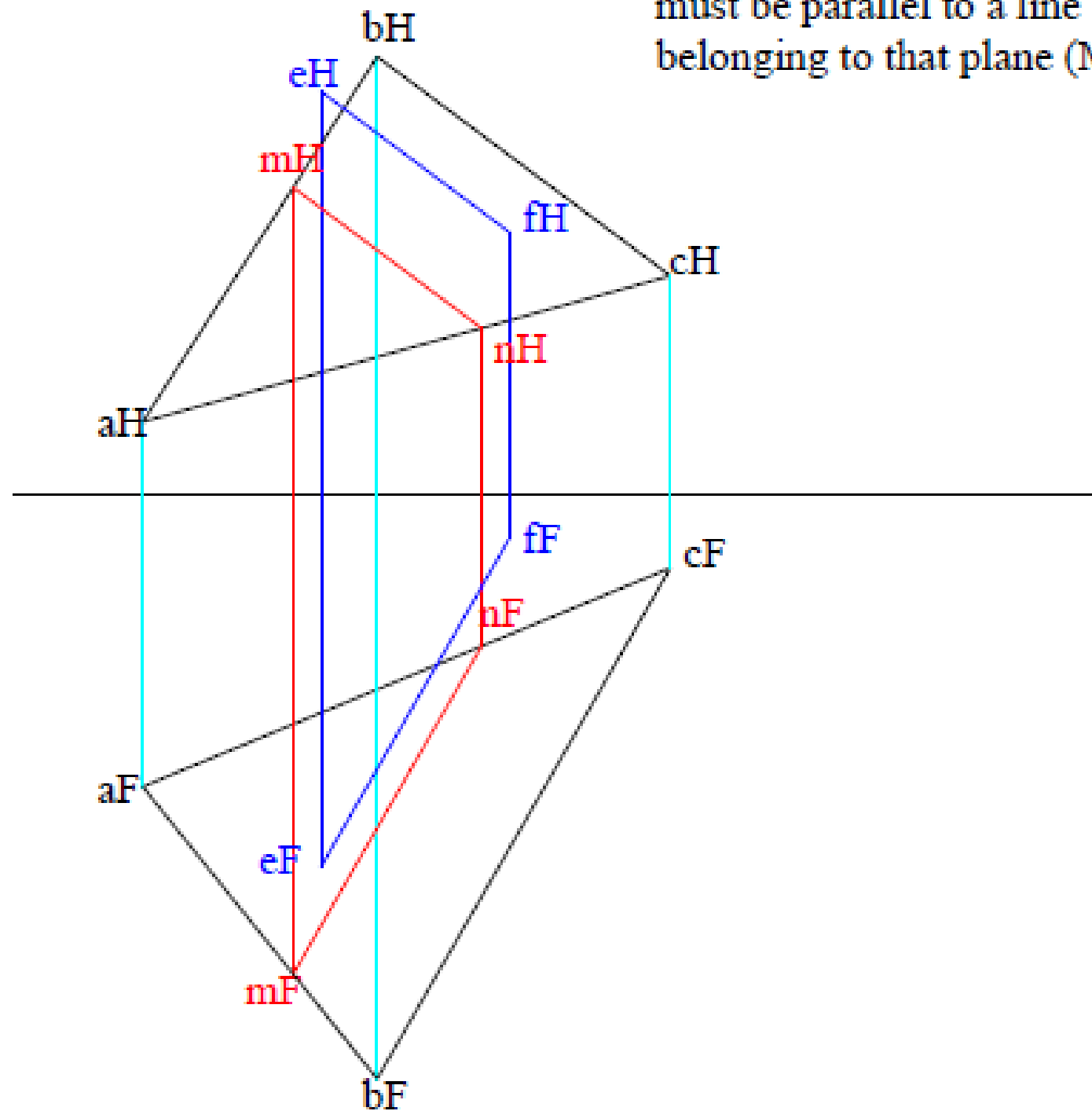

Line intersecting a plane

A line (RS) intersecting a plane (ABC) has a common point to that plane (J)

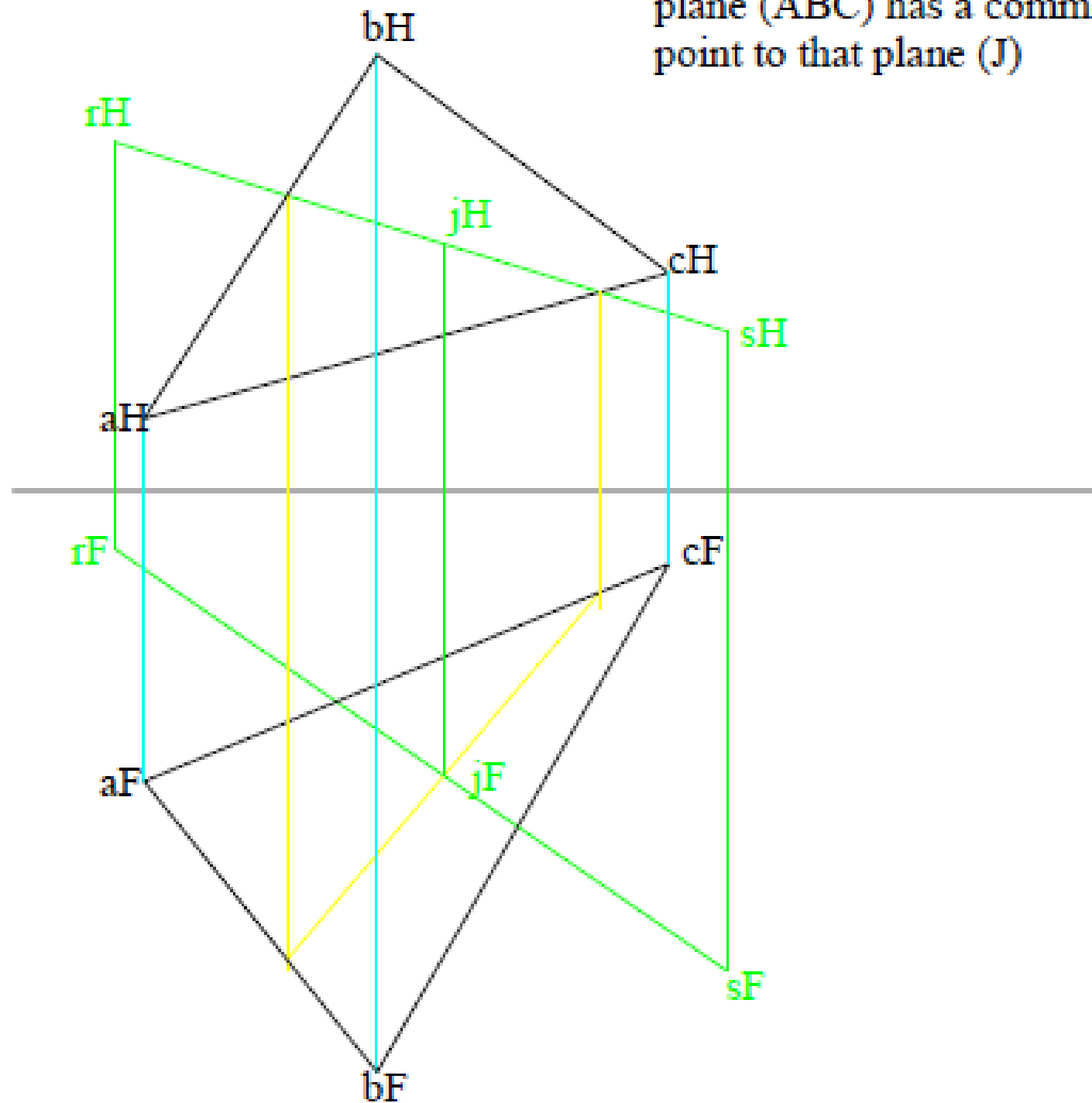

Line contained in a plane

A line contained (MN) in a plane has all the points belonging to that plane (ABC)

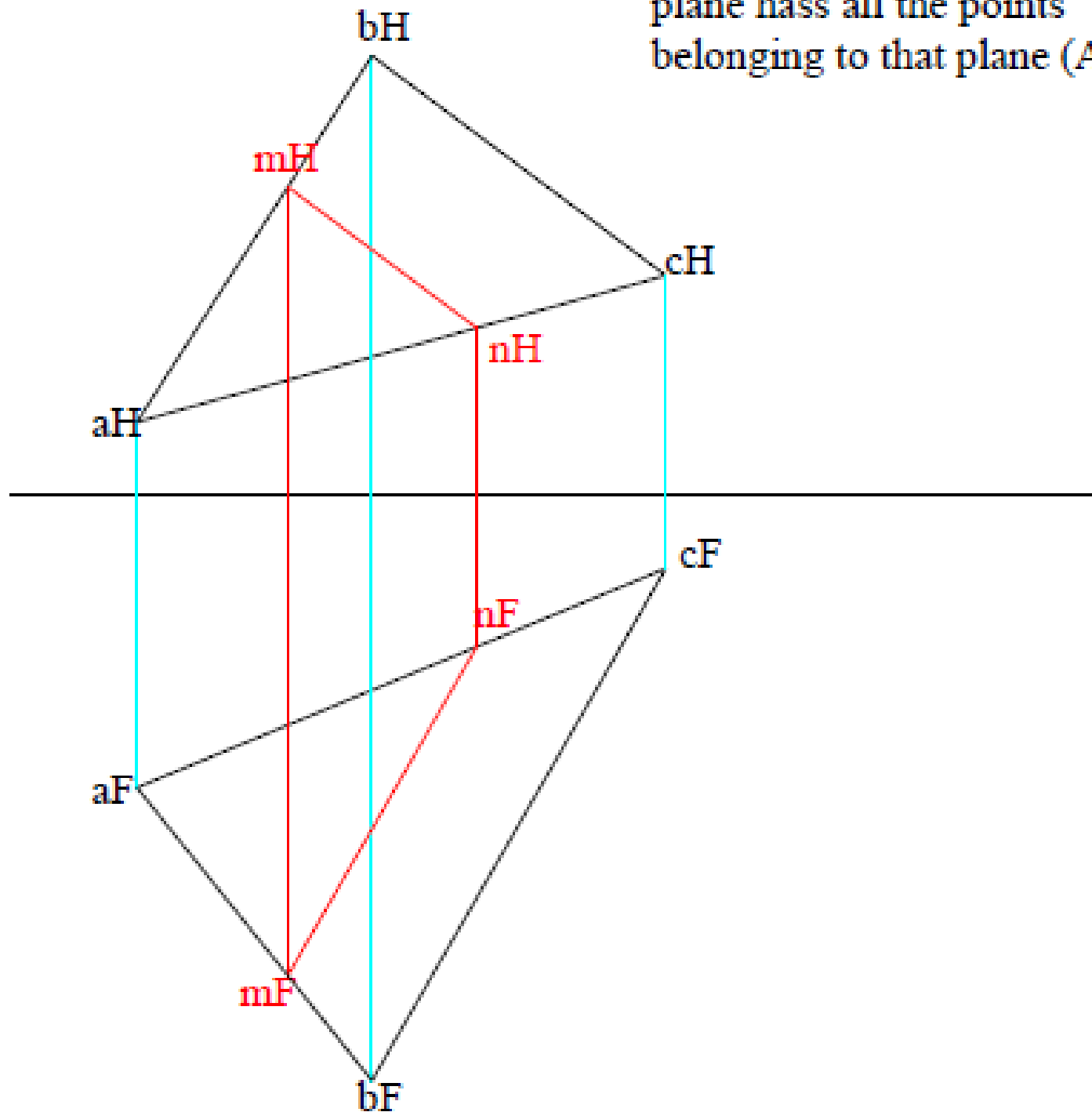

Intersection of line with plane – CP Cutting Plane Method to see piercing points

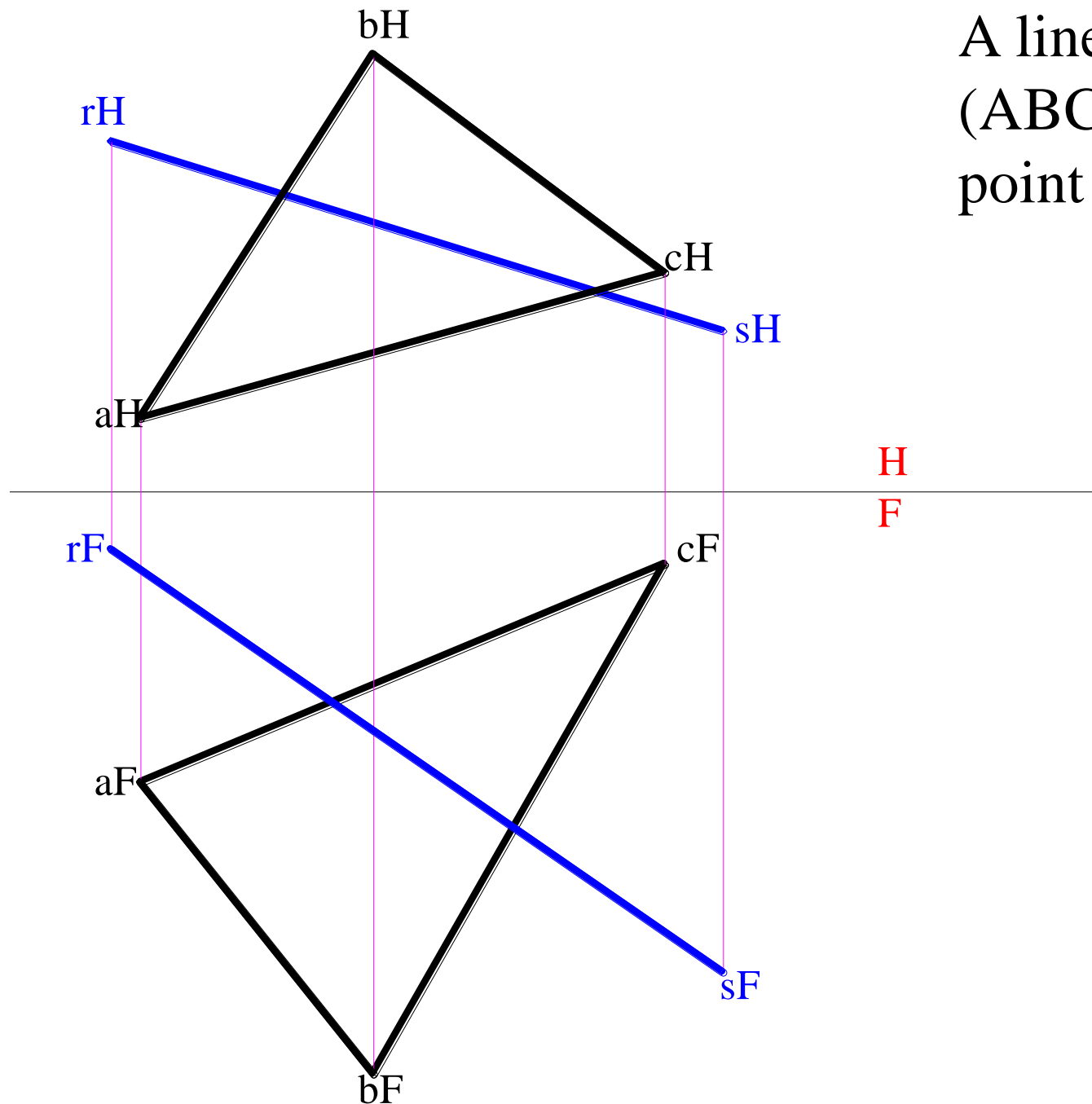

A line (RS) intersecting a plane (ABC) must have a common point to that plane

Intersection of line with plane – CP

Cutting Plane Method to see piercing points

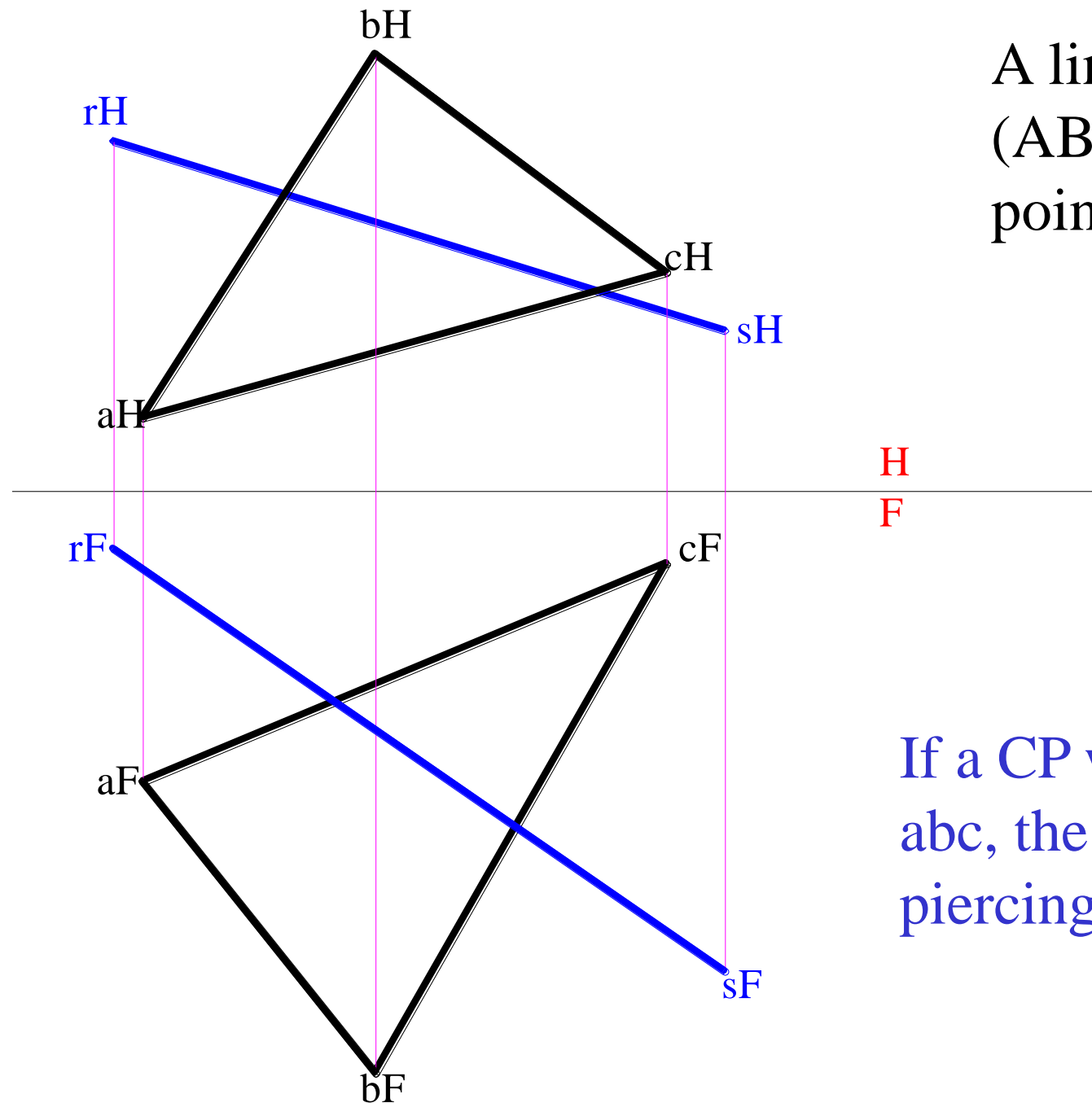

A line (RS) intersecting a plane (ABC) must have a common point to that plane

If a CP with line RS is introduced to cut abc, the line RS will intersect at piercing point with abc.

Intersection of line with plane – CP

Cutting Plane Method to see piercing points

A line (RS) intersecting a plane (ABC) must have a common point to that plane

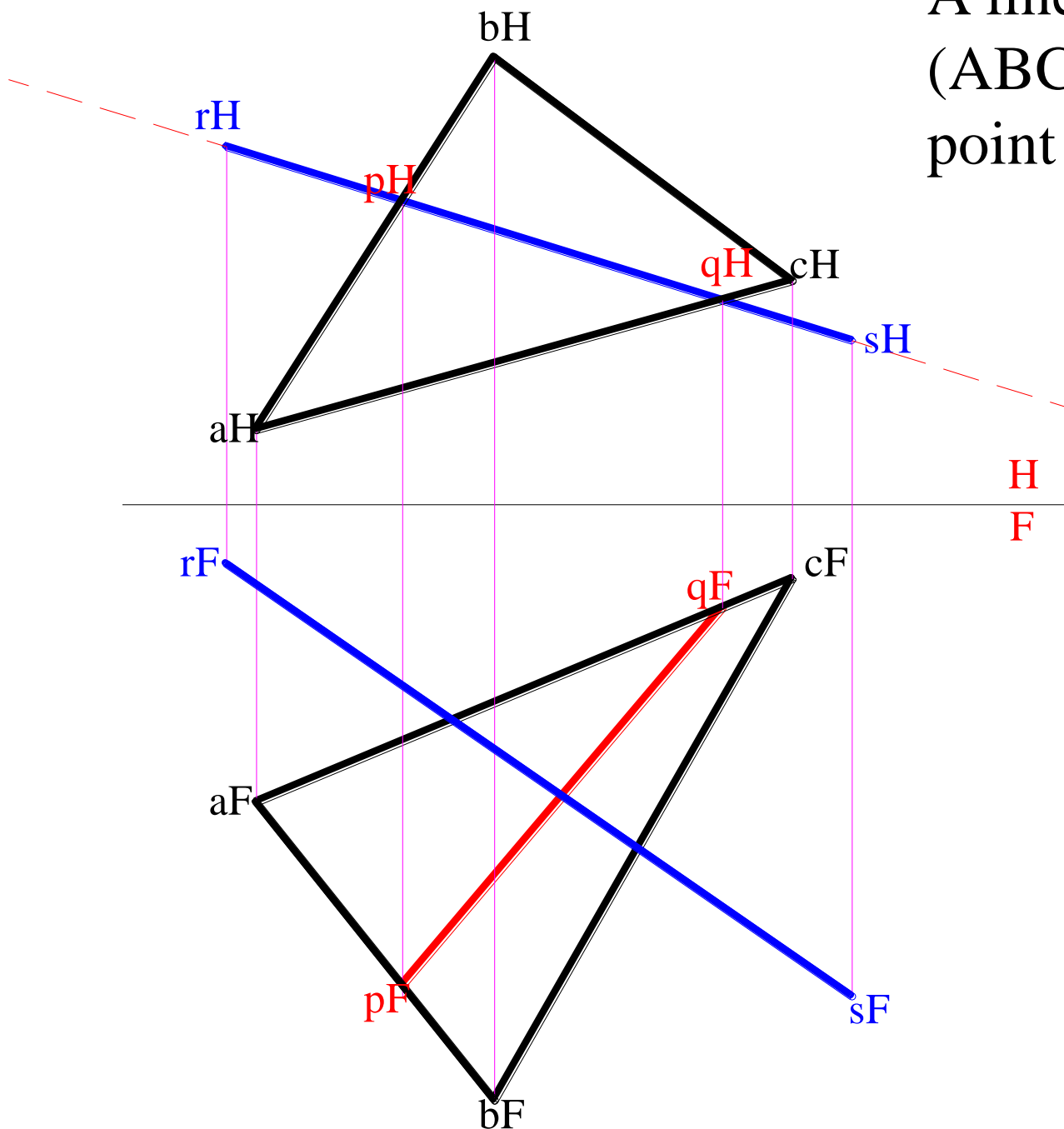

add a **cutting plane** whose edge view coincides with line RS in the top view

- Line RS is in the plane since the EV of CP coincides RS
- If the two lines are in a plane and if they are not parallel, they must intersect in the plane

Intersection of line with plane – CP

Cutting Plane Method to see piercing points

A line (RS) intersecting a plane (ABC) must have a common point to that plane

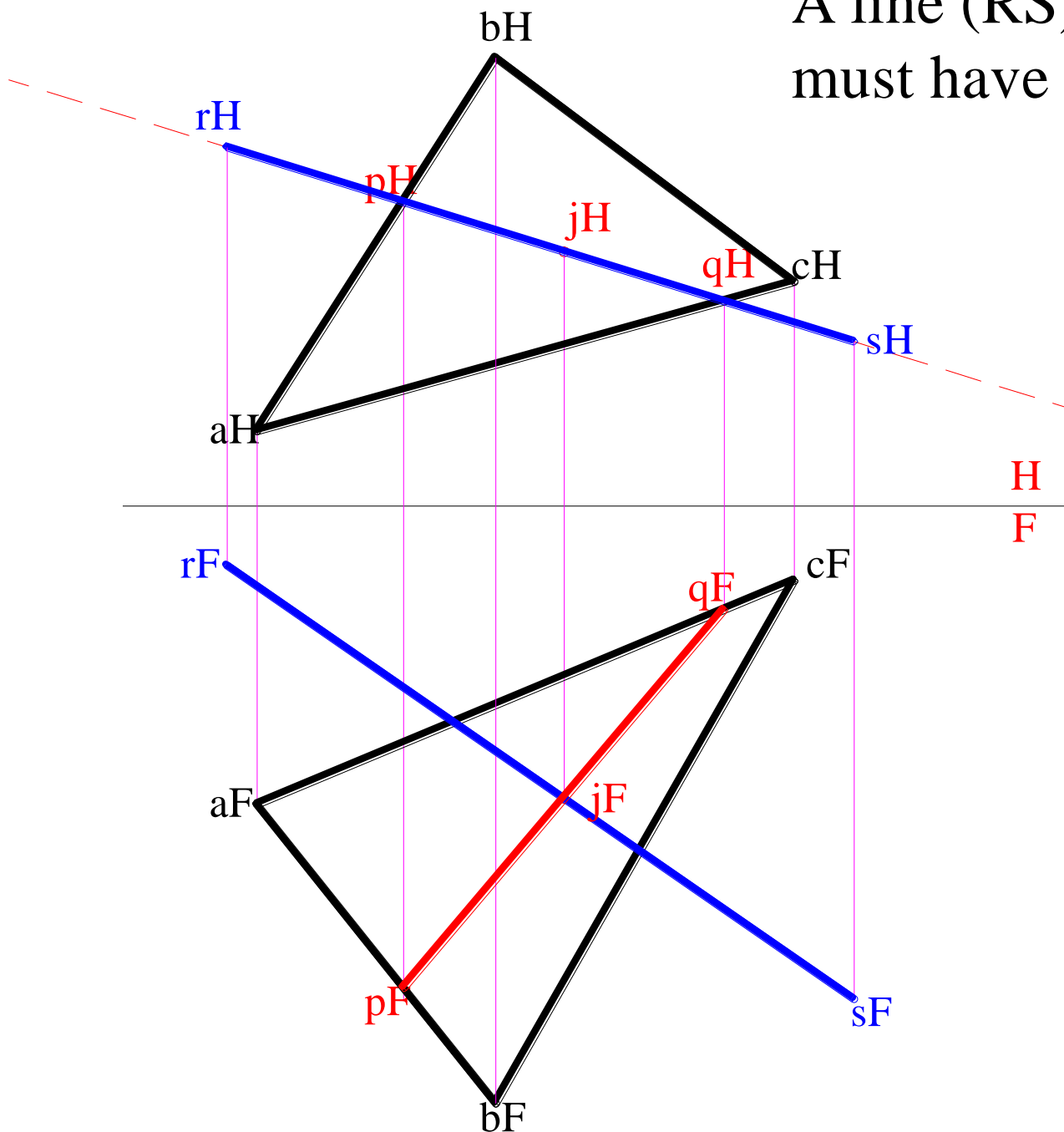

add a **cutting plane** whose edge view coincides with line RS in the top view

the point of intersection between the **line RS** and the projection of the **CP** in the front view will give the common point between the **line RS** and the plane abc. The point J is the piercing point

Intersection of line with plane – CP

Cutting Plane Method to see piercing points

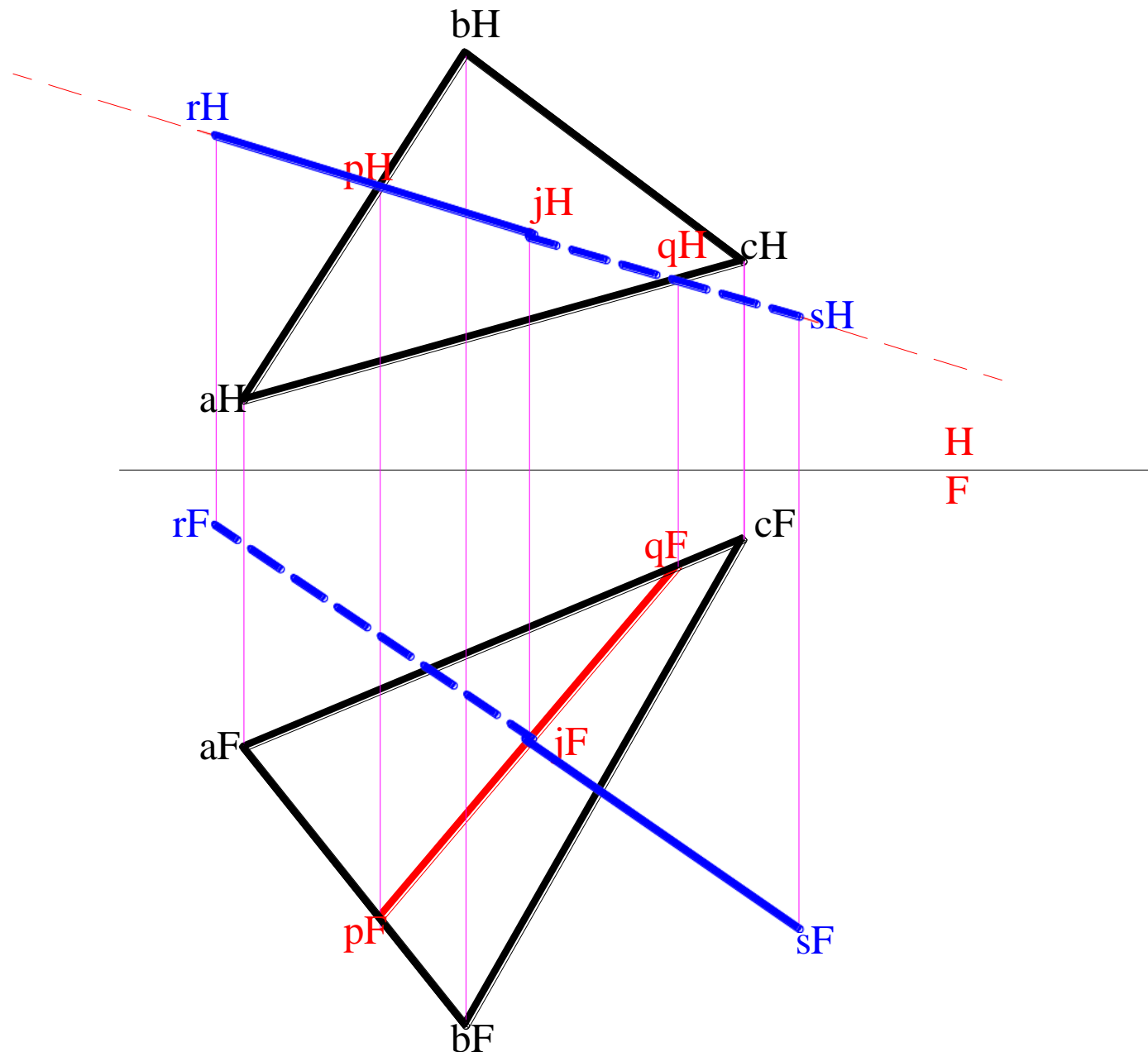

Information about the visibility in a view will be collected in any adjacent view.

The corner or edge farthest from the observer will usually be hidden if it lies within the outline of the view.

The corner or edge of the object nearest to the observer will be visible.

Intersection of line with plane – CP

Cutting Plane Method to see piercing points

Rule of Visibility

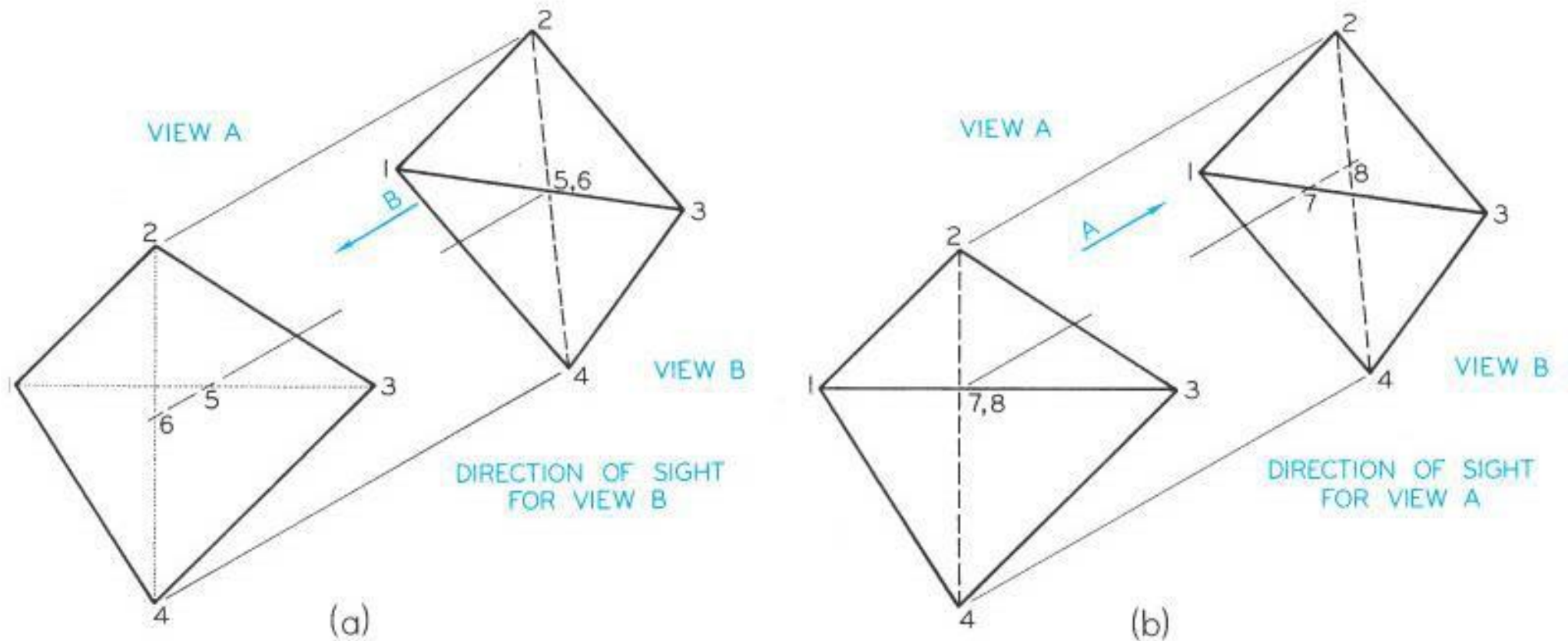

- Information about visibility is collected in adjacent view
- Point 5 on edge 1-3 is nearer to the observer. So edge 1-3 is visible in view B
- Point 7 on edge 1-2 is nearer to the observer. So edge 1-2 is visible in view A

Intersection of line with plane – EV

Edge View Method to see piercing points

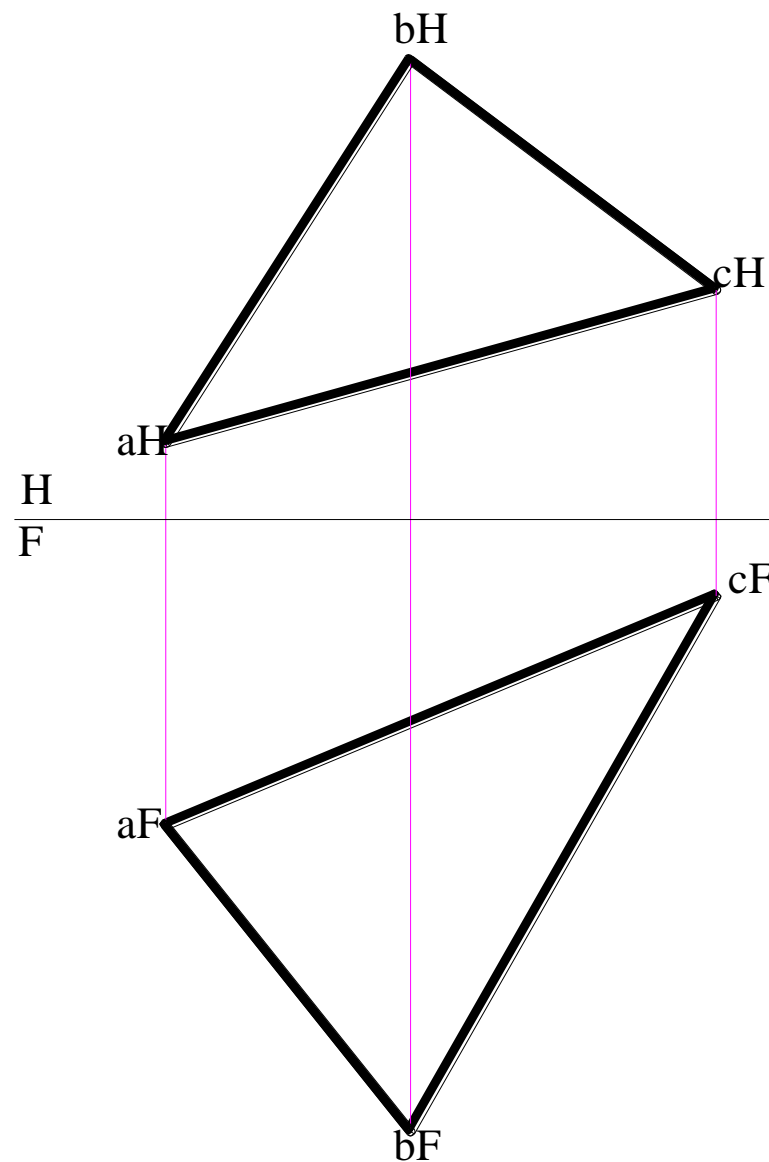

Intersection of line with plane – EV

Edge View Method to
see piercing points.

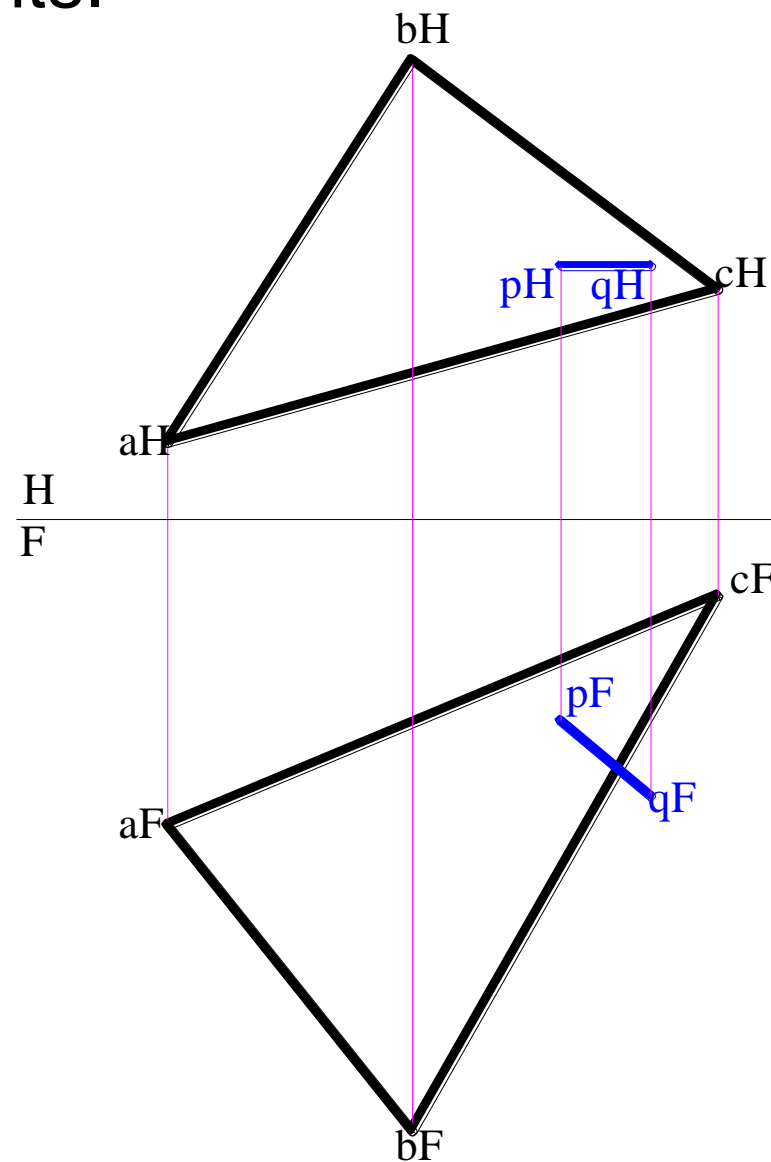

Intersection of line with plane – EV

Edge View Method
to see piercing
points.

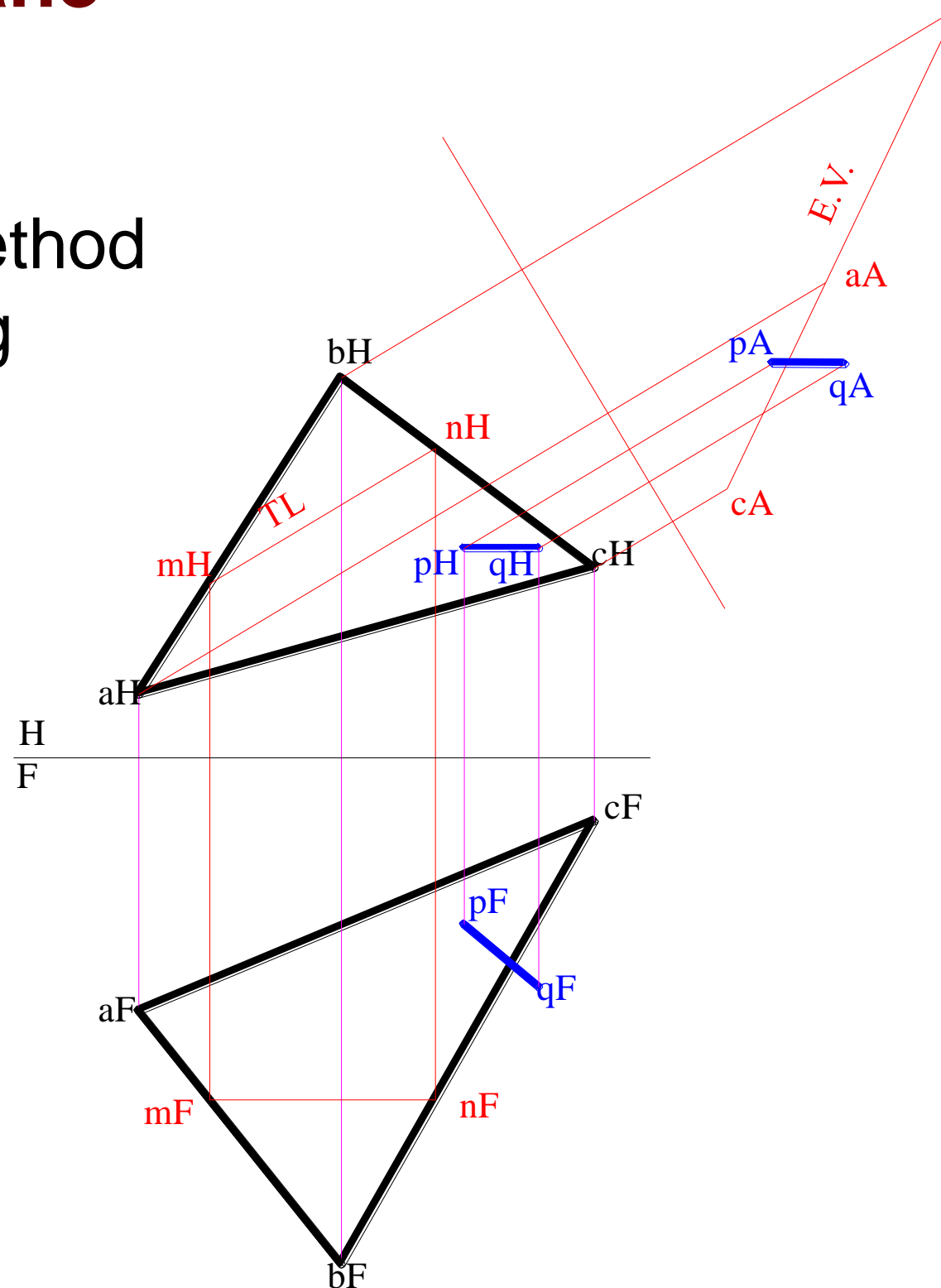

Intersection of line with plane – EV

Edge View Method
to see piercing
points.

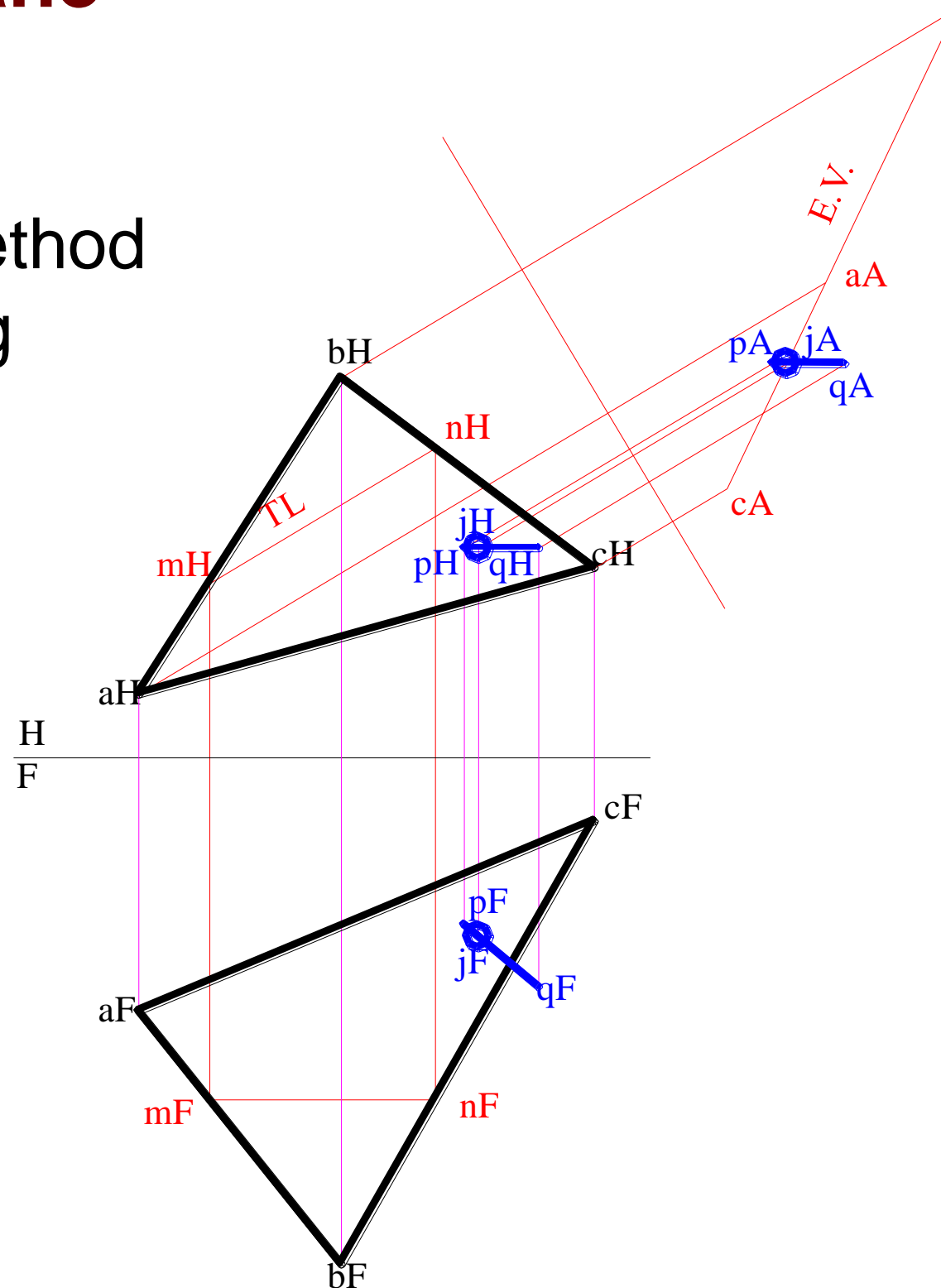

Intersection of two planes - EV Edge View Method

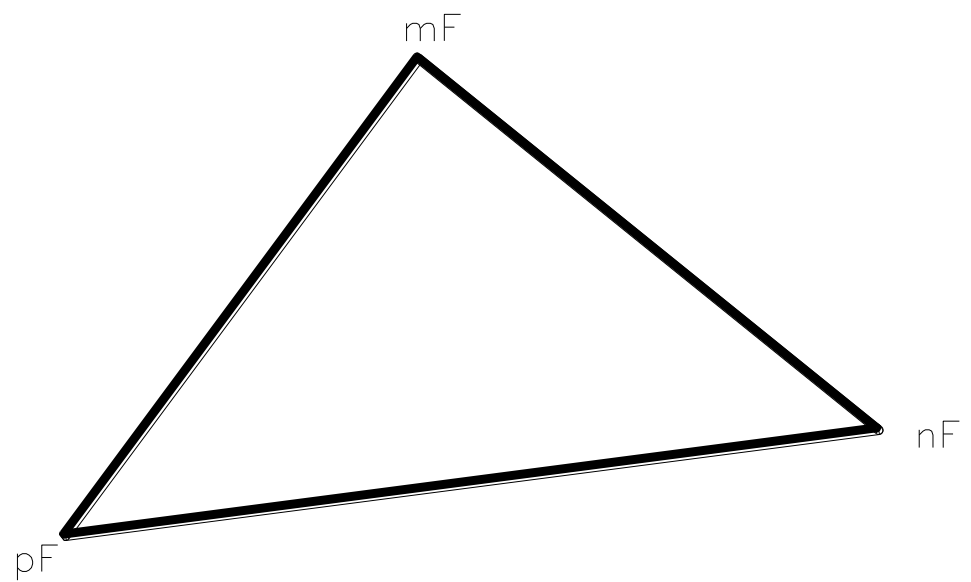
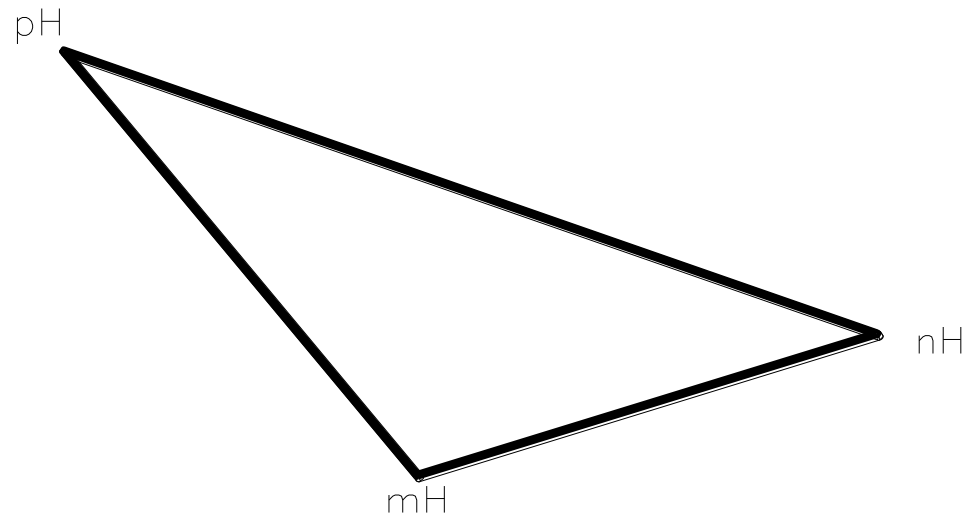

Intersection of two planes - EV Edge View Method

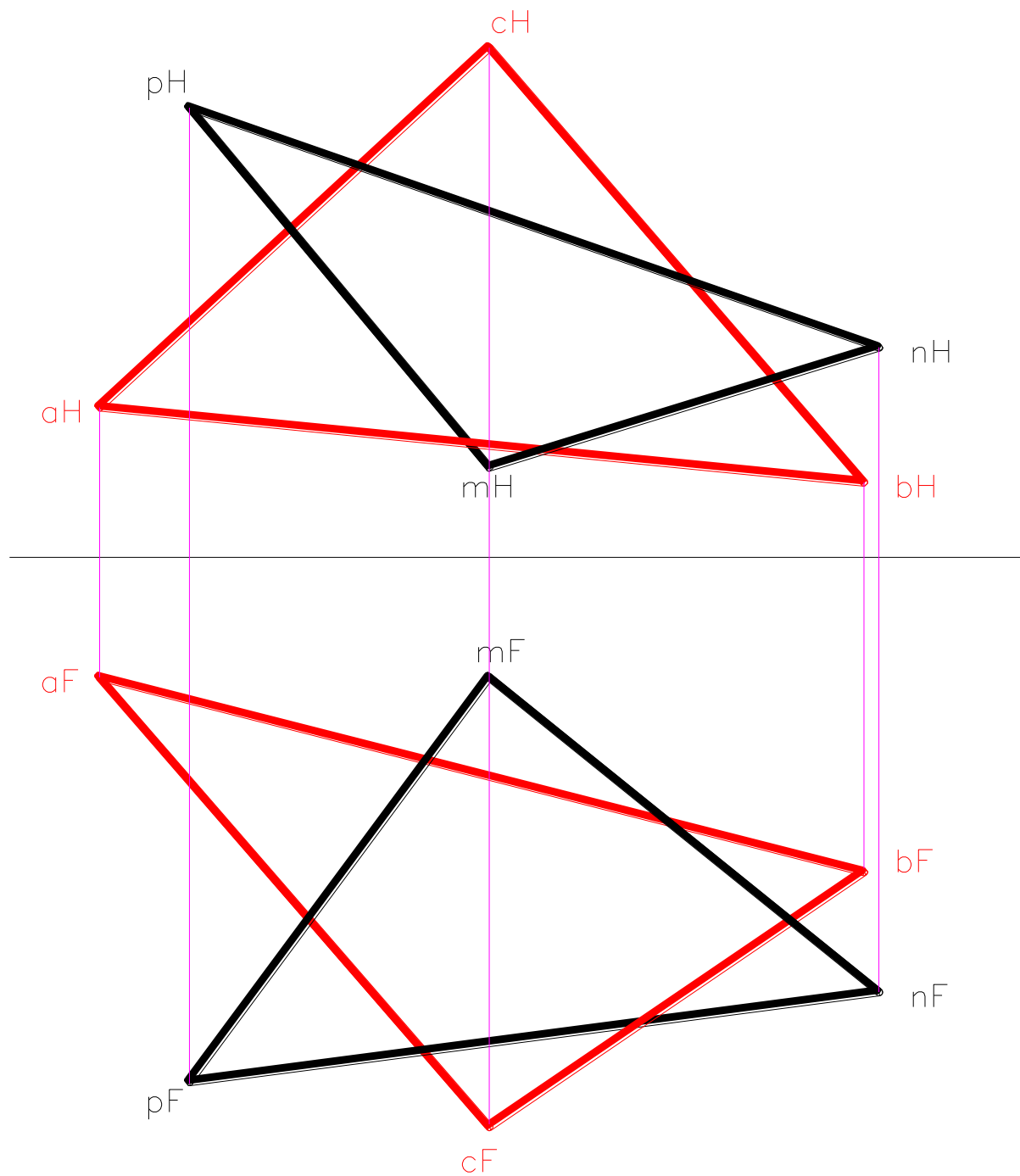

Intersection of two planes - EV Edge View Method

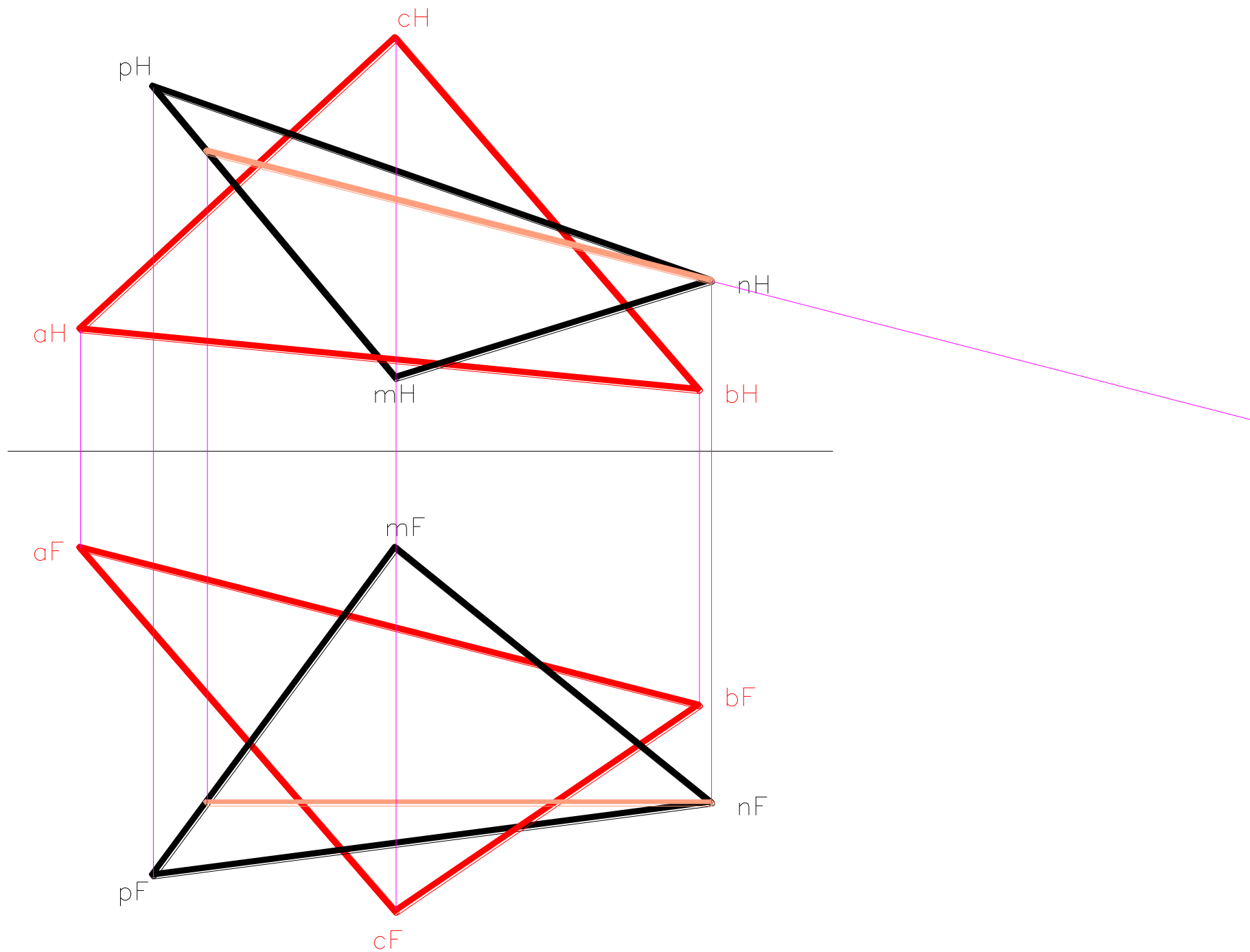

Intersection of two planes - EV Edge View Method

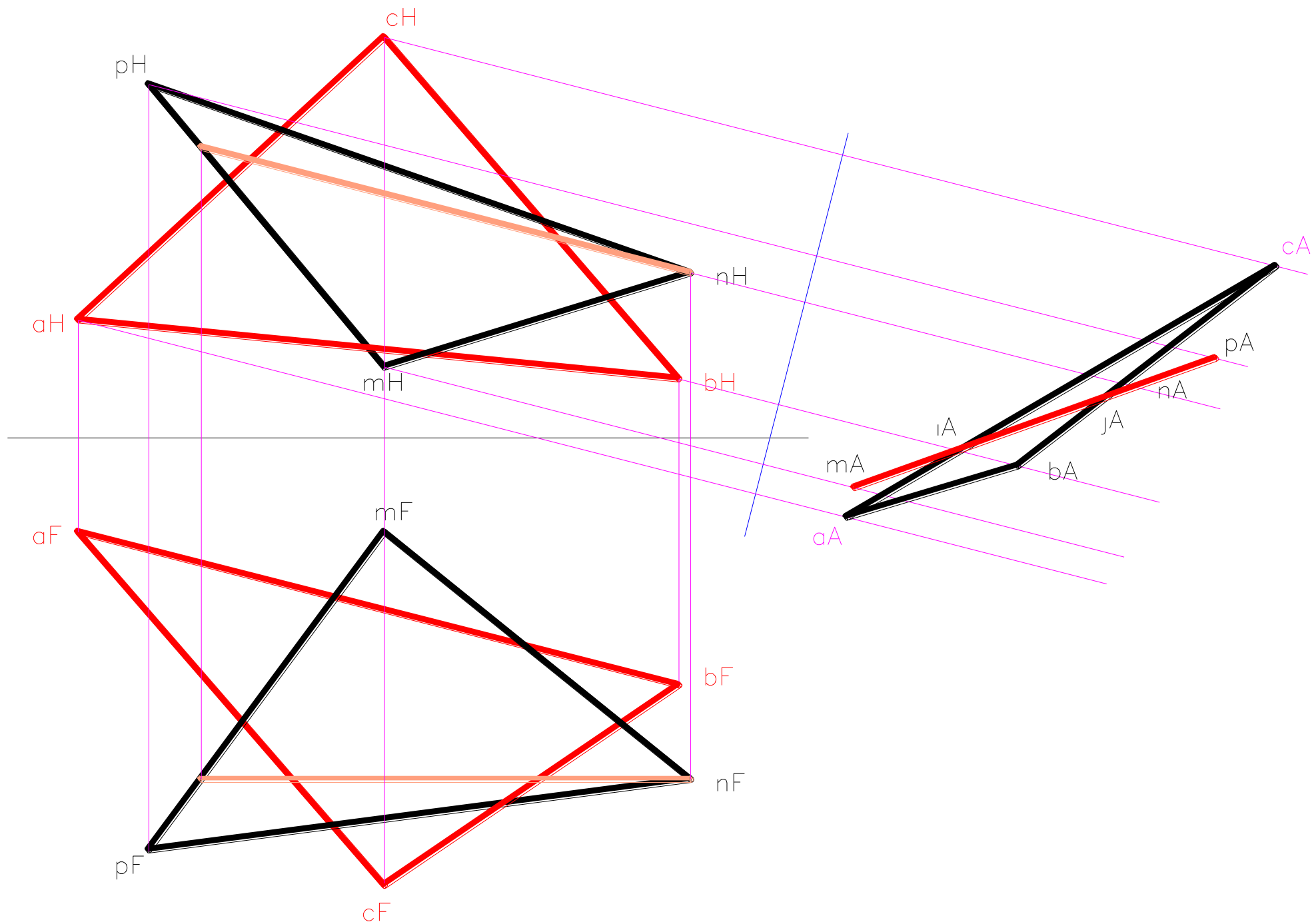

Intersection of two planes - EV Edge View Method

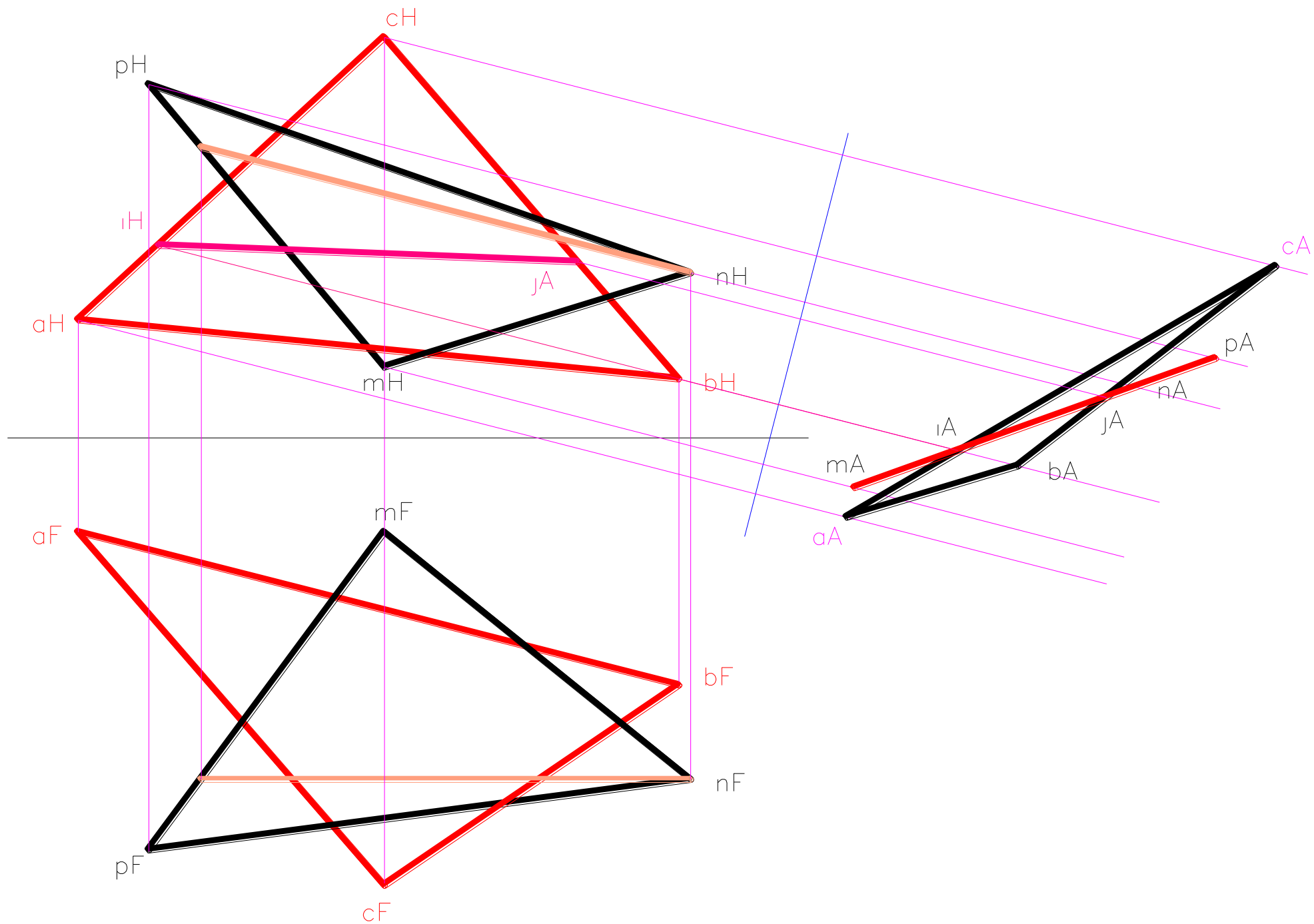

Intersection of two planes - EV Edge View Method

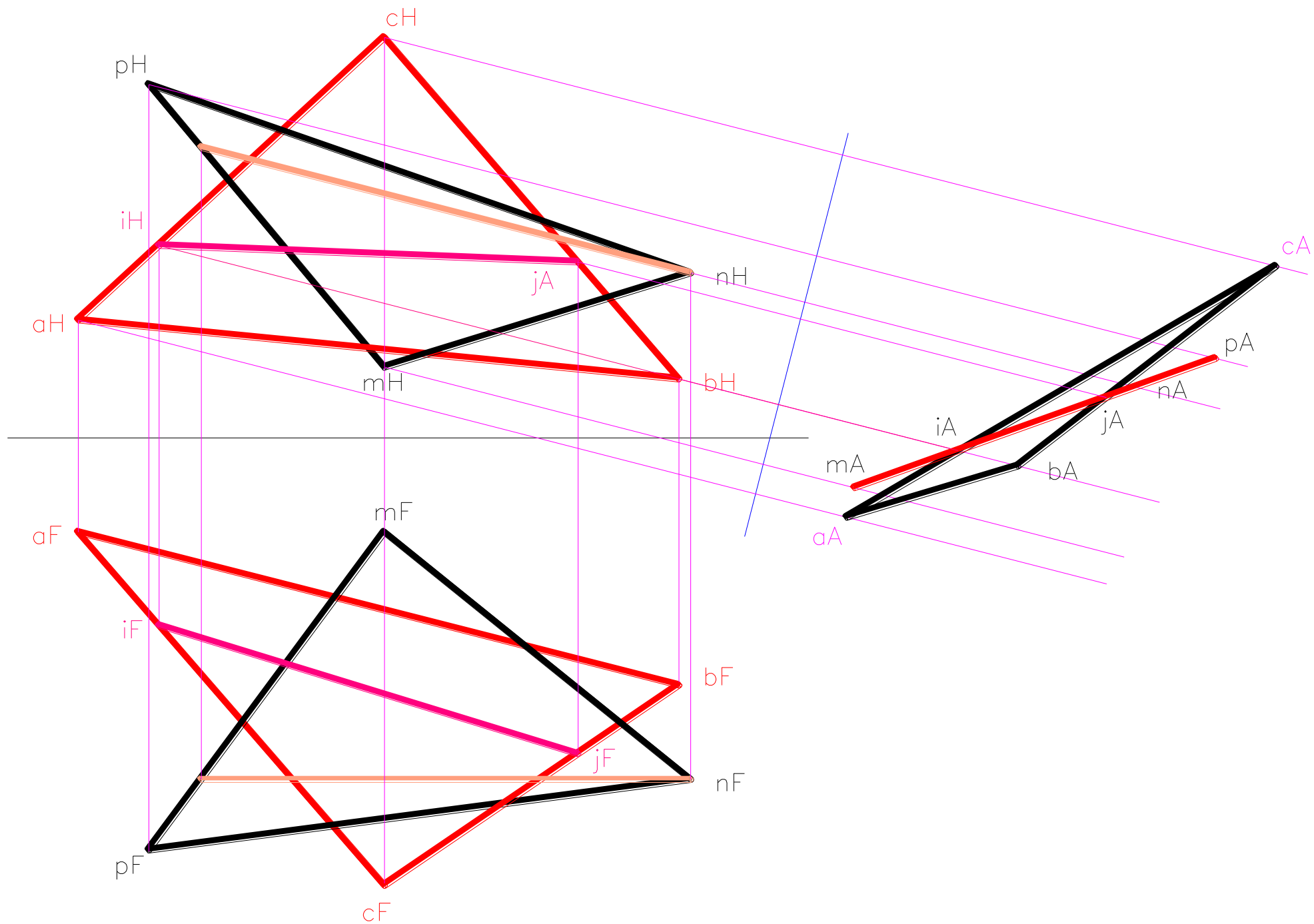

Intersection of two planes - EV Edge View Method

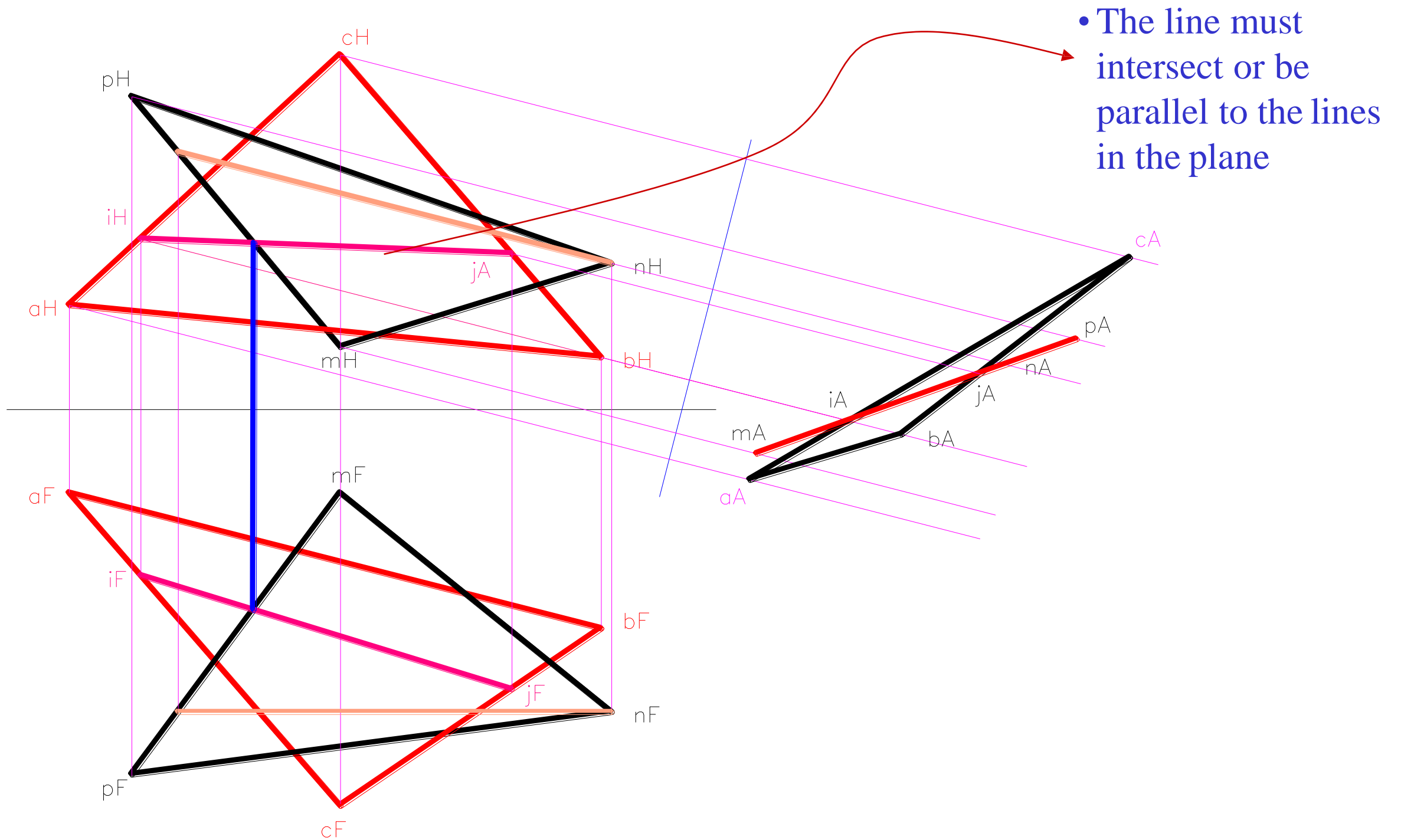

Intersection of two planes – CP Cutting Plane Method

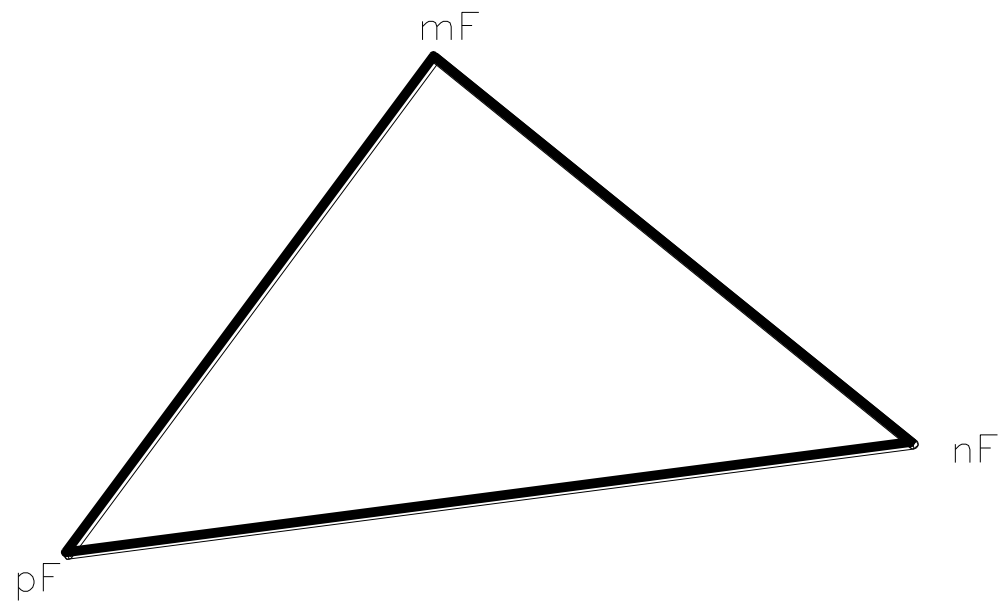
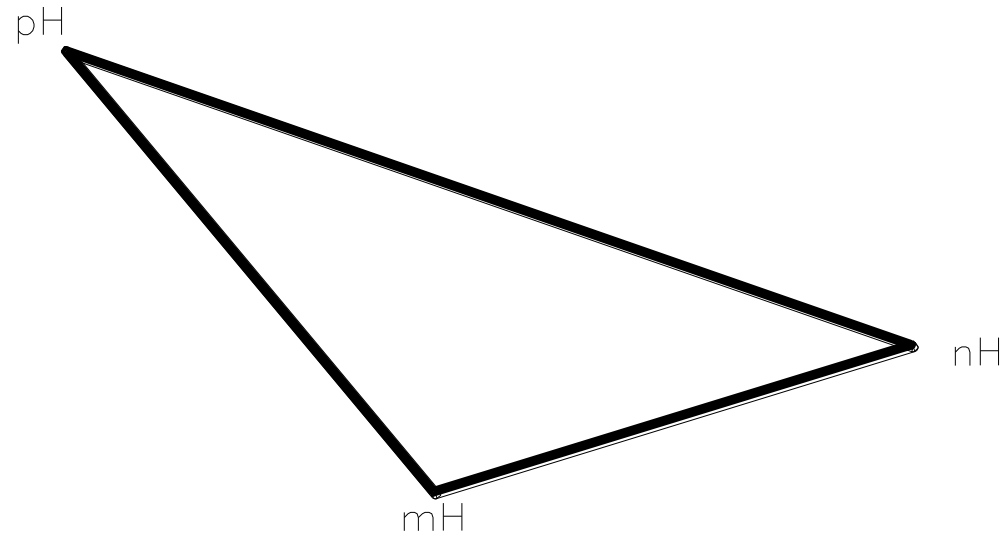

Intersection of two planes – CP Cutting Plane Method

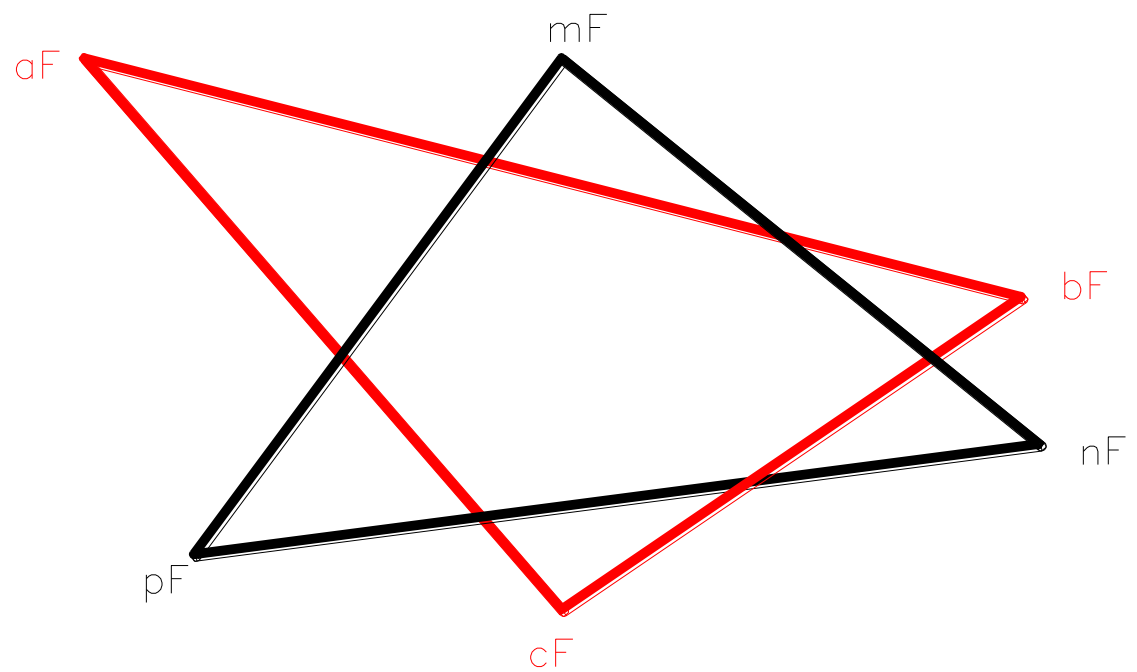
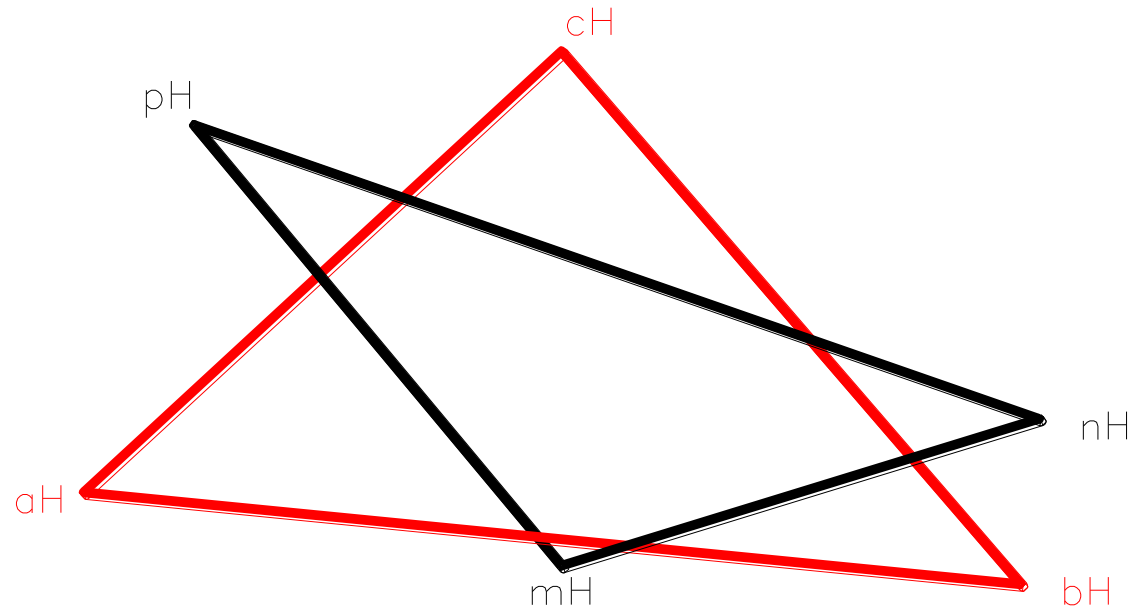

Intersection of two planes – CP Cutting Plane Method

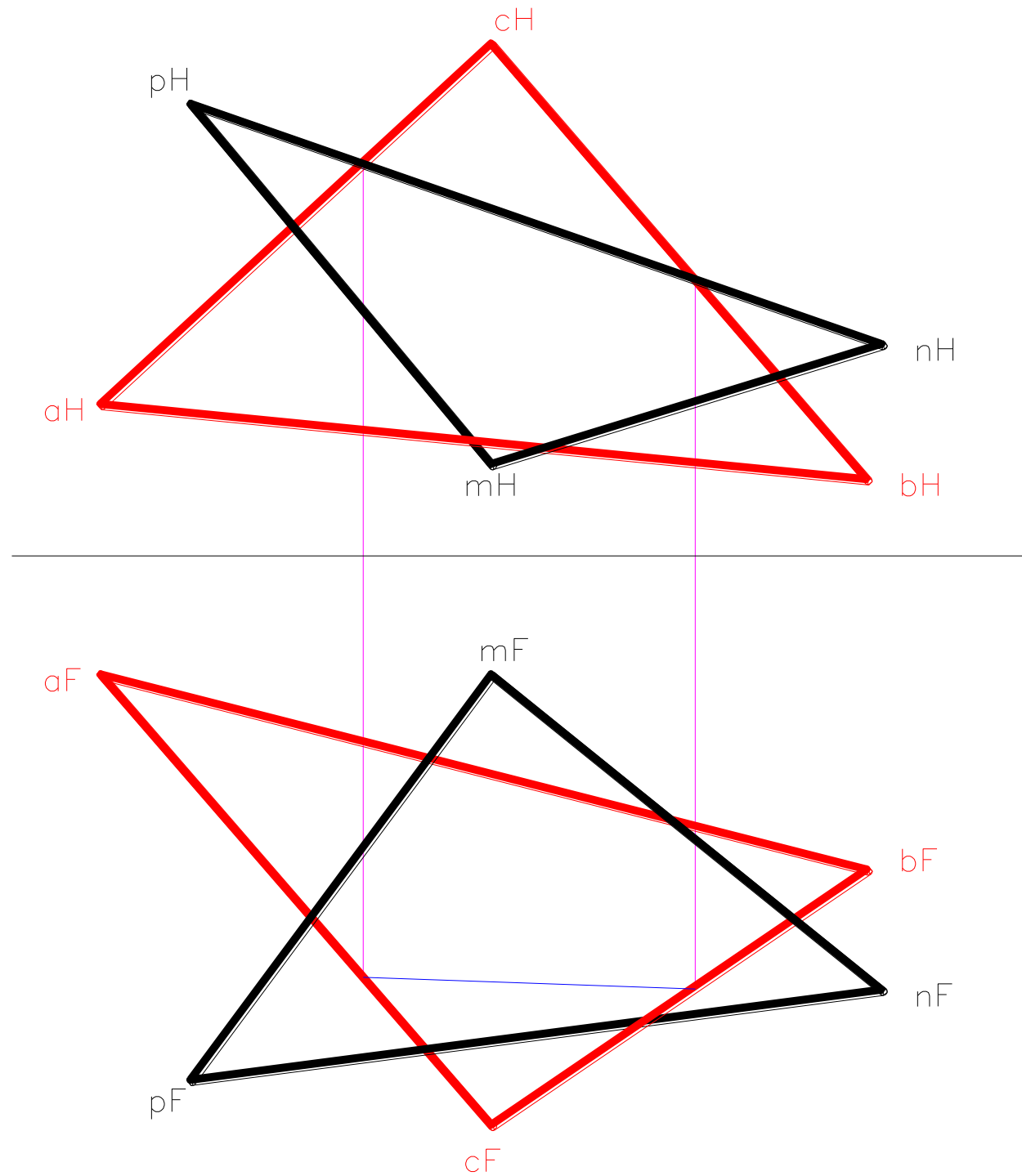

Intersection of two planes – CP Cutting Plane Method

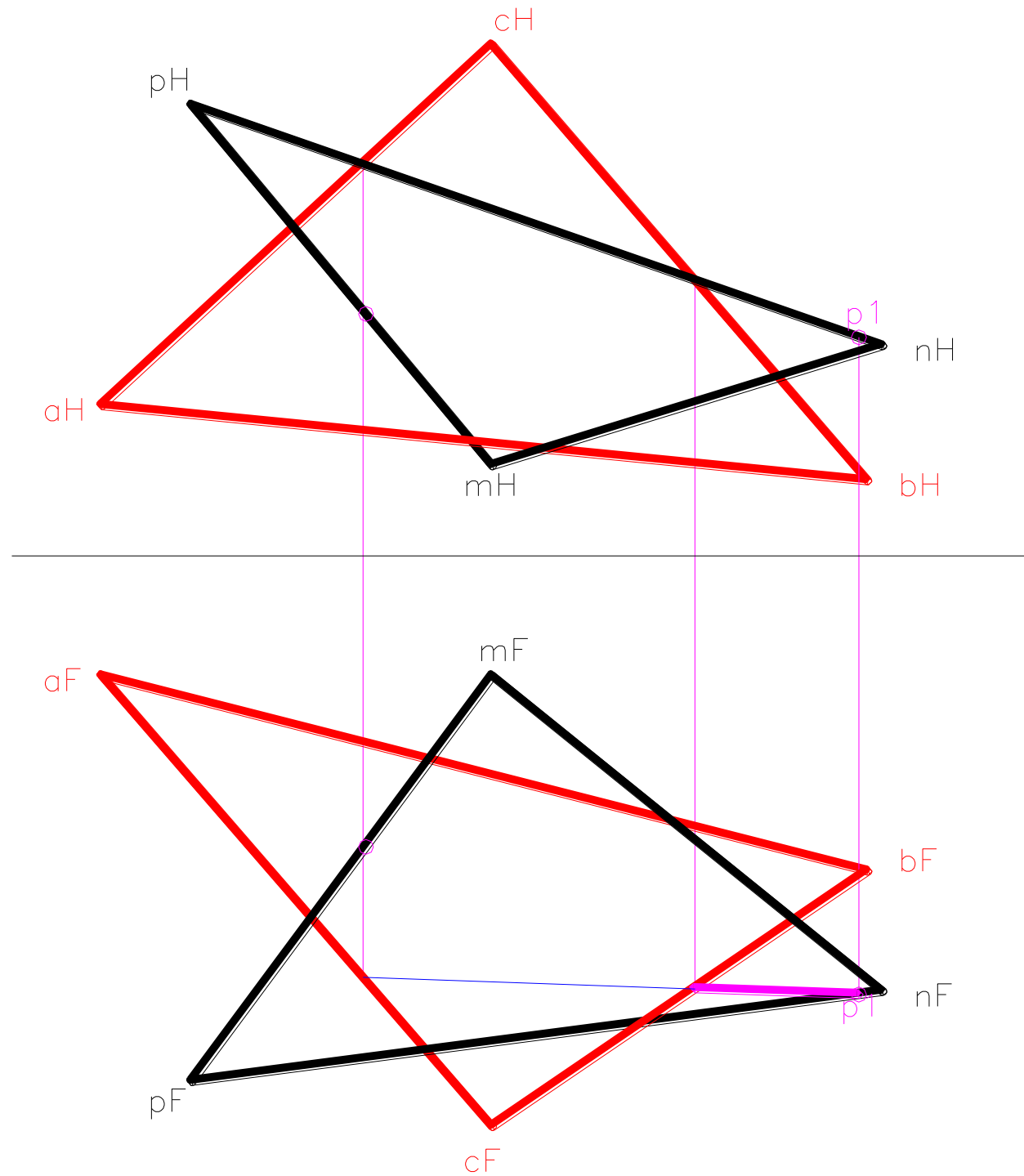

Intersection of two planes – CP Cutting Plane Method

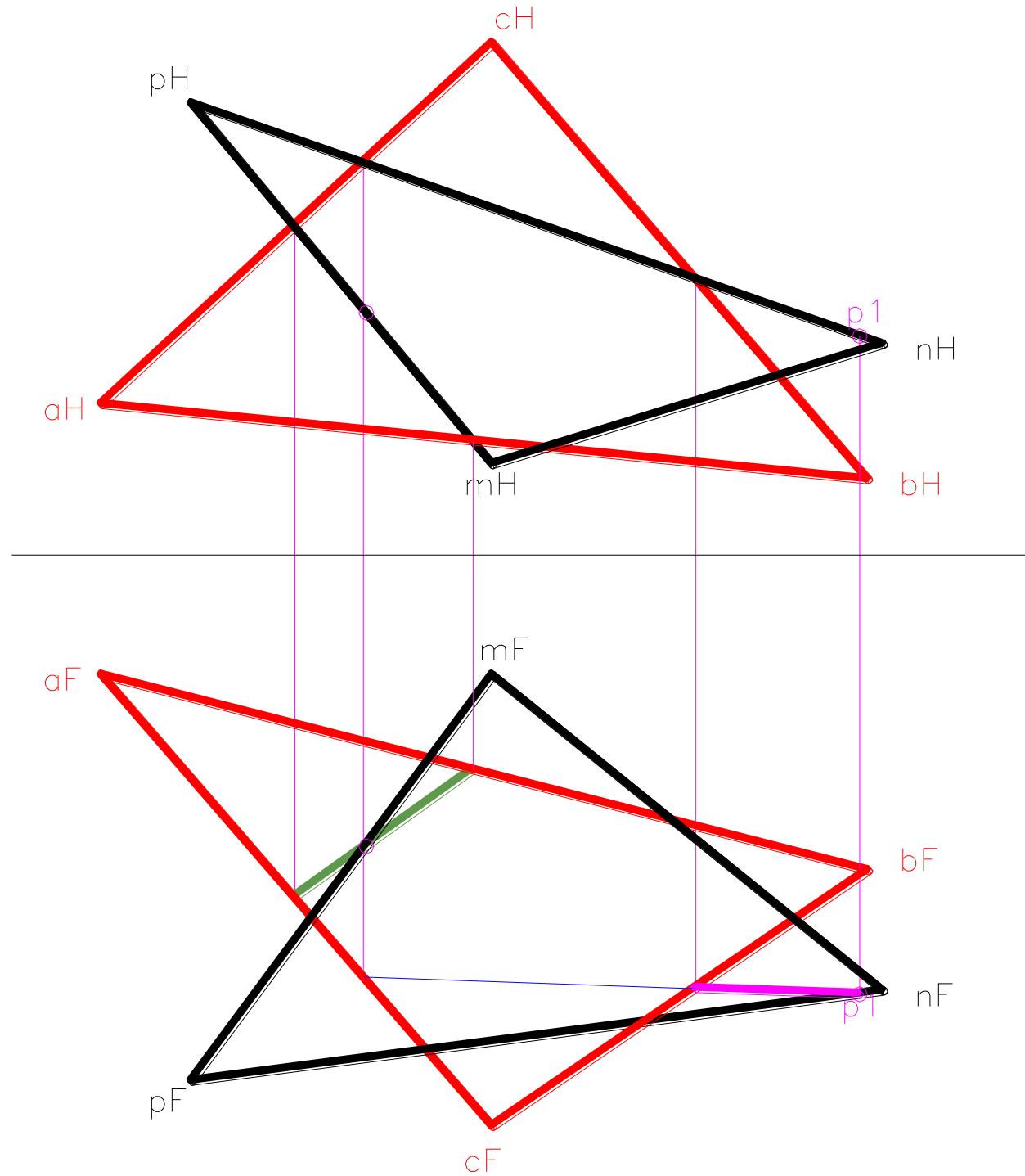

Intersection of two planes – CP Cutting Plane Method

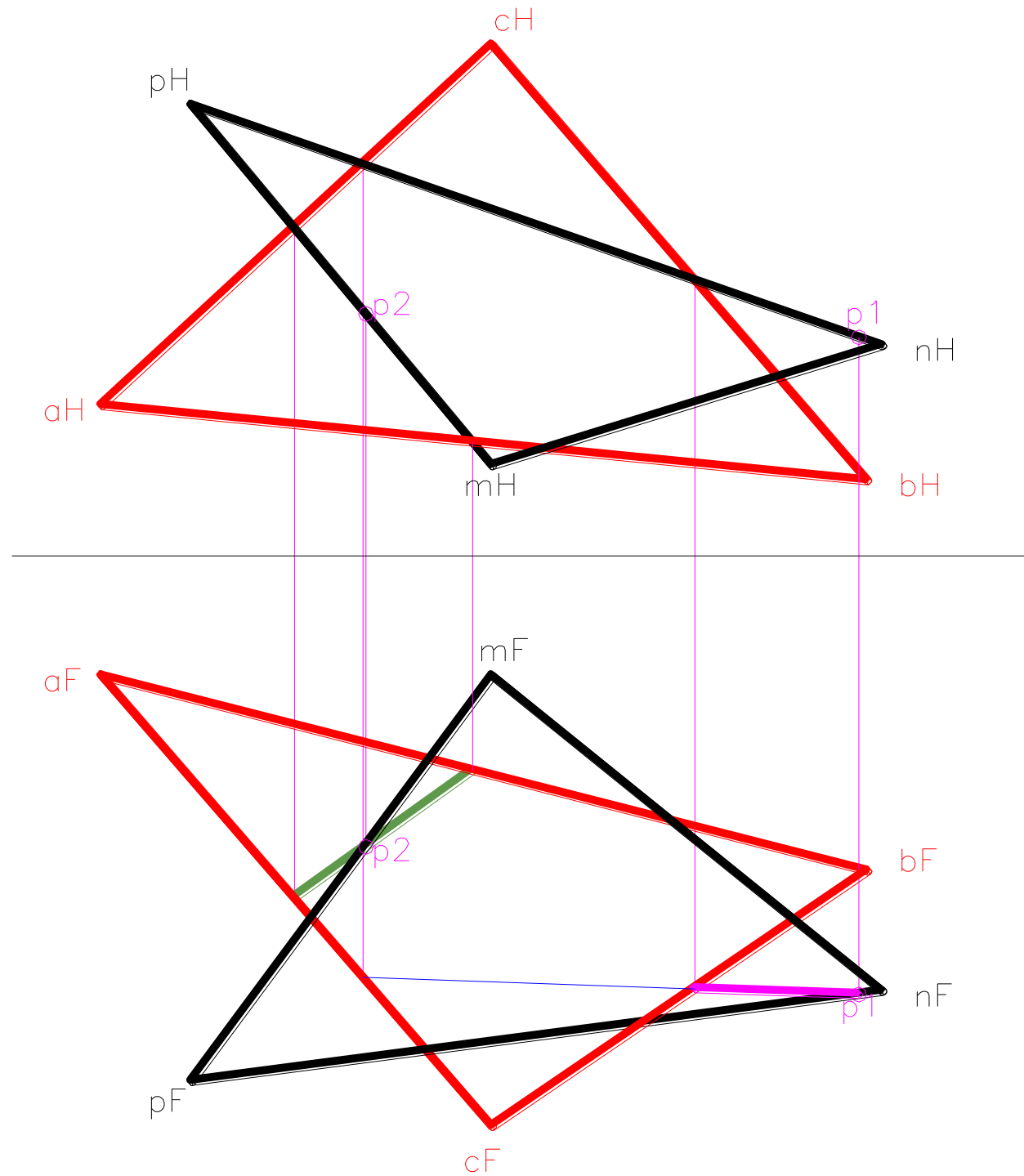

Intersection of two planes – CP Cutting Plane Method

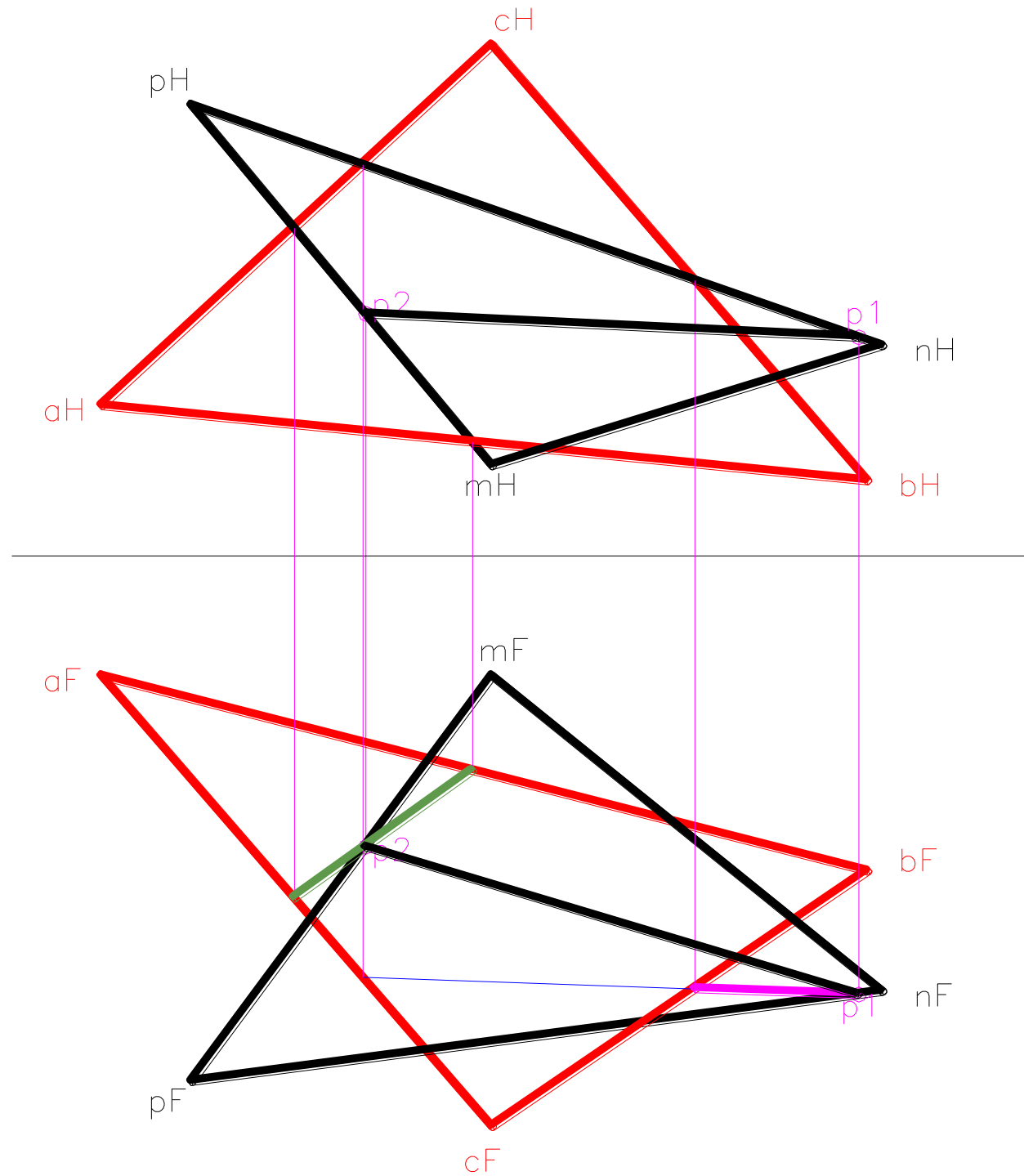

Intersection of two planes - EV

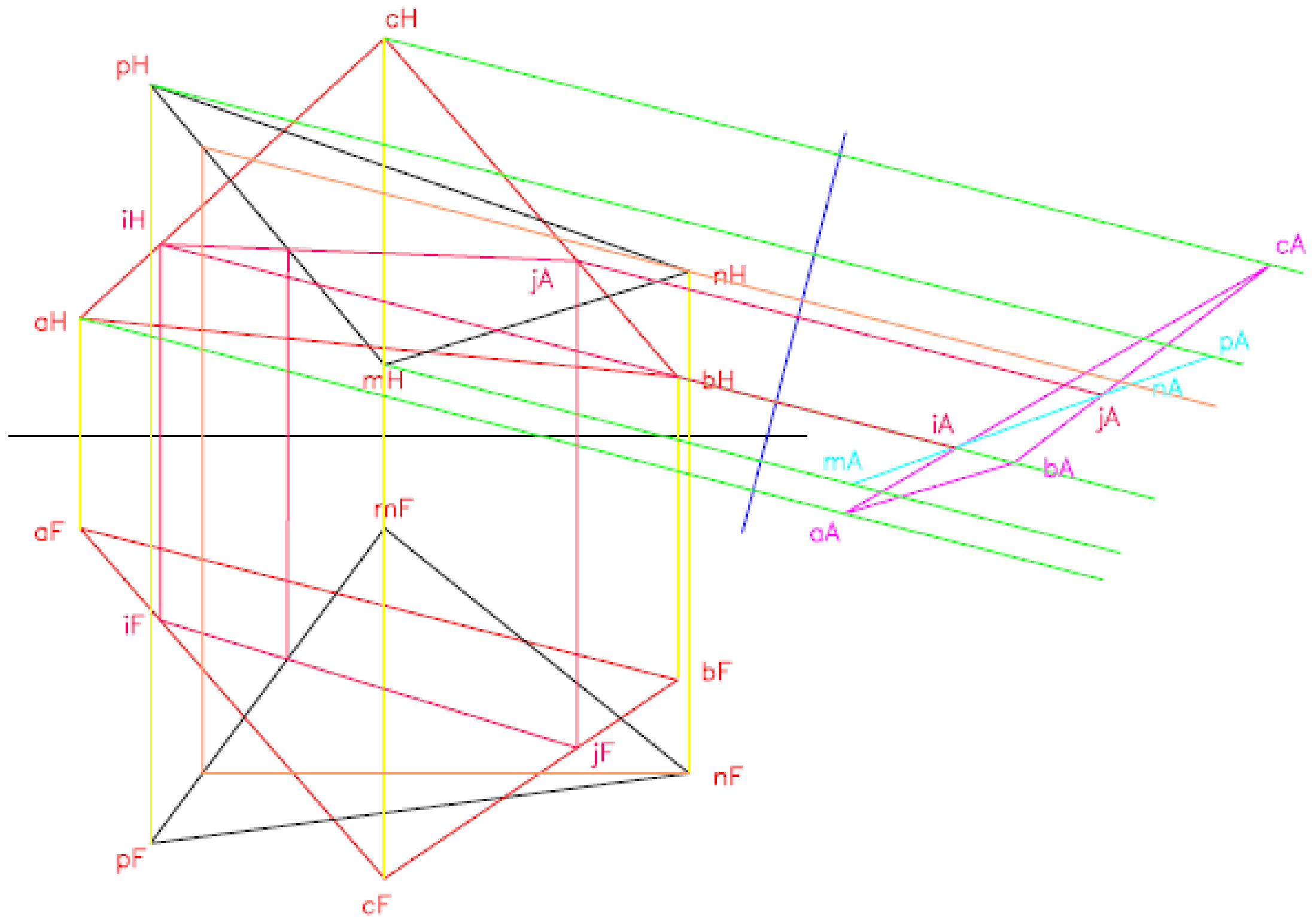

Intersection of two planes - CP

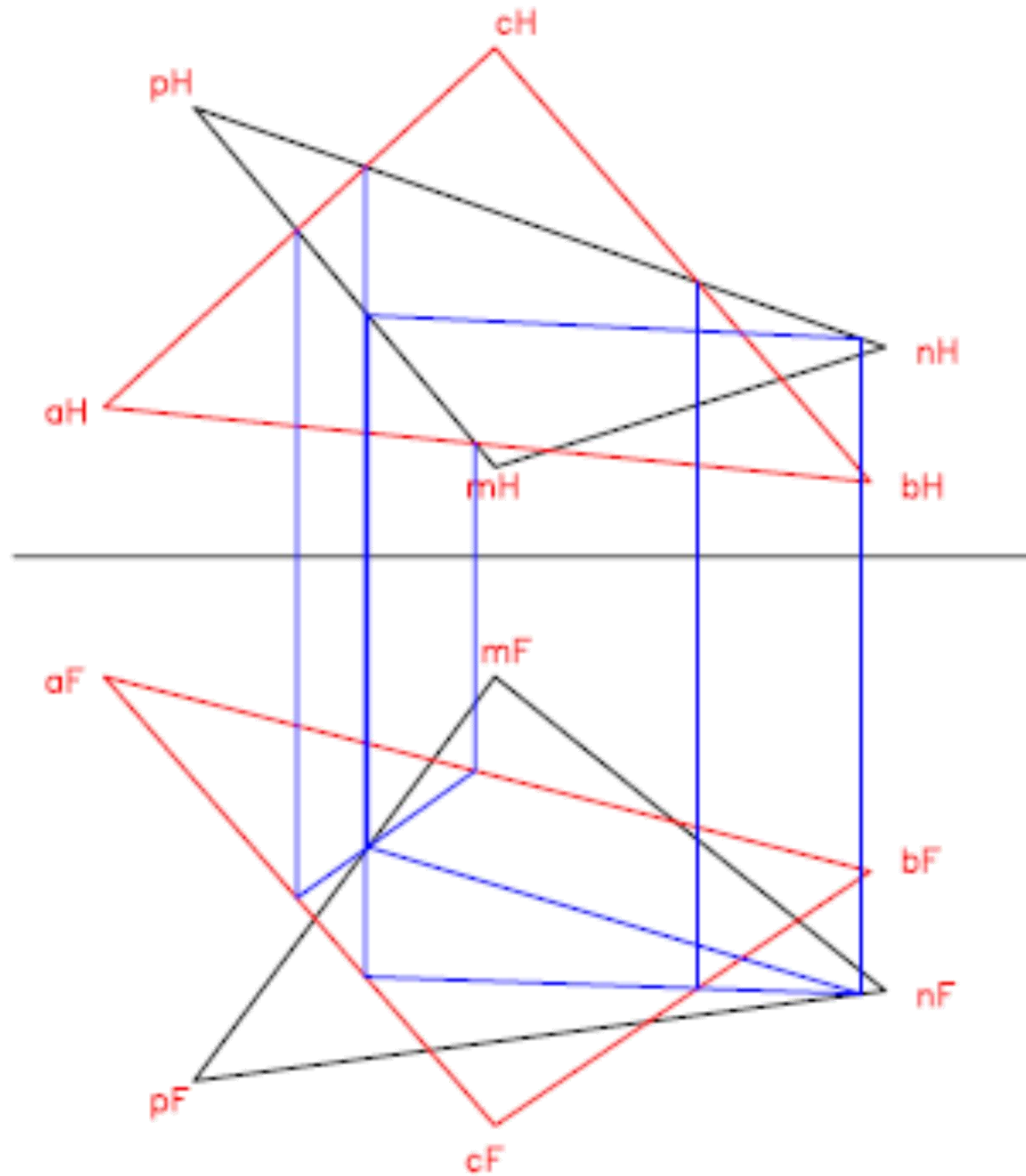

Cutting plane method – intersection of a line with a plane

The rule of visibility

