

MECH 211 – Mechanical Engineering Drawing

François Tardy

Credits: 3.5

Lecture 8

Content of the lecture

- Developments – every line in a development is a TL.
- Revolution method.
- Box, right prism, right pyramid, right cylinder, right cone.
- Development of a right/oblique prism.
- Development of a right/oblique cylinder.
- Development of a right/oblique pyramid.



Content of the lecture

- Triangulation method
- Development of an Oblique cone
- Development of Transition Parts



TL of a Line Revolution Method

Ⓐ REVOLUTION METHOD

,in contrast with the auxiliary view method, requires that the object change its position (rotate about a specified axis) while the observer keep his point of view.

It is convenient to rotate an object about an axis that appears as a point in one view and as a True Length in the other, so that traces of rotated points appear as circular paths about the point view of the axis, and as lines perpendicular to the axis in its True Length view.

If the axis of rotation is oblique, show it as a True Length and a Point View in auxiliary views; rotate the object(s) in these views and trace them to the original views.

TRUE LENGTH OF A LINE BY REVOLTING

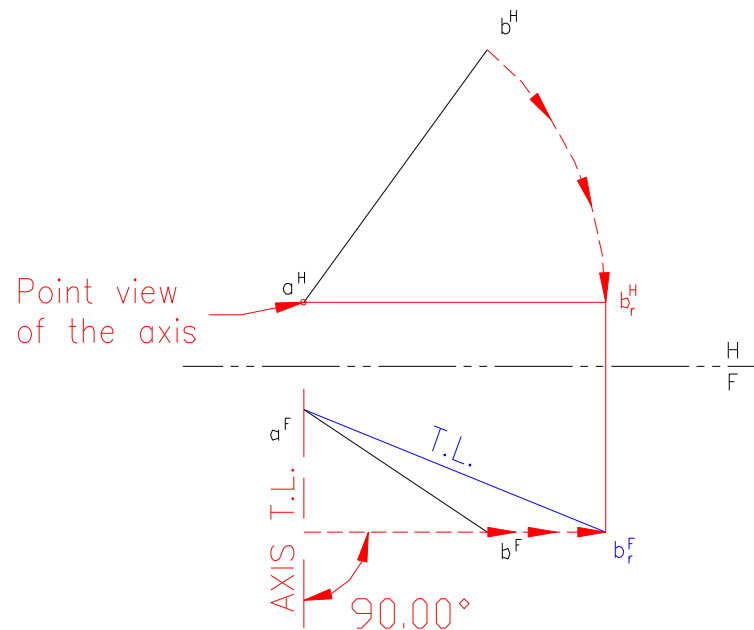

TL of a Line – Revolution Method

(A) REVOLUTION METHOD

TRUE LENGTH OF A LINE BY REVOLVING

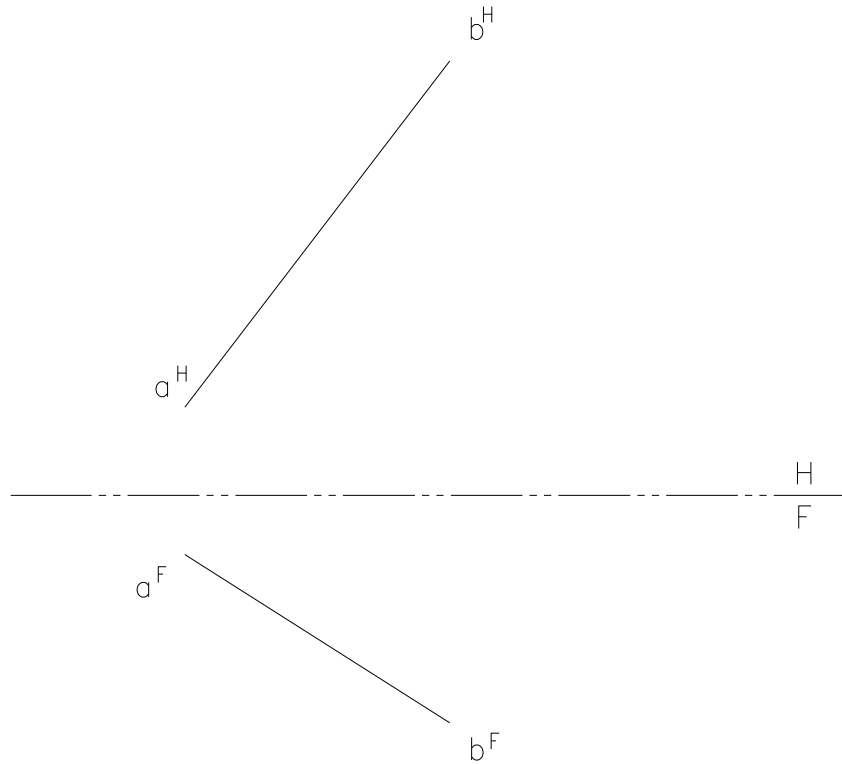

TL of a Line – Revolution Method

(A) REVOLUTION METHOD

TRUE LENGTH OF A LINE BY REVOLVING

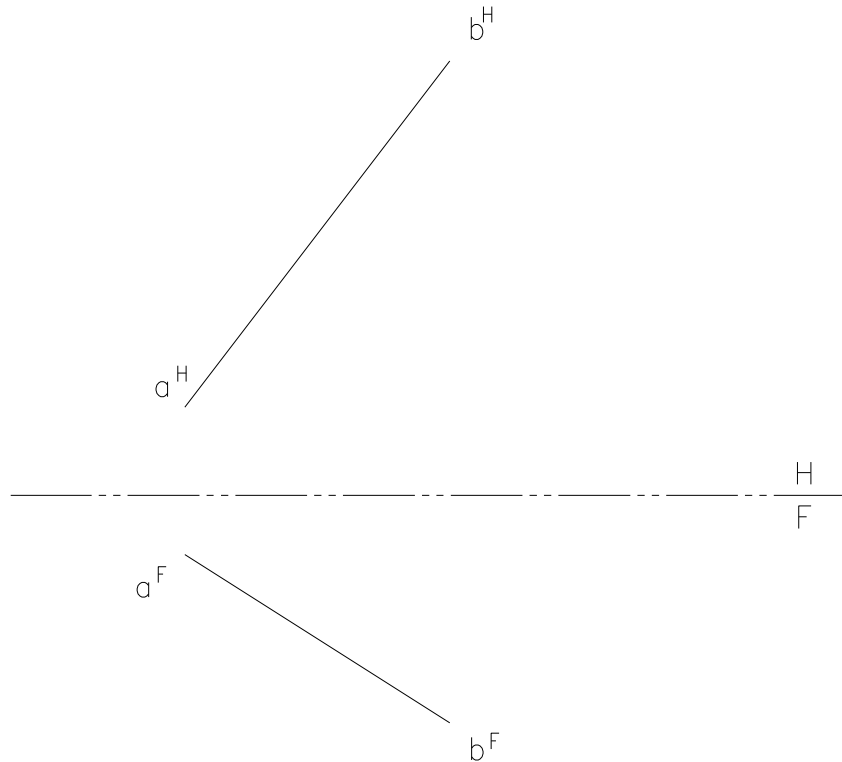

,in contrast with the auxiliary view method, requires that the object change its position (rotate about a specified axis) while the observer keep his point of view.

TL of a Line – Revolution Method

(A) REVOLUTION METHOD

TRUE LENGTH OF A LINE BY REVOLVING

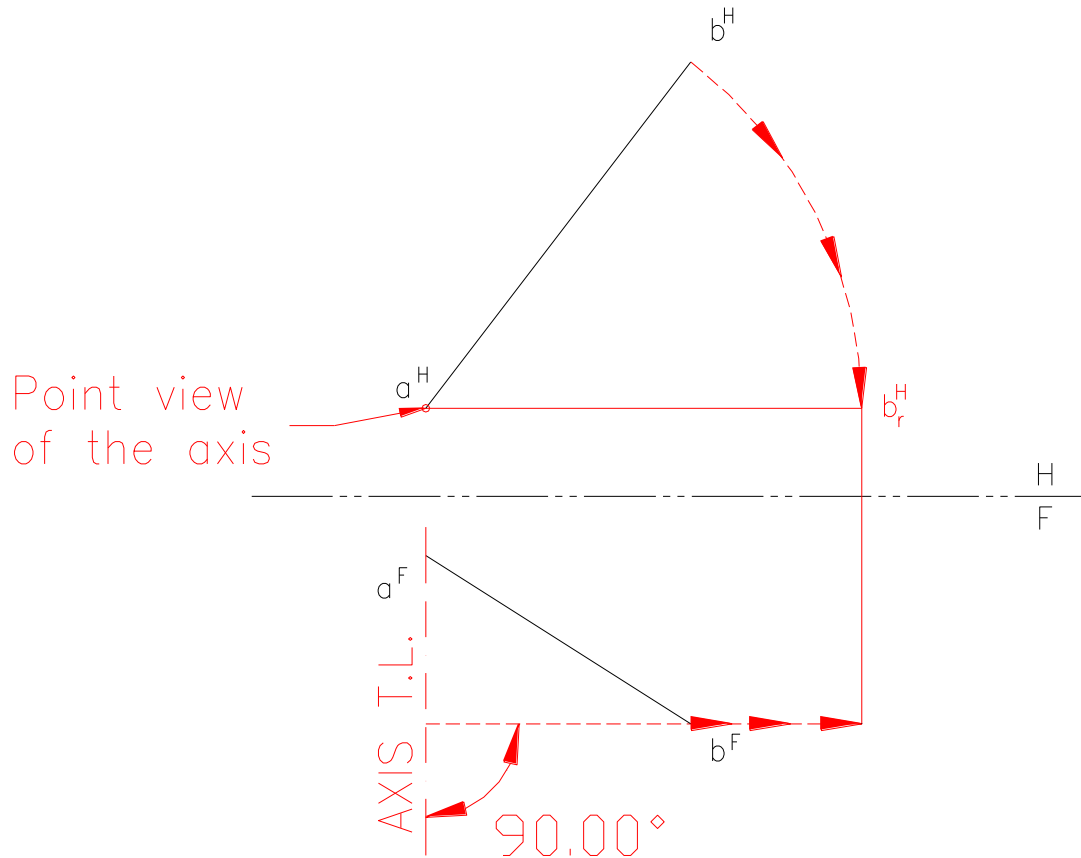

,in contrast with the auxiliary view method, requires that the object change its position (rotate about a specified axis) while the observer keep his point of view.

It is convenient to rotate an object about an axis that appears as a point in one view and as a True Length in the other, so that traces of rotated points appear as circular paths about the point view of the axis, and as lines perpendicular to the axis in its True Length view.

TL of a Line – Revolution Method

(A) REVOLUTION METHOD

TRUE LENGTH OF A LINE BY REVOLVING

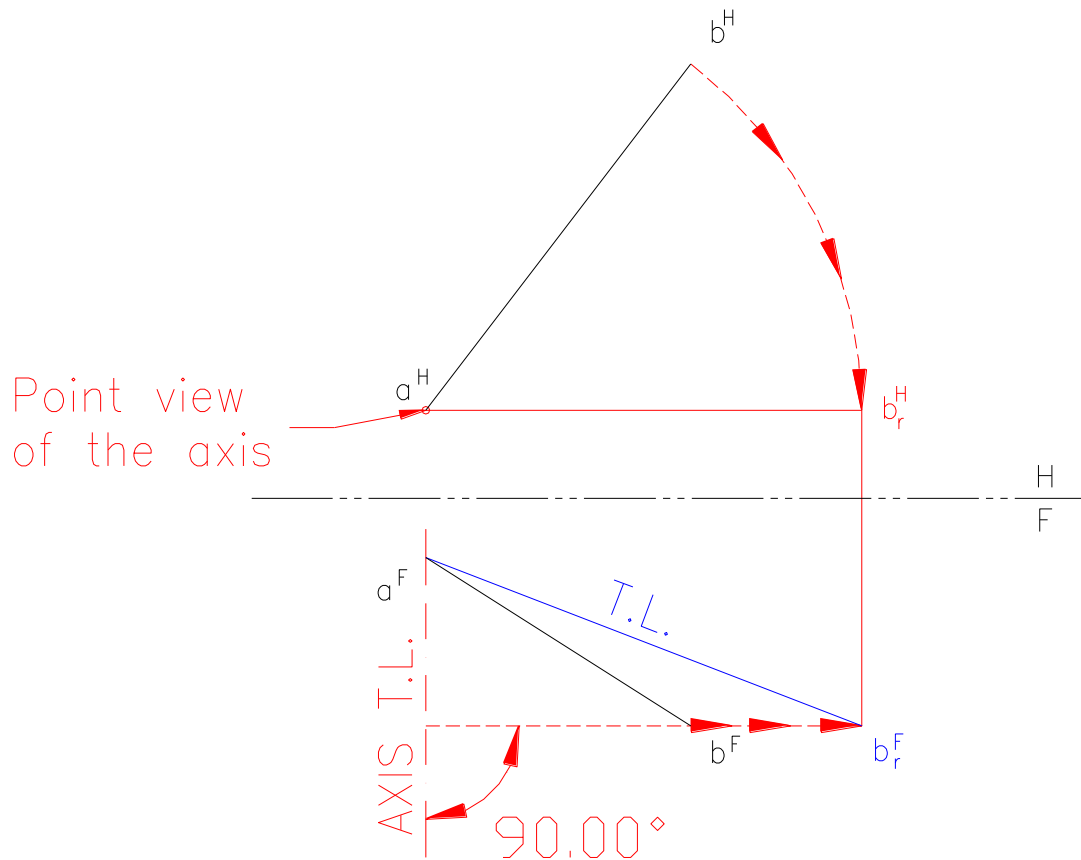

,in contrast with the auxiliary view method, requires that the object change its position (rotate about a specified axis) while the observer keep his point of view.

It is convenient to rotate an object about an axis that appears as a point in one view and as a True Length in the other, so that traces of rotated points appear as circular paths about the point view of the axis, and as lines perpendicular to the axis in its True Length view.

If the axis of rotation is oblique, show it as a True Length and a Point View in auxiliary views; rotate the object(s) in these views and trace them to the original views.

Developments

- A development is the unfolding or unrolling of a 3D surface into a plane surface.
- Single curved and surfaces of polyhedrons can be developed.
- Warped and double curved surfaces can be developed only approximately.
- Several practical applications.
 - Sheet metal
 - Textiles
 - Etc.

Development of box, right prism, right pyramid, right cylinder, right cone

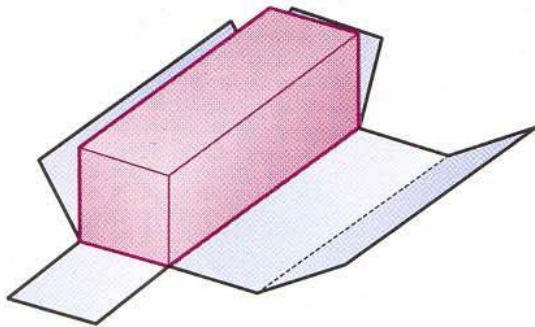

(A) Prism
(Parallel line development)

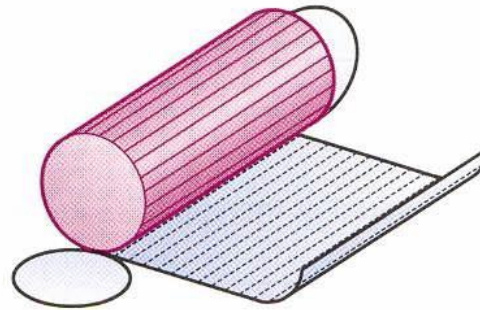

(B) Cylinder
(Parallel line development)

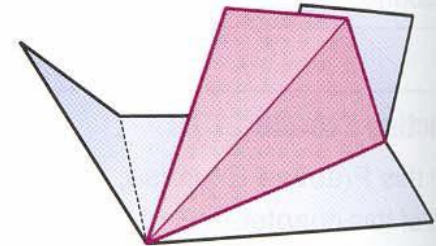

(C) Pyramid
(Radial line development)

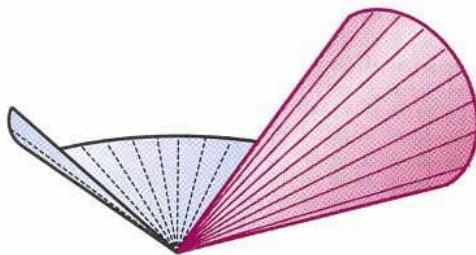

(D) Cone
(Radial line development)

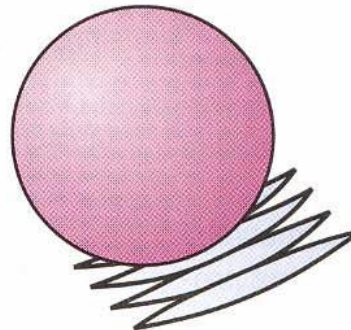

(E) Sphere
(Approximate development)

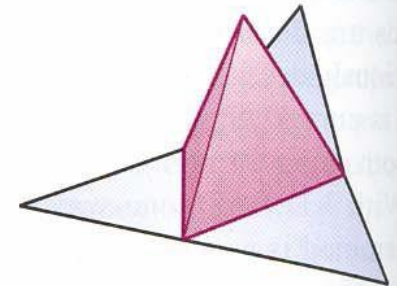

(F) Tetrahedron
(Triangulation development)

Developments

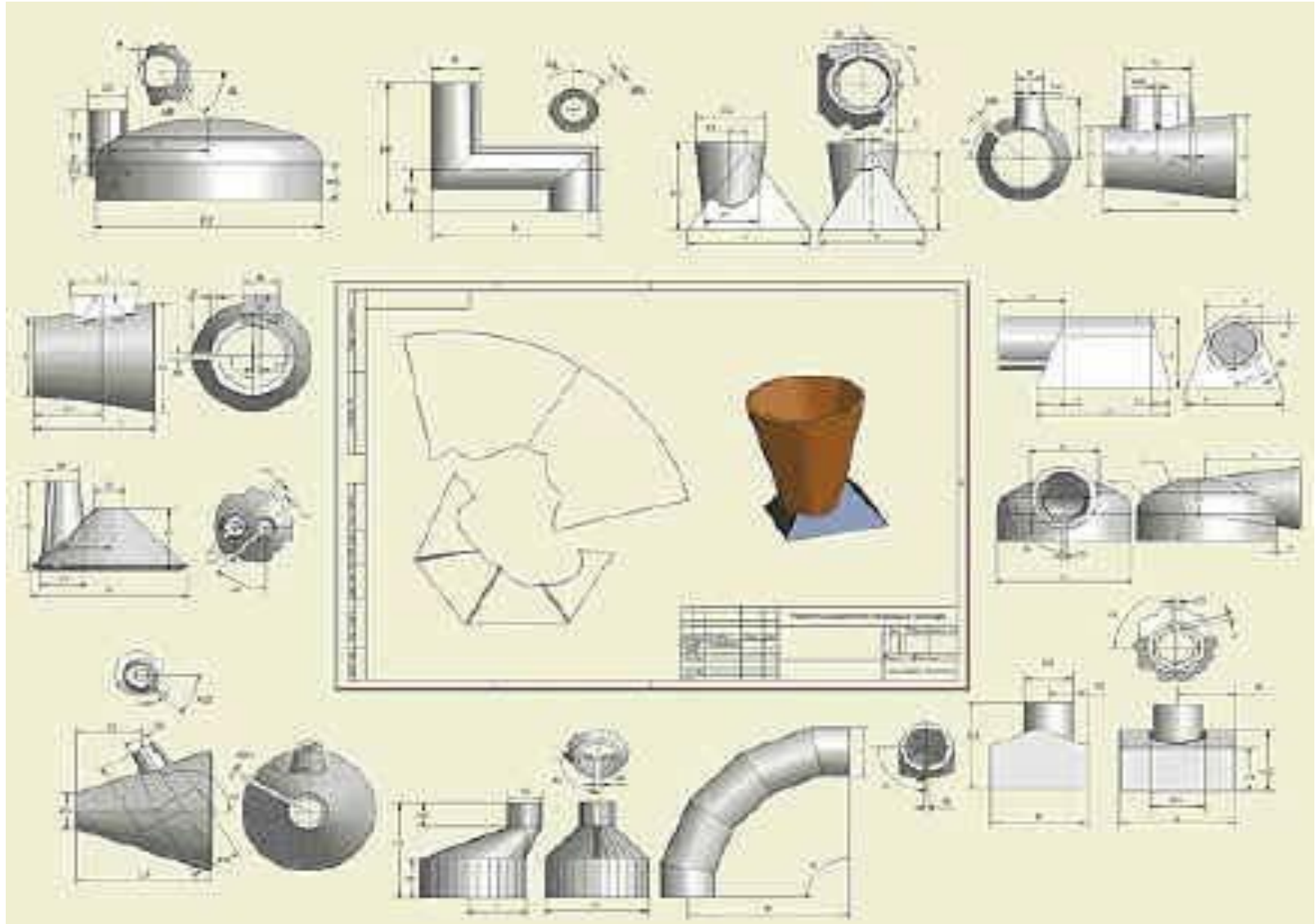

Parallel Line Method

Developments:

- Right Prism
- Oblique Prism
- Right Cylinder
- Oblique Cylinder

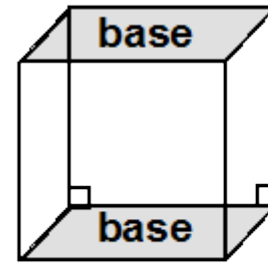

Right prism

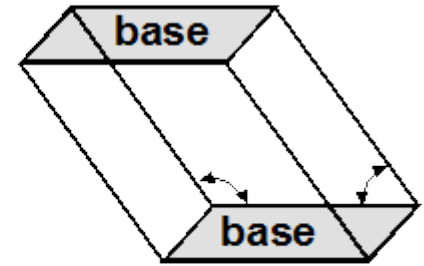

Non-right prism

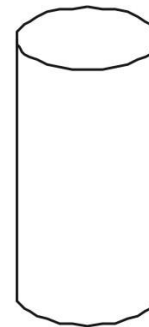

right cylinder

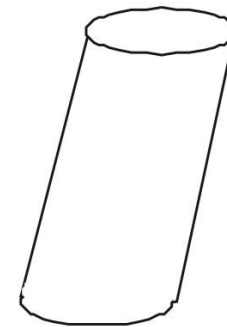

oblique cylinder

Development of a Right Prism

(A) DEVELOPMENTS. RIGHT PRISM.

Every line on a development shows the true length of the corresponding line on the surface.

For economy and simplicity seams should be taken on the shortest line, preferably on a line of symmetry.

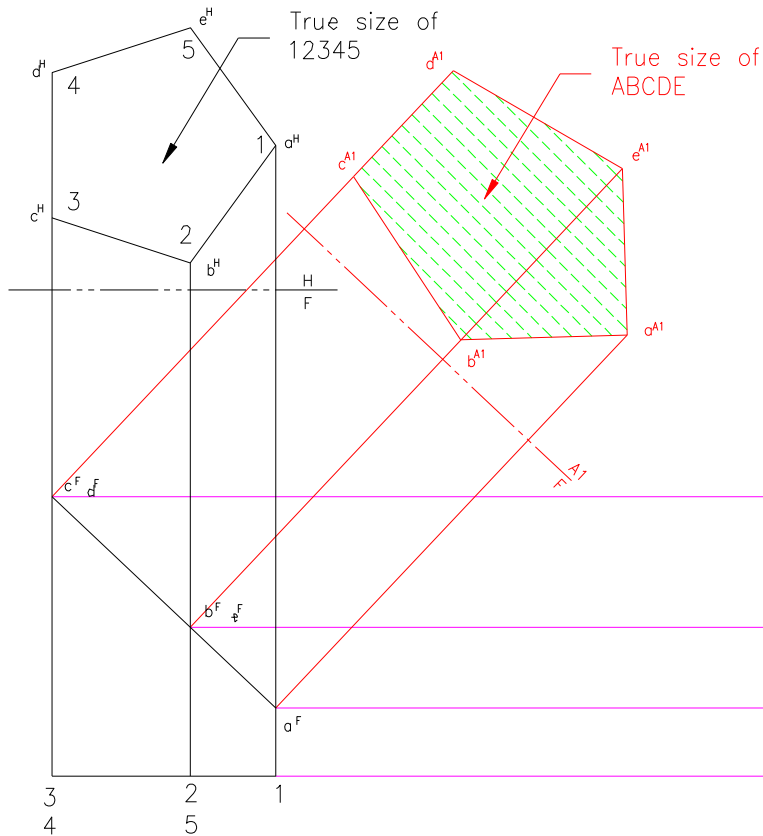

The lateral edges of the prism appear as true-length in the front view;
 Right section of the prism is also given in the top view;
 Thus the given views provide all necessary information for the development:

1. Bases need to be drawn on long matching edges
2. Development is drawn with inside surfaces
3. By this bend lines and other markings relate to inside measurements and all workshop machines are designed to work with markings upward

True size of the upper surface is translated to the development and attached by one of its largest sides.
 Note that surface ABCDE is turned over on the development.

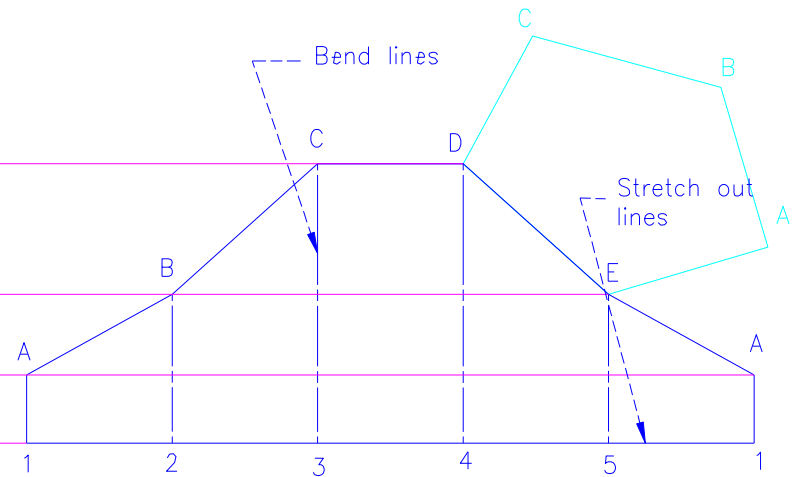

Number	Name	Date	Assignment
L07T01			

Number	Name	Date	Assignment
L07T01			

Development of a Right Prism

(A) DEVELOPMENTS. RIGHT PRISM.

Every line on a development shows the true length of the corresponding line on the surface.

For economy and simplicity seams should be taken on the shortest line, preferably on a line of symmetry.

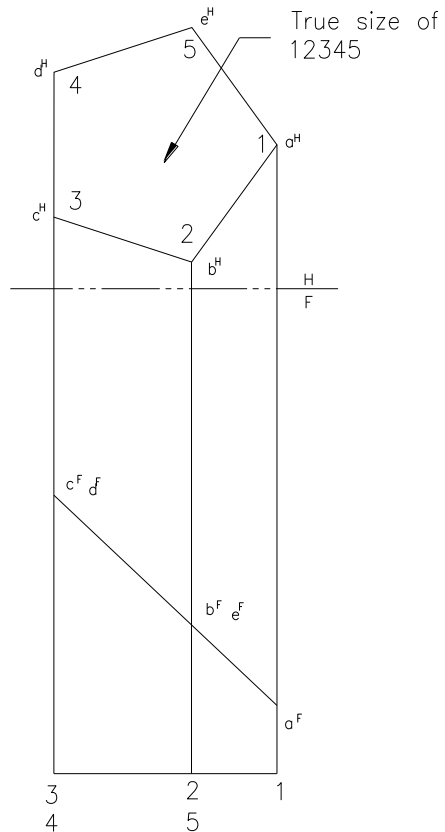

Number	Name	Date	Assignment
L07T01			

Development of a Right Prism

(A) DEVELOPMENTS. RIGHT PRISM.

Every line on a development shows the true length of the corresponding line on the surface.

For economy and simplicity seams should be taken on the shortest line, preferably on a line of symmetry.

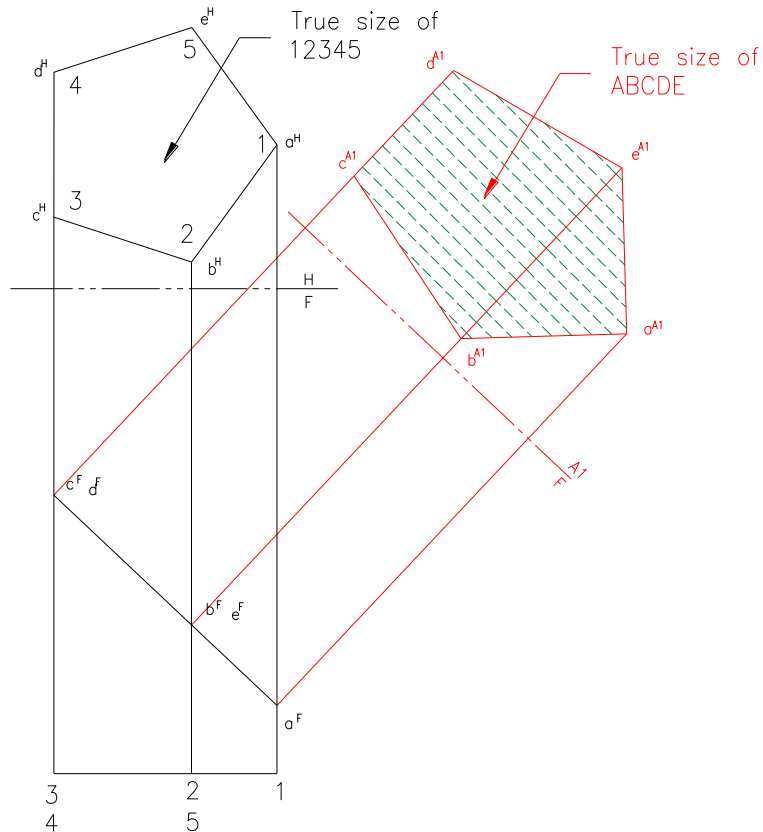

Number	Name	Date	Assignment
L07T01			

Development of a Right Prism

(A) DEVELOPMENTS. RIGHT PRISM.

Every line on a development shows the true length of the corresponding line on the surface.

For economy and simplicity seams should be taken on the shortest line, preferably on a line of symmetry.

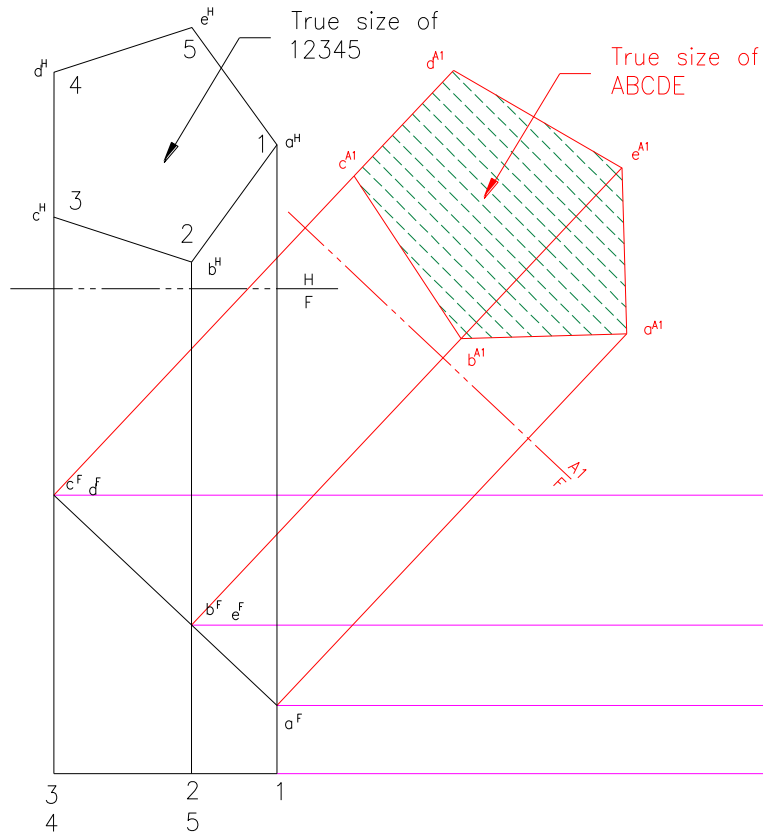

Number	Name	Date	Assignment
L07T01			

Number	Name	Date	Assignment
L07T01			

Development of a Right Prism

(A) DEVELOPMENTS. RIGHT PRISM.

Every line on a development shows the true length of the corresponding line on the surface.

For economy and simplicity seams should be taken on the shortest line, preferably on a line of symmetry.

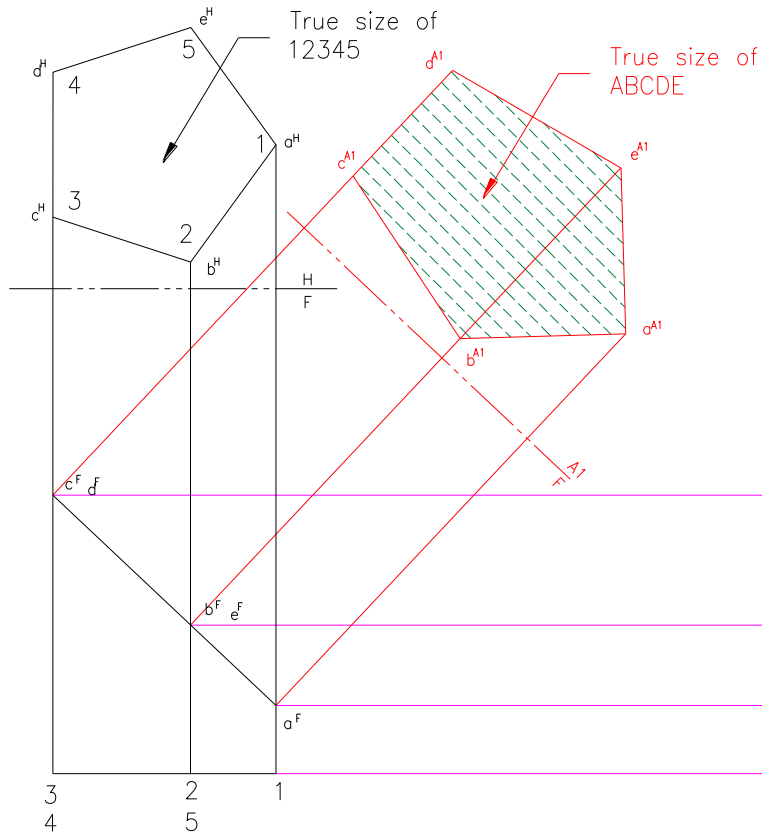

The lateral edges of the prism appear as true-length in the front view;
 Right section of the prism is also given in the top view;
 Thus the given views provide all necessary information for the development:

1. Bases need to be drawn on long matching edges
2. Development is drawn with inside surfaces
3. By this bend lines and other markings relate to inside measurements and all workshop machines are designed to work with markings upward

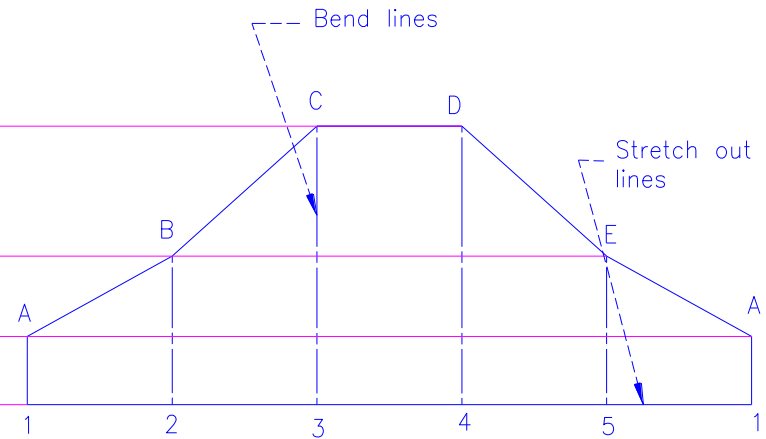

Number	Name	Date	Assignment
L07T01			

Number	Name	Date	Assignment
L07T01			

Development of a Right Prism

(A) DEVELOPMENTS. RIGHT PRISM.

Every line on a development shows the true length of the corresponding line on the surface.

For economy and simplicity seams should be taken on the shortest line, preferably on a line of symmetry.

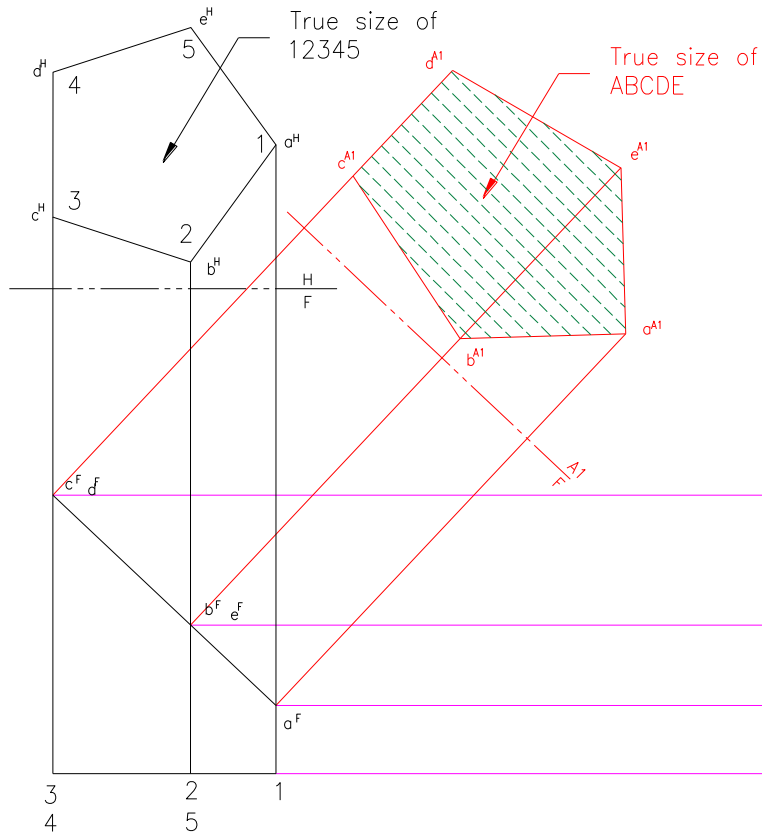

The lateral edges of the prism appear as true-length in the front view;
 Right section of the prism is also given in the top view;
 Thus the given views provide all necessary information for the development:

1. Bases need to be drawn on long matching edges
2. Development is drawn with inside surfaces
3. By this bend lines and other markings relate to inside measurements and all workshop machines are designed to work with markings upward

True size of the upper surface is translated to the development and attached by one of its largest sides. Note that surface ABCDE is turned over on the development.

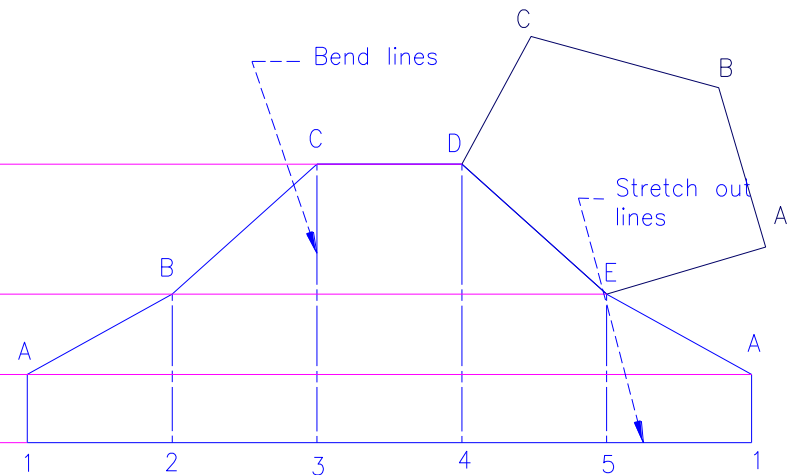

Number	Name	Date	Assignment
L07T01			

Number	Name	Date	Assignment
L07T01			

Development of an Oblique prism

(A) DEVELOPMENTS. OBLIQUE PRISM.

Every line on a development shows the true length of the corresponding line on the surface.

For economy and simplicity seams should be taken on the shortest line, preferably on a line of symmetry.

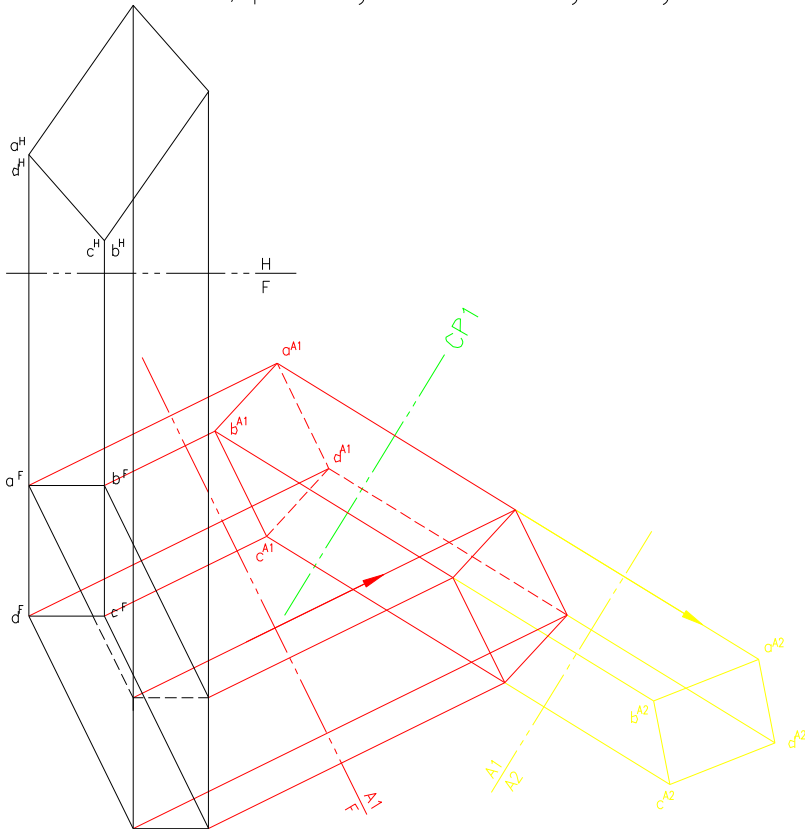

- For the development of an oblique prism we need:
1. A view showing the true length of the lateral edges.
 2. A view showing the lateral edges as points.

Since neither base is perpendicular to the edges, a right section CP1 was constructed.

OBLIQUE PRISM DEVELOPMENT

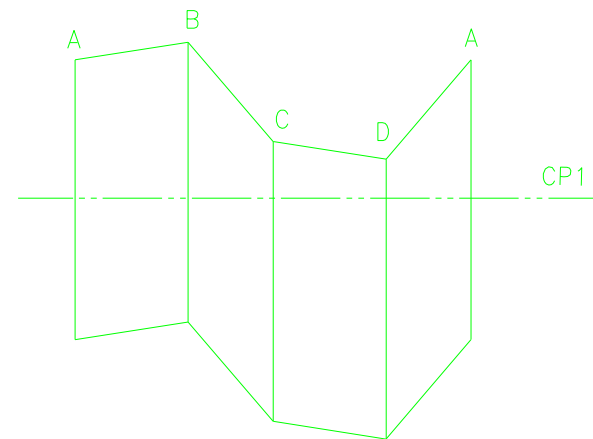

Number	Name	Date	Assignment
L07T02			

Number	Name	Date	Assignment
L07T02			

Development of an Oblique prism

(A) DEVELOPMENTS. OBLIQUE PRISM.

Every line on a development shows the true length of the corresponding line on the surface.

For economy and simplicity seams should be taken on the shortest line, preferably on a line of symmetry.

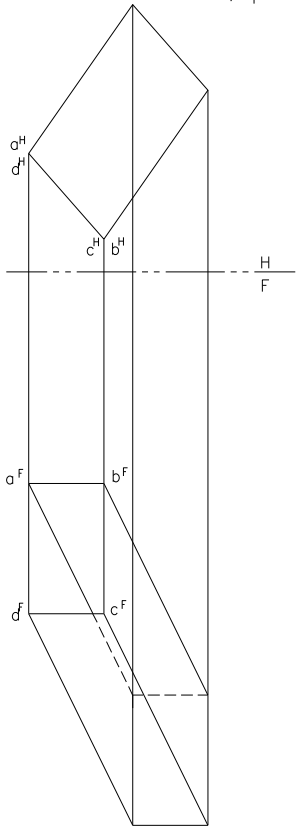

Number
L07T02

Name

Date

Assignment

Development of an Oblique prism

(A) DEVELOPMENTS. OBLIQUE PRISM.

Every line on a development shows the true length of the corresponding line on the surface.

For economy and simplicity seams should be taken on the shortest line, preferably on a line of symmetry.

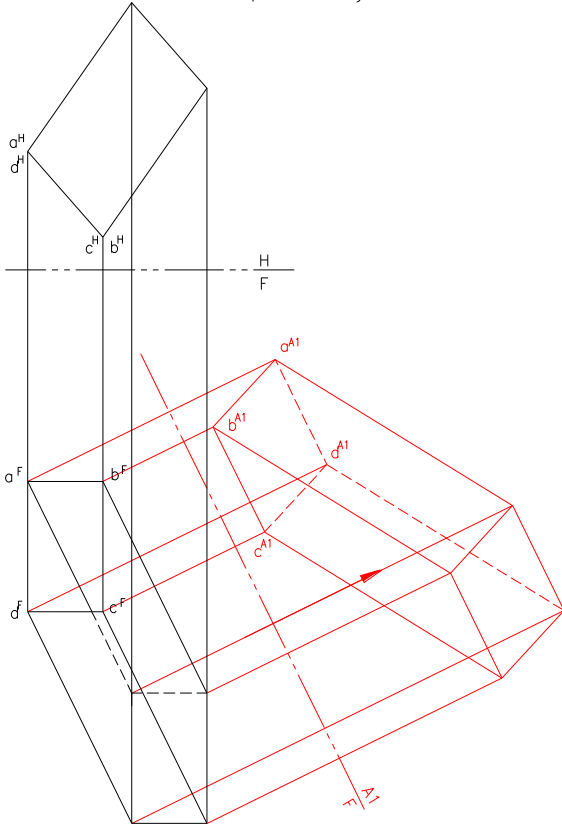

For the development of an oblique prism we need:

1. A view showing the true length of the lateral edges.
2. A view showing the lateral edges as points.

Number
L07T02

Name

Date

Assignment

Number
L07T02

Name

Date

Assignment

Development of an Oblique prism

(A) DEVELOPMENTS. OBLIQUE PRISM.

Every line on a development shows the true length of the corresponding line on the surface.

For economy and simplicity seams should be taken on the shortest line, preferably on a line of symmetry.

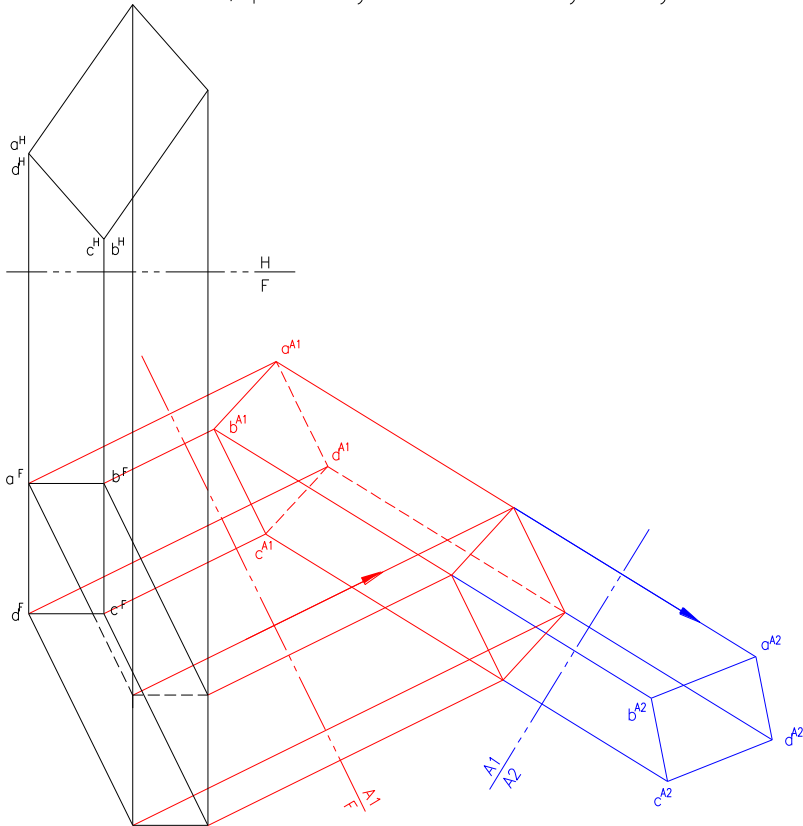

For the development of an oblique prism we need:

1. A view showing the true length of the lateral edges.
2. A view showing the lateral edges as points.

When the lateral edges are seen as points, the TS of the surface $abcd$ is seen that view

Number	Name	Date	Assignment
L07T02			

Number	Name	Date	Assignment
L07T02			

Development of an Oblique prism

(A) DEVELOPMENTS. OBLIQUE PRISM.

Every line on a development shows the true length of the corresponding line on the surface.

For economy and simplicity seams should be taken on the shortest line, preferably on a line of symmetry.

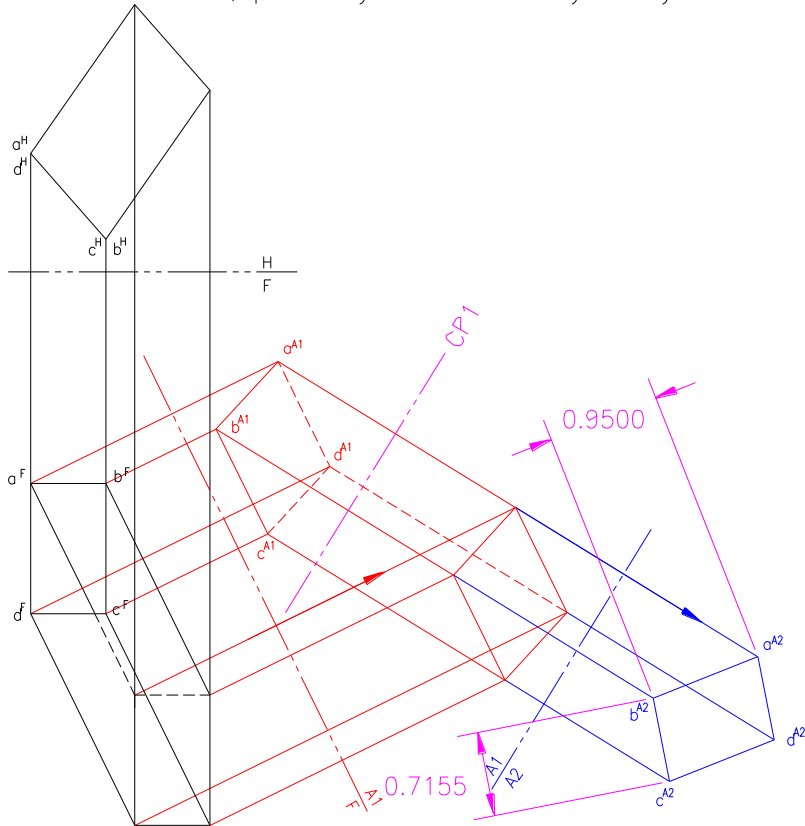

For the development of an oblique prism we need:

1. A view showing the true length of the lateral edges.
2. A view showing the lateral edges as points.

When the lateral edges are seen as points, the TS of the surface $abcd$ is seen that view

Since neither base is perpendicular to the edges, a right section CP1 was constructed. Perpendiculars are erected at distances based on the TS view of the plane $abcd$

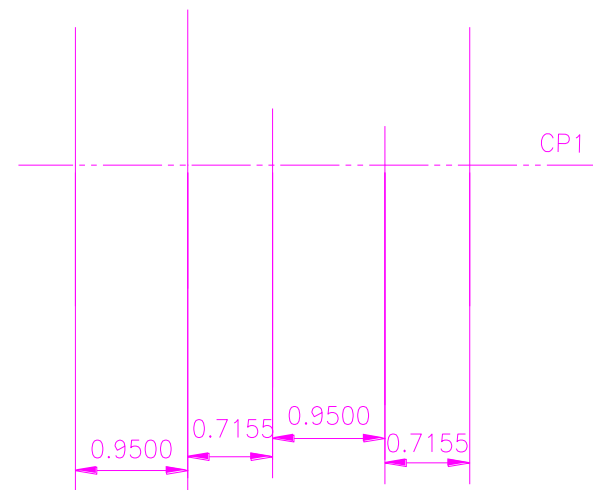

OBLIQUE PRISM DEVELOPMENT

Number	Name	Date	Assignment
L07T02			

Number	Name	Date	Assignment
L07T02			

Development of an Oblique prism

(A) DEVELOPMENTS. OBLIQUE PRISM.

Every line on a development shows the true length of the corresponding line on the surface.

For economy and simplicity seams should be taken on the shortest line, preferably on a line of symmetry.

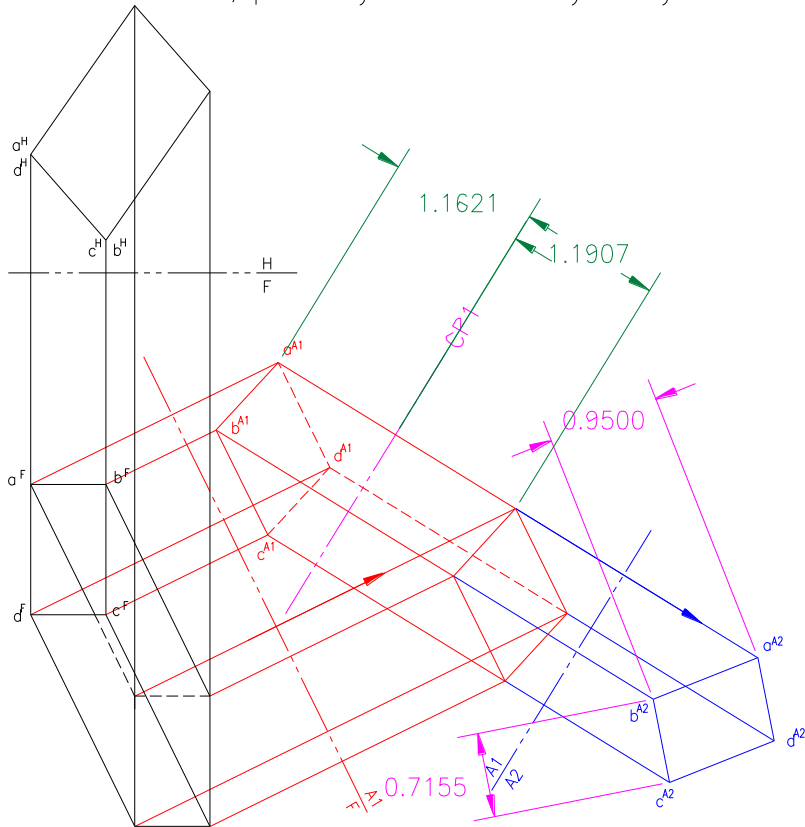

For the development of an oblique prism we need:

1. A view showing the true length of the lateral edges.
2. A view showing the lateral edges as points.

When the lateral edges are seen as points, the TS of the surface abcd is seen that view

Since neither base is perpendicular to the edges, a right section CP1 was constructed. Perpendiculars are erected at distances based on the TS view of the plane abcd

Distances of points abcde and corresponding points on the other side of the prism from the CP are taken and marked on the development to complete it.

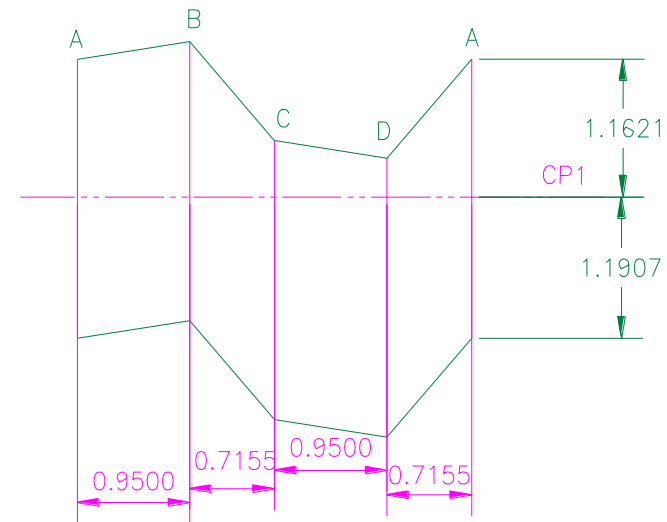

OBLIQUE PRISM DEVELOPMENT

Number	Name	Date	Assignment
L07T02			

Number	Name	Date	Assignment
L07T02			

Development of a Right Circular Cylinder

(A) DEVELOPMENTS. RIGHT CIRCULAR CYLINDER.

Every line on a development shows the true length of the corresponding line on the surface.

For economy and simplicity seams should be taken on the shortest line, preferably on a line of symmetry.

Assume chord to be equal to arc.

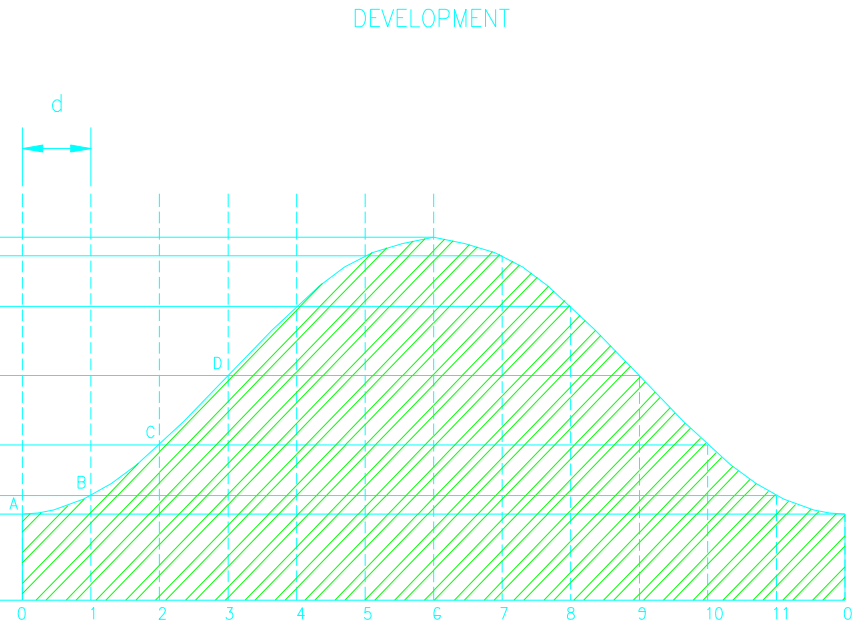
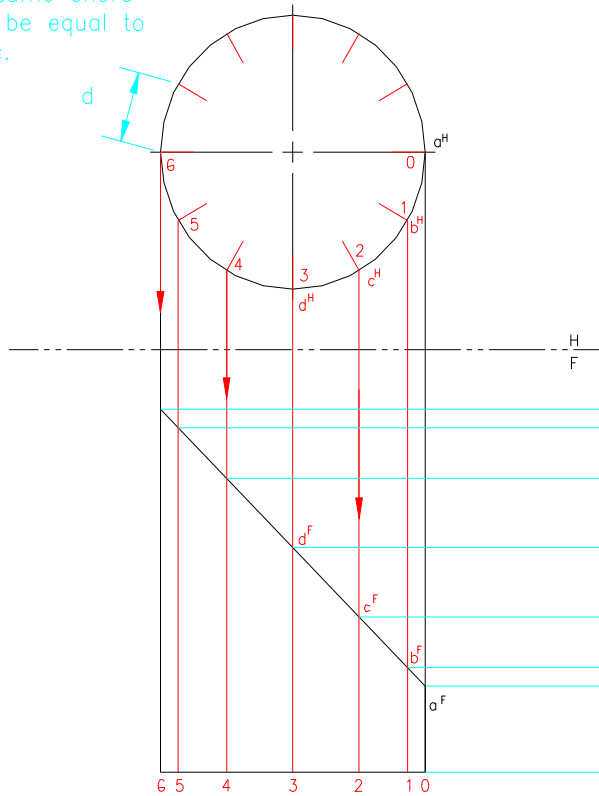

DEVELOPMENT

Number	Name	Date	Assignment
L07T04			

Development of a Right Cylinder

(A) DEVELOPMENTS. RIGHT CIRCULAR CYLINDER.

Every line on a development shows the true length of the corresponding line on the surface.

For economy and simplicity seams should be taken on the shortest line, preferably on a line of symmetry.

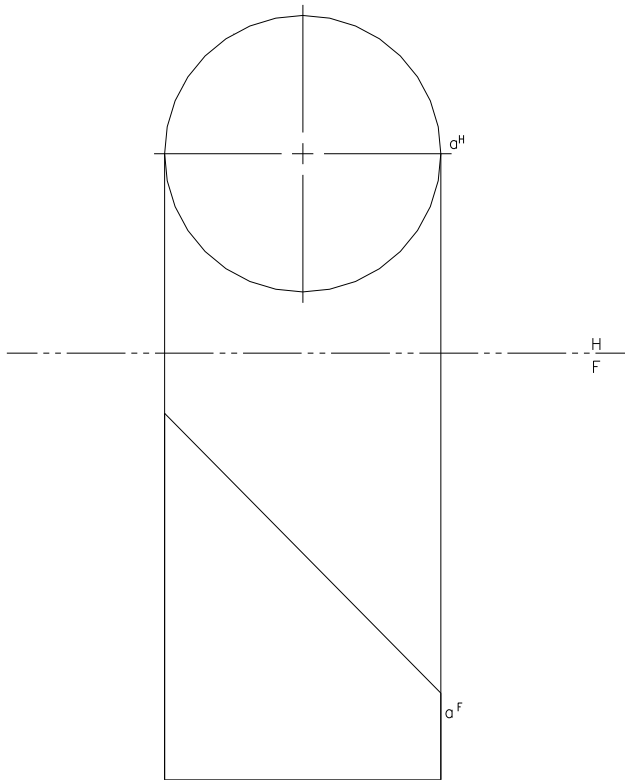

A truncated cylinder is shown, and we use parallel line method to develop this right cylinder

Development of a Right Cylinder

(A) DEVELOPMENTS. RIGHT CIRCULAR CYLINDER.

Every line on a development shows the true length of the corresponding line on the surface.

For economy and simplicity seams should be taken on the shortest line, preferably on a line of symmetry.

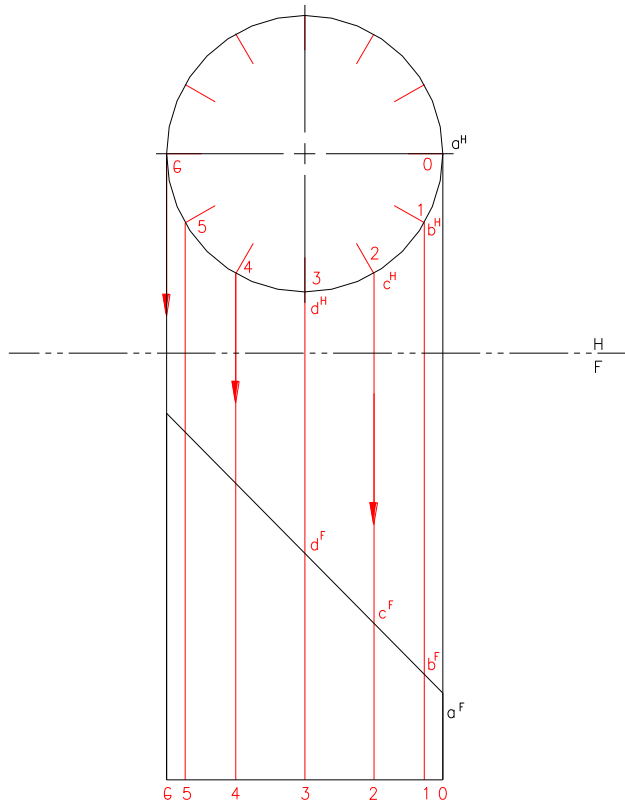

A truncated cylinder is shown, and we use parallel line method to develop this right cylinder

Appropriate number of equally spaced elements is introduced in the TV
The lines are projected from the points in TV to the Front View, where they appear in TL

Development of a Right Cylinder

(A) DEVELOPMENTS. RIGHT CIRCULAR CYLINDER.

Every line on a development shows the true length of the corresponding line on the surface.

For economy and simplicity seams should be taken on the shortest line, preferably on a line of symmetry.

Assume chord to be equal to arc.

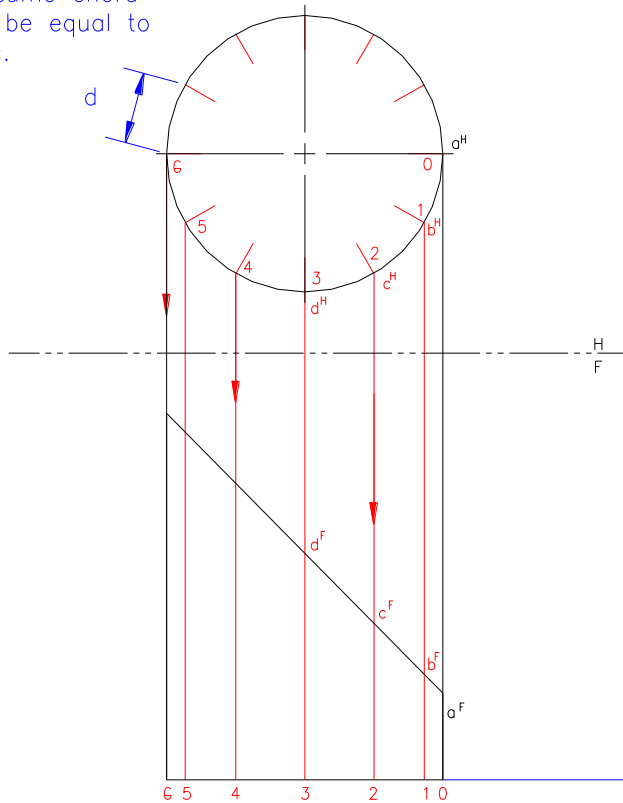

A truncated cylinder is shown, and we use parallel line method to develop this right cylinder

Appropriate number of equally spaced elements is introduced in the TV

The lines are projected from the points in TV to the Front View, where they appear in TL

Length of the stretch out line OO is circumference of the base circle. it is divided into equal number of points as in TV

0 1 2 3 4 5 6 7 8 9 10 11 0

Development of a Right Cylinder

(A) DEVELOPMENTS. RIGHT CIRCULAR CYLINDER.

Every line on a development shows the true length of the corresponding line on the surface.

For economy and simplicity seams should be taken on the shortest line, preferably on a line of symmetry.

Assume chord to be equal to arc.

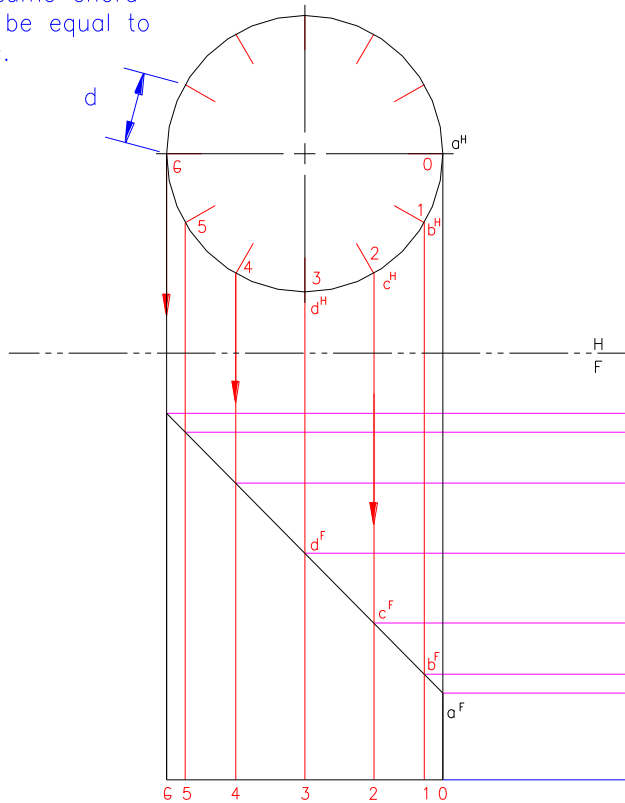

A truncated cylinder is shown, and we use parallel line method to develop this right cylinder

Appropriate number of equally spaced elements is introduced in the TV

The lines are projected from the points in TV to the Front View, where they appear in TL

Length of the stretch out line OO is circumference of the base circle. it is divided into equal number of points as in TV

Perpendiculars to line OO are erected at the points and the TL of the elements abcd are projected horizontally from the FV

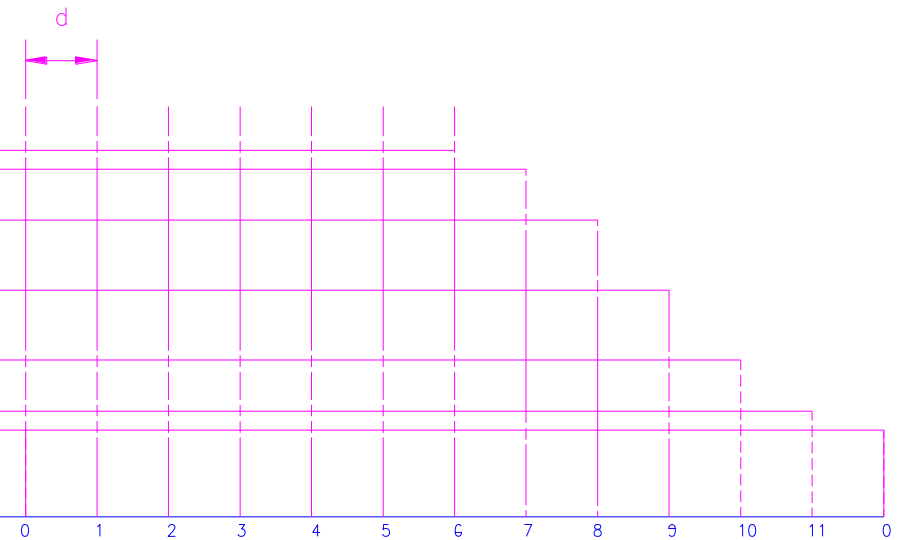

Development of a Right Cylinder

(A) DEVELOPMENTS. RIGHT CIRCULAR CYLINDER.

Every line on a development shows the true length of the corresponding line on the surface.

For economy and simplicity seams should be taken on the shortest line, preferably on a line of symmetry.

Assume chord to be equal to arc.

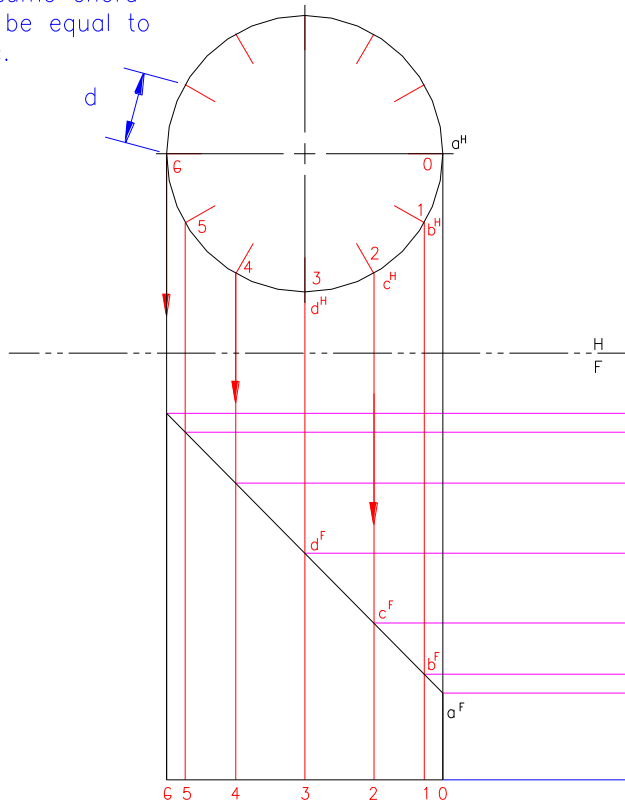

A truncated cylinder is shown, and we use parallel line method to develop this right cylinder

Appropriate number of equally spaced elements is introduced in the TV

The lines are projected from the points in TV to the Front View, where they appear in TL

Length of the stretch out line OO is circumference of the base circle. It is divided into equal number of points as in TV

Perpendiculars to line OO are erected at the points and the TL of the elements abcd are projected horizontally from the FV

Finish the development with the intersection points obtained.

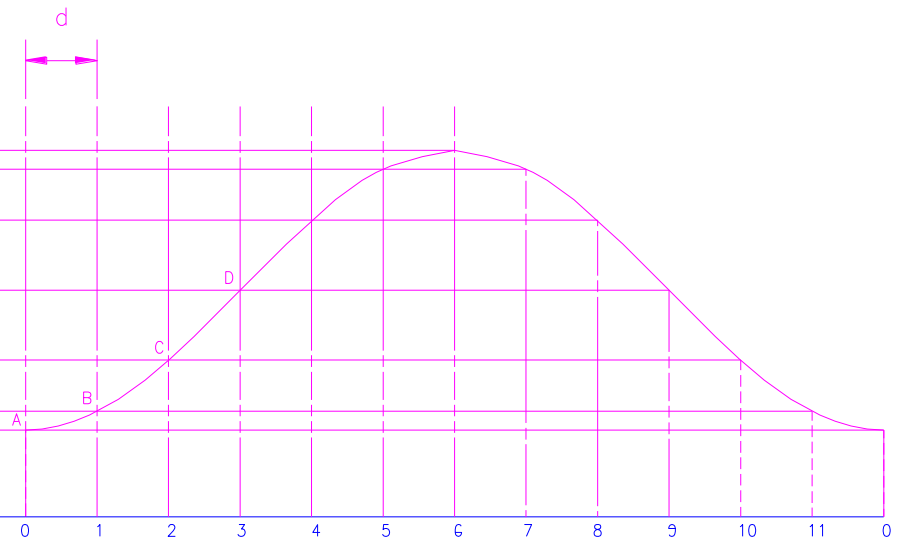

Development of a Right Cylinder

(A) DEVELOPMENTS. RIGHT CIRCULAR CYLINDER.

Every line on a development shows the true length of the corresponding line on the surface.

For economy and simplicity seams should be taken on the shortest line, preferably on a line of symmetry.

Assume chord to be equal to arc.

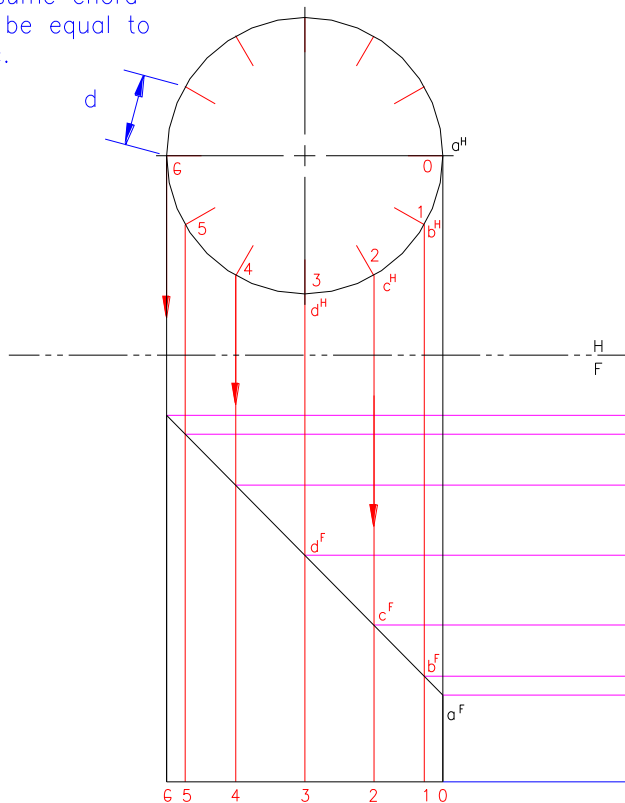

A truncated cylinder is shown, and we use parallel line method to develop this right cylinder

Appropriate number of equally spaced elements is introduced in the TV

The lines are projected from the points in TV to the Front View, where they appear in TL

Length of the stretch out line OO is circumference of the base circle. It is divided into equal number of points as in TV

Perpendiculars to line OO are erected at the points and the TL of the elements abcd are projected horizontally from the FV

Sectioned area shows the development of the truncated right cylinder

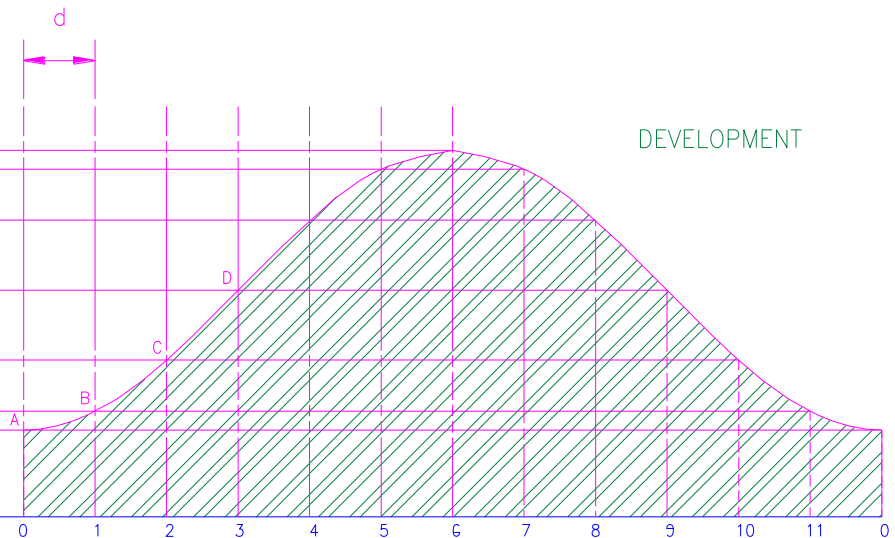

Development of an Oblique Cylinder

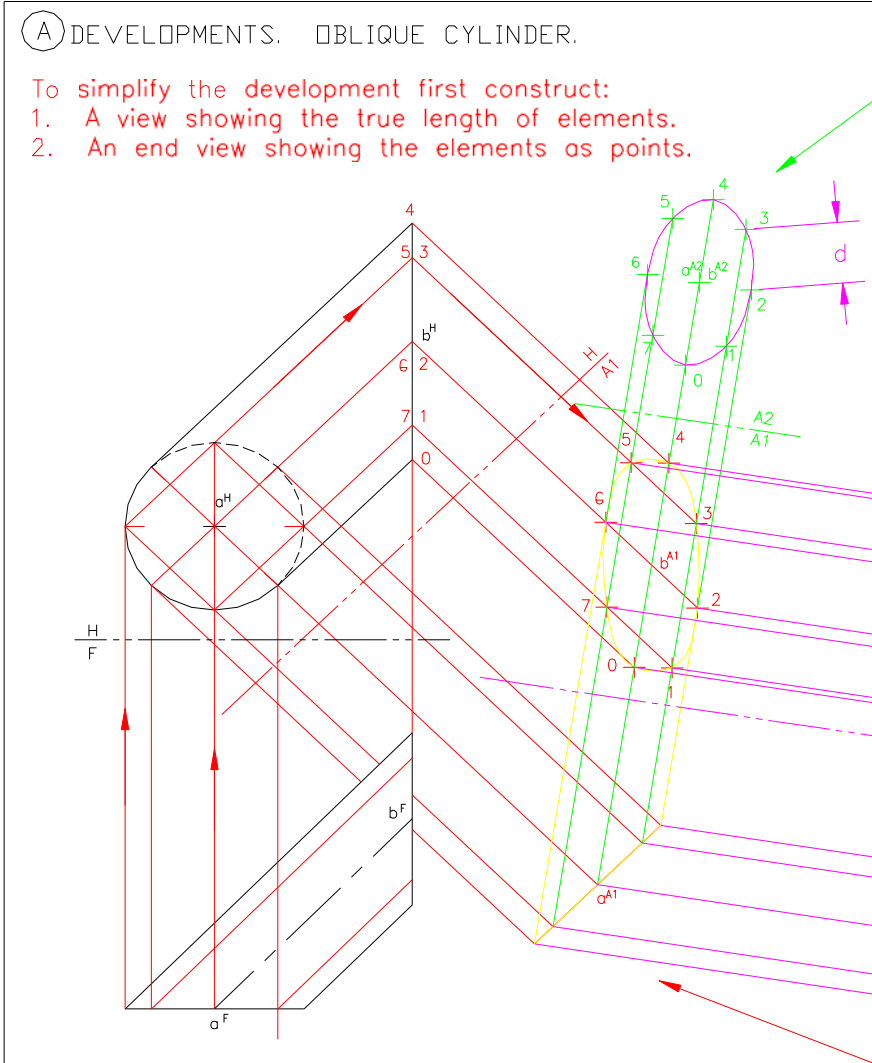

For True Distances between elements.

Chord d is assumed to be equal to arc 23.

DEVELOPMENT (Outside)

For True Lengths of elements

Number	Name	Date	Assignment
L07T05			

Development of an Oblique Cylinder

(A) DEVELOPMENTS. OBLIQUE CYLINDER.

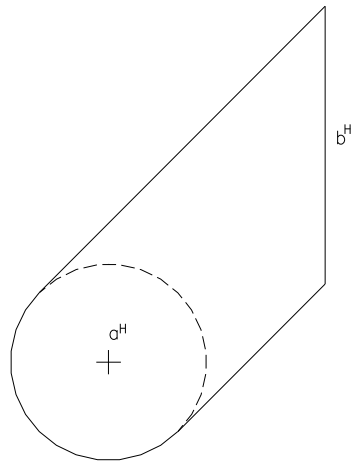

$\frac{H}{F}$

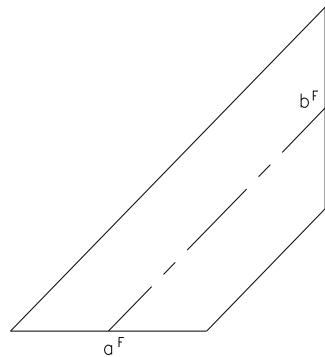

Development of an Oblique Cylinder

(A) DEVELOPMENTS. OBLIQUE CYLINDER.

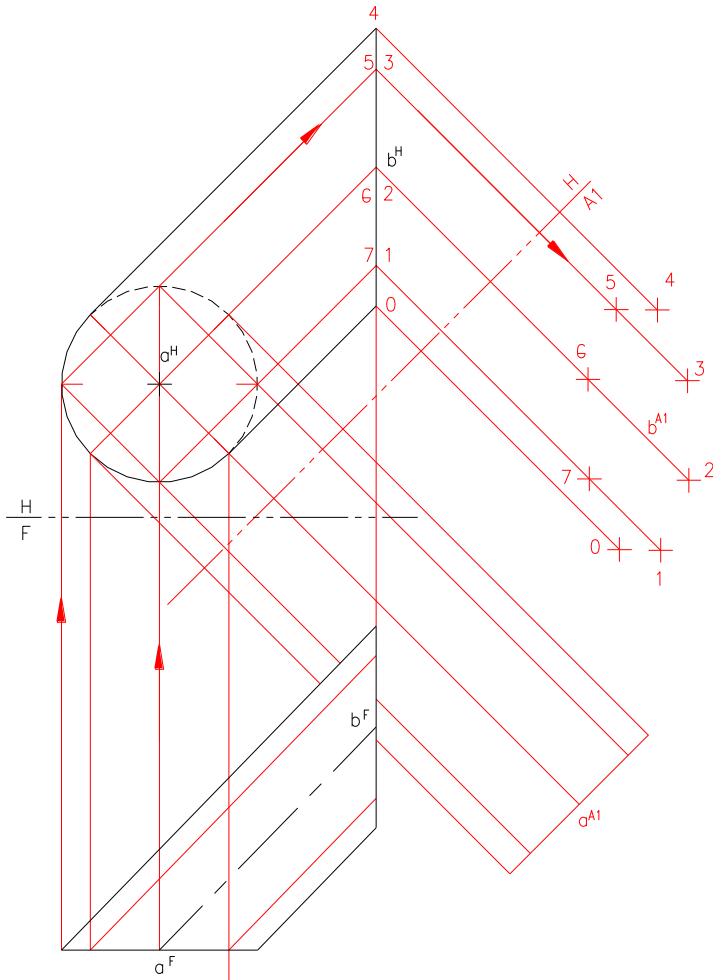

- To simplify the development first construct:
1. A view showing the true length of elements.
 2. An end view showing the elements as points.

Development of an Oblique Cylinder

(A) DEVELOPMENTS. OBLIQUE CYLINDER.

- To simplify the development first construct:
1. A view showing the true length of elements.
 2. An end view showing the elements as points.

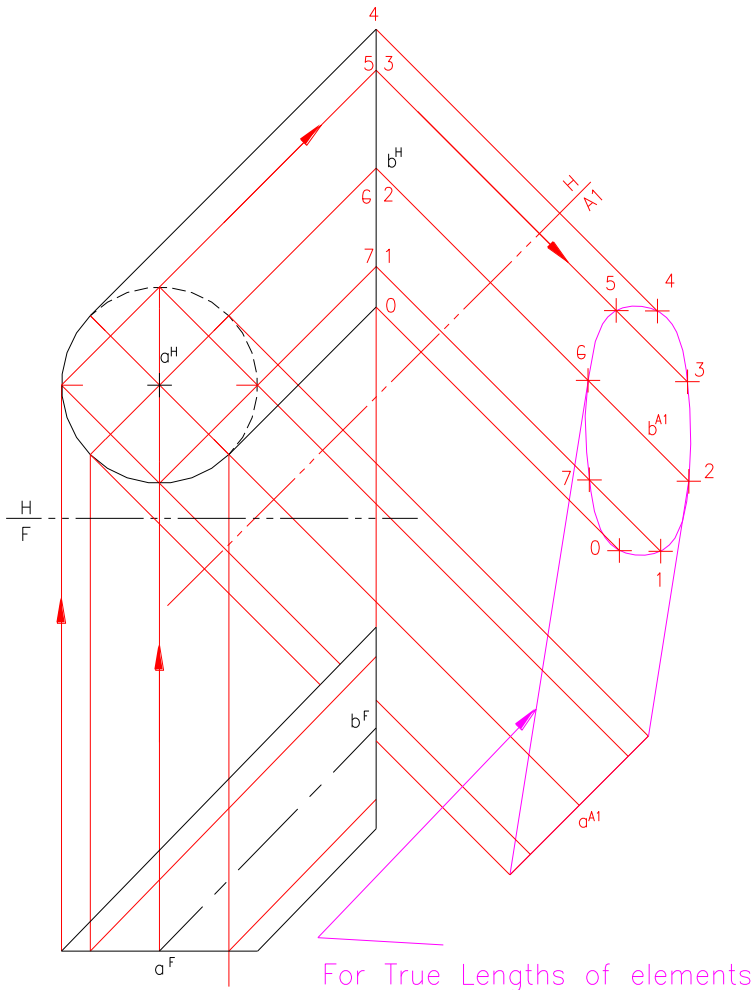

Development of an Oblique Cylinder

(A) DEVELOPMENTS. OBLIQUE CYLINDER.

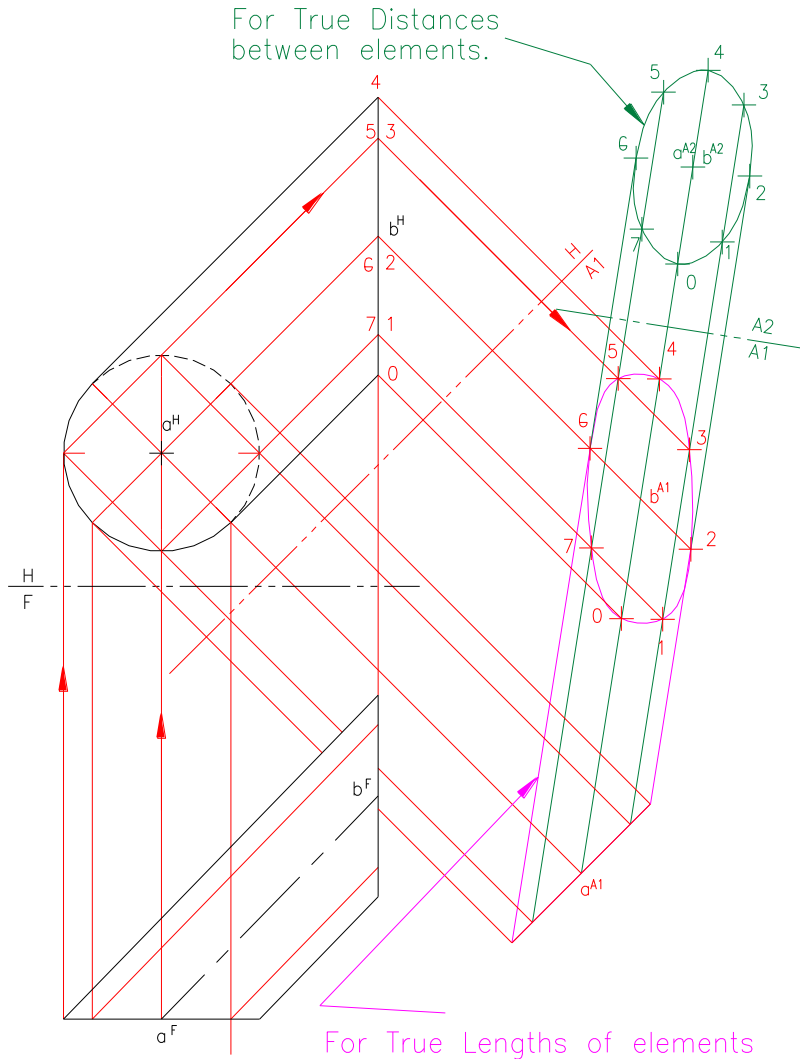

- To simplify the development first construct:
1. A view showing the true length of elements.
 2. An end view showing the elements as points.

Development of an Oblique Cylinder

(A) DEVELOPMENTS. OBLIQUE CYLINDER.

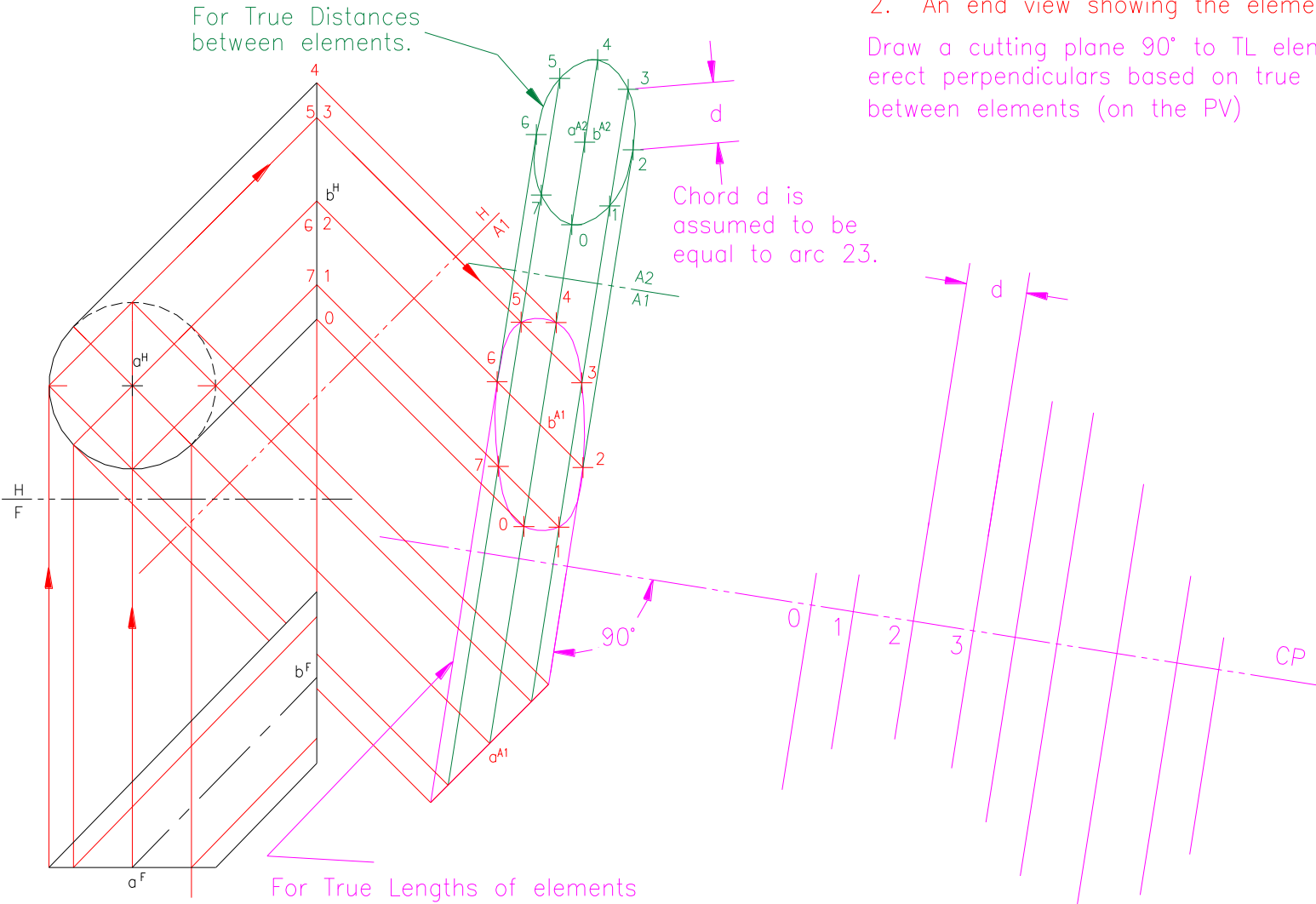

To simplify the development first construct:
 1. A view showing the true length of elements.
 2. An end view showing the elements as points.

Draw a cutting plane 90° to TL elements and erect perpendiculars based on true distances between elements (on the PV)

Development of an Oblique Cylinder

(A) DEVELOPMENTS. OBLIQUE CYLINDER.

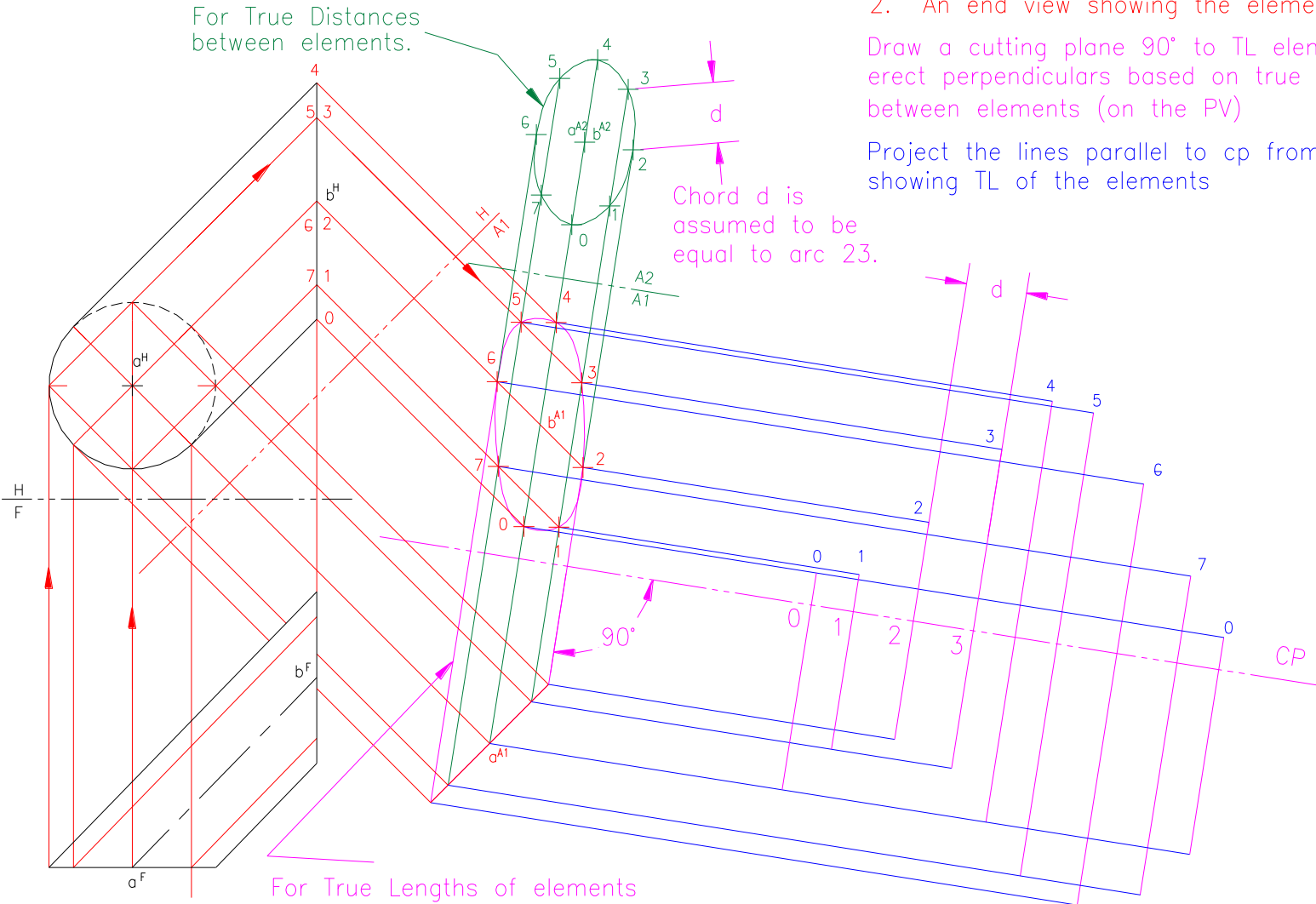

- To simplify the development first construct:
1. A view showing the true length of elements.
 2. An end view showing the elements as points.

Draw a cutting plane 90° to TL elements and erect perpendiculars based on true distances between elements (on the PV)

Project the lines parallel to cp from the view showing TL of the elements

Development of an Oblique Cylinder

(A) DEVELOPMENTS. OBLIQUE CYLINDER.

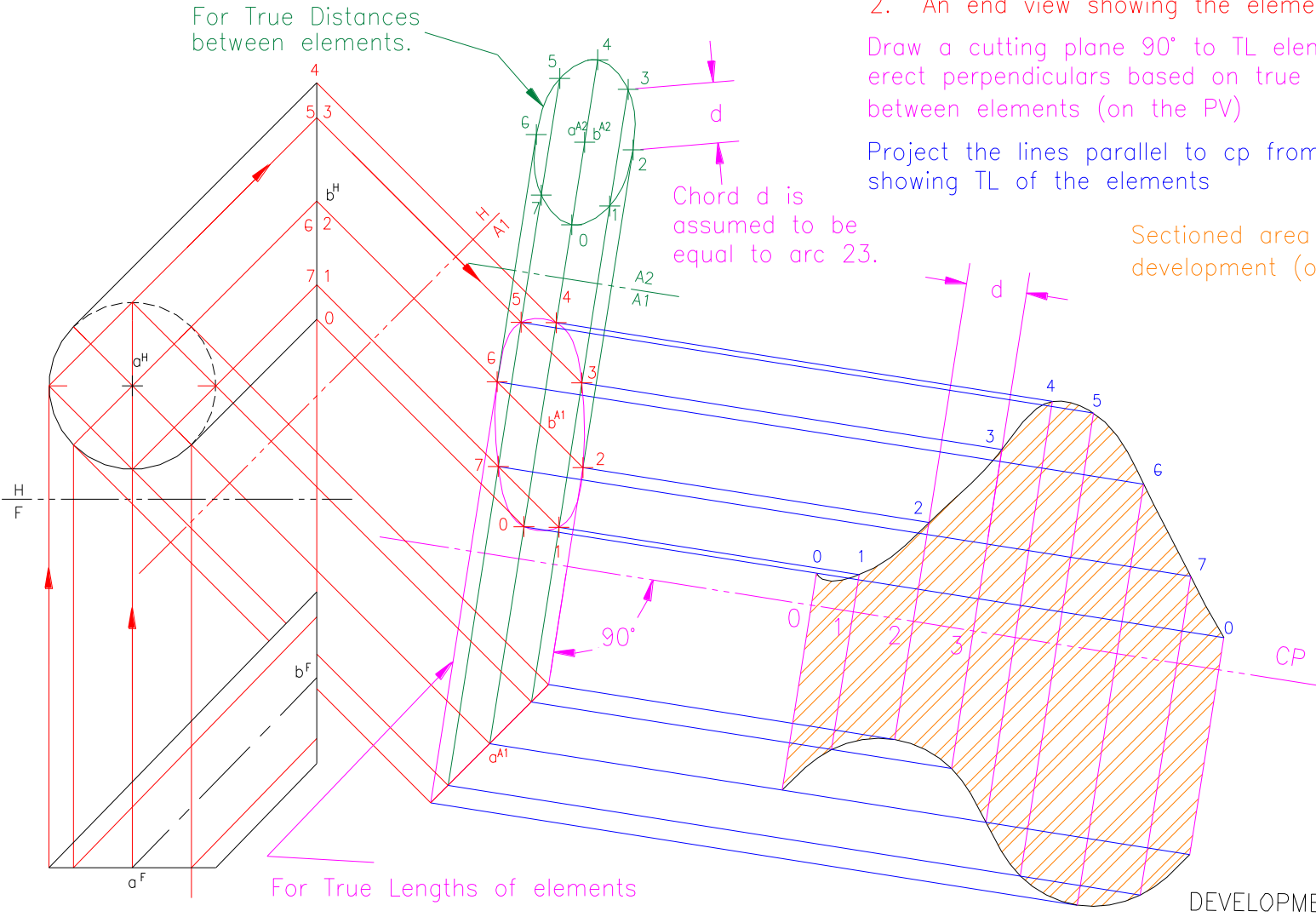

- To simplify the development first construct:
1. A view showing the true length of elements.
 2. An end view showing the elements as points.

Draw a cutting plane 90° to TL elements and erect perpendiculars based on true distances between elements (on the PV)

Project the lines parallel to cp from the view showing TL of the elements

Sectioned area shows the development (outside)

Radial Line Method

- Development of a Right Truncated Cone
- Development of an Oblique Truncated Cone

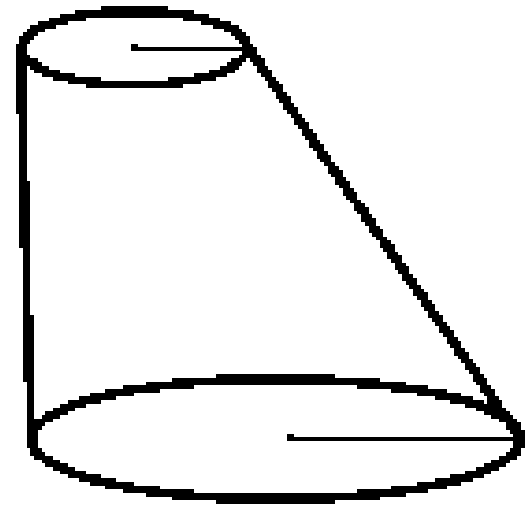
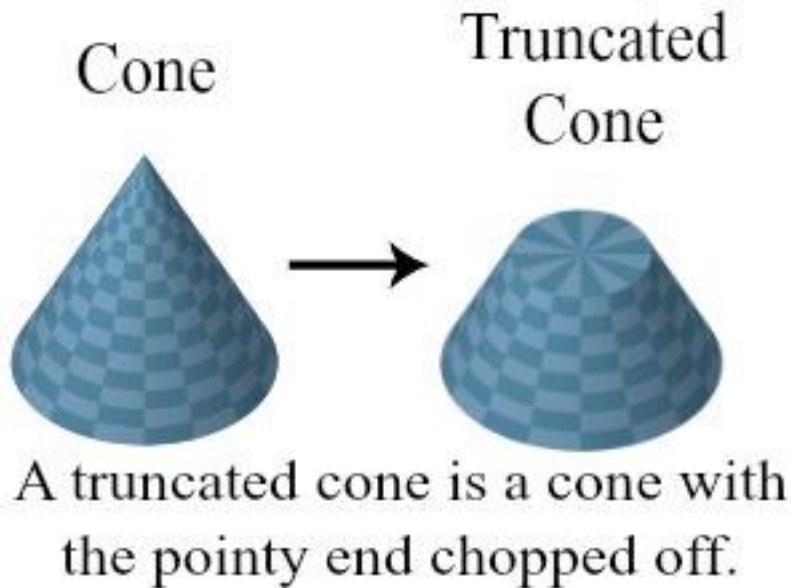

Development of a Right Truncated Cone

(A) DEVELOPMENTS. RIGHT CIRCULAR CONE.

Every line on a development shows the true length of the corresponding line on the surface.

For economy and simplicity seams should be taken on the shortest line, preferably on a line of symmetry.

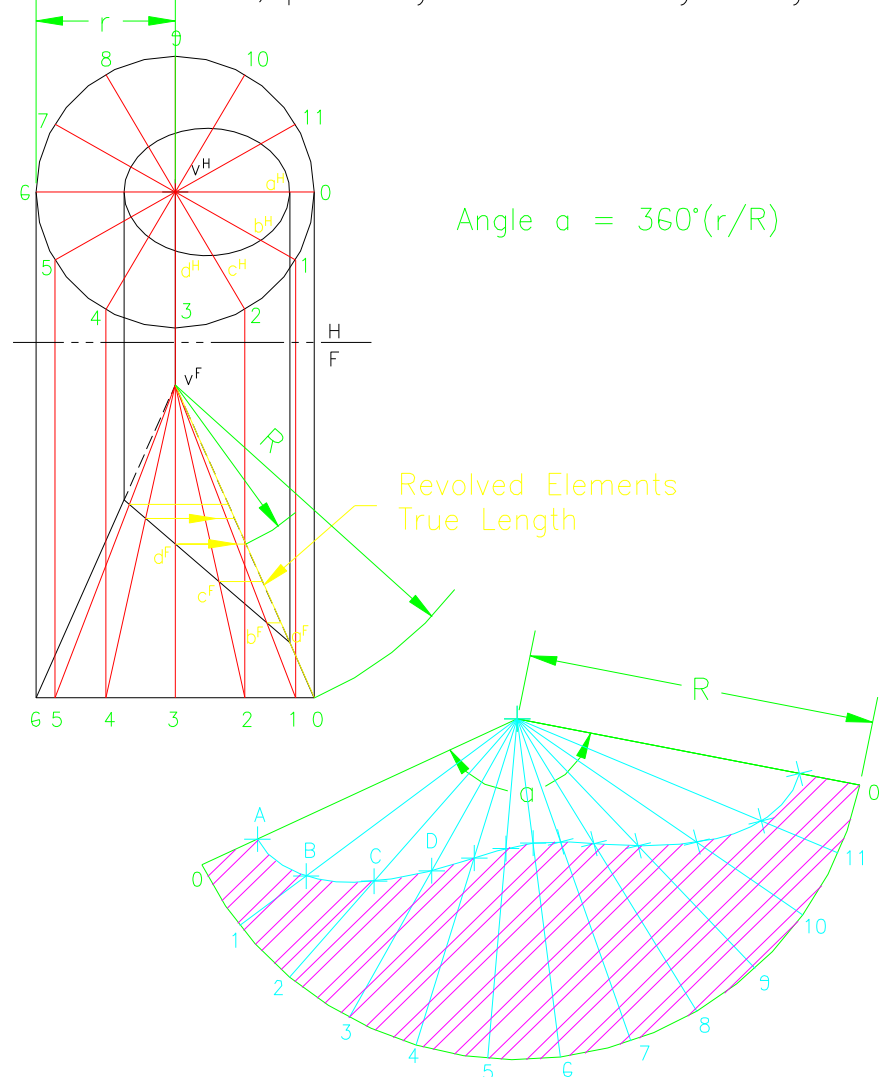

Number
10703

Name

Date

Assignment

Development of a Right Truncated Cone

(A) DEVELOPMENTS. RIGHT CIRCULAR CONE.

Every line on a development shows the true length of the corresponding line on the surface.

For economy and simplicity seams should be taken on the shortest line, preferably on a line of symmetry.

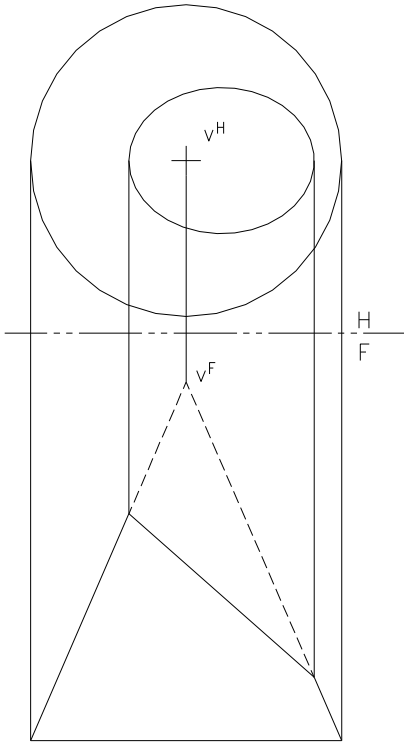

Truncated right cone is given and the development is done by Radial Line method

Development of a Right Truncated Cone

(A) DEVELOPMENTS. RIGHT CIRCULAR CONE.

Every line on a development shows the true length of the corresponding line on the surface.

For economy and simplicity seams should be taken on the shortest line, preferably on a line of symmetry.

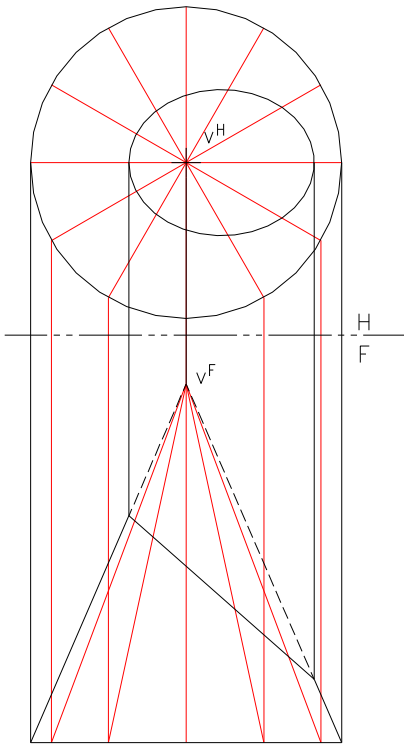

Truncated right cone is given and the development is done by Radial Line method

Consider the only the base circle first.

Divide the circle in the TV to equal parts and project it to the FV and draw elements from the projection to the vertex

Development of a Right Truncated Cone

(A) DEVELOPMENTS. RIGHT CIRCULAR CONE.

Every line on a development shows the true length of the corresponding line on the surface.

For economy and simplicity seams should be taken on the shortest line, preferably on a line of symmetry.

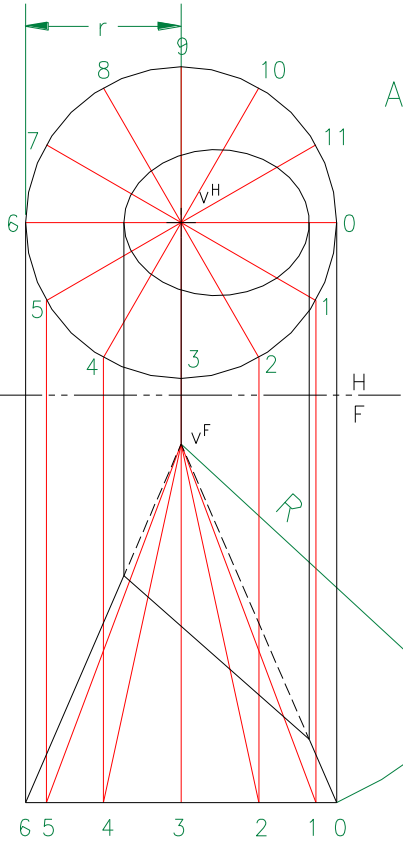

$$\text{Angle } a = 360^\circ(r/R)$$

Truncated right cone is given and the development is done by Radial Line method

Consider the only the base circle first.

Divide the circle in the TV to equal parts and project it to the FV and draw elements from the projection to the vertex

All elements of right cone are same length (slant height) and the development will be a sector of a circle with radius = the TL of the elements and length of the arc being the circumference of the base

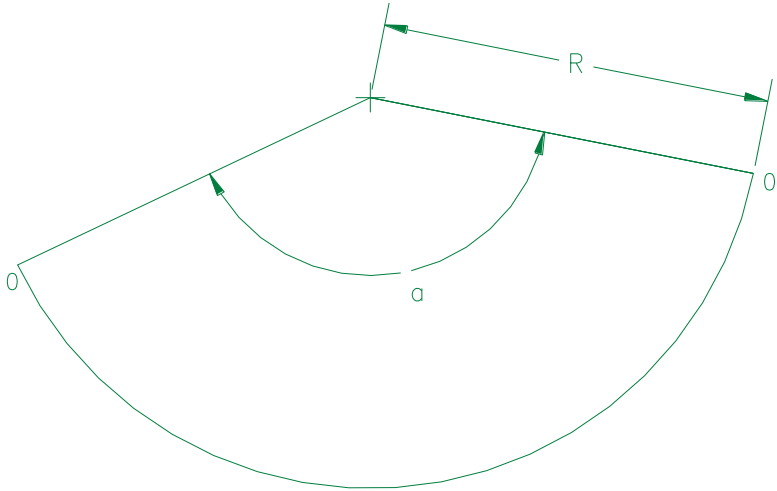

Development of a Right Truncated Cone

(A) DEVELOPMENTS. RIGHT CIRCULAR CONE.

Every line on a development shows the true length of the corresponding line on the surface.

For economy and simplicity seams should be taken on the shortest line, preferably on a line of symmetry.

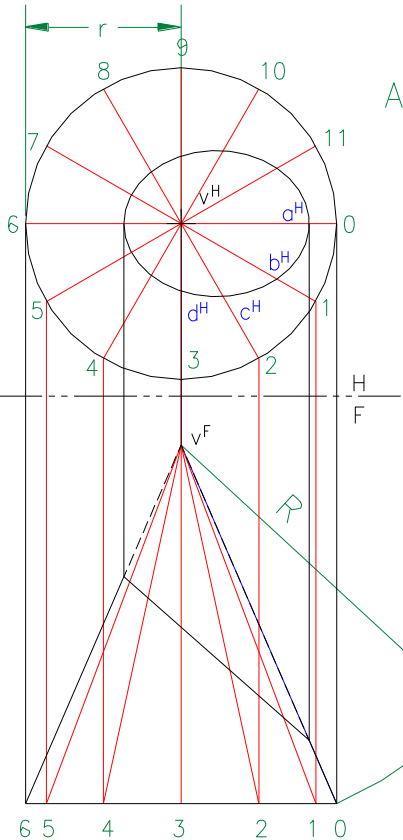

Angle $\alpha = 360^\circ(r/R)$

Truncated right cone is given and the development is done by Radial Line method

Consider the only the base circle first.

Divide the circle in the TV to equal parts and project it to the FV and draw elements from the projection to the vertex

All elements of right cone are same length (slant height) and the development will be a sector of a circle with radius = the TL of the elements and length of the arc being the circumference of the base

Divide the sector equally based on the No of points in TV

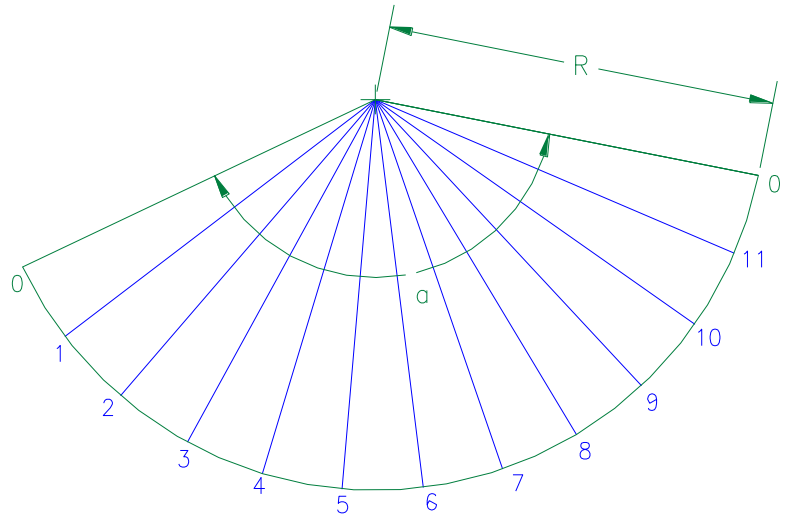

Development of a Right Truncated Cone

(A) DEVELOPMENTS. RIGHT CIRCULAR CONE.

Every line on a development shows the true length of the corresponding line on the surface.

For economy and simplicity seams should be taken on the shortest line, preferably on a line of symmetry.

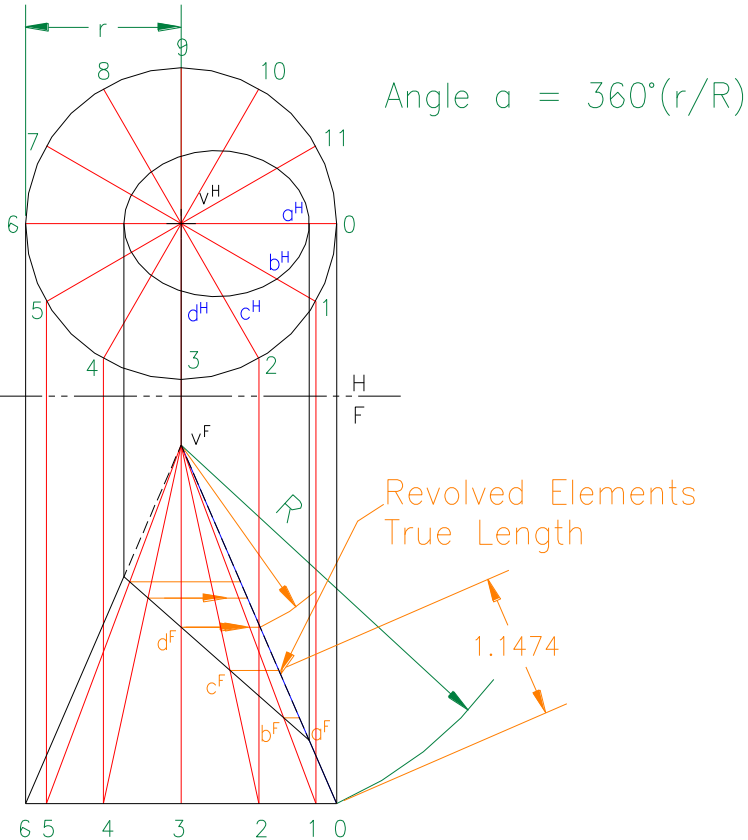

Truncated right cone is given and the development is done by Radial Line method

Consider the only the base circle first.

Divide the circle in the TV to equal parts and project it to the FV and draw elements from the projection to the vertex

All elements of right cone are same length (slant height) and the development will be a sector of a circle with radius = the TL of the elements and length of the arc being the circumference of the base

Divide the sector equally based on the No of points in TV

Mark with points the TL of points a, b, c on the sector. 2C is shown as example

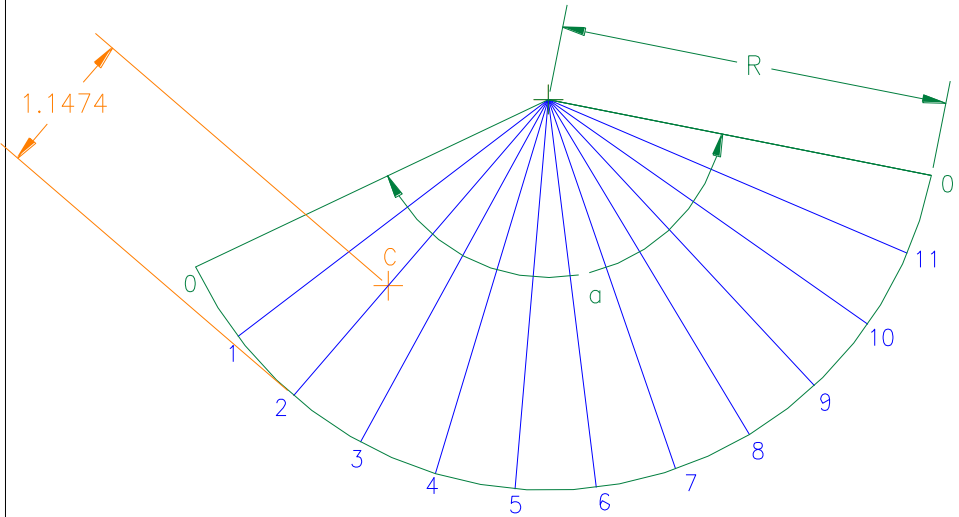

Development of a Right Truncated Cone

(A) DEVELOPMENTS. RIGHT CIRCULAR CONE.

Every line on a development shows the true length of the corresponding line on the surface.

For economy and simplicity seams should be taken on the shortest line, preferably on a line of symmetry.

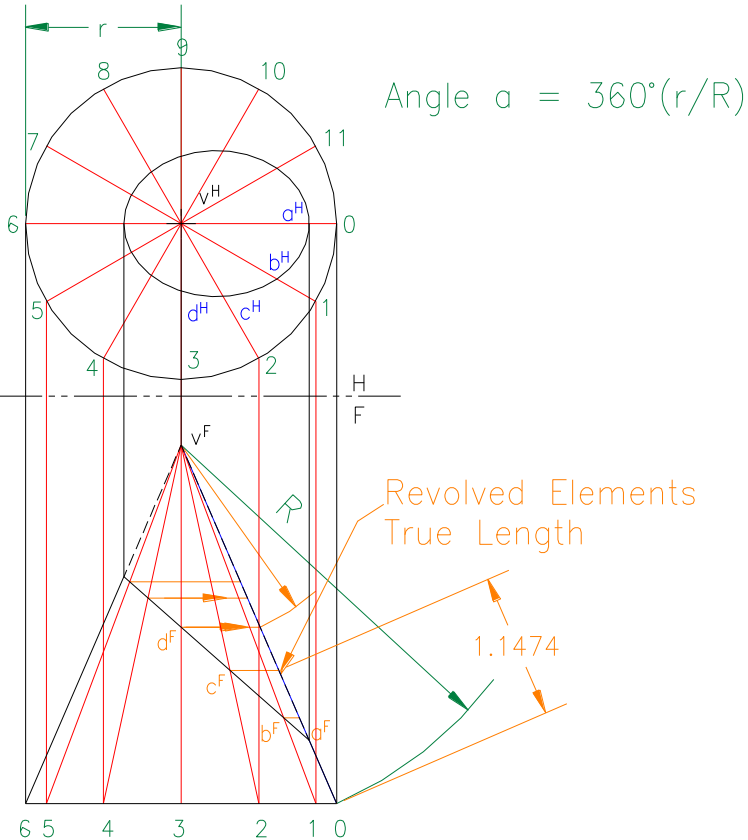

Truncated right cone is given and the development is done by Radial Line method

Consider the only the base circle first.

Divide the circle in the TV to equal parts and project it to the FV and draw elements from the projection to the vertex

All elements of right cone are same length (slant height) and the development will be a sector of a circle with radius = the TL of the elements and length of the arc being the circumference of the base

Divide the sector equally based on the No of points in TV

Mark with points the TL of points a, b, c on the sector. 2C is shown as example

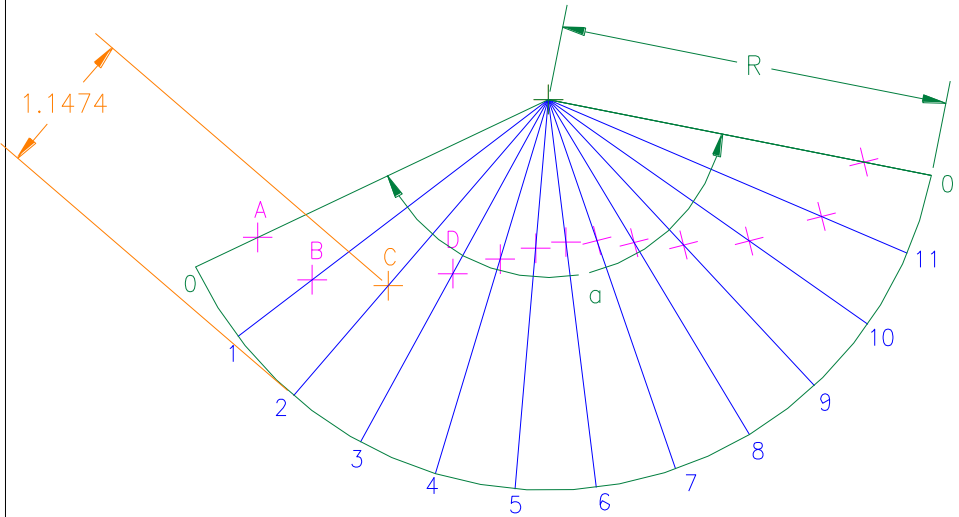

Development of a Right Truncated Cone

(A) DEVELOPMENTS. RIGHT CIRCULAR CONE.

Every line on a development shows the true length of the corresponding line on the surface.

For economy and simplicity seams should be taken on the shortest line, preferably on a line of symmetry.

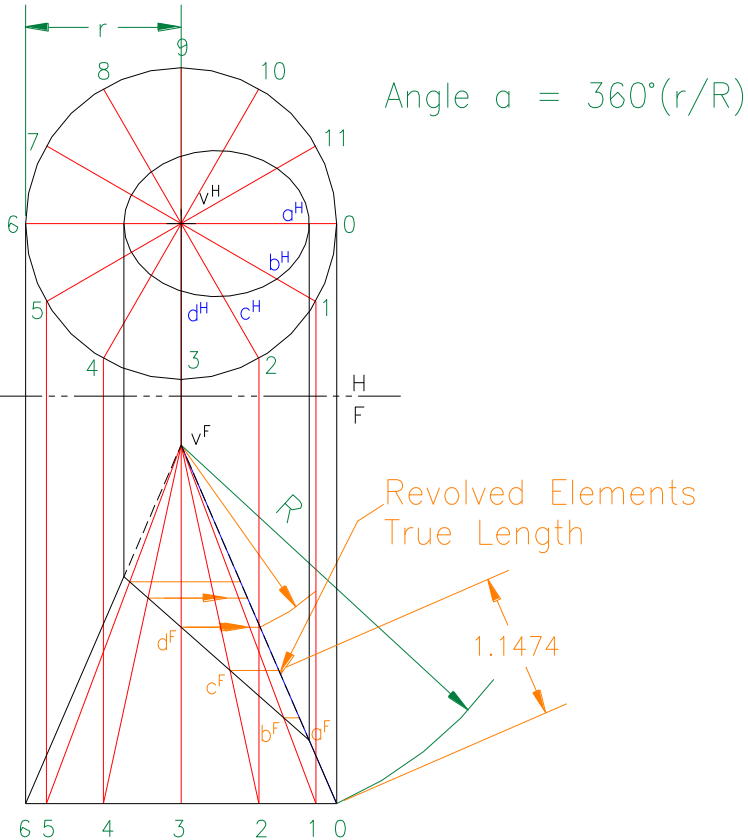

Truncated right cone is given and the development is done by Radial Line method

Consider the only the base circle first.

Divide the circle in the TV to equal parts and project it to the FV and draw elements from the projection to the vertex

All elements of right cone are same length (slant height) and the development will be a sector of a circle with radius = the TL of the elements and length of the arc being the circumference of the base

Divide the sector equally based on the No of points in TV

Mark with points the TL of points a, b, c on the sector. 2C is shown as example

Connect all the points to get the development of truncated right cone

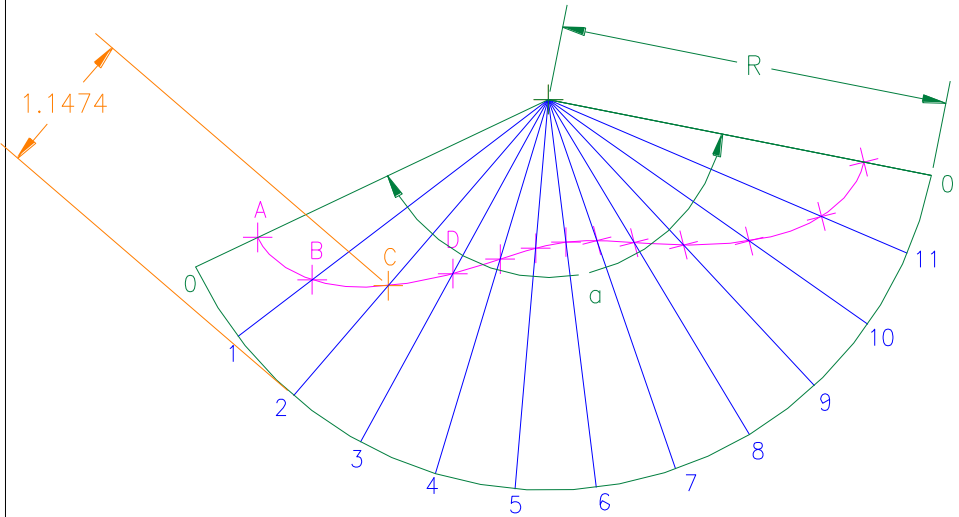

Development of a Right Truncated Cone

(A) DEVELOPMENTS. RIGHT CIRCULAR CONE.

Every line on a development shows the true length of the corresponding line on the surface.

For economy and simplicity seams should be taken on the shortest line, preferably on a line of symmetry.

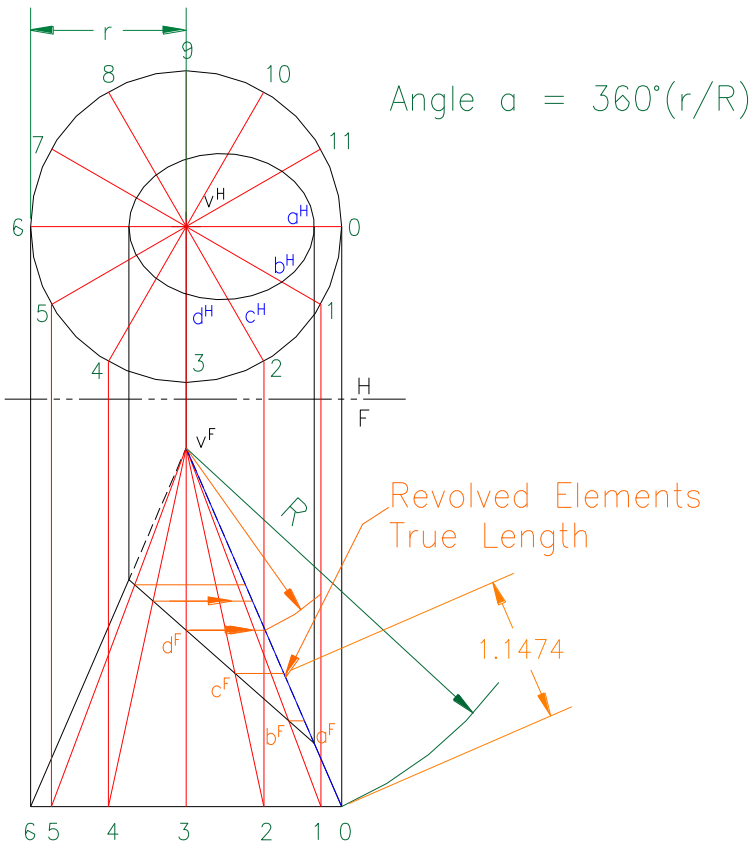

Truncated right cone is given and the development is done by Radial Line method

Consider the only the base circle first.

Divide the circle in the TV to equal parts and project it to the FV and draw elements from the projection to the vertex

All elements of right cone are same length (slant height) and the development will be a sector of a circle with radius = the TL of the elements and length of the arc being the circumference of the base

Divide the sector equally based on the No of points in TV

Mark with points the TL of points a, b, c on the sector. 2C is shown as example

Connect all the points to get the development of truncated right cone

Sectioned area shows development

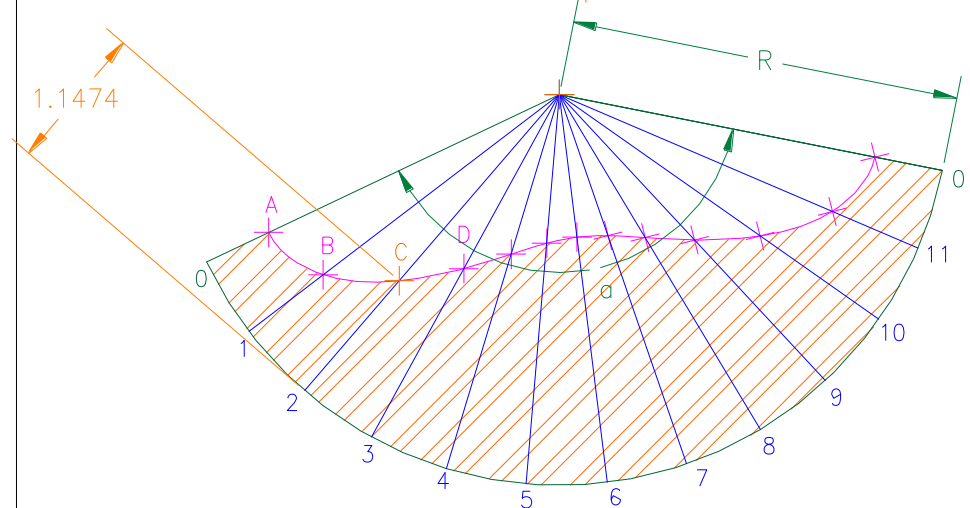

Development of an Oblique Truncated Cone - Triangulation

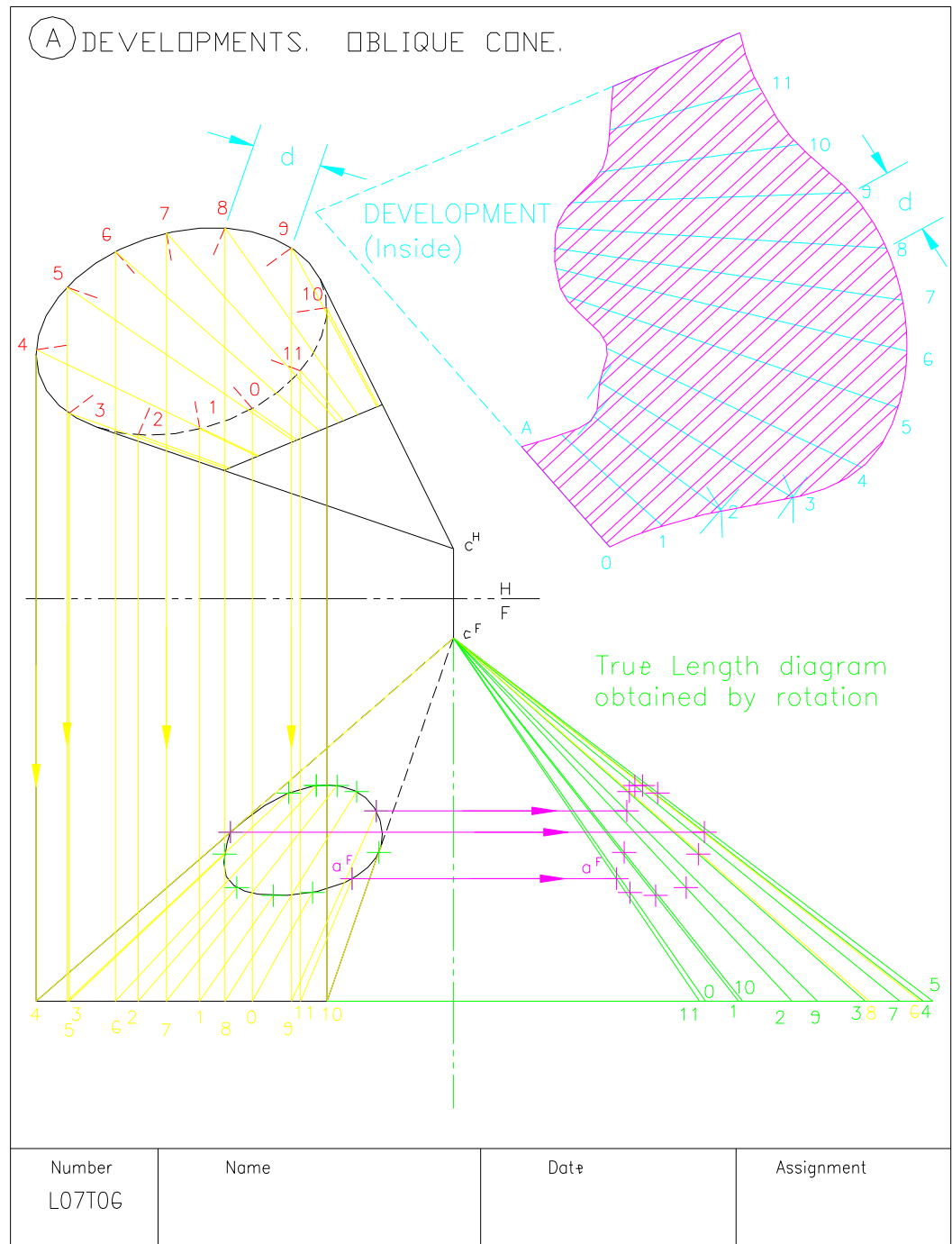

Development of an Oblique Truncated Cone Triangulation Method

(A) DEVELOPMENTS OBLIQUE CONE

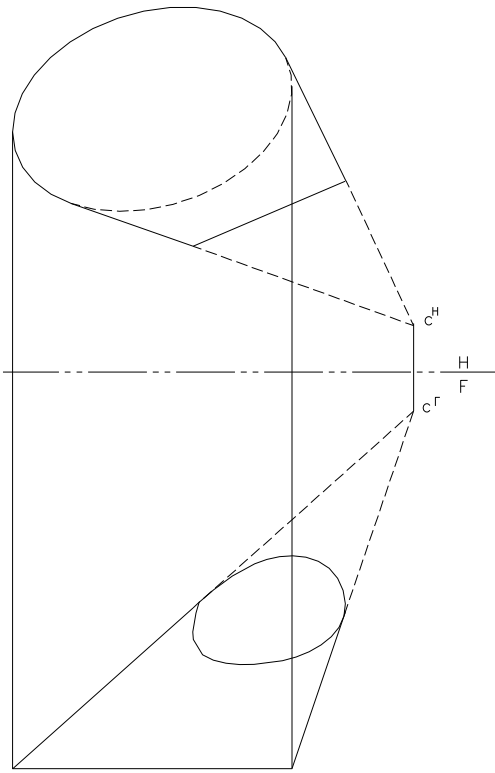

In oblique cone, the radial lines are not equal so even if the base is circular, it will not develop as a circular arc. It is hence assumed that the surface between consecutive elements is narrow enough so that approximation can be done.

Development of an Oblique Truncated Cone Triangulation Method

(A) DEVELOPMENTS. OBLIQUE CONE.

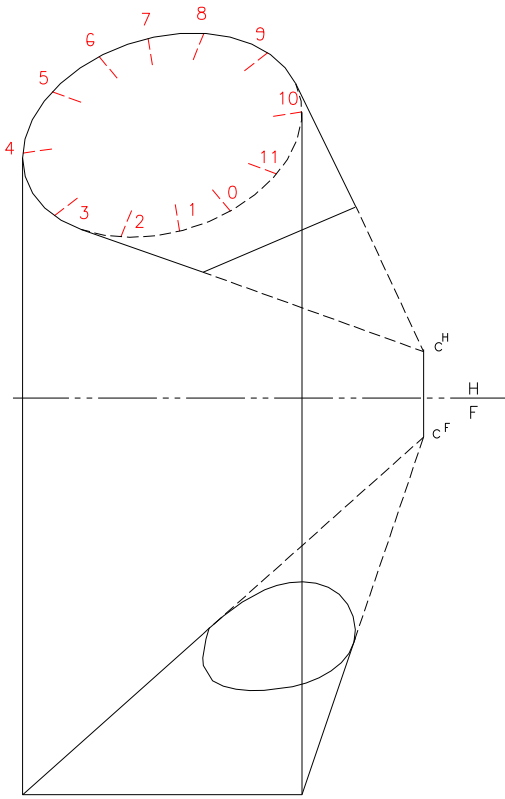

In oblique cone, the radial lines are not equal so even if the base is circular, it will not develop as a circular arc. It is hence assumed that the surface between consecutive elements is narrow enough so that approximation can be done.

The base is an ellipse and is divided into 12 equal parts and the elements are drawn in each view

Development of an Oblique Truncated Cone Triangulation Method

(A) DEVELOPMENTS. OBLIQUE CONE.

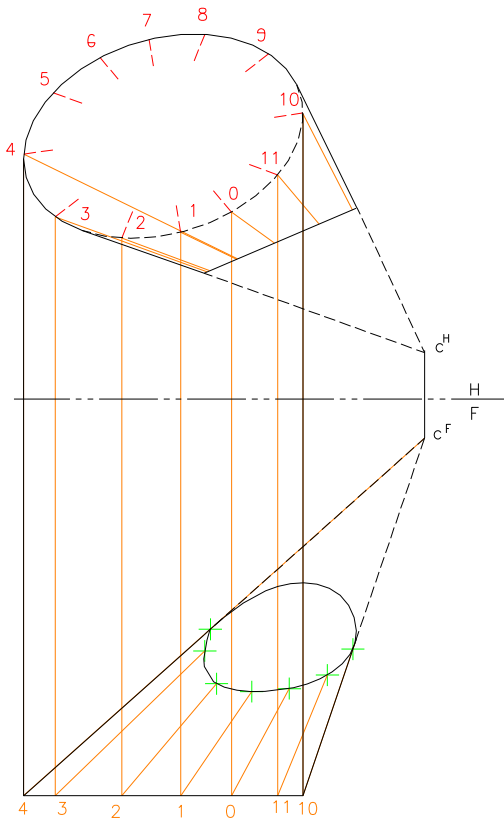

In oblique cone, the radial lines are not equal so even if the base is circular, it will not develop as a circular arc. It is hence assumed that the surface between consecutive elements is narrow enough so that approximation can be done.

The base is an ellipse and is divided into 12 equal parts and the elements are drawn in each view

Development of an Oblique Truncated Cone Triangulation Method

(A) DEVELOPMENTS. OBLIQUE CONE.

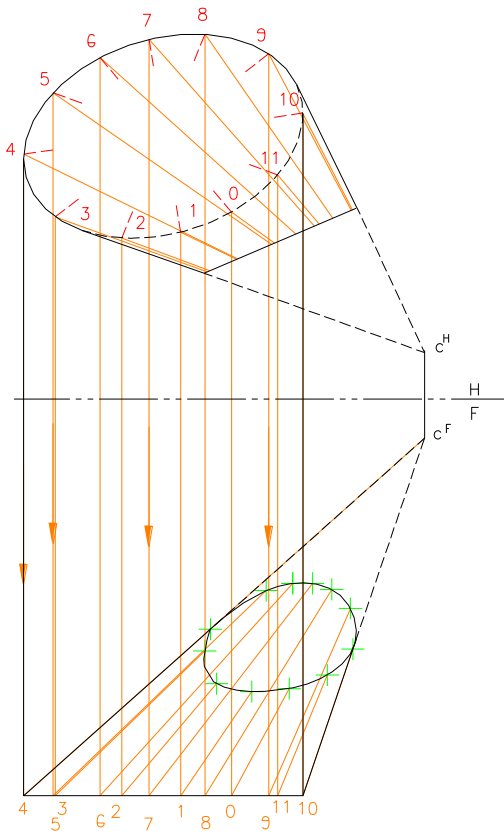

In oblique cone, the radial lines are not equal so even if the base is circular, it will not develop as a circular arc. It is hence assumed that the surface between consecutive elements is narrow enough so that approximation can be done.

The base is an ellipse and is divided into 12 equal parts and the elements are drawn in each view

Development of an Oblique Truncated Cone Triangulation Method

(A) DEVELOPMENTS. OBLIQUE CONE.

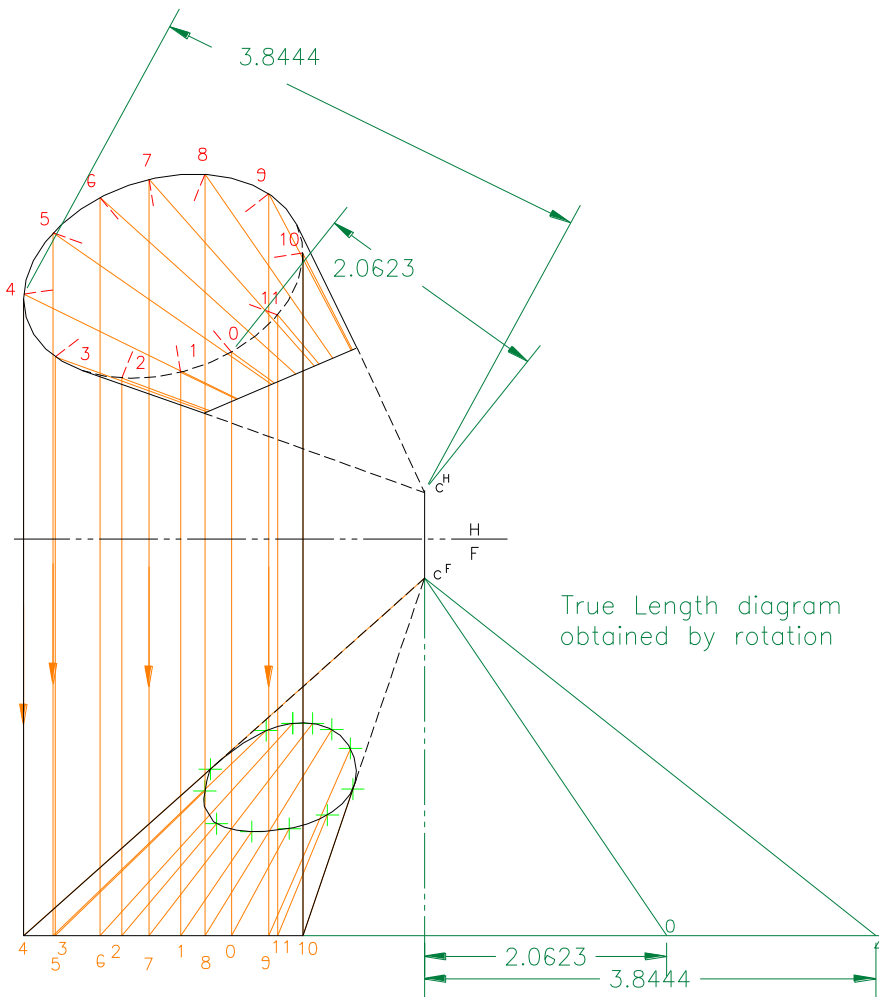

In oblique cone, the radial lines are not equal so even if the base is circular, it will not develop as a circular arc. It is hence assumed that the surface between consecutive elements is narrow enough so that approximation can be done.

The base is an ellipse and is divided into 12 equal parts and the elements are drawn in each view

The TL of the elements are drawn adjacent to FV based on the dimensions in the TV. Eg. for elements 0 and 4 shown. Repeat for all other elements as well

Development of an Oblique Truncated Cone Triangulation Method

(A) DEVELOPMENTS. OBLIQUE CONE.

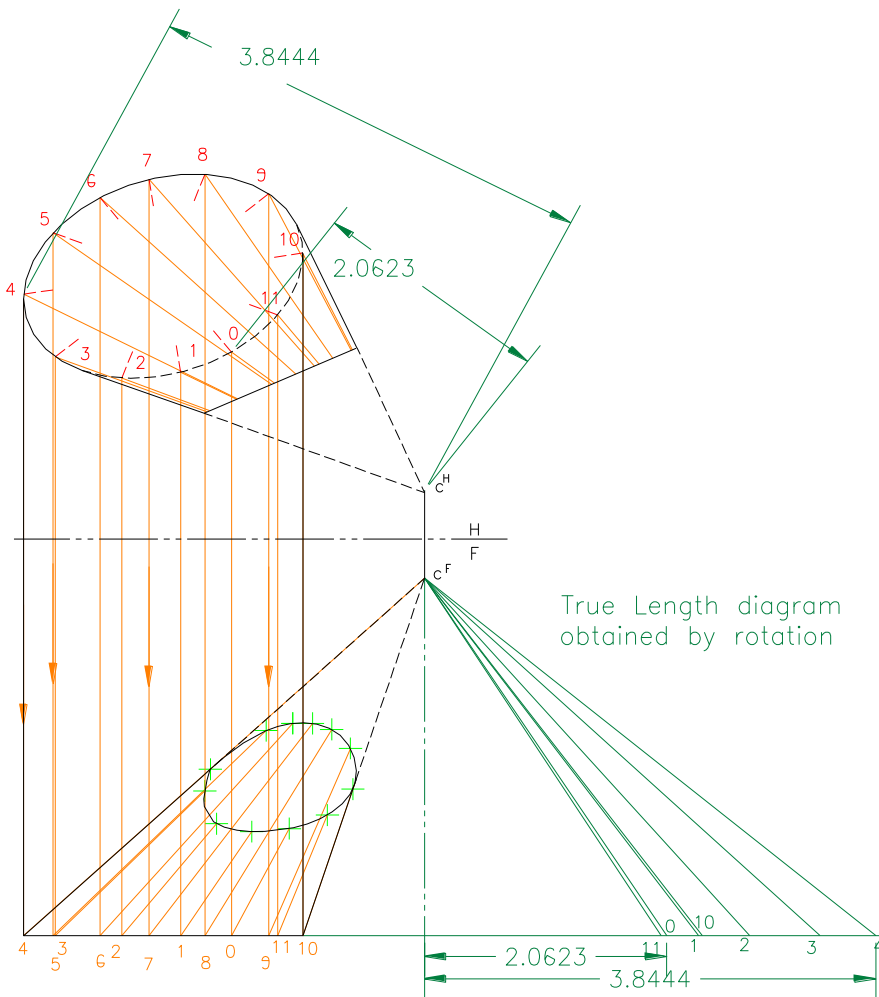

In oblique cone, the radial lines are not equal so even if the base is circular, it will not develop as a circular arc. It is hence assumed that the surface between consecutive elements is narrow enough so that approximation can be done.

The base is an ellipse and is divided into 12 equal parts and the elements are drawn in each view

The TL of the elements are drawn adjacent to FV based on the dimensions in the TV. Eg. for elements 0 and 4 shown. Repeat for all other elements as well

Development of an Oblique Truncated Cone Triangulation Method

(A) DEVELOPMENTS. OBLIQUE CONE.

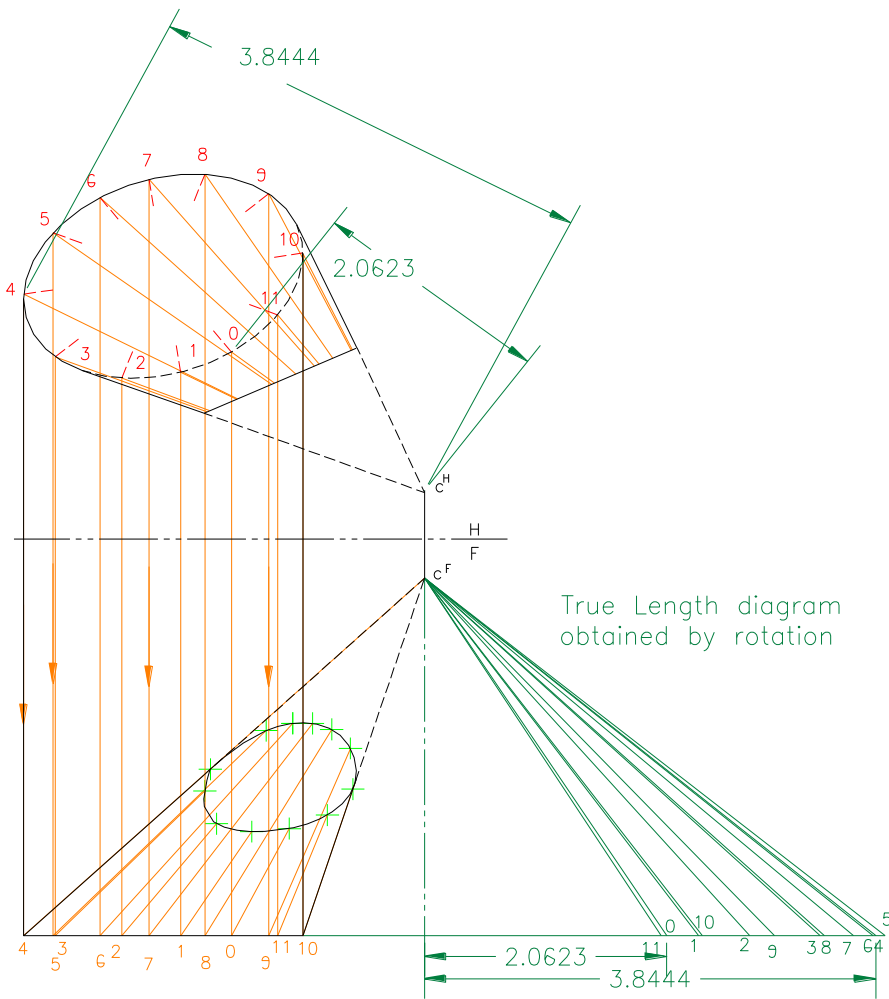

In oblique cone, the radial lines are not equal so even if the base is circular, it will not develop as a circular arc. It is hence assumed that the surface between consecutive elements is narrow enough so that approximation can be done.

The base is an ellipse and is divided into 12 equal parts and the elements are drawn in each view

The TL of the elements are drawn adjacent to FV based on the dimensions in the TV. Eg. for elements 0 and 4 shown. Repeat for all other elements as well

Development of an Oblique Truncated Cone Triangulation Method

(A) DEVELOPMENTS. OBLIQUE CONE.

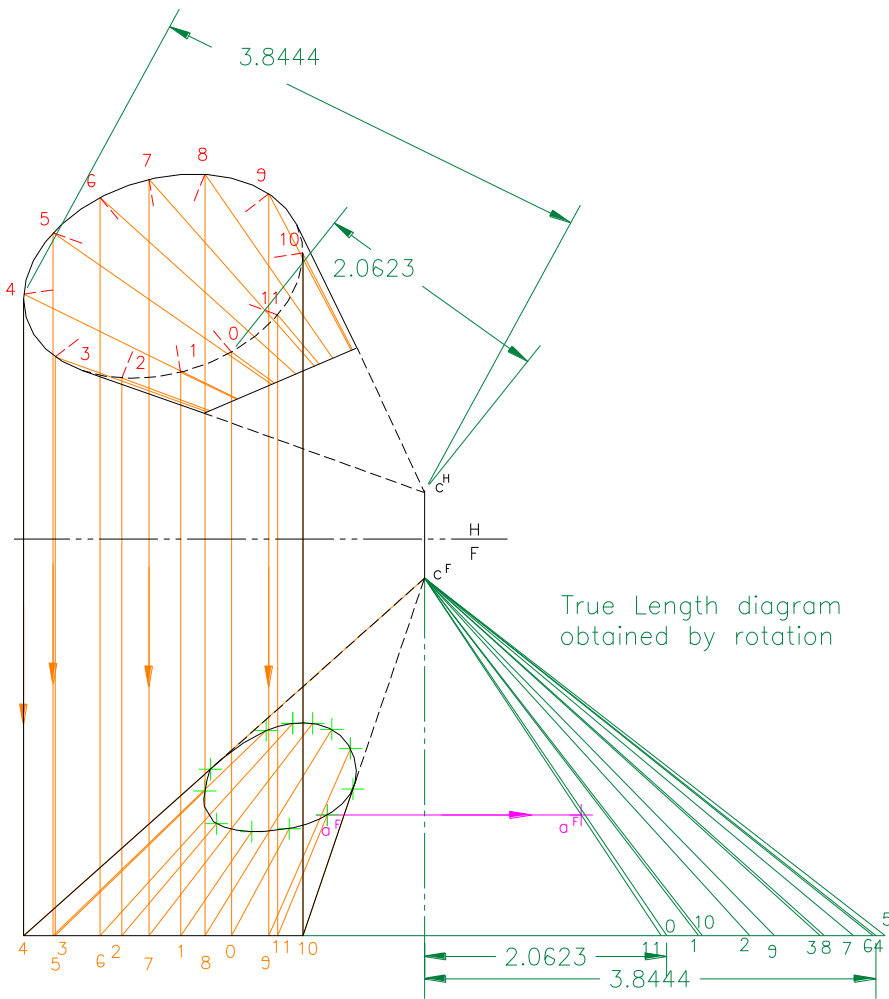

In oblique cone, the radial lines are not equal so even if the base is circular, it will not develop as a circular arc. It is hence assumed that the surface between consecutive elements is narrow enough so that approximation can be done.

The base is an ellipse and is divided into 12 equal parts and the elements are drawn in each view

The TL of the elements are drawn adjacent to FV based on the dimensions in the TV. Eg. for elements 0 and 4 shown. Repeat for all other elements as well

Project points from the FV to the TL view on the proper elements. aF is projected onto 11V as example here. Similarly project other points.

Development of an Oblique Truncated Cone Triangulation Method

(A) DEVELOPMENTS. OBLIQUE CONE.

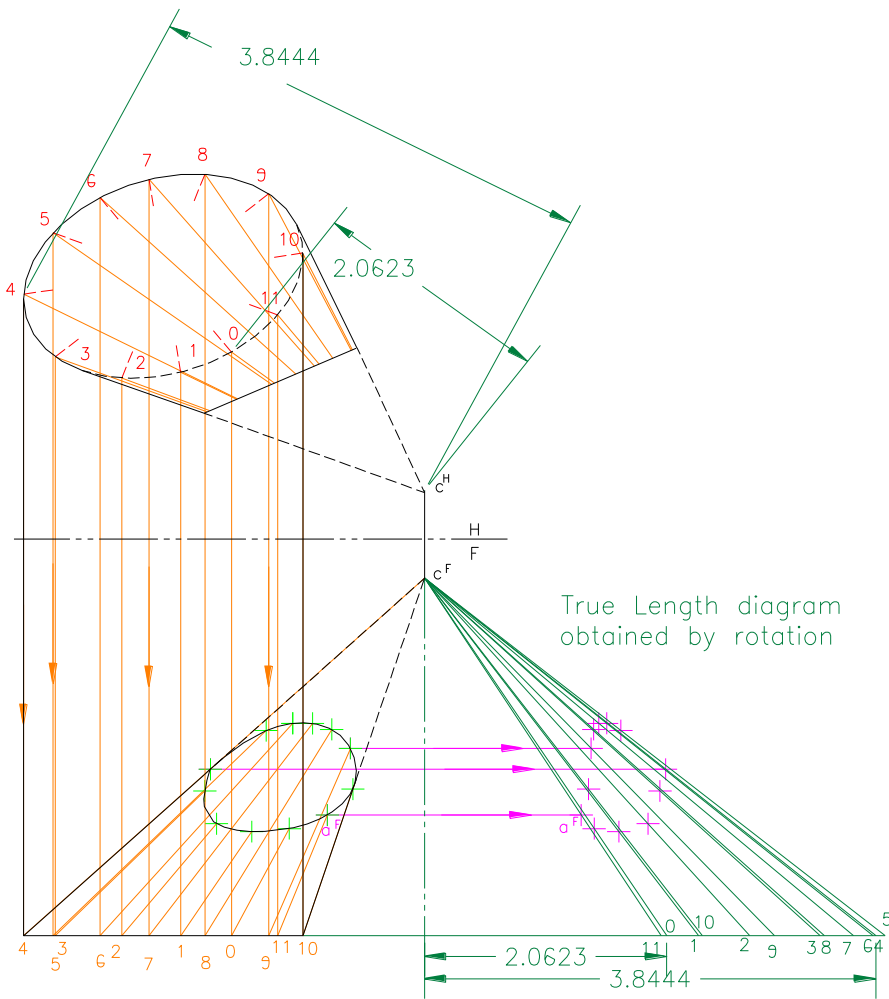

In oblique cone, the radial lines are not equal so even if the base is circular, it will not develop as a circular arc. It is hence assumed that the surface between consecutive elements is narrow enough so that approximation can be done.

The base is an ellipse and is divided into 12 equal parts and the elements are drawn in each view

The TL of the elements are drawn adjacent to FV based on the dimensions in the TV. Eg. for elements 0 and 4 shown. Repeat for all other elements as well

Project points from the FV to the TL view on the proper elements. aF is projected onto 11V as example here. Similarly project other points.

Development of an Oblique Truncated Cone Triangulation Method

(A) DEVELOPMENTS. OBLIQUE CONE.

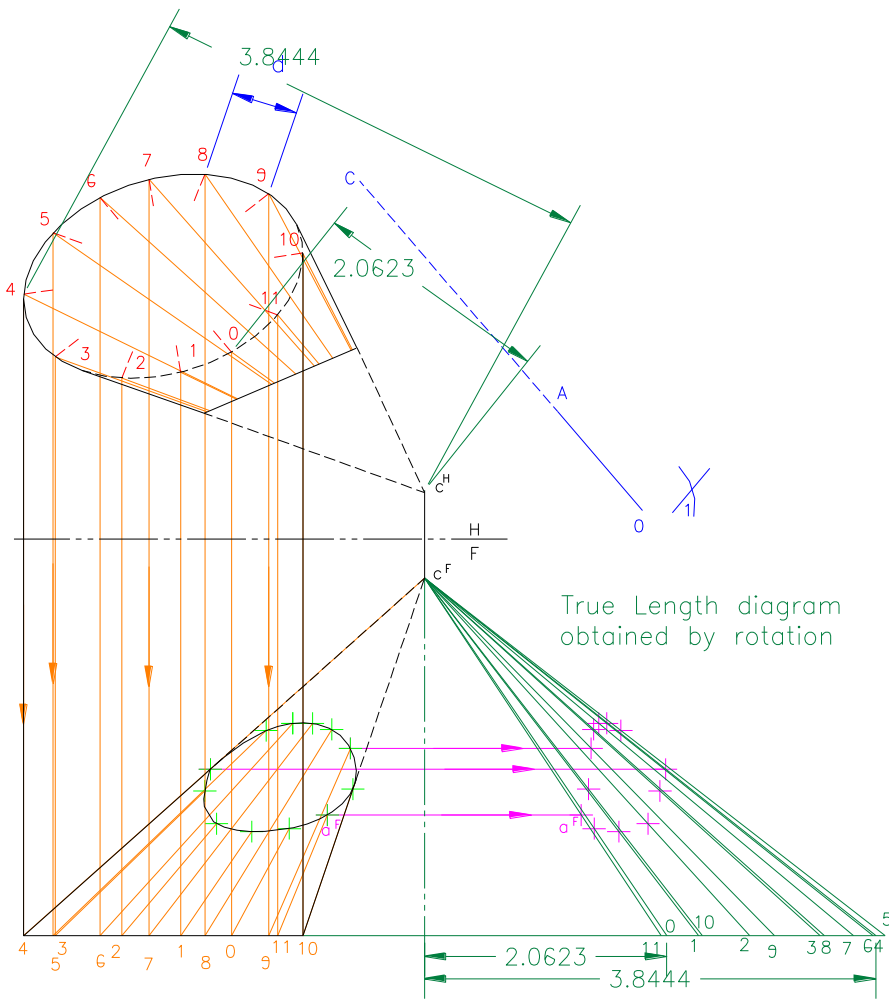

In oblique cone, the radial lines are not equal so even if the base is circular, it will not develop as a circular arc. It is hence assumed that the surface between consecutive elements is narrow enough so that approximation can be done.

The base is an ellipse and is divided into 12 equal parts and the elements are drawn in each view

The TL of the elements are drawn adjacent to FV based on the dimensions in the TV. Eg. for elements 0 and 4 shown. Repeat for all other elements as well

Project points from the FV to the TL view on the proper elements. aF is projected onto 11V as example here. Similarly project other points.

For the development, cone appears TS in the TV hence the chordal distances can be transferred directly.

First radial line V0 can be positioned as desired. Then a small arc with radius C1 (TL view) is cut from Centre as C. With centre in 0 and radius as chordal distance 0-1, another arc is cut to intersect the previous one. this is the point 1 in development of the base

Development of an Oblique Truncated Cone Triangulation Method

(A) DEVELOPMENTS. OBLIQUE CONE.

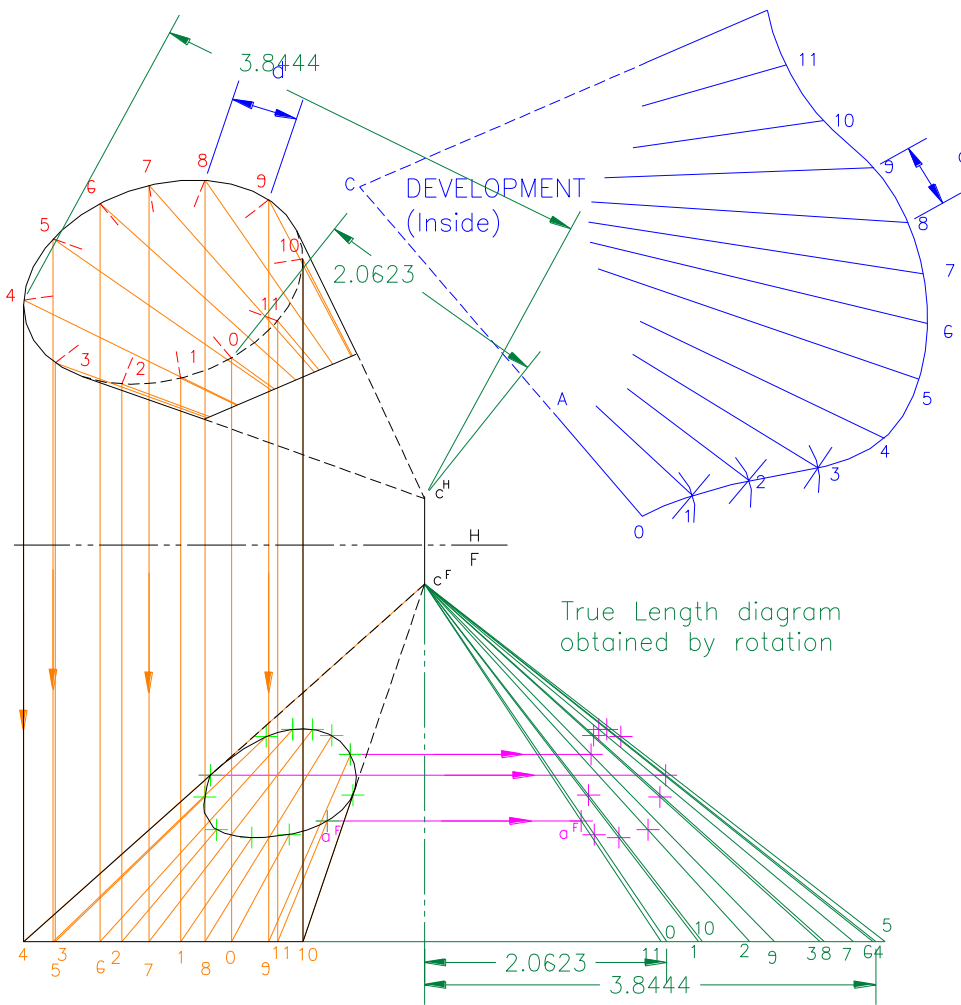

In oblique cone, the radial lines are not equal so even if the base is circular, it will not develop as a circular arc. It is hence assumed that the surface between consecutive elements is narrow enough so that approximation can be done.

The base is an ellipse and is divided into 12 equal parts and the elements are drawn in each view

The TL of the elements are drawn adjacent to FV based on the dimensions in the TV. Eg. for elements 0 and 4 shown. Repeat for all other elements as well

Project points from the FV to the TL view on the proper elements. aF is projected onto 11V as example here. Similarly project other points.

For the development, cone appears TS in the TV hence the chordal distances can be transferred directly.

First radial line $V0$ can be positioned as desired. Then a small arc with radius $C1$ (TL view) is cut from Centre as C . With centre in 0 and radius as chordal distance $0-1$, another arc is cut to intersect the previous one. this is the point 1 in development of the base

Similarly other points are located and a smooth curve drawn between them locates the development of the base. The angular spacing is not equal.

Development of an Oblique Truncated Cone Triangulation Method

(A) DEVELOPMENTS. OBLIQUE CONE.

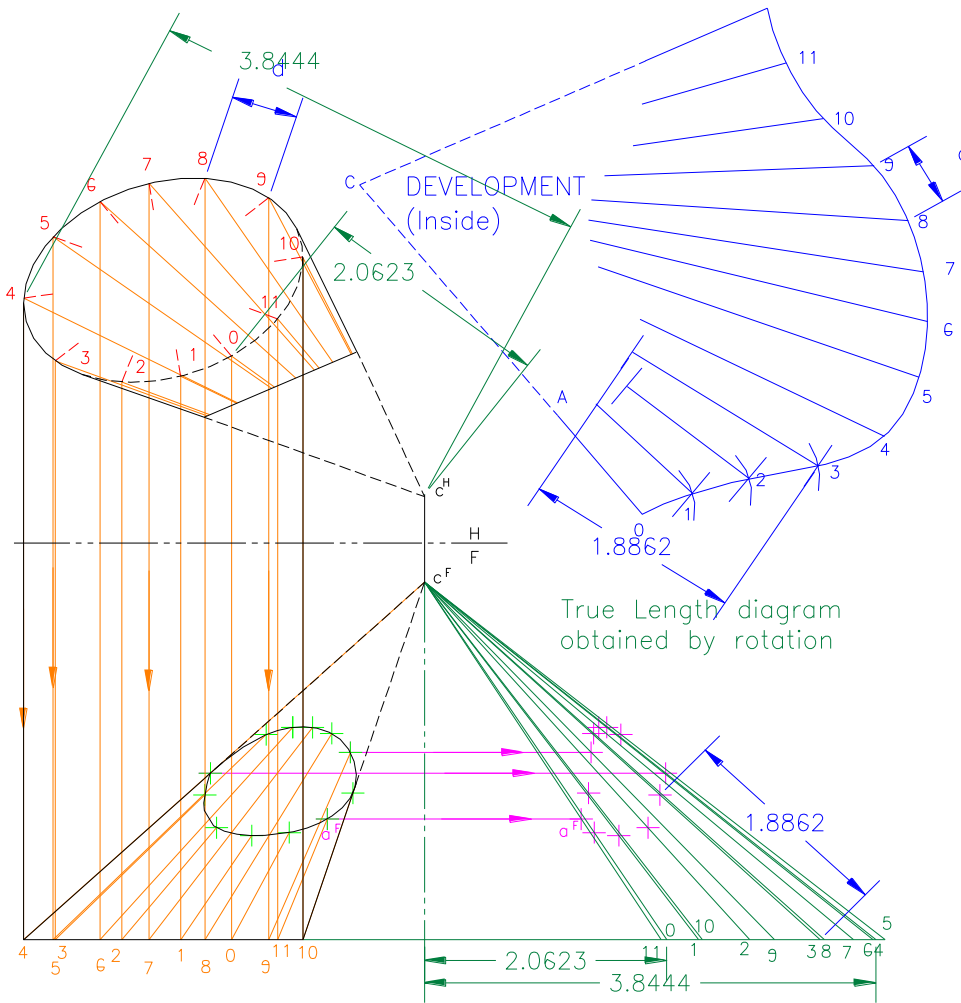

In oblique cone, the radial lines are not equal so even if the base is circular, it will not develop as a circular arc. It is hence assumed that the surface between consecutive elements is narrow enough so that approximation can be done.

The base is an ellipse and is divided into 12 equal parts and the elements are drawn in each view

The TL of the elements are drawn adjacent to FV based on the dimensions in the TV. Eg. for elements 0 and 4 shown. Repeat for all other elements as well

Project points from the FV to the TL view on the proper elements. a^F is projected onto 11V as example here. Similarly project other points.

For the development, cone appears TS in the TV hence the chordal distances can be transferred directly.

First radial line V_0 can be positioned as desired. Then a small arc with radius C_1 (TL view) is cut from Centre as C. With centre in 0 and radius as chordal distance 0-1, another arc is cut to intersect the previous one. this is the point 1 in development of the base

Similarly other points are located and a smooth curve drawn between them locates the development of the base. The angular spacing is not equal.

For the upper curve, distances of the elements from the TL view are transferred. 2,3 shown as eg.

Development of an Oblique Truncated Cone Triangulation Method

(A) DEVELOPMENTS. OBLIQUE CONE.

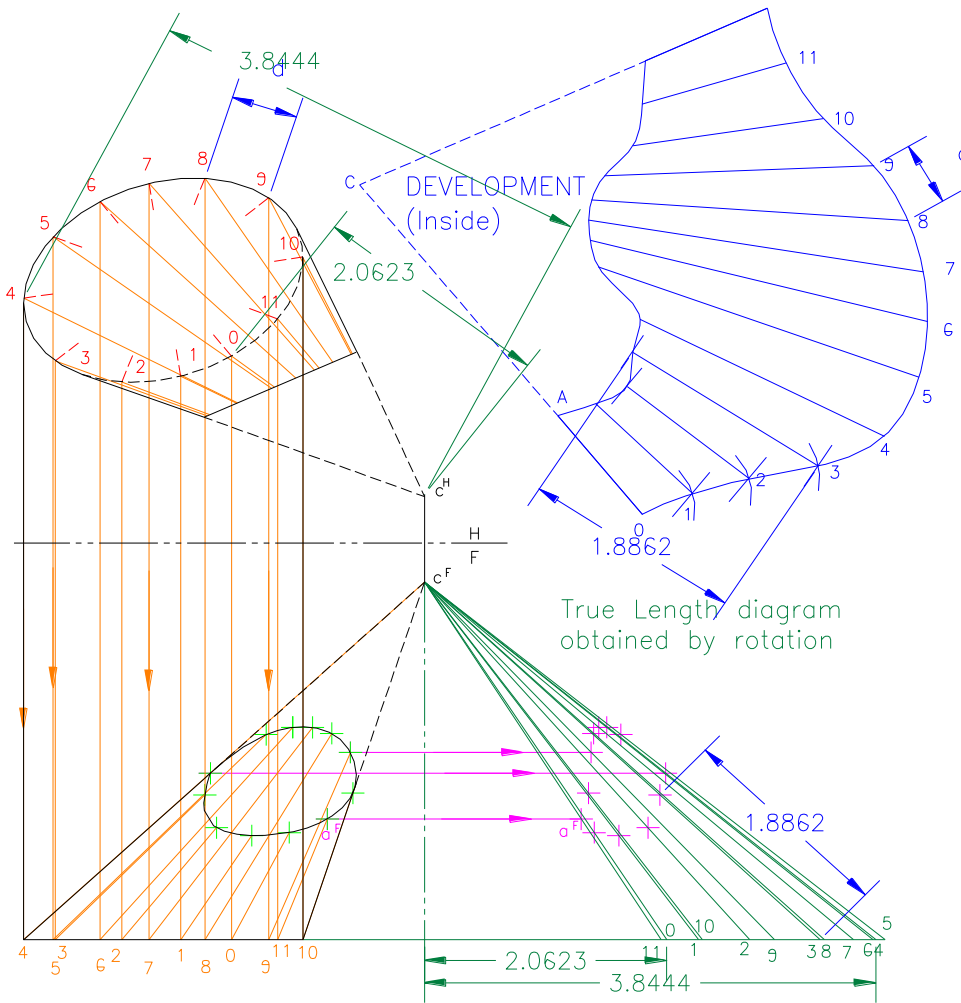

In oblique cone, the radial lines are not equal so even if the base is circular, it will not develop as a circular arc. It is hence assumed that the surface between consecutive elements is narrow enough so that approximation can be done.

The base is an ellipse and is divided into 12 equal parts and the elements are drawn in each view

The TL of the elements are drawn adjacent to FV based on the dimensions in the TV. Eg. for elements 0 and 4 shown. Repeat for all other elements as well

Project points from the FV to the TL view on the proper elements. aF is projected onto 11V as example here. Similarly project other points.

For the development, cone appears TS in the TV hence the chordal distances can be transferred directly.

First radial line $V0$ can be positioned as desired. Then a small arc with radius $C1$ (TL view) is cut from Centre as C . With centre in O and radius as chordal distance $0-1$, another arc is cut to intersect the previous one. this is the point 1 in development of the base

Similarly other points are located and a smooth curve drawn between them locates the development of the base. The angular spacing is not equal.

For the upper curve, distances of the elements from the TL view are transferred. 2,3 shown as eg.

Other points are similarly located and a smooth curve drawn between them to complete the development

Development of an Oblique Truncated Cone Triangulation Method

(A) DEVELOPMENTS. OBLIQUE CONE.

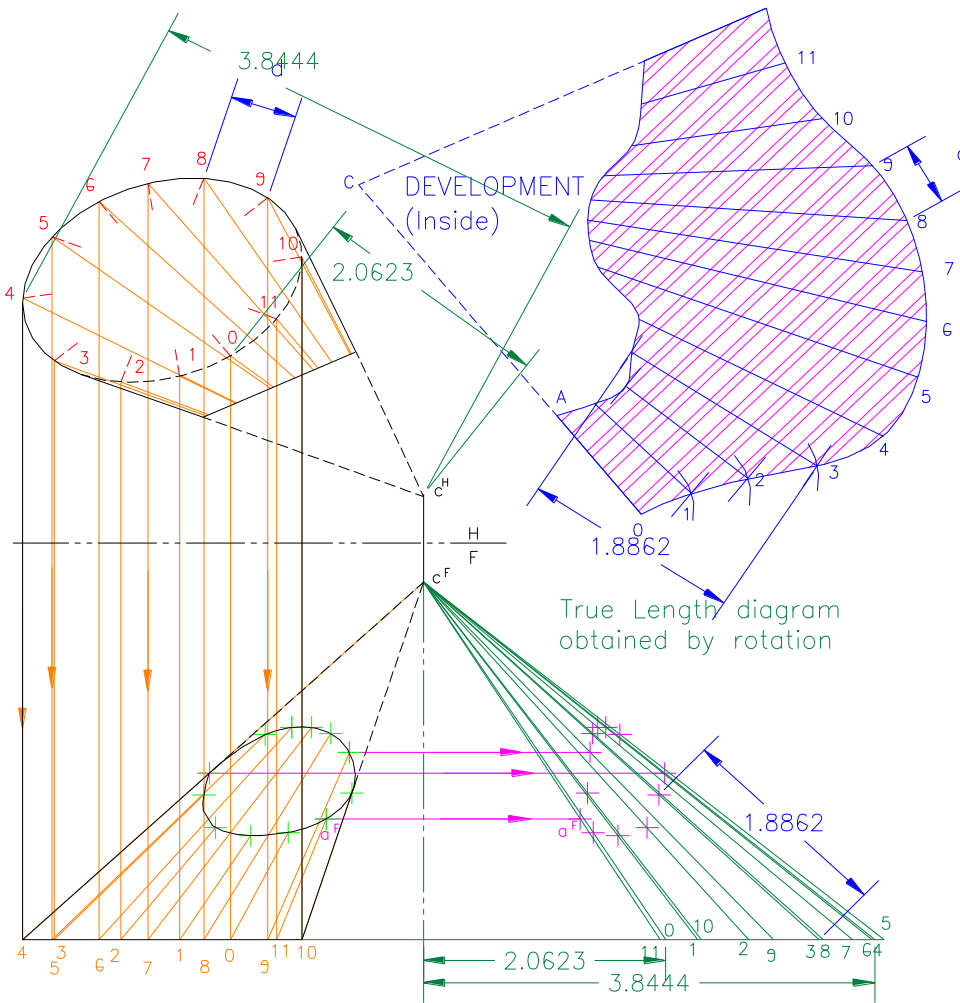

In oblique cone, the radial lines are not equal so even if the base is circular, it will not develop as a circular arc. It is hence assumed that the surface between consecutive elements is narrow enough so that approximation can be done.

The base is an ellipse and is divided into 12 equal parts and the elements are drawn in each view

The TL of the elements are drawn adjacent to FV based on the dimensions in the TV. Eg. for elements 0 and 4 shown. Repeat for all other elements as well

Project points from the FV to the TL view on the proper elements. aF is projected onto 11V as example here. Similarly project other points.

For the development, cone appears TS in the TV hence the chordal distances can be transferred directly.

First radial line V0 can be positioned as desired. Then a small arc with radius C1 (TL view) is cut from Centre as C. With centre in 0 and radius as chordal distance 0-1, another arc is cut to intersect the previous one. this is the point 1 in development of the base

Similarly other points are located and a smooth curve drawn between them locates the development of the base. The angular spacing is not equal.

For the upper curve, distances of the elements from the TL view are transferred. 2,3 shown as eg.

Other points are similarly located and a smooth curve drawn between them to complete the development

Development of Intersecting Cylinders

(A) DEVELOPMENTS. INTERSECTING CYLINDERS.

The dimensions of a cylinder development are obtained from a true-length view and from the end view of the cylinder.

The bigger cylinder is positioned horizontally, thus its end view is given in the frontal projection; obtaining the end view for the other cylinder:

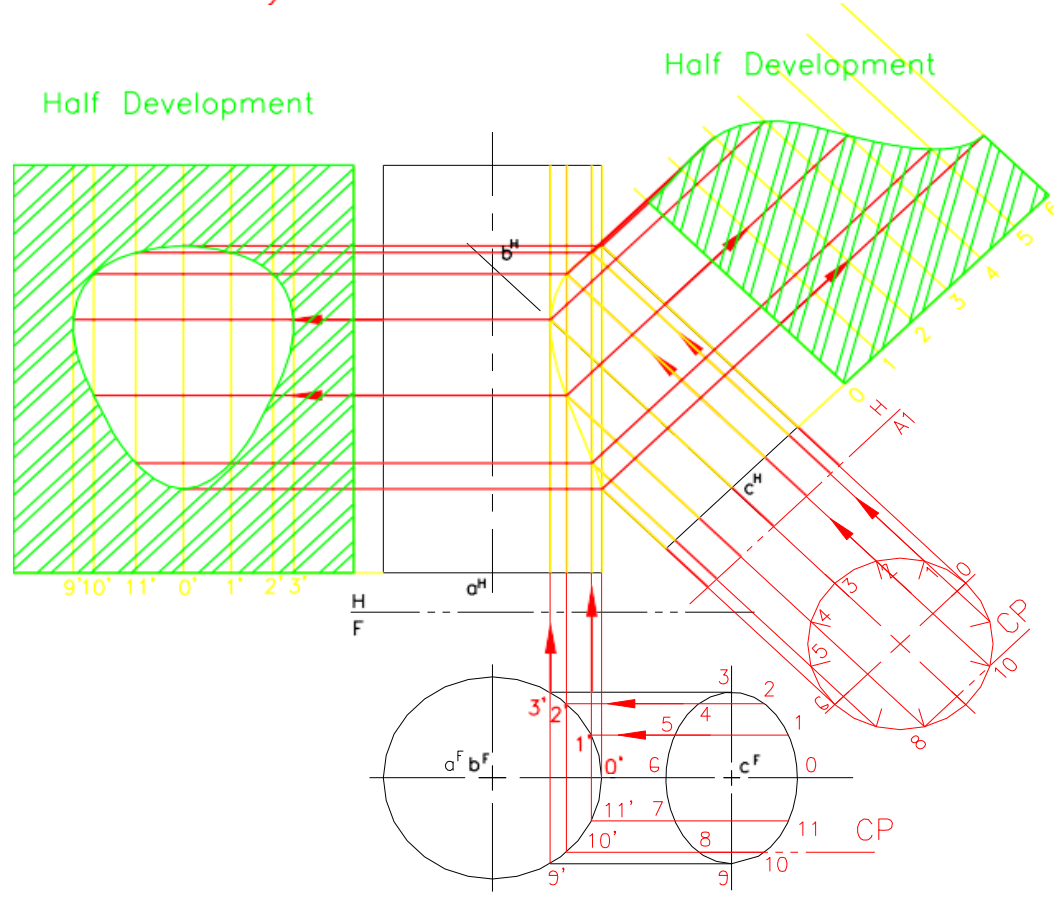

Number	Name	Date	Assignment
L07T07			

Development of Intersecting Cylinders

(A) DEVELOPMENTS. INTERSECTING CYLINDERS.

Intersecting cylinders are common in pipe connection. For large connections, can be made by cutting and welding two pipes along line of intersection. so establish line of cut on each pipe at intersection and then two cylindrical surfaces can be developed

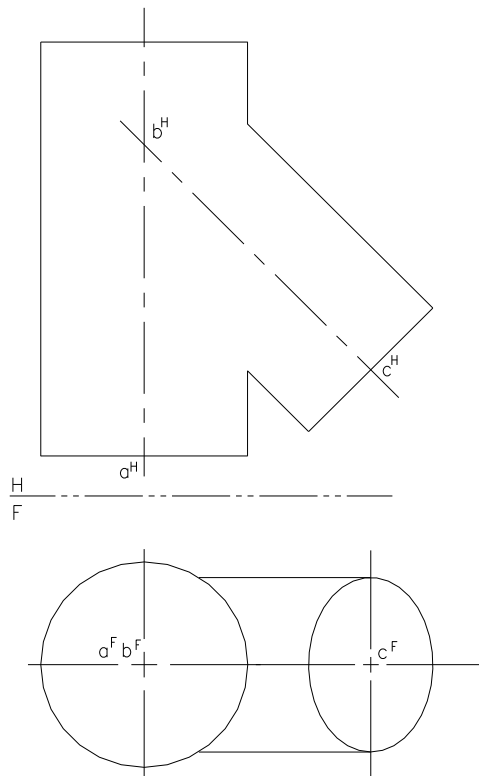

The dimensions of a cylinder development are obtained from a true-length view and from the end view of the cylinder.

Development of Intersecting Cylinders

(A) DEVELOPMENTS. INTERSECTING CYLINDERS.

Intersecting cylinders are common in pipe connection. For large connections, can be made by cutting and welding two pipes along line of intersection. so establish line of cut on each pipe at intersection and then two cylindrical surfaces can be developed

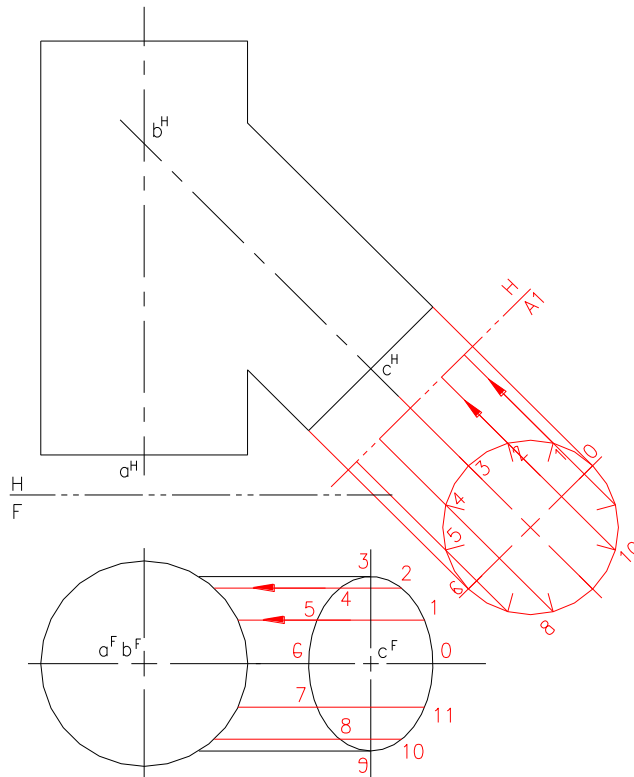

The dimensions of a cylinder development are obtained from a true-length view and from the end view of the cylinder.

The bigger cylinder is positioned horizontally, thus its end view is given in the frontal projection; obtaining the end view for the other cylinder:

Development of Intersecting Cylinders

(A) DEVELOPMENTS. INTERSECTING CYLINDERS.

Intersecting cylinders are common in pipe connection. For large connections, can be made by cutting and welding two pipes along line of intersection. so establish line of cut on each pipe at intersection and then two cylindrical surfaces can be developed

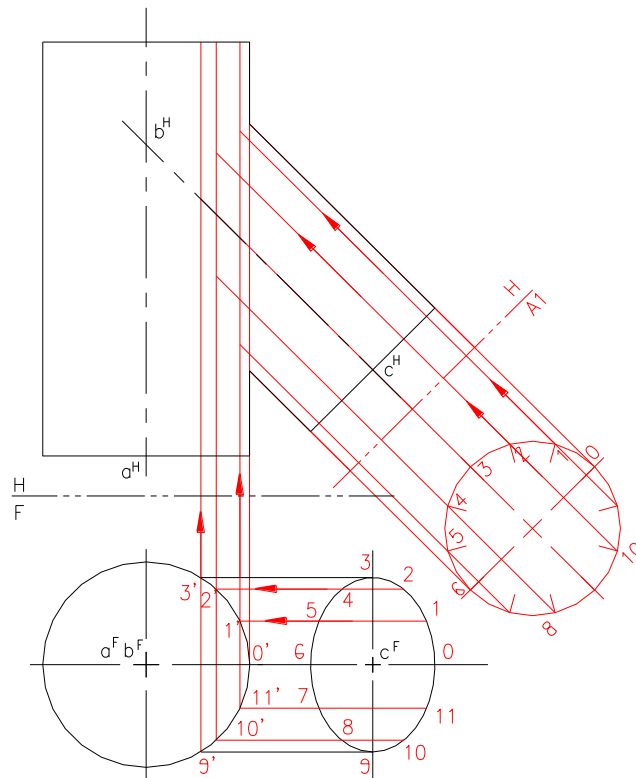

The dimensions of a cylinder development are obtained from a true-length view and from the end view of the cylinder.

The bigger cylinder is positioned horizontally, thus its end view is given in the frontal projection; obtaining the end view for the other cylinder:

Development of Intersecting Cylinders

(A) DEVELOPMENTS. INTERSECTING CYLINDERS.

Intersecting cylinders are common in pipe connection. For large connections, can be made by cutting and welding two pipes along line of intersection. so establish line of cut on each pipe at intersection and then two cylindrical surfaces can be developed

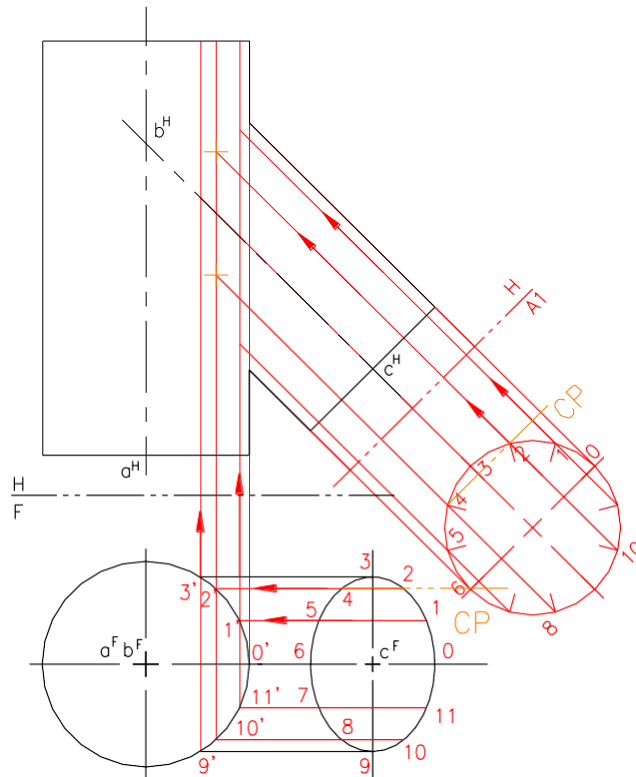

The dimensions of a cylinder development are obtained from a true-length view and from the end view of the cylinder.

The bigger cylinder is positioned horizontally, thus its end view is given in the frontal projection; obtaining the end view for the other cylinder:

For [intersection](#) lines, draw cutting planes parallel to both cylinders and find the point of intersection in the TV. Eg. 2 and 4 shown. Do for all other points and complete the intersection

Development of Intersecting Cylinders

(A) DEVELOPMENTS. INTERSECTING CYLINDERS.

Intersecting cylinders are common in pipe connection. For large connections, can be made by cutting and welding two pipes along line of intersection. so establish line of cut on each pipe at intersection and then two cylindrical surfaces can be developed

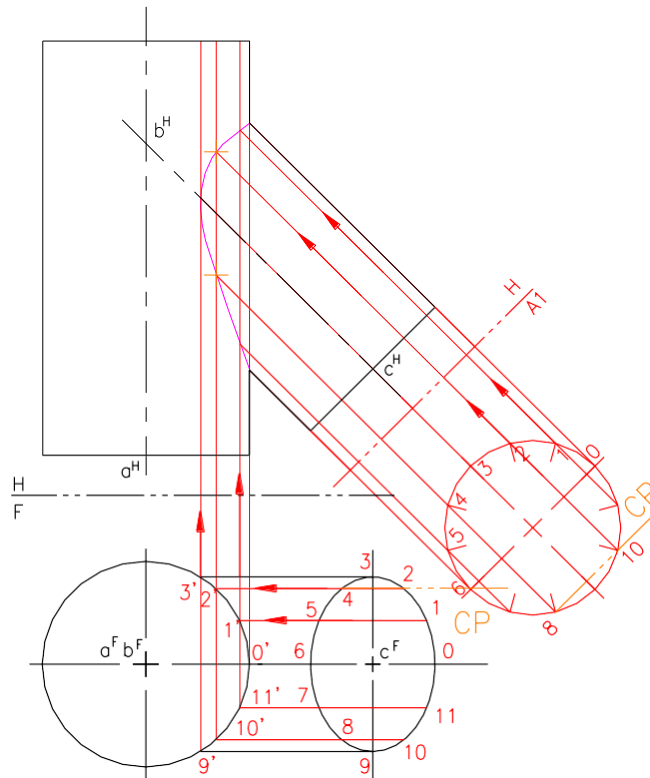

The dimensions of a cylinder development are obtained from a true-length view and from the end view of the cylinder.

The bigger cylinder is positioned horizontally, thus its end view is given in the frontal projection; obtaining the end view for the other cylinder:

For [intersection](#) lines, draw cutting planes parallel to both cylinders and find the point of intersection in the TV. Eg. 2 and 4 shown. Do for all other points and complete the intersection

Development of Intersecting Cylinders

(A) DEVELOPMENTS. INTERSECTING CYLINDERS.

Intersecting cylinders are common in pipe connection. For large connections, can be made by cutting and welding two pipes along line of intersection. so establish line of cut on each pipe at intersection and then two cylindrical surfaces can be developed

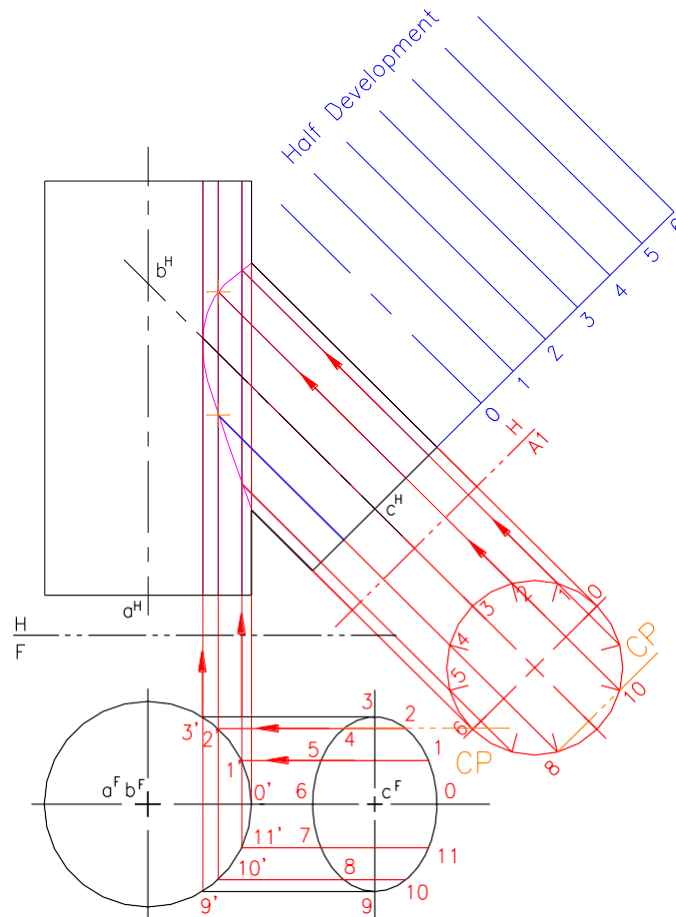

The dimensions of a cylinder development are obtained from a true-length view and from the end view of the cylinder.

The bigger cylinder is positioned horizontally, thus its end view is given in the frontal projection; obtaining the end view for the other cylinder:

For intersection lines, draw cutting planes parallel to both cylinders and find the point of intersection in the TV, Eg. 2 and 4 shown. Do for all other points and complete the intersection

For the development, both cylinders elements appear in TL in the TV. So development can be done adjacent to this view for both cylinders

For the brach cylinder the stretch out line length is taken from the EV (TS) and perpendiculars erected based on the points in EV. Since top and bottom of this cylinder is same, only half development can be done.

Development of Intersecting Cylinders

(A) DEVELOPMENTS. INTERSECTING CYLINDERS.

Intersecting cylinders are common in pipe connection. For large connections, can be made by cutting and welding two pipes along line of intersection. so establish line of cut on each pipe at intersection and then two cylindrical surfaces can be developed

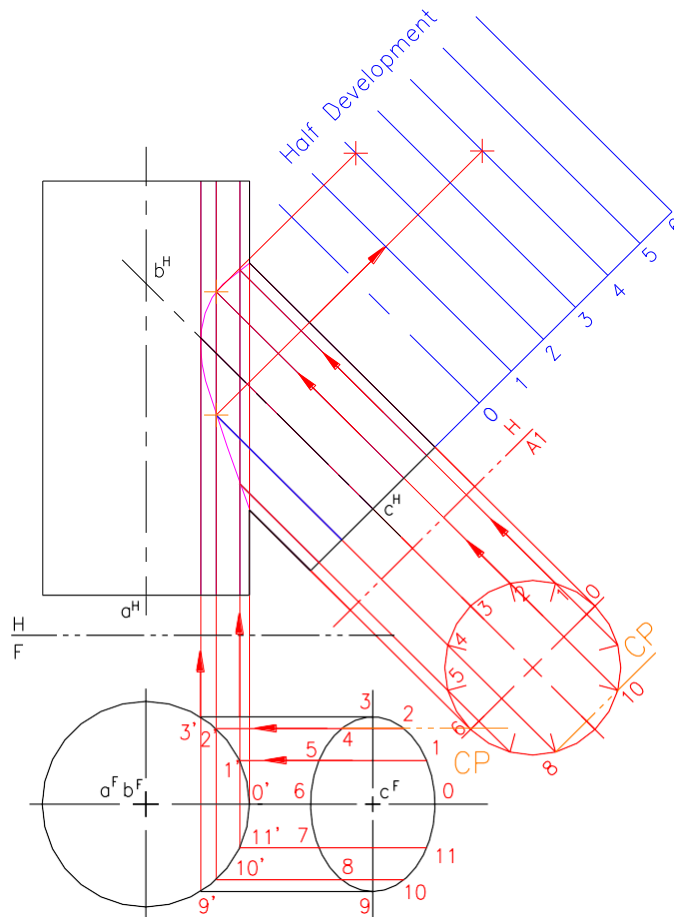

The dimensions of a cylinder development are obtained from a true-length view and from the end view of the cylinder.

The bigger cylinder is positioned horizontally, thus its end view is given in the frontal projection; obtaining the end view for the other cylinder:

For intersection lines, draw cutting planes parallel to both cylinders and find the point of intersection in the TV, Eg. 2 and 4 shown. Do for all other points and complete the intersection

For the development, both cylinders elements appear in TL in the TV. So development can be done adjacent to this view for both cylinders

For the brach cylinder the stretch out line length is taken from the EV (TS) and perpendiculars erected based on the points in EV. Since top and bottom of this cylinder is same, only half development can be done.

Project lines from intersection parallel to the stretch out line based on the points. 2 and 4 shown as eg. repeat for other 5 points

Development of Intersecting Cylinders

(A) DEVELOPMENTS. INTERSECTING CYLINDERS.

Intersecting cylinders are common in pipe connection. For large connections, can be made by cutting and welding two pipes along line of intersection. so establish line of cut on each pipe at intersection and then two cylindrical surfaces can be developed

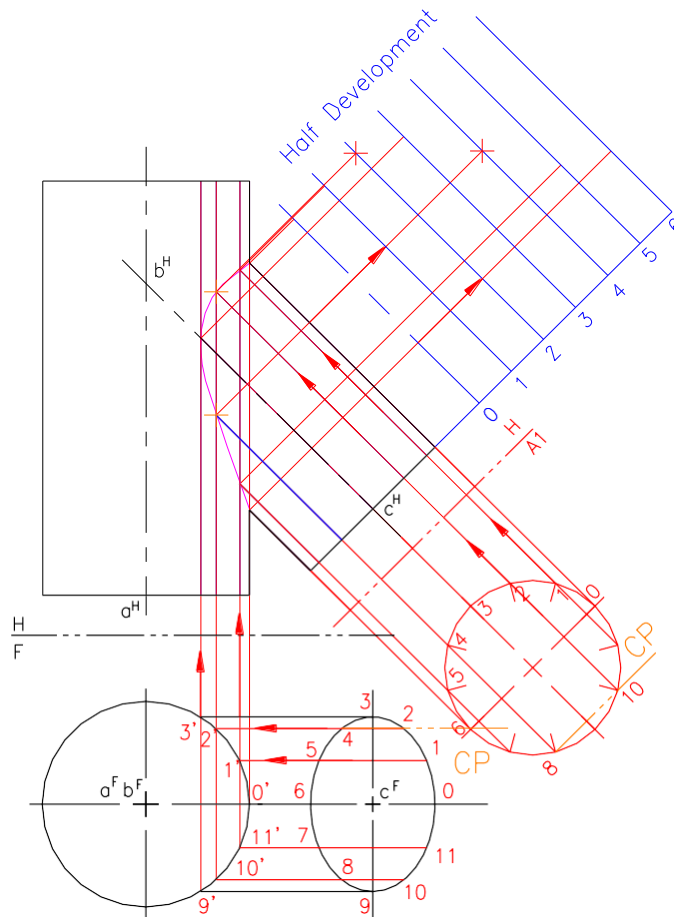

The dimensions of a cylinder development are obtained from a true-length view and from the end view of the cylinder.

The bigger cylinder is positioned horizontally, thus its end view is given in the frontal projection; obtaining the end view for the other cylinder:

For intersection lines, draw cutting planes parallel to both cylinders and find the point of intersection in the TV, Eg. 2 and 4 shown. Do for all other points and complete the intersection

For the development, both cylinders elements appear in TL in the TV. So development can be done adjacent to this view for both cylinders

For the brach cylinder the stretch out line length is taken from the EV (TS) and perpendiculars erected based on the points in EV. Since top and bottom of this cylinder is same, only half development can be done.

Project lines from intersection parallel to the stretch out line based on the points. 2 and 4 shown as eg. repeat for other 5 points

Development of Intersecting Cylinders

(A) DEVELOPMENTS. INTERSECTING CYLINDERS.

Intersecting cylinders are common in pipe connection. For large connections, can be made by cutting and welding two pipes along line of intersection. so establish line of cut on each pipe at intersection and then two cylindrical surfaces can be developed

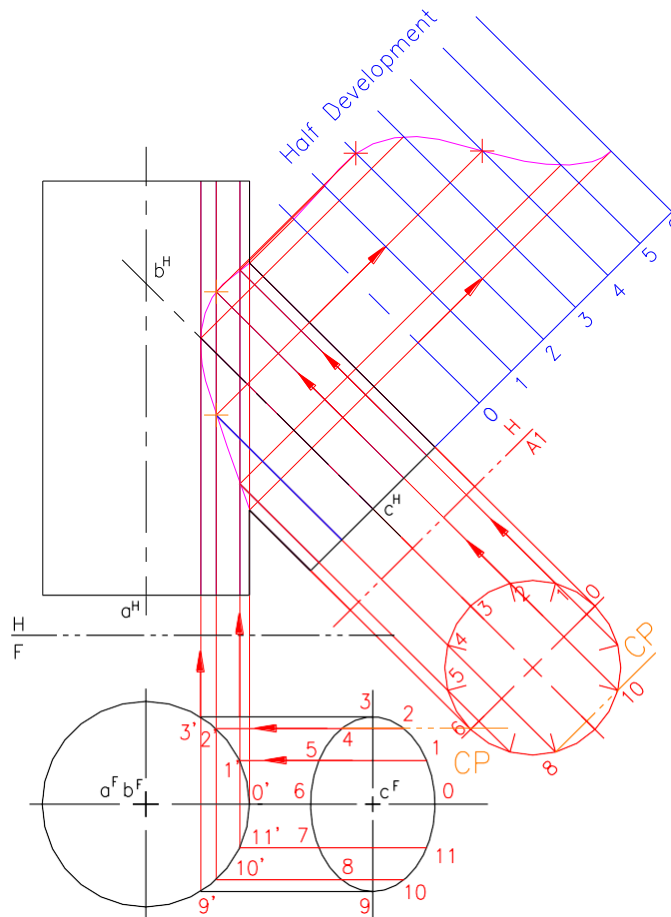

The dimensions of a cylinder development are obtained from a true-length view and from the end view of the cylinder.

The bigger cylinder is positioned horizontally, thus its end view is given in the frontal projection; obtaining the end view for the other cylinder:

For intersection lines, draw cutting planes parallel to both cylinders and find the point of intersection in the TV, Eg. 2 and 4 shown. Do for all other points and complete the intersection

For the development, both cylinders elements appear in TL in the TV. So development can be done adjacent to this view for both cylinders

For the brach cylinder the stretch out line length is taken from the EV (TS) and perpendiculars erected based on the points in EV. Since top and bottom of this cylinder is same, only half development can be done.

Project lines from intersection parallel to the stretch out line based on the points. 2 and 4 shown as eg. repeat for other 5 points

Complete the development with a smooth curve based on the points obtained

Development of Intersecting Cylinders

(A) DEVELOPMENTS. INTERSECTING CYLINDERS.

Intersecting cylinders are common in pipe connection. For large connections, can be made by cutting and welding two pipes along line of intersection. so establish line of cut on each pipe at intersection and then two cylindrical surfaces can be developed

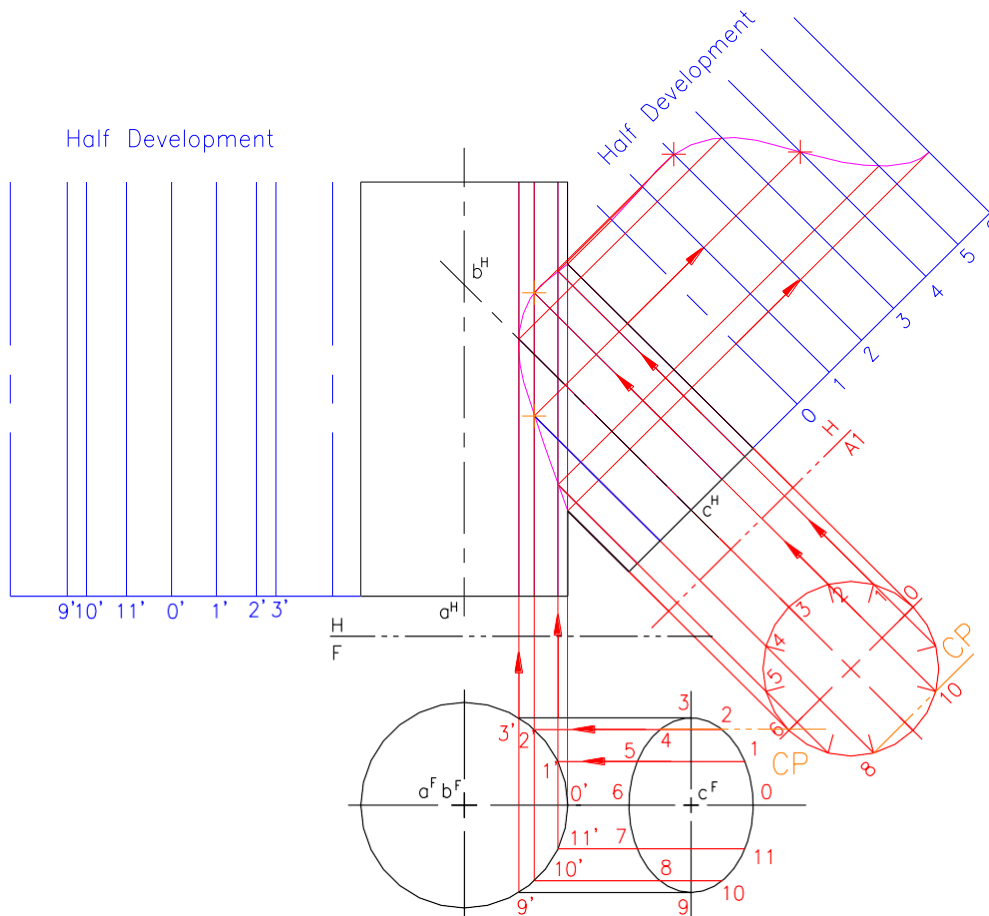

The dimensions of a cylinder development are obtained from a true-length view and from the end view of the cylinder.

The bigger cylinder is positioned horizontally, thus its end view is given in the frontal projection; obtaining the end view for the other cylinder:

For intersection lines, draw cutting planes parallel to both cylinders and find the point of intersection in the TV. Eg. 2 and 4 shown. Do for all other points and complete the intersection

For the development, both cylinders elements appear in TL in the TV. So development can be done adjacent to this view for both cylinders

For the brach cylinder the stretch out line length is taken from the EV (TS) and perpendiculars erected based on the points in EV. Since top and bottom of this cylinder is same, only half development can be done.

Project lines from intersection parallel to the stretch out line based on the points. 2 and 4 shown as eg. repeat for other 5 points

Complete the development with a smooth curve based on the points obtained

For the cylinder with axis ab, the stretch out line length is taken from the FV. and half development is done based on the right side where the intersection happens

Development of Intersecting Cylinders

(A) DEVELOPMENTS. INTERSECTING CYLINDERS.

Intersecting cylinders are common in pipe connection. For large connections, can be made by cutting and welding two pipes along line of intersection. so establish line of cut on each pipe at intersection and then two cylindrical surfaces can be developed

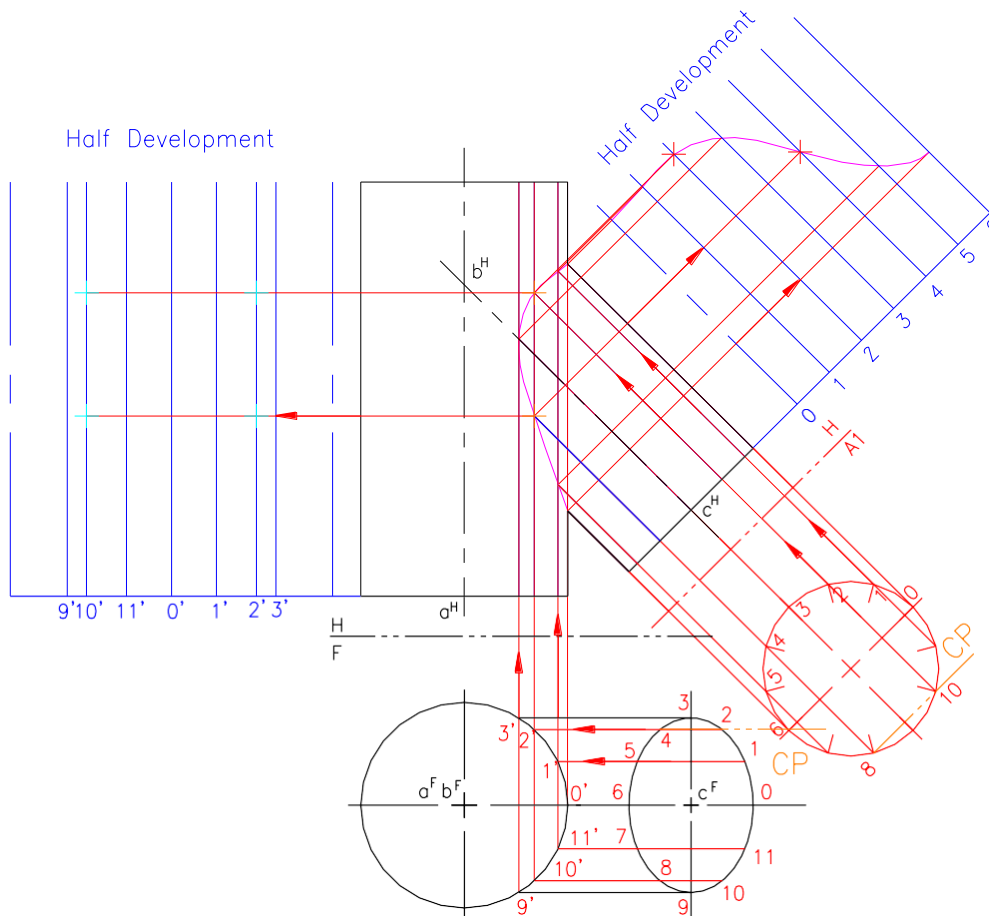

The dimensions of a cylinder development are obtained from a true-length view and from the end view of the cylinder.

The bigger cylinder is positioned horizontally, thus its end view is given in the frontal projection; obtaining the end view for the other cylinder:

For intersection lines, draw cutting planes parallel to both cylinders and find the point of intersection in the TV, Eg. 2 and 4 shown. Do for all other points and complete the intersection

For the development, both cylinders elements appear in TL in the TV. So development can be done adjacent to this view for both cylinders

For the brach cylinder the stretch out line length is taken from the EV (TS) and perpendiculars erected based on the points in EV. Since top and bottom of this cylinder is same, only half development can be done.

Project lines from intersection parallel to the stretch out line based on the points. 2 and 4 shown as eg. repeat for other 5 points

Complete the development with a smooth curve based on the points obtained

For the cylinder with axis ab , the stretch out line length is taken from the FV, and half development is done based on the right side where the intersection happens

Project lines from intersection parallel to the stretch out line based on the points. 2 and 10 shown as eg. repeat for other points

Development of Intersecting Cylinders

(A) DEVELOPMENTS. INTERSECTING CYLINDERS.

Intersecting cylinders are common in pipe connection. For large connections, can be made by cutting and welding two pipes along line of intersection. so establish line of cut on each pipe at intersection and then two cylindrical surfaces can be developed

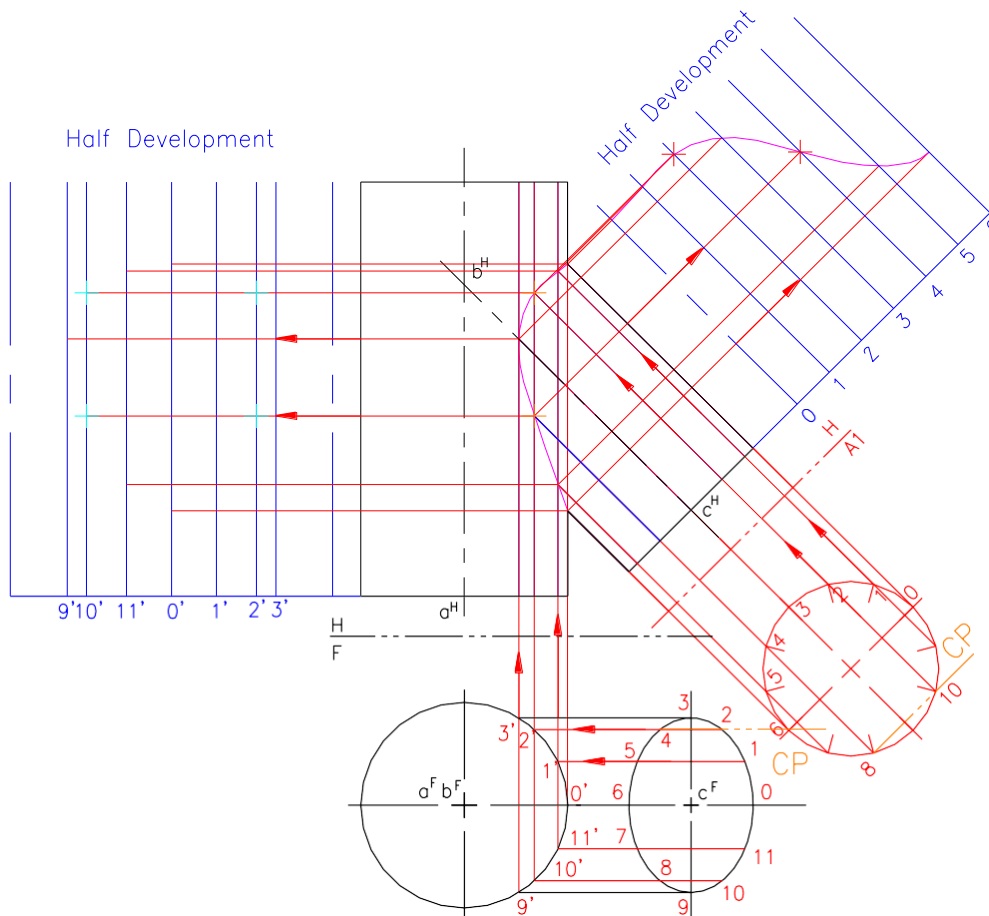

The dimensions of a cylinder development are obtained from a true-length view and from the end view of the cylinder.

The bigger cylinder is positioned horizontally, thus its end view is given in the frontal projection; obtaining the end view for the other cylinder:

For intersection lines, draw cutting planes parallel to both cylinders and find the point of intersection in the TV, Eg. 2 and 4 shown. Do for all other points and complete the intersection

For the development, both cylinders elements appear in TL in the TV. So development can be done adjacent to this view for both cylinders

For the brach cylinder the stretch out line length is taken from the EV (TS) and perpendiculars erected based on the points in EV. Since top and bottom of this cylinder is same, only half development can be done.

Project lines from intersection parallel to the stretch out line based on the points. 2 and 4 shown as eg. repeat for other 5 points

Complete the development with a smooth curve based on the points obtained

For the cylinder with axis ab , the stretch out line length is taken from the FV, and half development is done based on the right side where the intersection happens

Project lines from intersection parallel to the stretch out line based on the points. 2 and 10 shown as eg. repeat for other points

Development of Intersecting Cylinders

(A) DEVELOPMENTS. INTERSECTING CYLINDERS.

Intersecting cylinders are common in pipe connection. For large connections, can be made by cutting and welding two pipes along line of intersection, so establish line of cut on each pipe at intersection and then two cylindrical surfaces can be developed

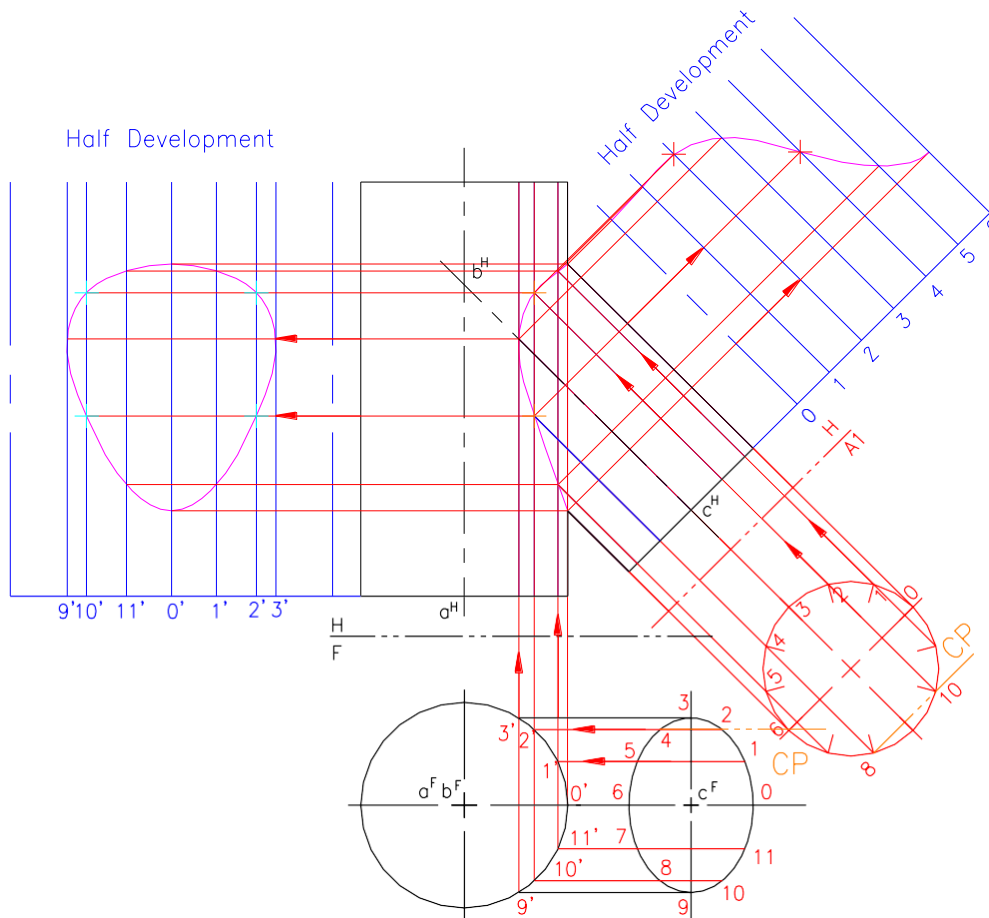

The dimensions of a cylinder development are obtained from a true-length view and from the end view of the cylinder.

The bigger cylinder is positioned horizontally, thus its end view is given in the frontal projection; obtaining the end view for the other cylinder:

For intersection lines, draw cutting planes parallel to both cylinders and find the point of intersection in the TV, Eg. 2 and 4 shown. Do for all other points and complete the intersection

For the development, both cylinders elements appear in TL in the TV. So development can be done adjacent to this view for both cylinders

For the brach cylinder the stretch out line length is taken from the EV (TS) and perpendiculars erected based on the points in EV. Since top and bottom of this cylinder is same, only half development can be done.

Project lines from intersection parallel to the stretch out line based on the points. 2 and 4 shown as eg. repeat for other 5 points

Complete the development with a smooth curve based on the points obtained

For the cylinder with axis ab, the stretch out line length is taken from the FV, and half development is done based on the right side where the intersection happens

Project lines from intersection parallel to the stretch out line based on the points. 2 and 10 shown as eg. repeat for other points

Complete the development with a smooth curve based on the points obtained

Development of Intersecting Cylinders

(A) DEVELOPMENTS. INTERSECTING CYLINDERS.

Intersecting cylinders are common in pipe connection. For large connections, can be made by cutting and welding two pipes along line of intersection. so establish line of cut on each pipe at intersection and then two cylindrical surfaces can be developed

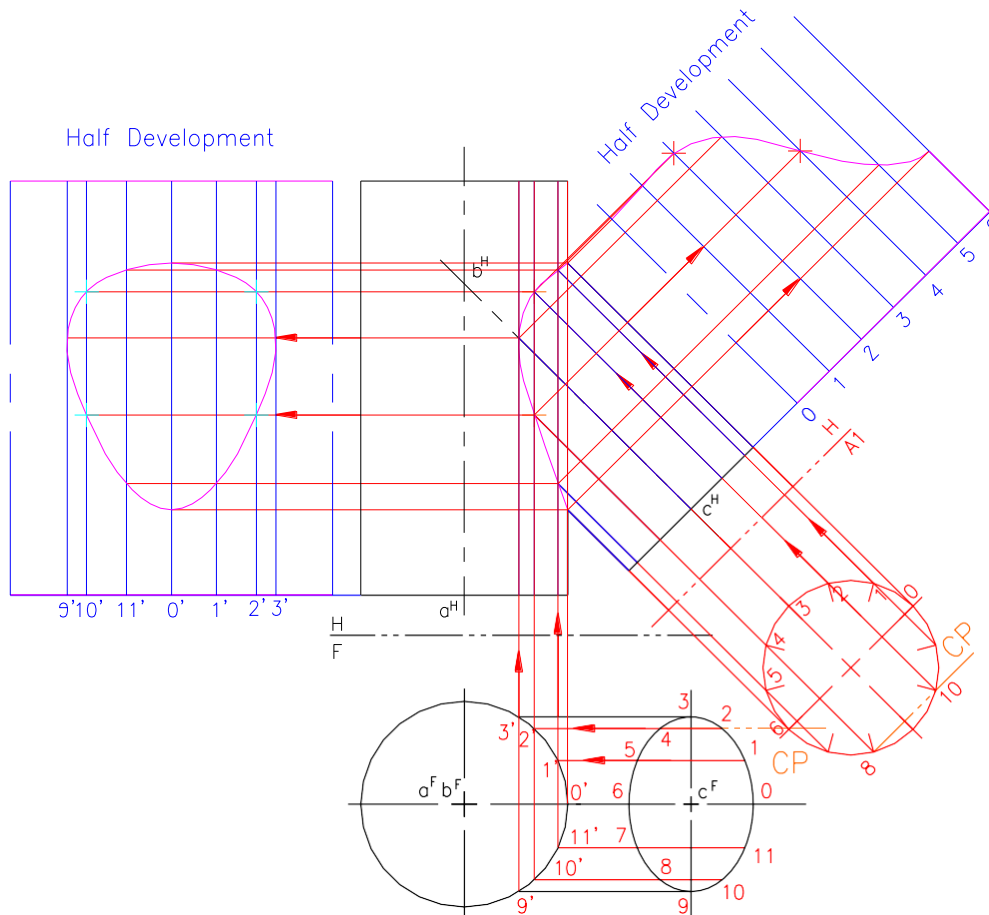

The dimensions of a cylinder development are obtained from a true-length view and from the end view of the cylinder.

The bigger cylinder is positioned horizontally, thus its end view is given in the frontal projection; obtaining the end view for the other cylinder:

For intersection lines, draw cutting planes parallel to both cylinders and find the point of intersection in the TV. Eg. 2 and 4 shown. Do for all other points and complete the intersection

For the development, both cylinders elements appear in TL in the TV. So development can be done adjacent to this view for both cylinders

For the brach cylinder the stretch out line length is taken from the EV (TS) and perpendiculars erected based on the points in EV. Since top and bottom of this cylinder is same, only half development can be done.

Project lines from intersection parallel to the stretch out line based on the points. 2 and 4 shown as eg. repeat for other 5 points

Complete the development with a smooth curve based on the points obtained

For the cylinder with axis ab , the stretch out line length is taken from the FV. and half development is done based on the right side where the intersection happens

Project lines from intersection parallel to the stretch out line based on the points. 2 and 10 shown as eg. repeat for other points

Complete the development with a smooth curve based on the points obtained

Triangulation Method

Development of Transition Parts

- Since the connecting surface is neither a pyramid or a prism previous methods of development cannot be employed here.
- In such cases the various plane surfaces can be divided into triangular areas and each triangle can be laid down in the development as soon as the TL of each of its sides has been determined.

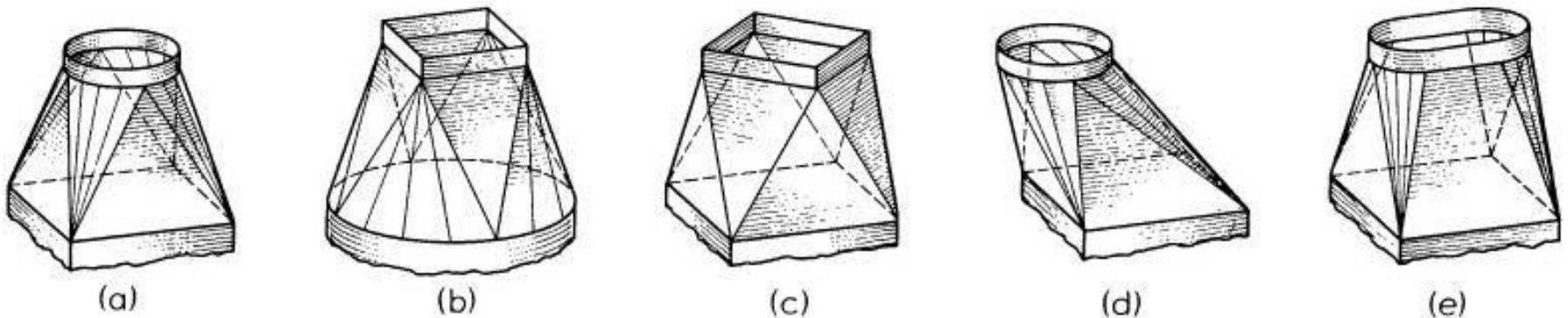

Development of Transition Parts

(A) DEVELOPMENTS. TRANSITION PIECES.

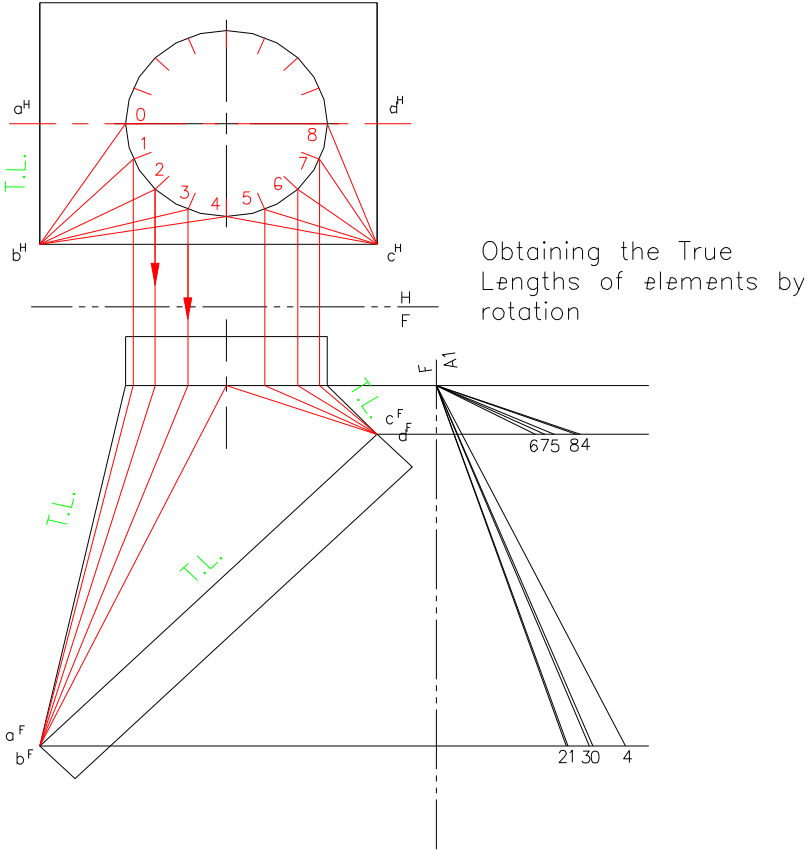

HALF DEVELOPMENT

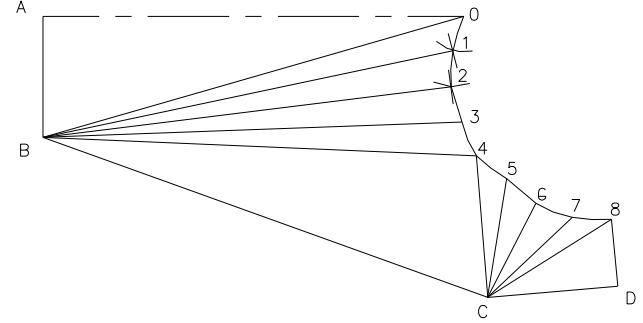

Number	Name	Date	Assignment
L07T08			

Number	Name	Date	Assignment
L07T08			

Development of Transition Parts

(A) DEVELOPMENTS. TRANSITION PIECES.

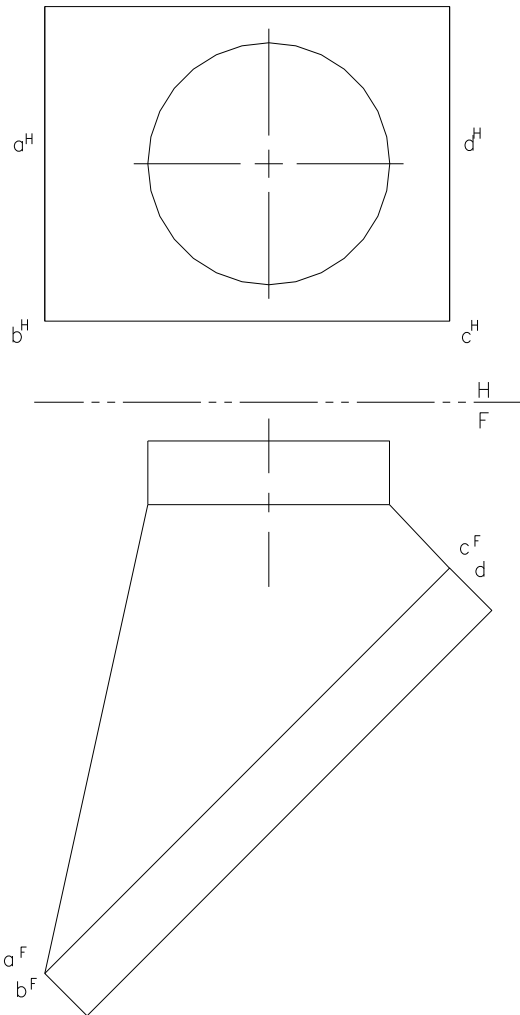

Develop Transition piece connecting circular pipe to a rectangular duct

Development of Transition Parts

(A) DEVELOPMENTS. TRANSITION PIECES.

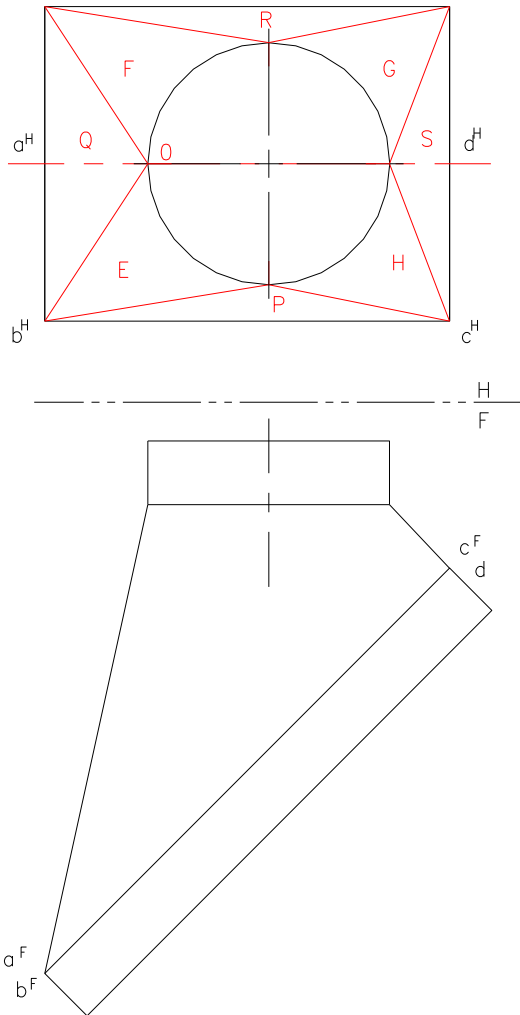

Develop Transition piece connecting circular pipe to a rectangular duct

The connecting piece consists of four triangular planes P,Q,R,S and four partial oblique cones E,F,G,H.

Each triangular piece has its base on the rectangular opening and its vertex on the circle. Each oblique cone has its vertex on the corner of rectangular opening and its base on the quarter of the circular opening.

By using similar techniques for planes, cones and cylinders, this piece and other similar pieces connecting two dissimilar shapes can be developed.

Development of Transition Parts

(A) DEVELOPMENTS. TRANSITION PIECES.

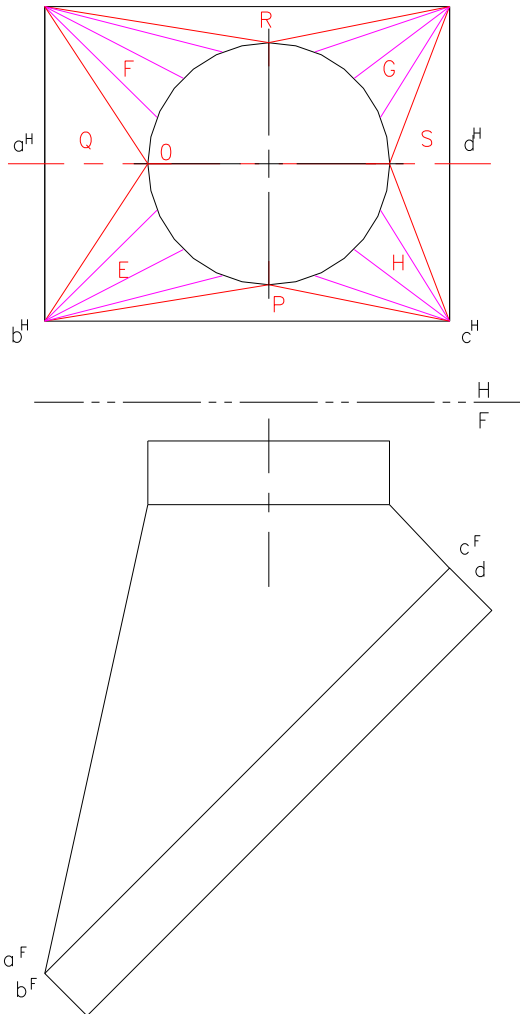

Develop Transition piece connecting circular pipe to a rectangular duct

The connecting piece consists of four triangular planes P,Q,R,S and four partial oblique cones E,F,G,H.

Each triangular piece has its base on the rectangular opening and its vertex on the circle. Each oblique cone has its vertex on the corner of rectangular opening and its base on the quarter of the circular opening.

By using similar techniques for planes, cones and cylinders, this piece and other similar pieces connecting two dissimilar shapes can be developed.

Since the surface is symmetrical based on centreline a d, only the front half of the development is enough to show the details.

Development of Transition Parts

(A) DEVELOPMENTS. TRANSITION PIECES.

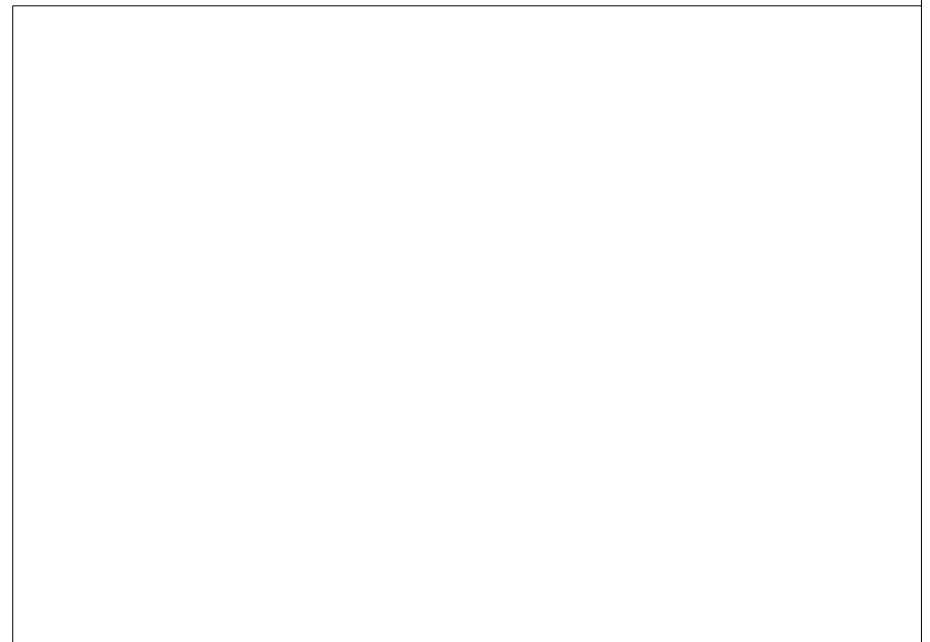
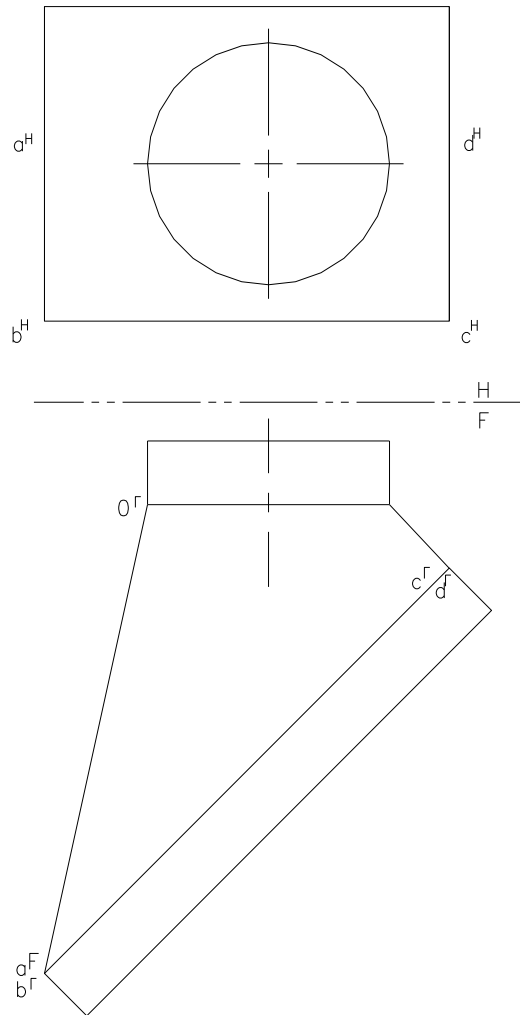

Development of Transition Parts

(A) DEVELOPMENTS. TRANSITION PIECES.

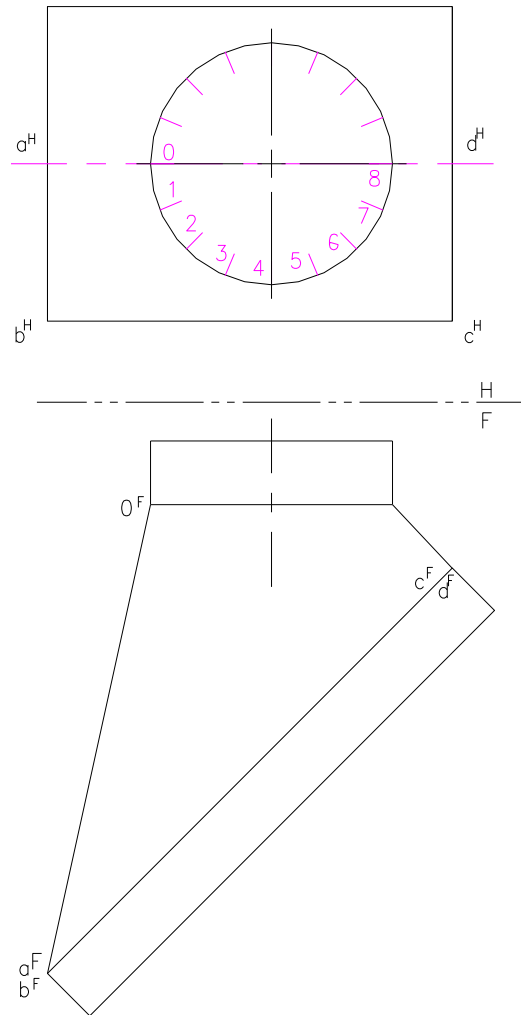

Circle is divided into 16 equal parts, only front part considered for development (Symmetry)

Development of Transition Parts

(A) DEVELOPMENTS. TRANSITION PIECES.

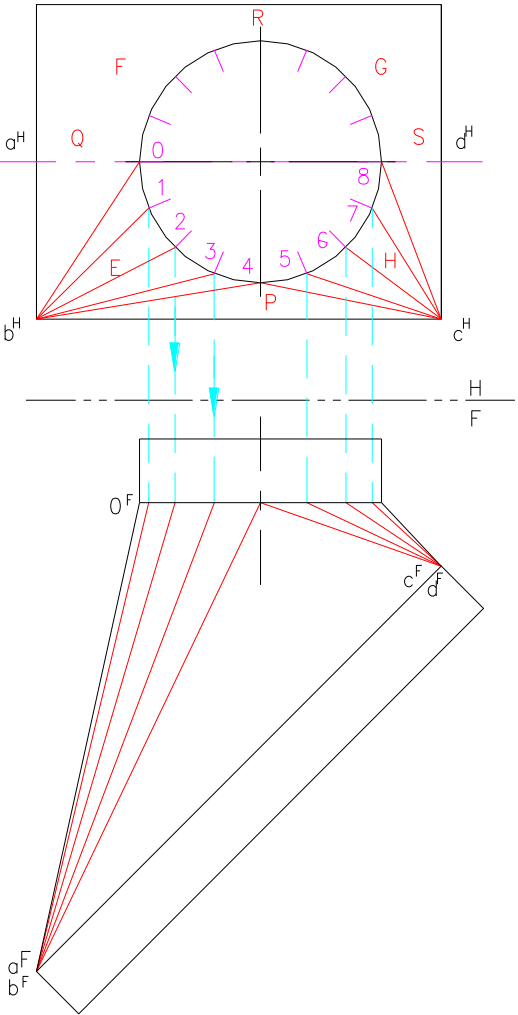

Circle is divided into 16 equal parts, only front part considered for development (Symmetry)
 The cone elements are drawn in both views using the points

Development of Transition Parts

(A) DEVELOPMENTS. TRANSITION PIECES.

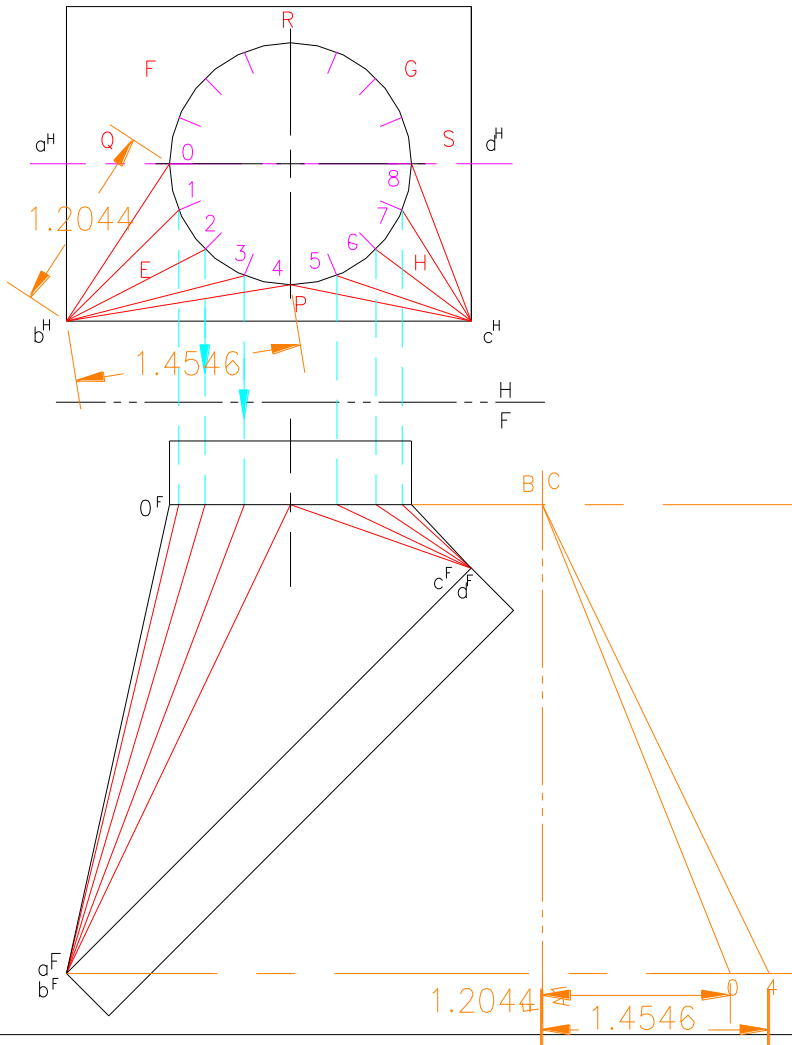

Circle is divided into 16 equal parts, only front part considered for development (Symmetry)

The cone elements are drawn in both views using the points

Obtain TL of elements in cone E by rotation. distances from axis FA1 taken from TV. 0 and 4 shown as eg. repeat for other points as well

Development of Transition Parts

(A) DEVELOPMENTS. TRANSITION PIECES.

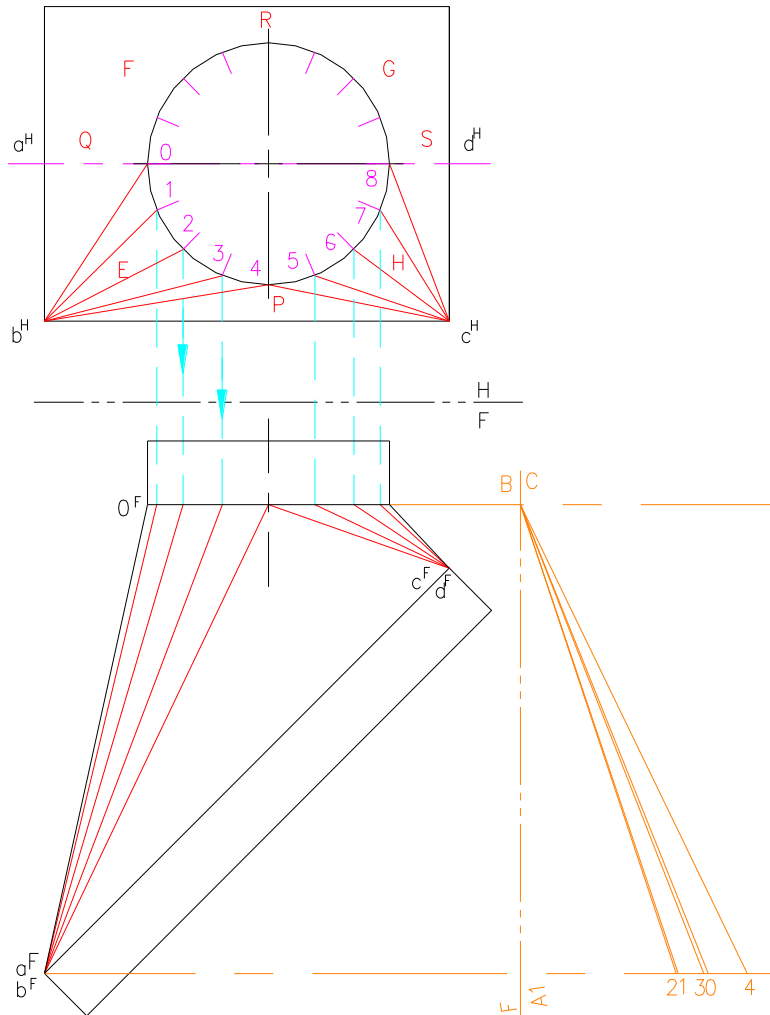

Circle is divided into 16 equal parts, only front part considered for development (Symmetry)

The cone elements are drawn in both views using the points

Obtain TL of elements in cone E by rotation. distances from axis FA1 taken from TV. 0 and 4 shown as eg. repeat for other points as well

Development of Transition Parts

(A) DEVELOPMENTS. TRANSITION PIECES.

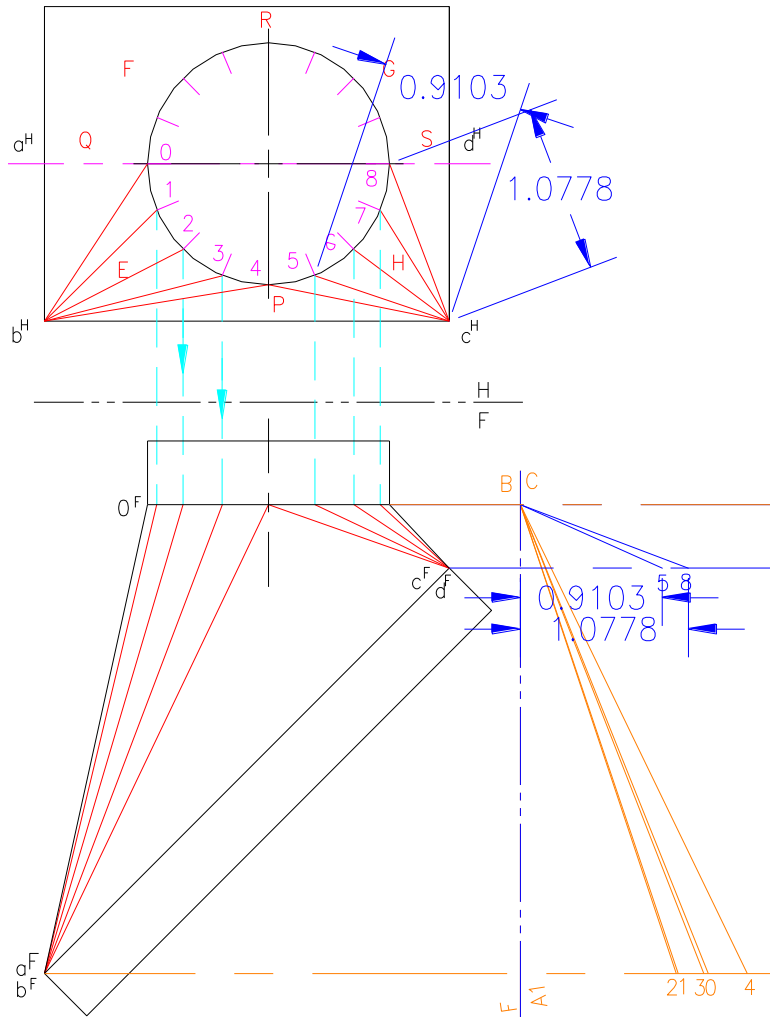

Circle is divided into 16 equal parts, only front part considered for development (Symmetry)

The cone elements are drawn in both views using the points

Obtain TL of elements in cone E by rotation. distances from axis FA1 taken from TV. 0 and 4 shown as eg. repeat for other points as well

Repeat the same for cone H. 5 & 8 shown as eg.

Development of Transition Parts

(A) DEVELOPMENTS. TRANSITION PIECES.

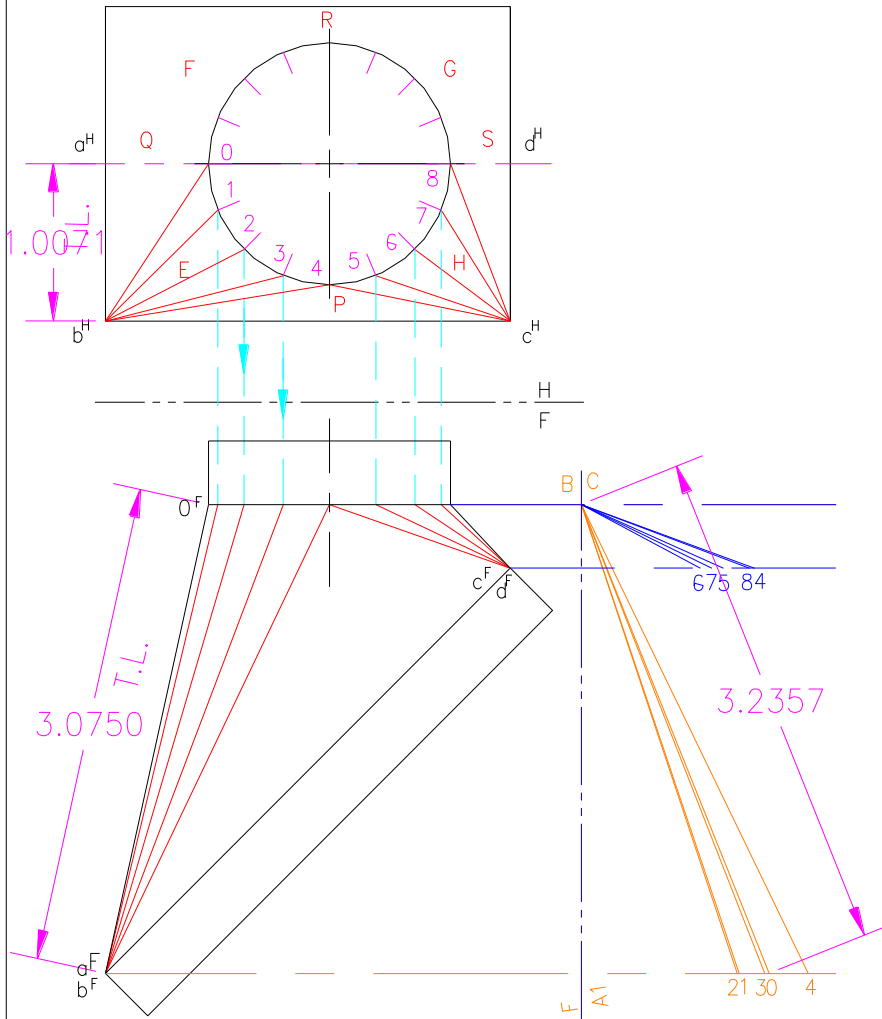

Circle is divided into 16 equal parts, only front part considered for development (Symmetry)

The cone elements are drawn in both views using the points

Obtain TL of elements in cone E by rotation. distances from axis FA1 taken from TV. 0 and 4 shown as eg. repeat for other points as well

Repeat the same for cone H. 5 & 8 shown as eg.

Half triangle (Q) ABO is developed using TL of AB from TV, TL of AO from FV and TL of BO from the TL view

Development of Transition Parts

(A) DEVELOPMENTS. TRANSITION PIECES.

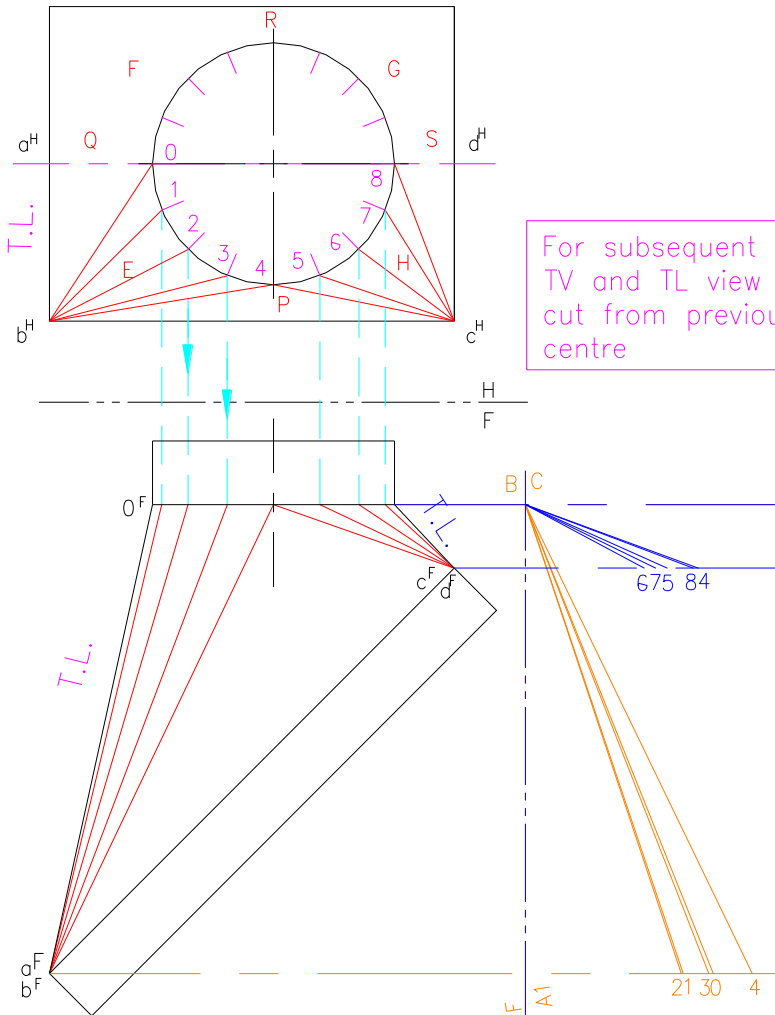

For subsequent points, distance from TV and TL view are taken and arcs cut from previous point and B as centre

HALF DEVELOPMENT

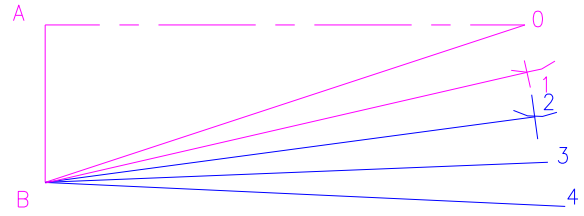

Circle is divided into 16 equal parts, only front part considered for development (Symmetry)
 The cone elements are drawn in both views using the points
 Obtain TL of elements in cone E by rotation. distances from axis FA1 taken from TV. 0 and 4 shown as eg. repeat for other points as well
 Repeat the same for cone H. 5 & 8 shown as eg.
 Half triangle (Q) ABO is developed using TL of AB from TV, TL of AO from FV and TL of BO from the TL view

Development of Transition Parts

(A) DEVELOPMENTS. TRANSITION PIECES.

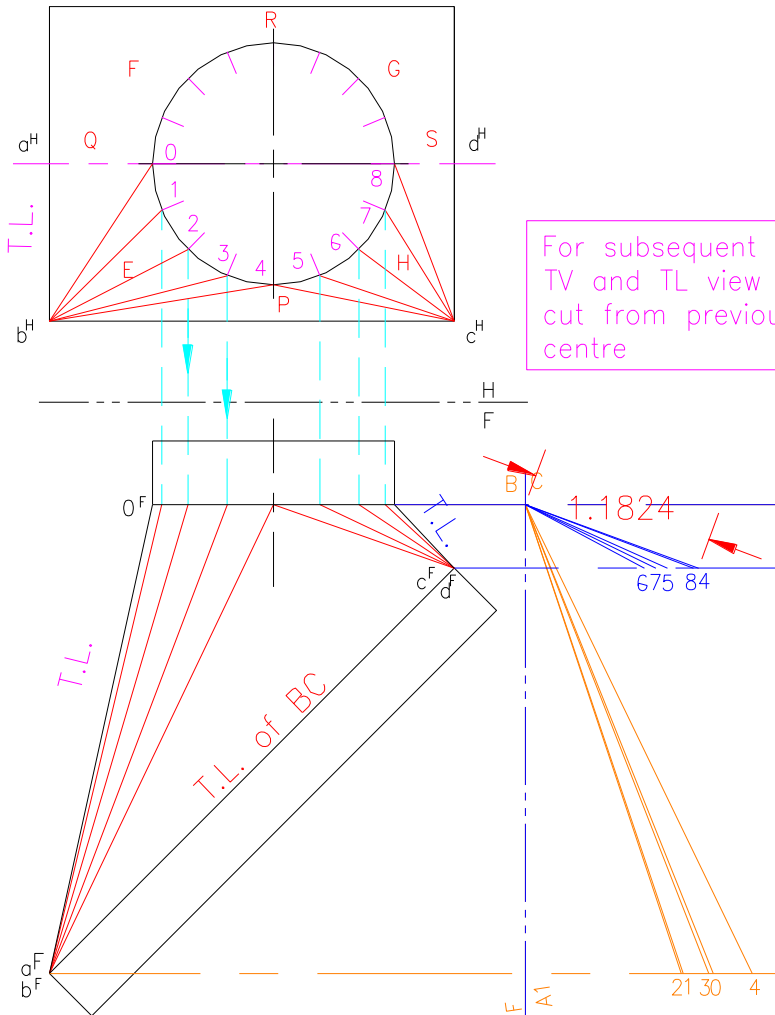

For subsequent points, distance from TV and TL view are taken and arcs cut from previous point and B as centre

HALF DEVELOPMENT

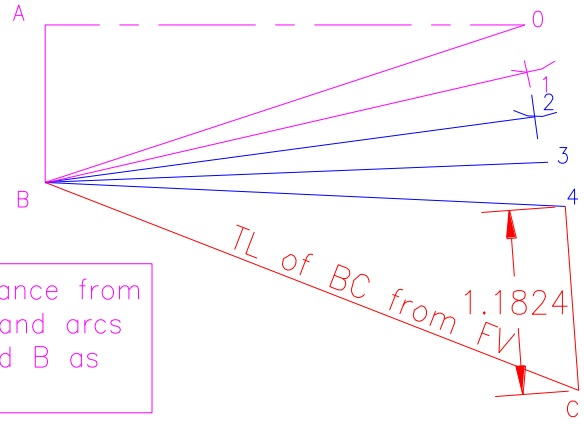

Circle is divided into 16 equal parts, only front part considered for development (Symmetry)

The cone elements are drawn in both views using the points

Obtain TL of elements in cone E by rotation. distances from axis FA1 taken from TV. 0 and 4 shown as eg. repeat for other points as well

Repeat the same for cone H. 5 & 8 shown as eg.

Half triangle (Q) ABO is developed using TL of AB from TV, TL of AO from FV and TL of BO from the TL view

For triangle (P) B4C, C is located with arcs from centres of B and 4 and distances

Development of Transition Parts

(A) DEVELOPMENTS. TRANSITION PIECES.

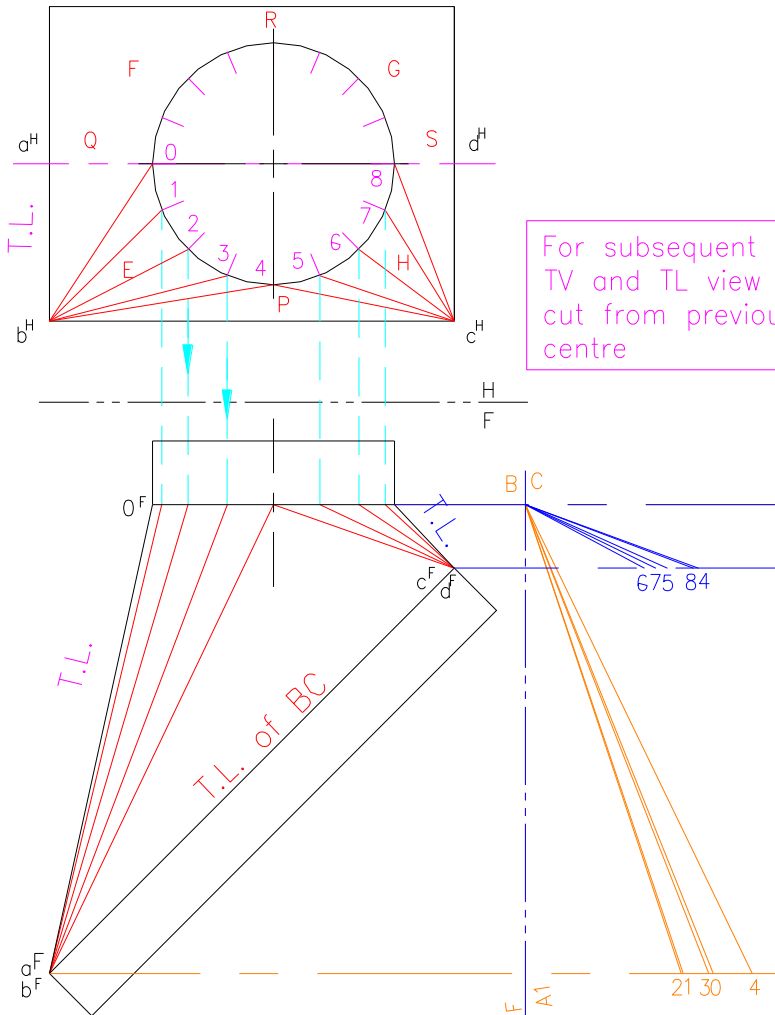

HALF DEVELOPMENT

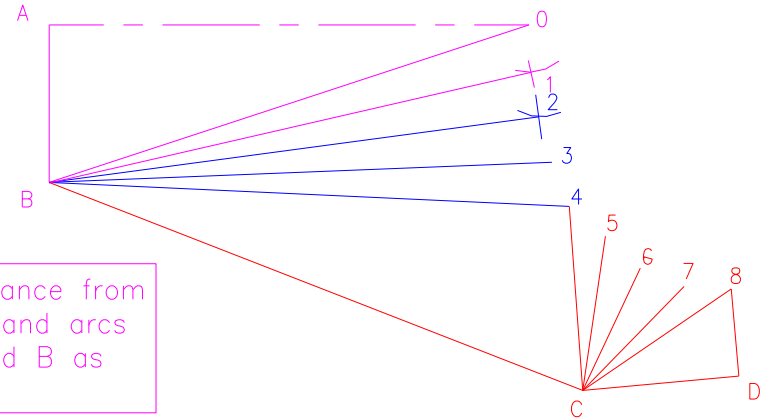

For subsequent points, distance from TV and TL view are taken and arcs cut from previous point and B as centre

Circle is divided into 16 equal parts, only front part considered for development (Symmetry)

The cone elements are drawn in both views using the points

Obtain TL of elements in cone E by rotation. distances from axis FA_1 taken from TV. 0 and 4 shown as eg. repeat for other points as well

Repeat the same for cone H. 5 & 8 shown as eg.

Half triangle (Q) ABO is developed using TL of AB from TV, TL of AO from FV and TL of BO from the TL view

For triangle (P) B_4C , C is located with arcs from centres of B and 4 and distances

For subsequent points, distance from TV and TL view are taken and arcs cut from previous point and C as centre

Development of Transition Parts

(A) DEVELOPMENTS. TRANSITION PIECES.

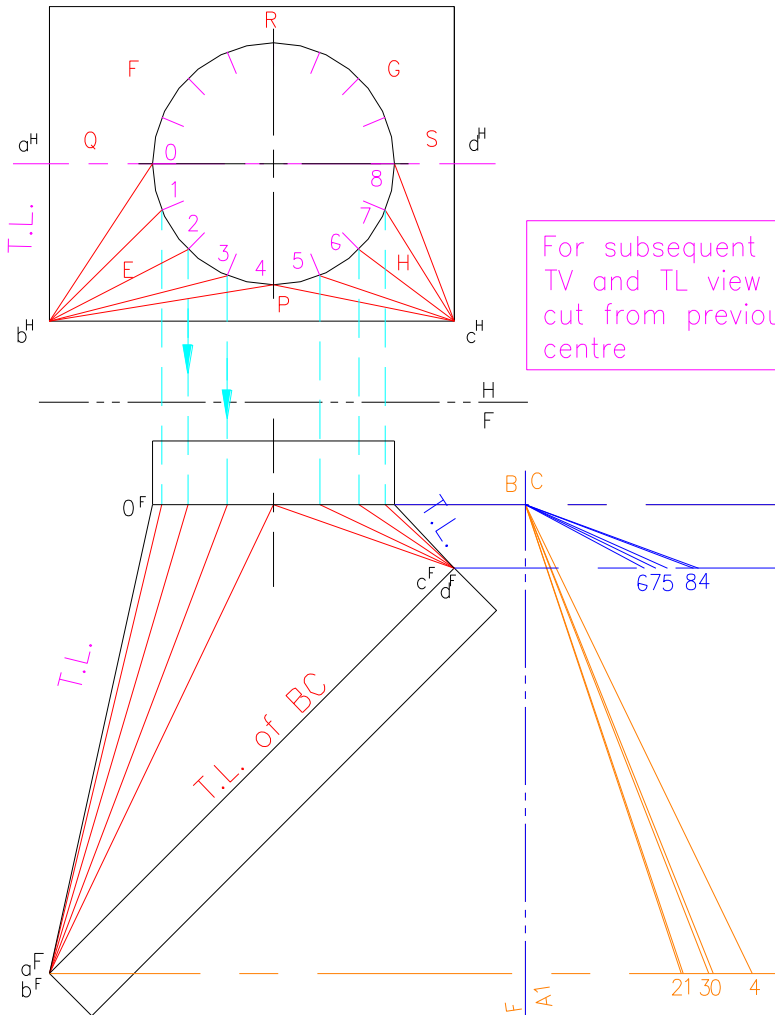

HALF DEVELOPMENT

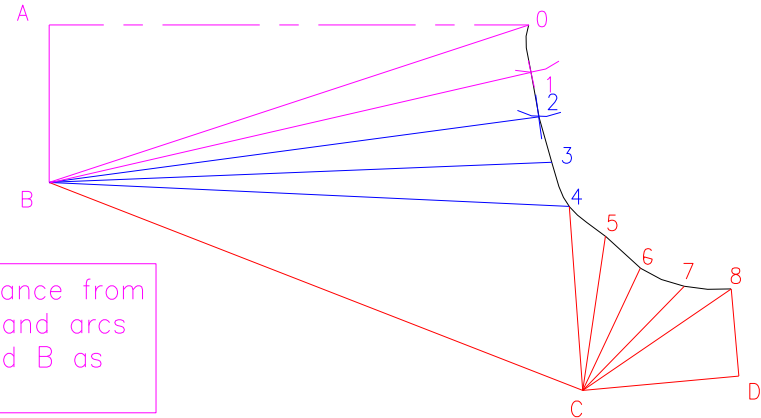

For subsequent points, distance from TV and TL view are taken and arcs cut from previous point and B as centre

Circle is divided into 16 equal parts, only front part considered for development (Symmetry)

The cone elements are drawn in both views using the points

Obtain TL of elements in cone E by rotation. distances from axis FA1 taken from TV. 0 and 4 shown as eg. repeat for other points as well

Repeat the same for cone H. 5 & 8 shown as eg.

Half triangle (Q) ABO is developed using TL of AB from TV, TL of AO from FV and TL of BO from the TL view

For triangle (P) B4C, C is located with arcs from centres of B and 4 and distances

For subsequent points, distance from TV and TL view are taken and arcs cut from previous point and C as centre

Intersection of two Prisms

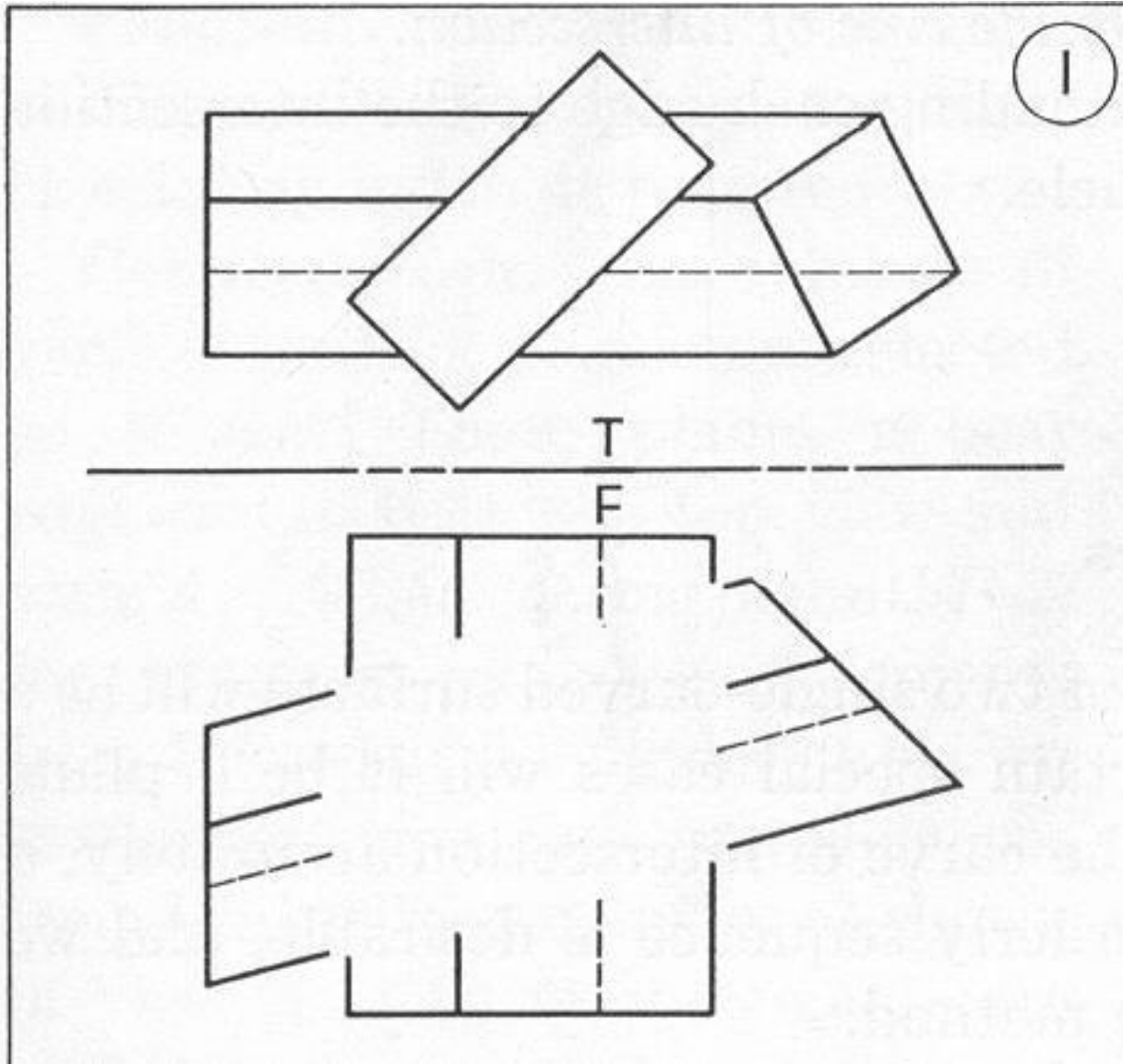

Cutting plane method

The problem shows one vertical prism and one inclined prism.

The intersection figures must be found.

Intersection of two Prisms

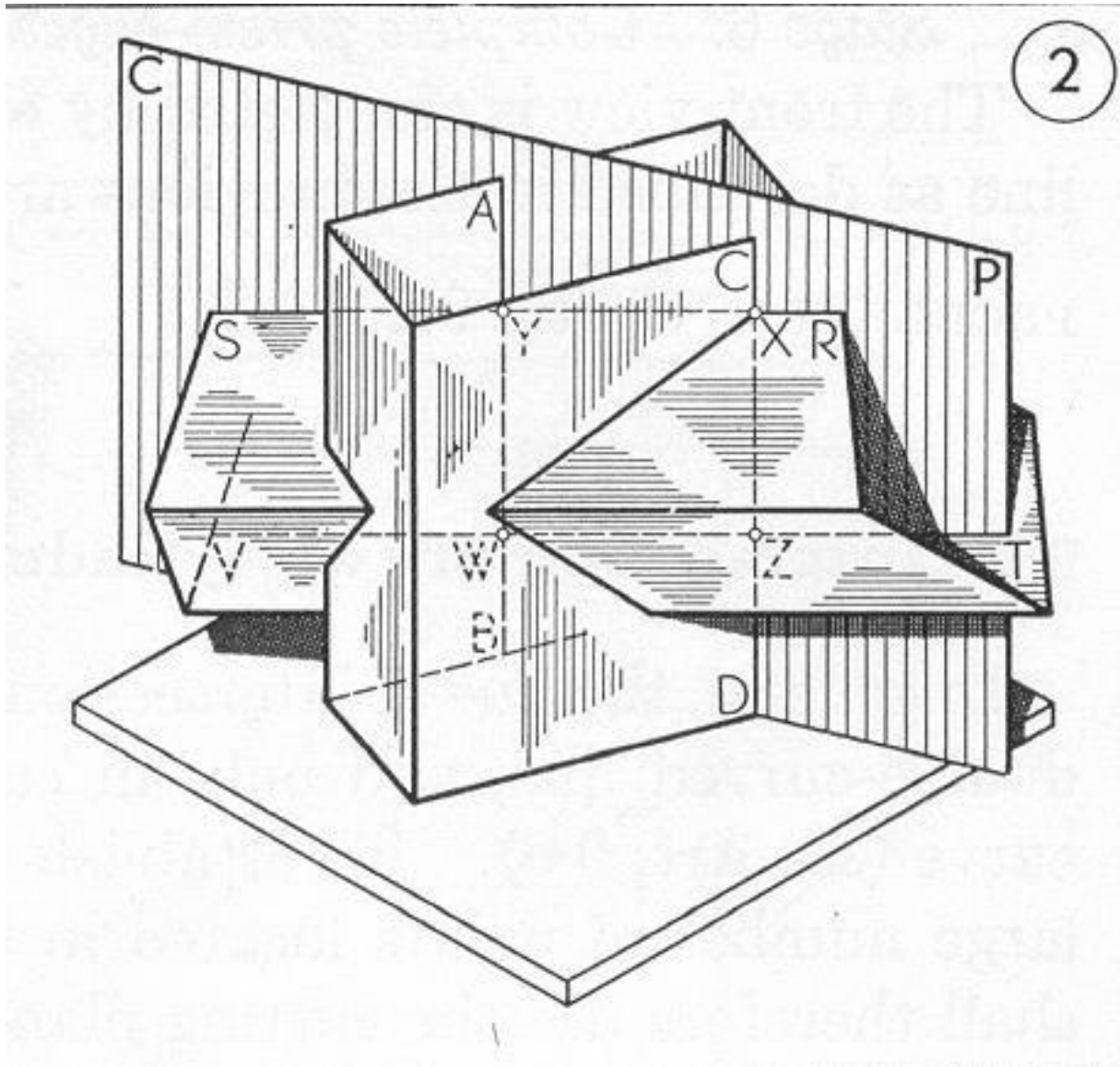

The CP is chosen across one edge of the prism (RS).

This plane cuts the lower surface at VT and the other prism at AB and CD.

All 4 points (WZYX) line up with both the prisms and the cutting plane.

These are the required points of intersection.

Intersection of two Prisms

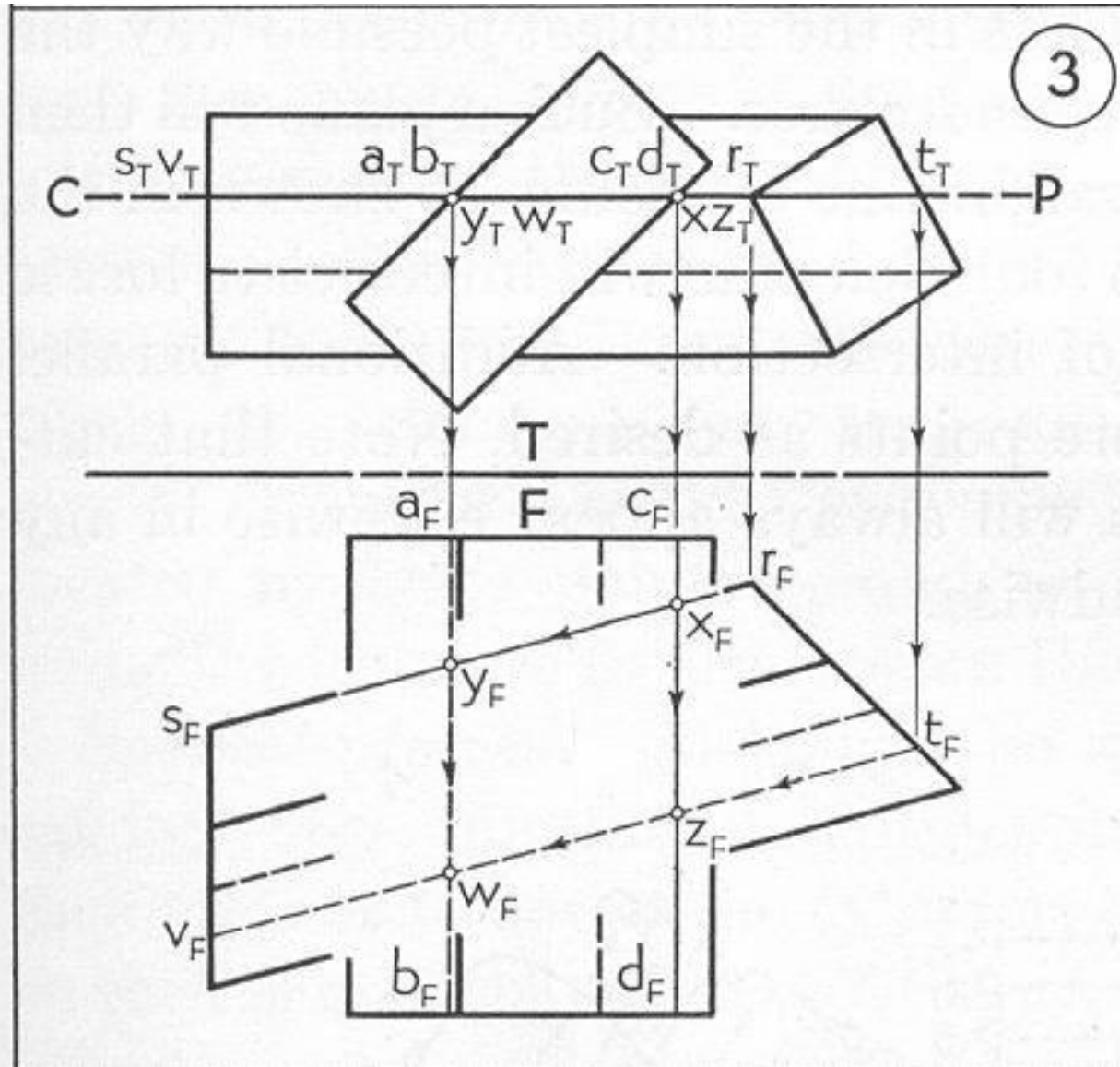

The cutting plane shown in multiview projection.

The points are visible in the 3D view.

Intersection of two Prisms

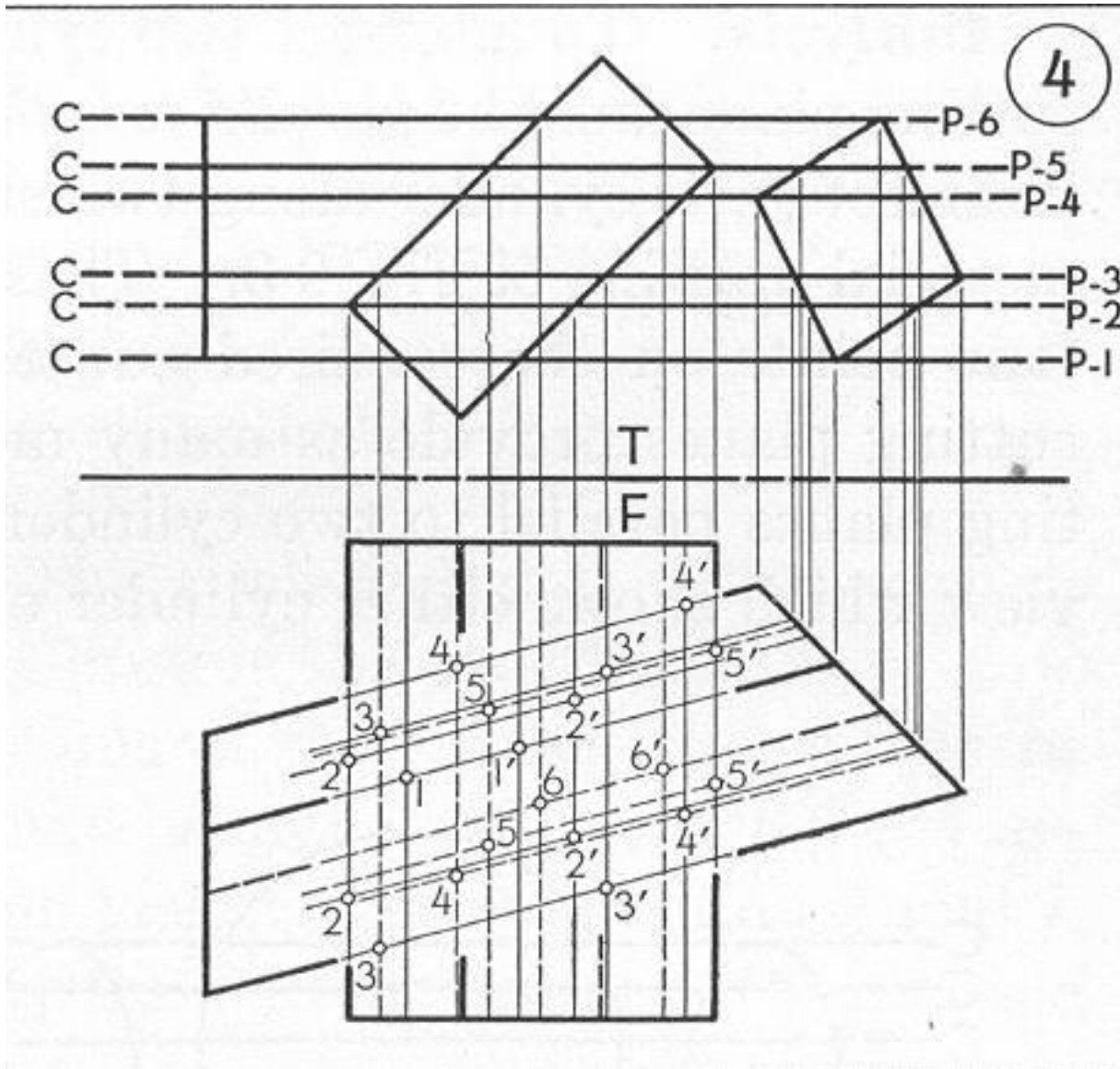

Six cutting planes are required

Locate the points of intersection from the cutting planes and locate the points in the front view.

Intersection of two Prisms

5

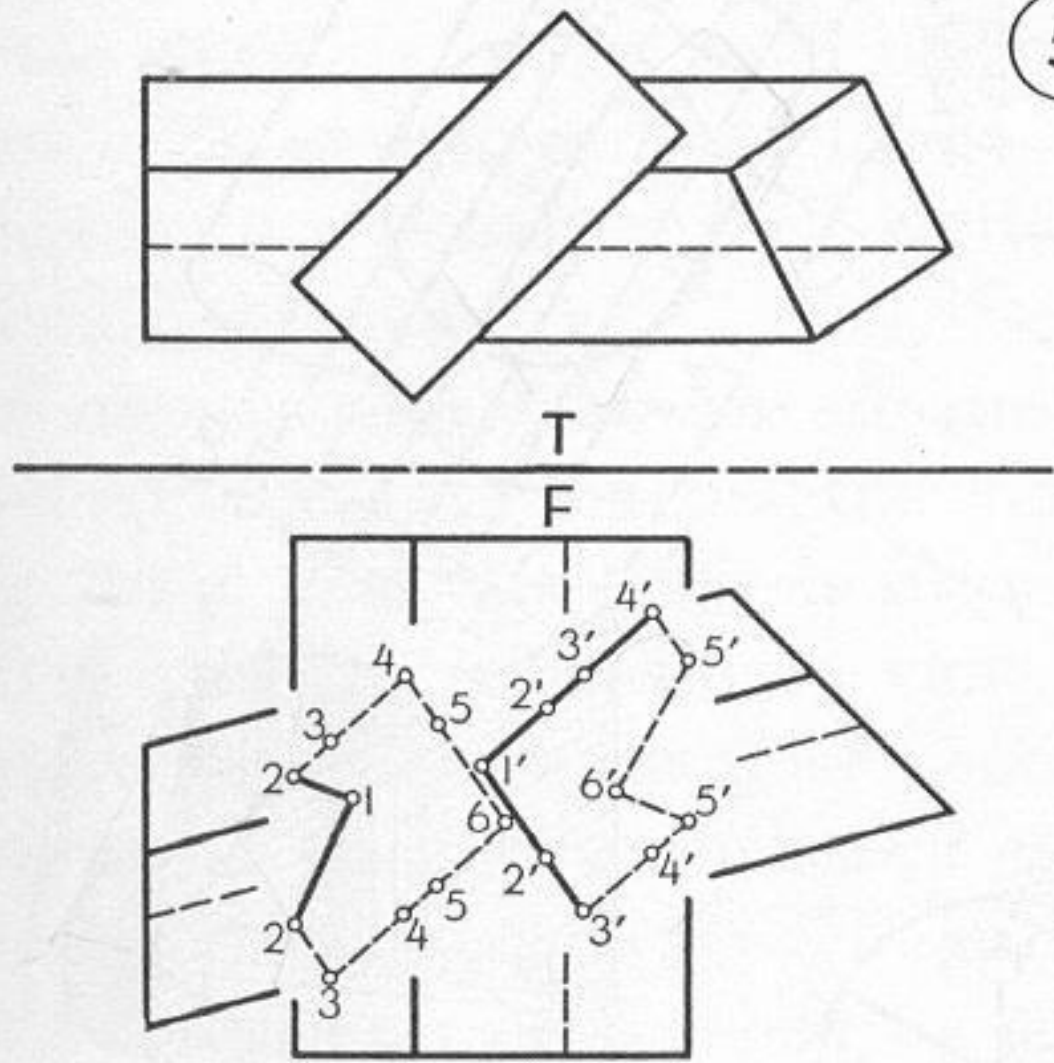

The points are connected in the front view with regards to visibility and sequence.

Developments

In sheet metal layout, extra material must be provided for laps or seams.

If the material is thick, bend allowance (BA) must be considered.

$$BA = (0.017453R + 0.0078T)N$$

R = radius of bend; **T** = Thickness of material; **N** = degree of bend.

Neutral axis C is assumed to be $(0.44 \times T)$ from inside of the bend.

