

MECH 211 – Mechanical Engineering Drawing

François Tardy

Credits: 3.5

Lecture 13

Review and Sample Problems

Exam Logistics

1. Missing views, auxiliary views, Section views.
2. Missing views, auxiliary views, Section views.
3. Points, lines and Planes.
4. Points lines and Planes.
5. Intersection or Development.
6. Abstract design problems.

Note: All questions carry equal marks and no materials allowed except drawing instruments and calculator

Lecture 1

Multi View Drawings

- you need to practice imagination and try doing some missing line problems and other views given in the book.
- You can also work on the example problems in the slides.
- To help you do this, you can look at the following website.
- <http://www.prenhall.com/giesecke> (the website given in the book).

Lecture 2

Graphic constructions

- Line perpendicular to a segment passing through the middle point
- Bisection line of an angle
- Tri-section lines of a 90° angle
- A hexagon inscribed into a given circle
- A point on a segment that divides the line in a given ratio
- Laying out an angle, transferring triangle
- Arc tangent to lines and arcs
- And other things that you see in the book as well

Lecture 3

Sectional Views

- Full Sections, Half Sections
- Offset Sections
- Broken Sections
- Revolved Sections

Sections through assemblies

- Do not section, shafts, bolts etc. and other objects like ribs, webs, etc.
- Attention to direction of section lines
- Thin objects (gaskets, seals) are sectioned (filled) with thick lines
- Rotate objects to avoid to improve clarity, when odd number of spokes in a circle etc.

Lecture 3

Auxiliary views

- Primary auxiliary view.
- Depth, width and height auxiliary view.
- Folding line method.
- Always take the projection lines in the direction of view, and take the distances from the previous view.

Secondary auxiliary view

- Drawn from the primary auxiliary view.

Lecture 4

- Particular positions of a line – horizontal, frontal or profile
- True length of a line – selected auxiliary views
- Bearing of a line (in the top view, N(S) nn E(W))
- Slope of a line (from the top view, draw a TL in aux view – elevation view)
- Point view of a line – second aux. View (first aux view to get TL)
- Relative position of a point vs. a line (to see if point is on the line or not)
- Relative position of two lines ($//$, X or skew)
- Parallel lines; rule of parallel lines (exceptions) always seen parallel except
- when they are parallel to the folding line you need the third view

Lecture 4

- True distance between two parallel lines.
 - See the lines as points and find the distance between them.
- Intersecting lines – identification through inspection.
- Skewed lines – visibility drawn from adjacent view.
- Perpendicular lines – rule of perpendicular lines.
 - A 90° angle appears in true size in any view showing one leg in TL.
 - Provided the other leg does not appear as point view.
- Two intersecting lines are perpendicular if the TL projection is making 90° with the other line.

Lecture 5

Distance from a point to a line

- Perpendicular to line and from the point is the shortest distance
- Go to the point view of the line and project the point too.
- Draw line between the 2 points and it has to be parallel to the FL and 90° to the line (the distance is the TL line)
- Project the line in all the views

Location of a perpendicular line at a give location on a line

- Same as above, find the point view of the line
- You can have multiple solutions unless a direction is given
- If direction given, Draw line from the point in that direction
- Adjacent view has to be parallel to the FL and 90° to the line and it should be where the point is
- Project this line in all the views

Checking for Skewed lines

- If point cannot be transmitted to adjacent views

Lecture 5

Shortest Distance between 2 skewed lines

- Perpendicular to line and from the point view of the other line is the shortest distance
- Go to the point view of one line and project the other line too.
- Draw line between the points and the line at 90° and it has to be parallel to the FL and 90° to the line (the distance is the TL line)
- Project the line in all the views

Location of a line through a point intersecting 2 skewed lines

- Construct a plane with one line and the point
- Use cutting plane method to find the piercing point
- Draw a line from the piecing point to the given point and extend it to the other line in the problem

Lecture 5

Strike of a plane

- Bearing of a TL line in the plane is the strike of the plane.

Edge View of a plane

- Draw TL line (draw a line parallel to the FL in one view and project the points of intersection with the plane to the adjacent view).
- If you see the TL as point, you will see the plane as an edge.

Slope or dip of a plane

- The angle that the EV of a plane makes with the horizontal FL.

Shortest line from point to plane

- Find the EV of the plane and project the point as well.
- Draw a line 90° to the plane from the point and make it TL by Tracing back with perp from TL in the adjacent view.
- For the next view use the distance from the folding line.

Lecture 5

Shortest horizontal and grade line from point to plane

- Same as previous but the lines should have an angle parallel to the horizontal FL for horizontal line or parallel to a line which is at a given angle to horizontal FL for grade line
- Make it TL by Tracing back with perp from TL in the adjacent view.
- For the next view use the distance from the folding line

True shape of a plane

- Secondary aux view adjacent to the edge view of the plane
- Used to find TS of oblique surfaces or centre of oblique circle etc.

Angle of line with oblique plane

- Line in TL and plane in EV.
- First get the EV and project the line. Next get the TS of the plane
- Next get the TL of the line in third aux view

Lecture 6

Angle between intersecting lines in a plane

- Can be found if the plane is in its TS

Dihedral angle

- Find the line of intersection between the planes
- Get the TL of the intersection line and its point view
- In that view you will see the planes as EV and angle is dihedral angle

Angle of line with oblique plane

- Line in TL and plane in EV.
- First get the EV and project the line. Next get the TS of the plane
- Next get the TL of the line in third aux view

Lecture 6

Shortest line between 2 skewed lines EV method

- Create a plane with one line and parallel to the other line
- EV of the plane will give 2 parallel lines. (distance (90°) between these lines is the shortest distance
- Draw secondary aux view to see the lines as TL and they will intersect at a point
- Project this point back to views that will give you the line in all views

Shortest horizontal and Grade line between 2 skewed lines - EV method

- Same as previous except point 3
- Aux views are drawn parallel to horizontal FL for horizontal line and parallel to a line drawn at a given angle to the horizontal FL.
- Project this point back to the views

Line intersecting a plane

- If line is not parallel to plane it should intersect (piercing point)

Lecture 6

Piercing Point - CP Method

- Draw a CP whose EV coincides with the line in any one view.
- Project the points of intersection with the lines in the plane to the adjacent view.
- Draw a line between these points and find the intersection of this line (which is the projection of the cutting plane) with the original line.
- This gives the piercing point in that view. Project this point to the line on the adjacent view.
- For visibility get the information from the adjacent view.

Piercing Point - EV Method

- Draw the EV of the plane and project the line in that view.
- Find the point of intersection and project the point back to the line in the views.

Lecture 6

Intersection of Planes EV method

- Find EV of one plane project the other plane in that view
- You will get 2 piercing points in that view
- Project the points back to the corresponding lines in the views and complete the line of intersection

Intersection of Planes - CP Method

- Coincide the EV of CP with one of the lines in one plane and find one piercing point in both views
- Repeat with another cutting plane and find the other piercing point
- Join these two to get the line of intersection

From lecture 7 all the points are clearly given next to the drawing itself

LECTURE 7 AND ABOVE

Sample Problems

Given the front and top views of a plane, a-b-c.

Question 1: starting from point c, draw a declined line, c-d, with a true length of 20 mm and perpendicular to the plane a-b-c

Question 2: connect points b and d and find the bearing and slope of line b-d.

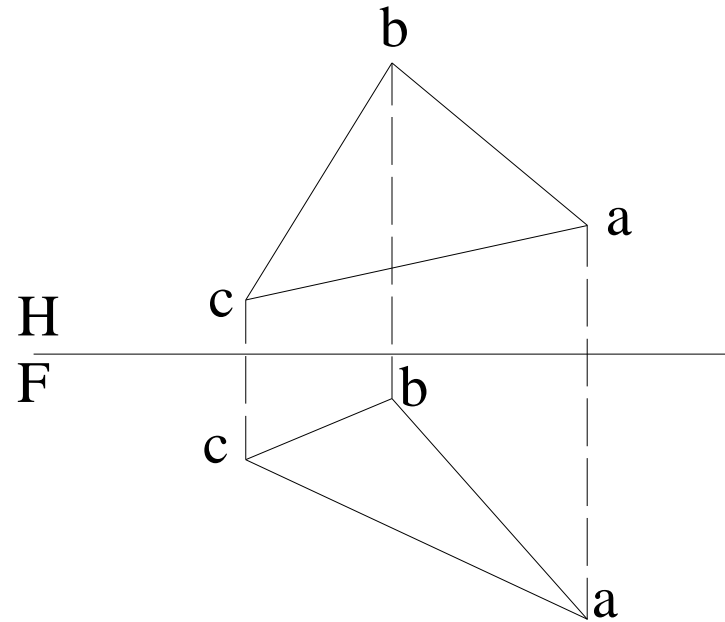

Sample Problems

Given the front and top views of a plane, a-b-c.

Question 1: starting from point c, draw a declined line, c-d, with a true length of 20 mm and perpendicular to the plane a-b-c

Question 2: connect points b and d and find the bearing and slope of line b-d.

The solution can be found based on the print-out of this question. In the first auxiliary view, find the point d on line c-e and with a length of 20 mm. Project point d back to the top view and the front view. The bearing of line b-d can be then found.

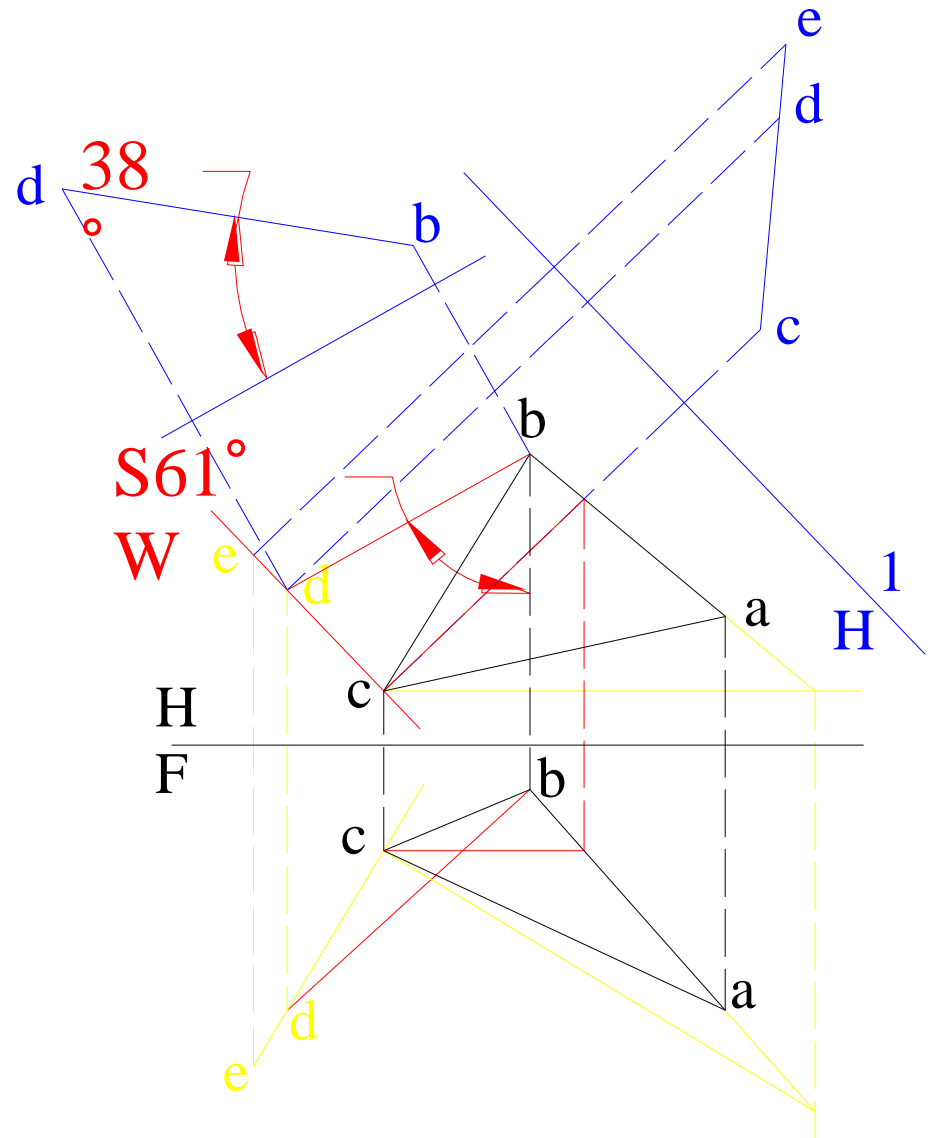

Sample Problems

The edge view of the circle with quadrants a-b-c-d is given in the top view.

Draw the missing views and the auxiliary view to show the true size of the circle and mark its diameter.

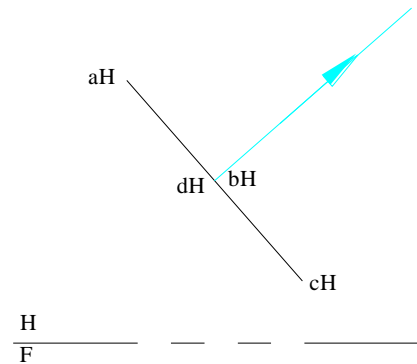

Sample Problems

The edge view of the circle with quadrants a-b-c-d is given in the top view.

Draw the missing views and the auxiliary view to show the true size of the circle and mark its diameter.

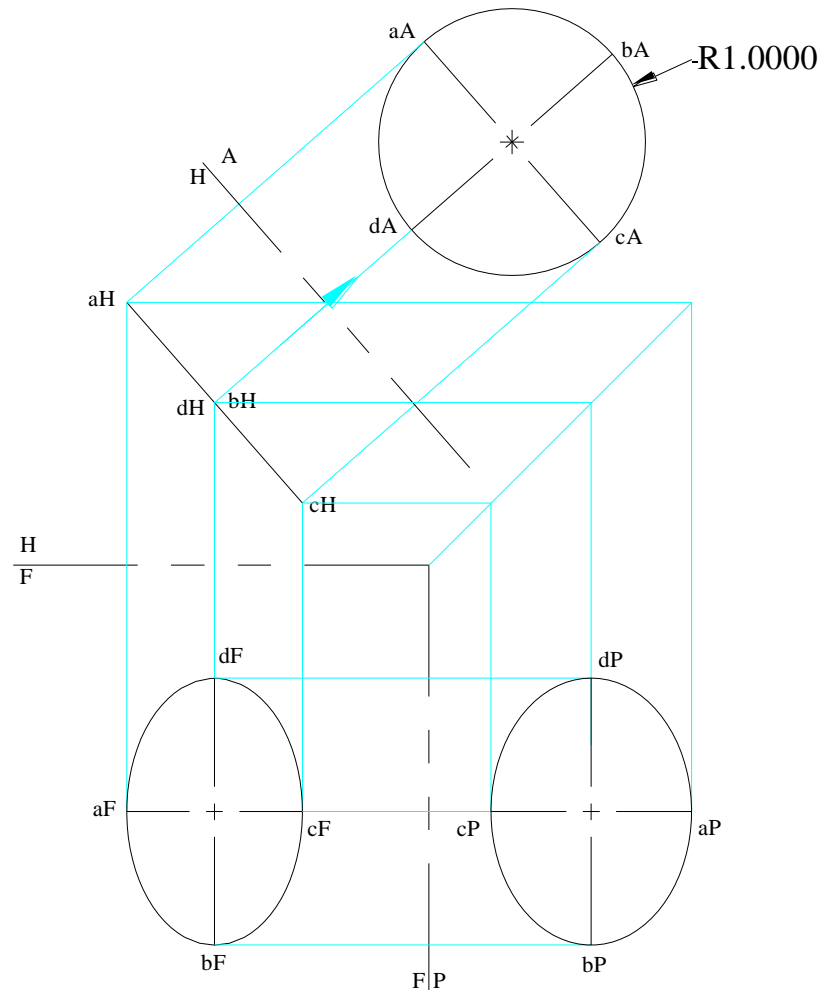

Sample Problems

The top view of the Throttle Body is given.

Draw the full sectional front view using the guide in dotted line and the auxiliary view for height details. Follow the conventions of drawing sectional views.

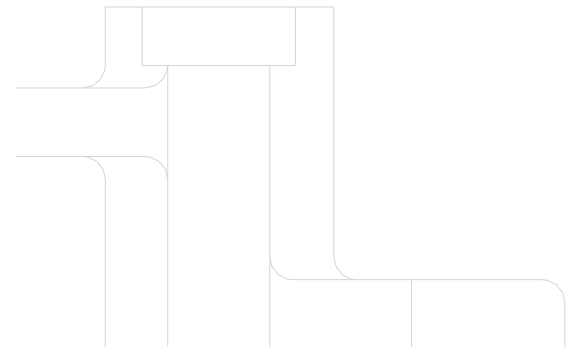
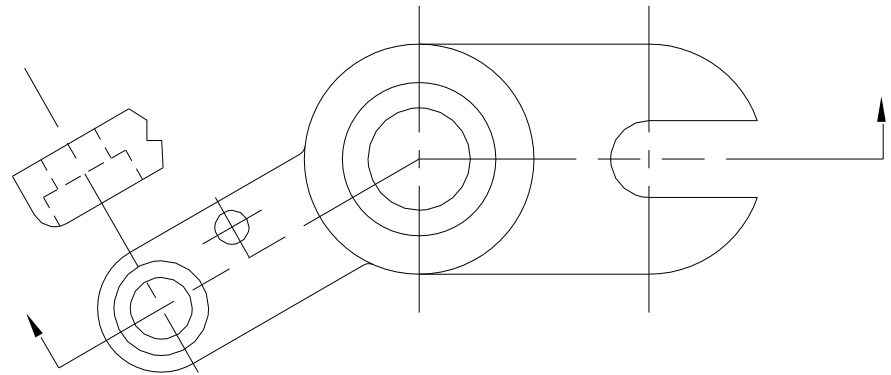

Sample Problems

The top view of the Throttle Body is given.

Draw the full sectional front view using the guide in dotted line and the auxiliary view for height details. Follow the conventions of drawing sectional views.

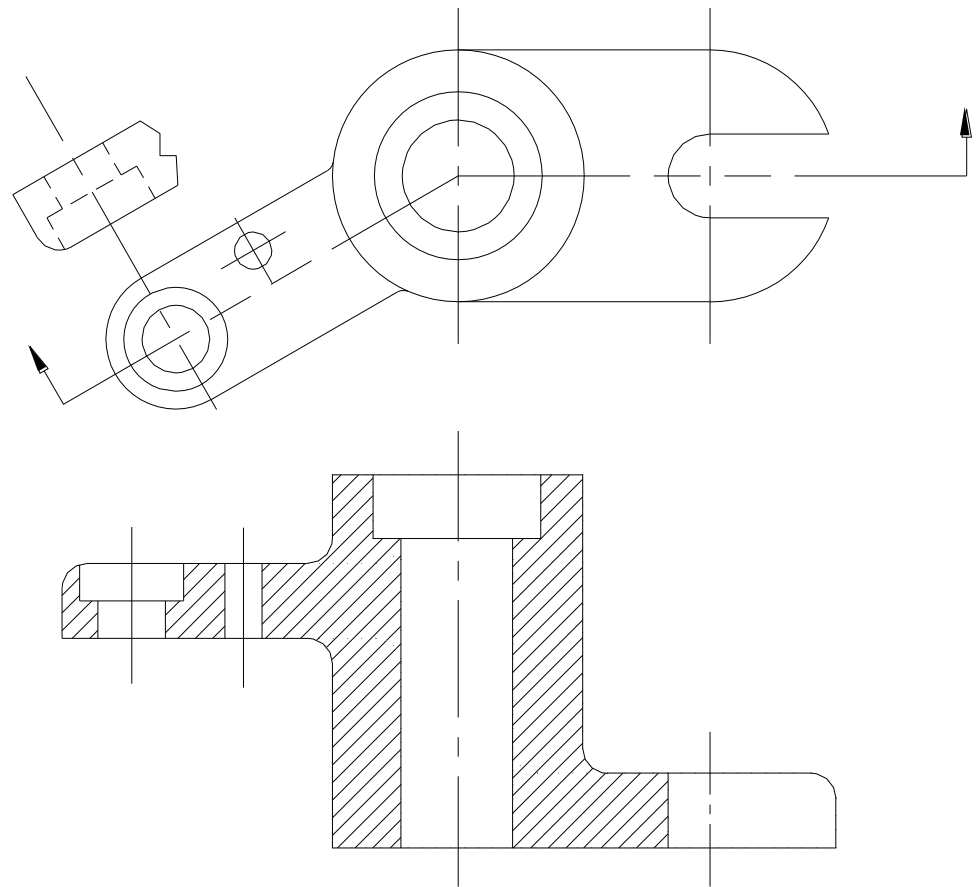

Lectures 7 - 9

From lectures 7 to 9, all the points regarding the construction for intersections and developments are clearly given next to the drawing itself, on the slides.

Sample Problems



Exam Logistics

- Missing views, auxiliary views, Section views
- Missing views, auxiliary views, Section views
- Points, lines and Planes
- Points lines and Planes
- Intersection or Development
- Abstract design problems

Note: All questions carry equal marks and no materials are allowed except drawing instruments and calculator.

MID TERM EXAMINATION MECH 211, FALL 2012

Answer on the same sheet where the questions are. Closed book examination. It is an exam, not group work. Total time for the midterm examination is 110 minutes. Total value of the Midterm Exam is 40 marks

1. Given 3 points, draw the circle that passes through this points. Mark the diameter of that circle on the drawing.
2. Draw arcs of 25mm diameter tangential to both these circles on circles on either side
3. Inside the smaller circle there is a hexagon centrally inscribed in a circle of dia 25mm. The sides of the hexagon has to be parallel to the horizontal direction

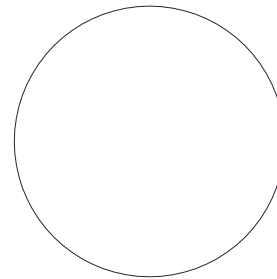

Concordia University
Department of Mechanical and
Industrial Engineering

Midterm Exam

29 Oct 2012

110 Minutes

10 Marks

Problem #1

Name and Surname

I.D.#

MID TERM EXAMINATION MECH 211, FALL 2012

Answer on the same sheet where the questions are. Closed book examination. It is an exam, not group work. Total time for the midterm examination is 110 minutes. Total value of the Midterm Exam is 40 marks

1. Given 3 points, draw the circle that passes through this points. Mark the diameter of that circle on the drawing.
2. Draw arcs of 25mm diameter tangential to both these circles on circles on either side
3. Inside the smaller circle there is a hexagon centrally inscribed in a circle of dia 25mm. The sides of the hexagon has to be parallel to the horizontal direction

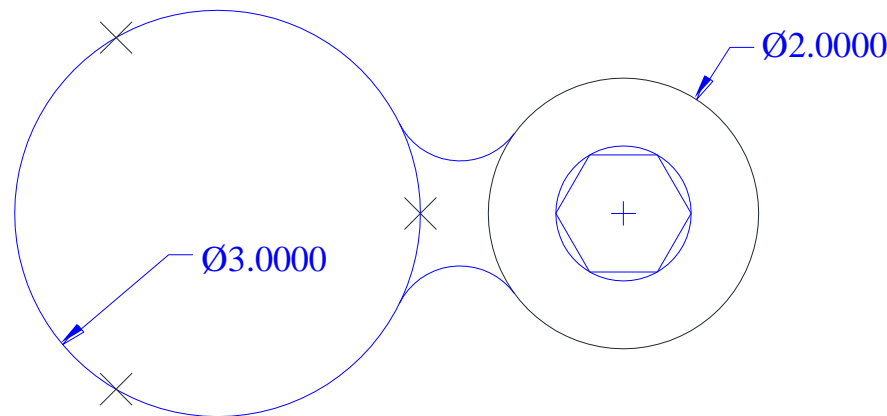

Concordia University
Department of Mechanical and
Industrial Engineering

Midterm Exam

29 Oct 2012
110 Minutes

10 Marks
Problem #1

Name and Surname

I.D.#

Draw the Isometric View here

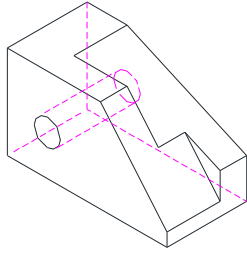

Draw the Partial Auxiliary View here

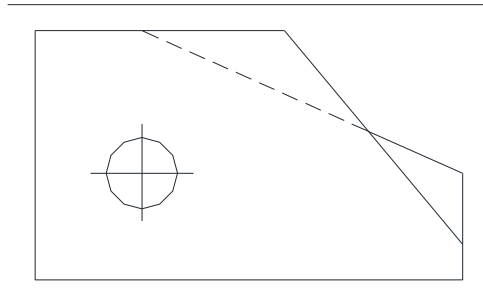
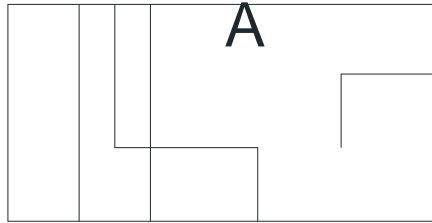

Given the Front, Top and Isometric view of the object, draw the :

1. Missing Right Side View at the appropriate position
2. Parital auxiliary view to show the true shape of the surface 'A'

Concordia University
Department of Mechanical and
Industrial Engineering

Midterm Test

Date: 29 Oct 2012

Time: 110 Mins

10 Marks

Problem # 2

Name and Surname

I.D.#

Draw the Isometric View here

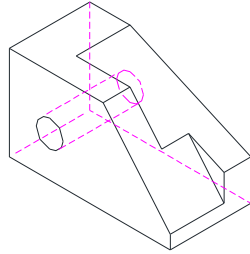

Draw the Partial Auxiliary View here

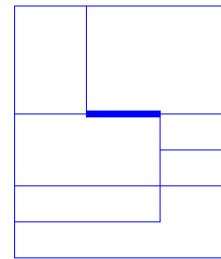
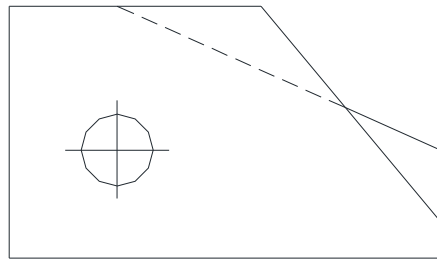
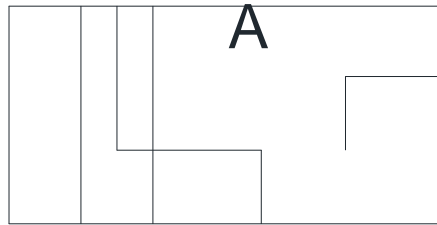

- Given the Front, Top and Isometric view of the object, draw the :
1. Missing Right Side View at the appropriate position
 2. Partial auxiliary view to show the true shape of the surface 'A'

Concordia University
Department of Mechanical and
Industrial Engineering

Midterm Test

Date: 29 Oct 2012
Time: 110 Mins

10 Marks
Problem # 2

Name and Surname

I.D.#

Draw the Isometric View here

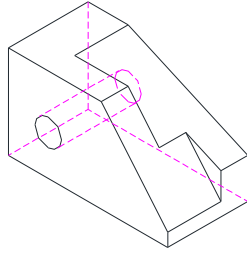

Draw the Partial Auxiliary View here

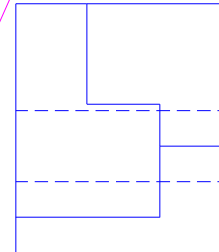
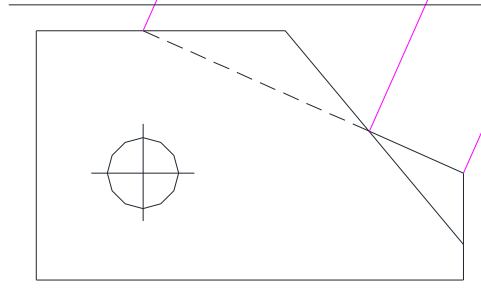
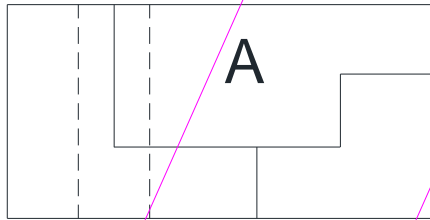

Given the Front, Top and Isometric view of the object, draw the :

1. Missing Right Side View at the appropriate position
2. Parital auxiliary view to show the true shape of the surface 'A'

Concordia University
Department of Mechanical and
Industrial Engineering

Midterm Test

Date: 29 Oct 2012
Time: 110 Mins

10 Marks
Problem #2

Name and Surname

I.D.#

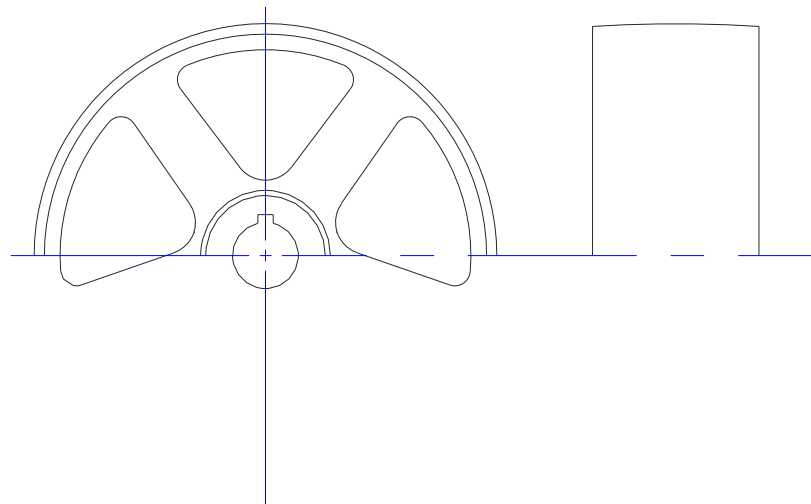
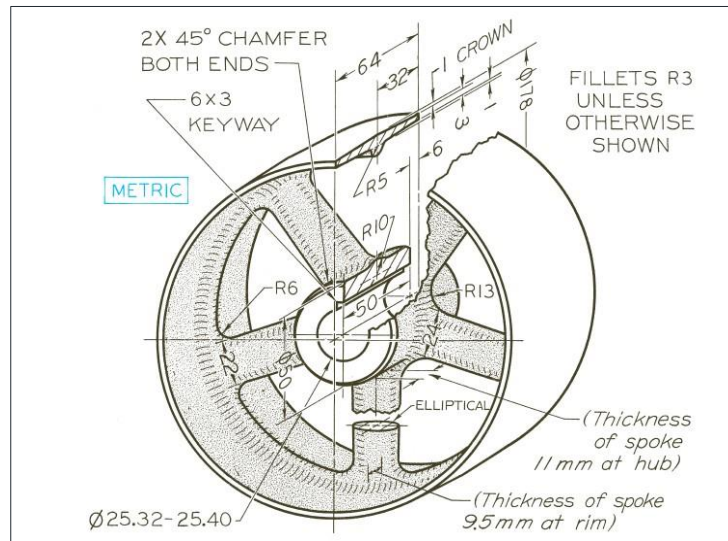

Given the partial FV and SV, complete Drawing the Front View with the revolved section of the spoke, and Right Side View with full section Also show the section line on the drawing

Concordia University
Department of Mechanical and
Industrial Engineering

Midterm Exam

29 Oct 2012

110 Minutes

10 Marks

Problem # 3

Name and Surname

I.D.#

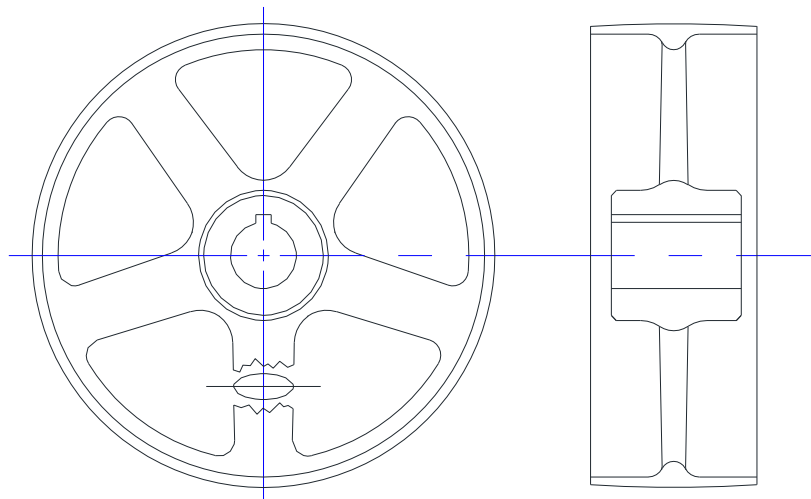
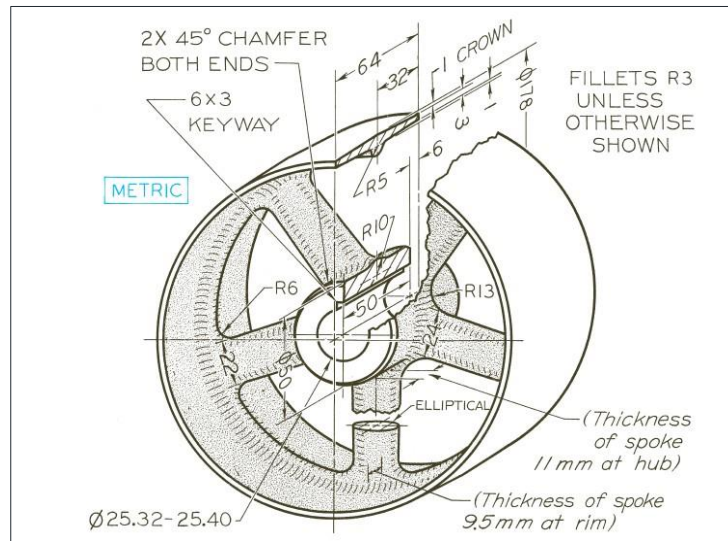

Given the partial FV and SV, complete Drawing the Front View with the revolved section of the spoke, and Right Side View with full section Also show the section line on the drawing

Concordia University
Department of Mechanical and
Industrial Engineering

Midterm Exam

29 Oct 2012
110 Minutes

10 Marks
Problem # 3

Name and Surname

I.D.#

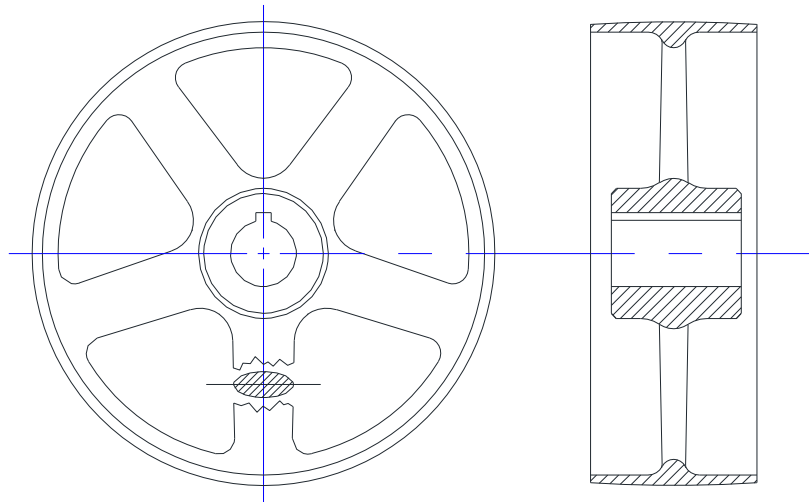
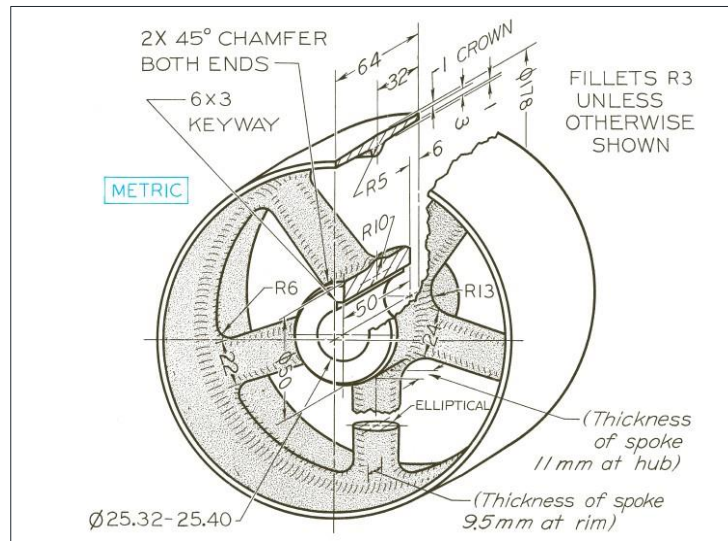

Given the partial FV and SV, complete Drawing the Front View with the revolved section of the spoke, and Right Side View with full section Also show the section line on the drawing

Concordia University
Department of Mechanical and
Industrial Engineering

Midterm Exam

29 Oct 2012

110 Minutes

10 Marks

Problem # 3

Name and Surname

I.D.#

Hint: use the Arrow point for intersection of aux fold lines. Also the arrow points North

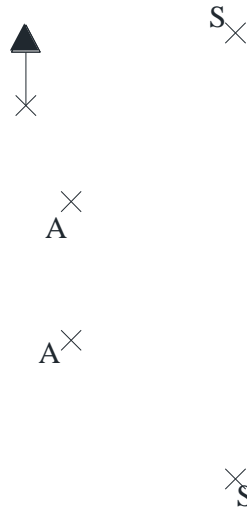

Views of **points A and S are given.**

- a) Draw a line AB such that B is 100mm to the right of, 50mm below and 50mm behind A
- b) Find the bearing and slope of line AB
- c) What's the shortest distance between Point S and Line AB

Concordia University
 Department of Mechanical and
 Industrial Engineering

Midterm Exam

29 Oct 2012

110 Minutes

10 Marks

Problem # 4

Name and Surname

I.D.#

Hint: use the Arrow point for intersection of aux fold lines. Also the arrow points North

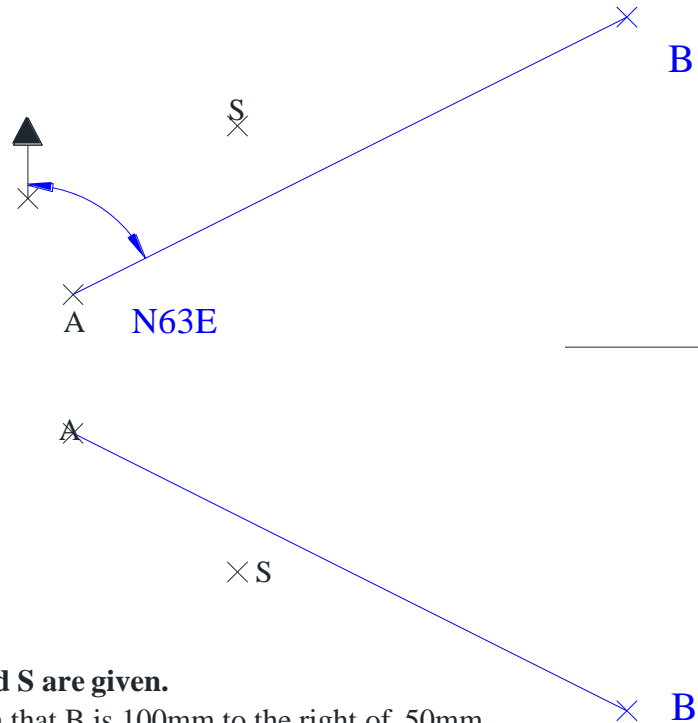

Views of **points A and S** are given.

- Draw a line AB such that B is 100mm to the right of, 50mm below and 50mm behind A
- Find the bearing and slope of line AB
- What's the shortest distance between Point S and Line AB

Concordia University
Department of Mechanical and
Industrial Engineering

Midterm Exam

29 Oct 2012

110 Minutes

10 Marks

Problem # 4

Name and Surname

I.D.#

Hint: use the Arrow point for intersection of aux fold lines. Also the arrow points North

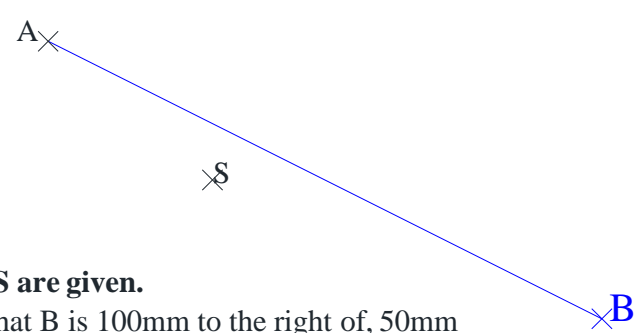
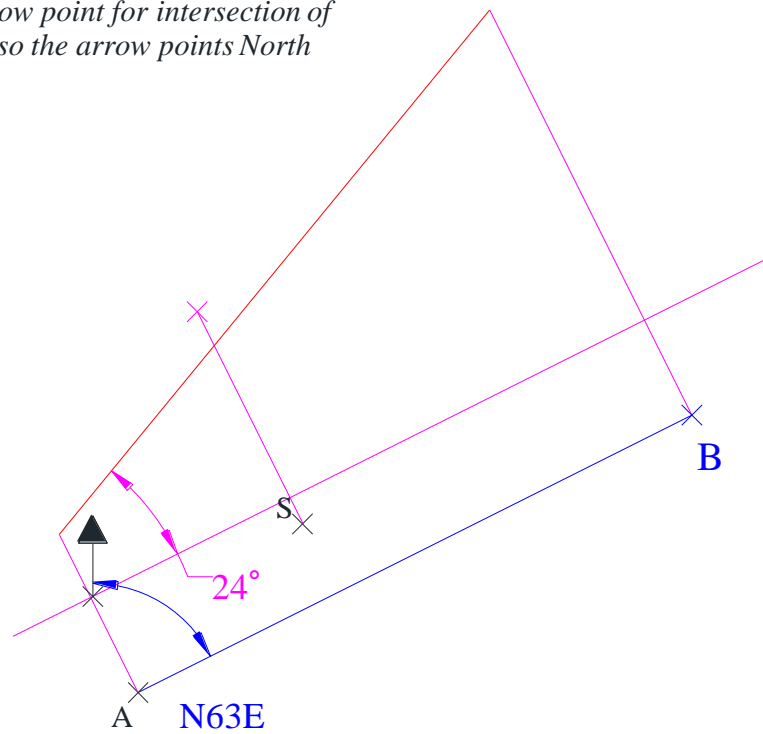

Views of points A and S are given.

- Draw a line AB such that B is 100mm to the right of, 50mm below and 50mm behind A
- Find the bearing and slope of line AB
- What's the shortest distance between Point S and Line AB

Concordia University
Department of Mechanical and
Industrial Engineering

Midterm Exam

29 Oct 2012
110 Minutes

10 Marks
Problem # 4

Name and Surname

I.D.#

Hint: use the Arrow point for intersection of aux fold lines. Also the arrow points North

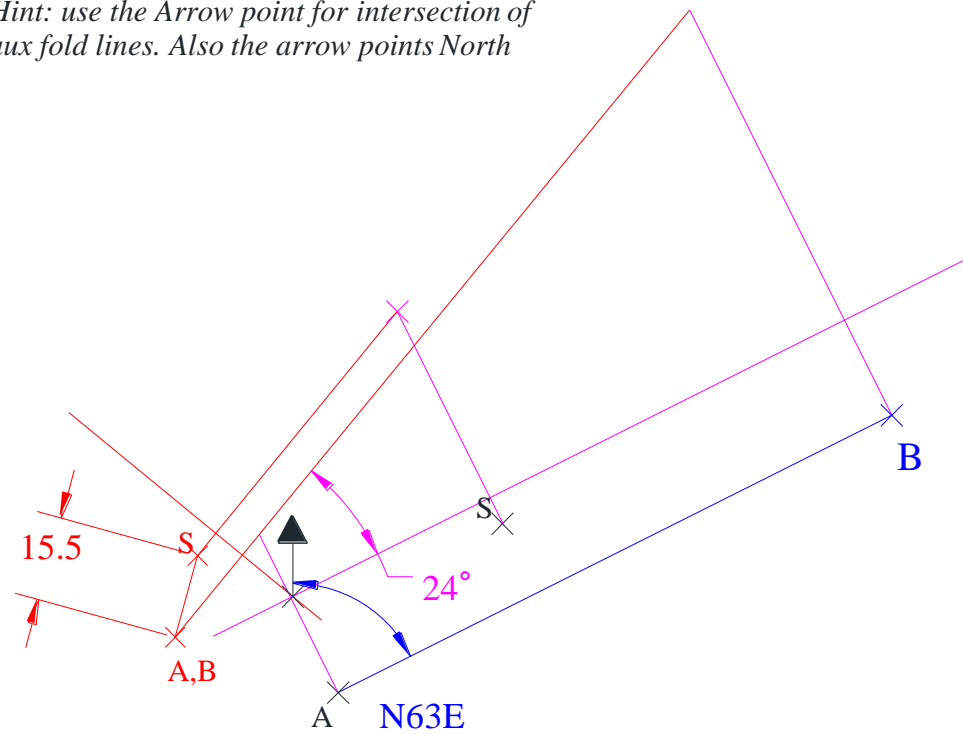

Views of points A and S are given.

- Draw a line AB such that B is 100mm to the right of, 50mm below and 50mm behind A
- Find the bearing and slope of line AB
- What's the shortest distance between Point S and Line AB

Concordia University
Department of Mechanical and
Industrial Engineering

Midterm Exam

29 Oct 2012
110 Minutes

10 Marks
Problem # 4

Name and Surname

I.D.#

Sample Problems

Given the front and top views of a plane, a-b-c. Question: (1) starting from point c, draw a declined line, c-d, with a true length of 20 mm and perpendicular to the plane a-b-c; and (2) connect points b and d and find the bearing and slope of the line b-d.

The solution can be found based on the print-out of this question. In the first auxiliary view, find the point d on line c-e and with a length of 20 mm. Project point d back to the top view and the front view. The bearing of line b-d can be then found.

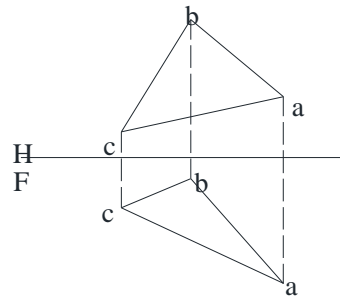

Concordia University
Department of Mechanical and
Industrial Engineering

Midterm Test

Date:

Problem #

Name and Surname

I.D.#

Given the front and top views of a plane, a-b-c. Question: (1) starting from point c, draw a declined line, c-d, with a true length of 20 mm and perpendicular to the plane a-b-c; and (2) connect points b and d and find the bearing and slope of the line b-d.

The solution can be found based on the print-out of this question. In the first auxiliary view, find the point d on line c-e and with a length of 20 mm. Project point d back to the top view and the front view. The bearing of line b-d can be then found.

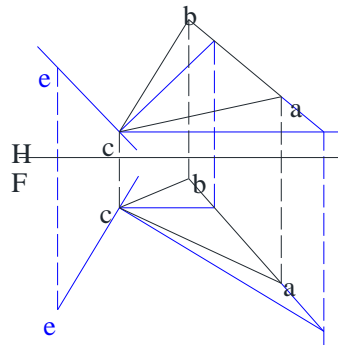

Concordia University
Department of Mechanical and
Industrial Engineering

Midterm Test

Date:

Problem #

Name and Surname

I.D.#

Given the front and top views of a plane, a-b-c. Question: (1) starting from point c, draw a declined line, c-d, with a true length of 20 mm and perpendicular to the plane a-b-c; and (2) connect points b and d and find the bearing and slope of the line b-d.

The solution can be found based on the print-out of this question. In the first auxiliary view, find the point d on line c-e and with a length of 20 mm. Project point d back to the top view and the front view. The bearing of line b-d can be then found.

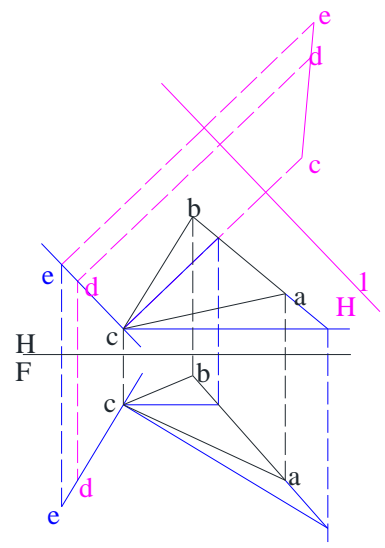

Concordia University
Department of Mechanical and
Industrial Engineering

Midterm Test

Date: _____ Problem # _____

Name and Surname I.D.# _____

Given the front and top views of a plane, a-b-c. Question: (1) starting from point c, draw a declined line, c-d, with a true length of 20 mm and perpendicular to the plane a-b-c; and (2) connect points b and d and find the bearing and slope of the line b-d.

The solution can be found based on the print-out of this question. In the first auxiliary view, find the point d on line c-e and with a length of 20 mm. Project point d back to the top view and the front view. The bearing of line b-d can be then found.

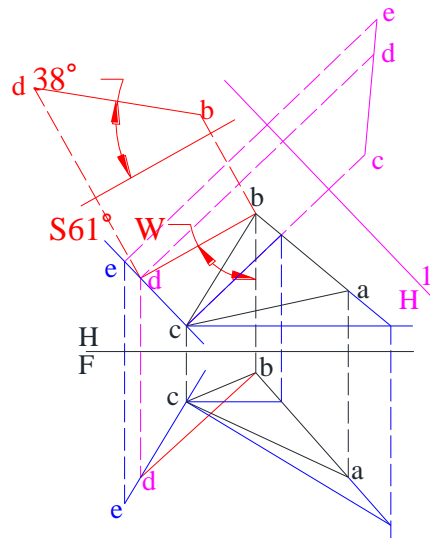

Concordia University
Department of Mechanical and
Industrial Engineering

Midterm Test

Date:

Problem #

Name and Surname

I.D.#

Sample Problems

Edge view of the circle with quadrants abcd is given in the top view. Draw the missing views and the auxiliary view to show the true size of the circle and mark its diameter.

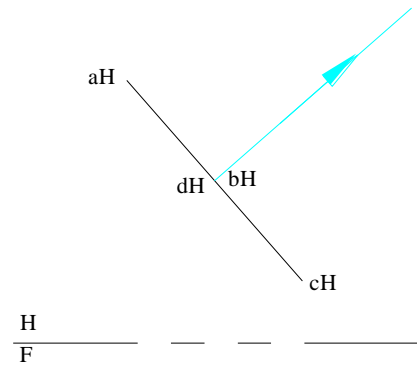

Edge view of the circle with quadrants abcd is given in the top view. Draw the missing views and the auxiliary view to show the true size of the circle and mark its diameter.

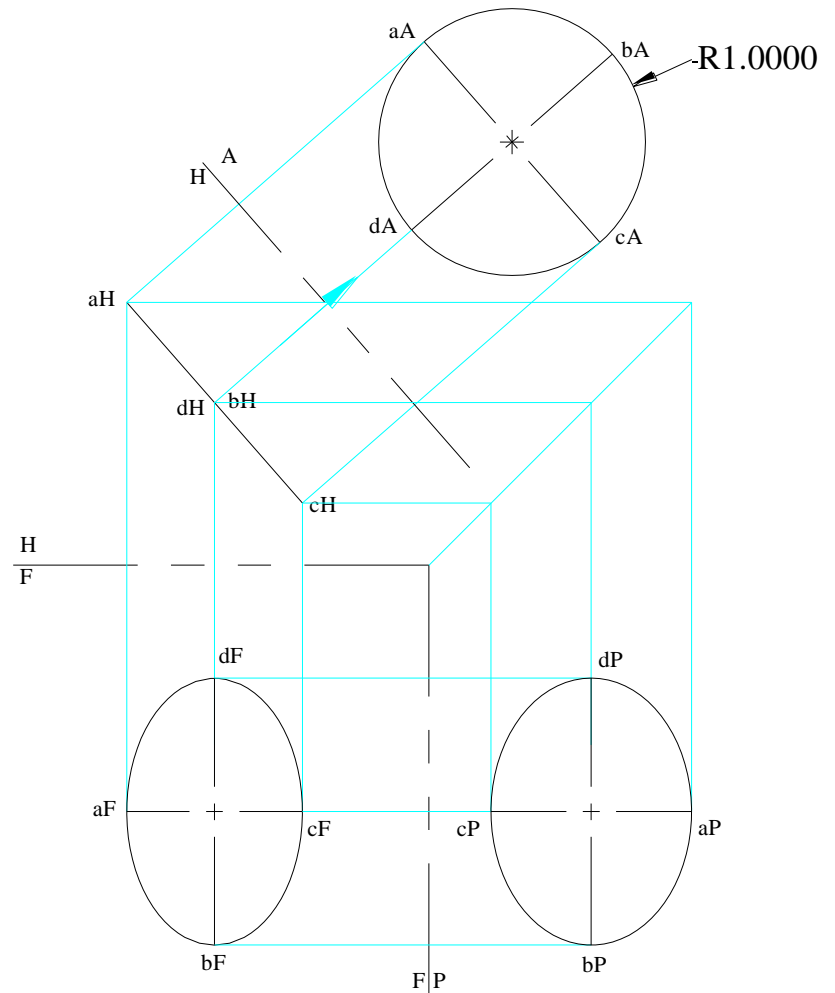

The top view of the Throttle Body is given.
Draw the full sectional front view using the guide in
dotted line and the auxiliary view for height details.
Follow the conventions of drawing sectional views.

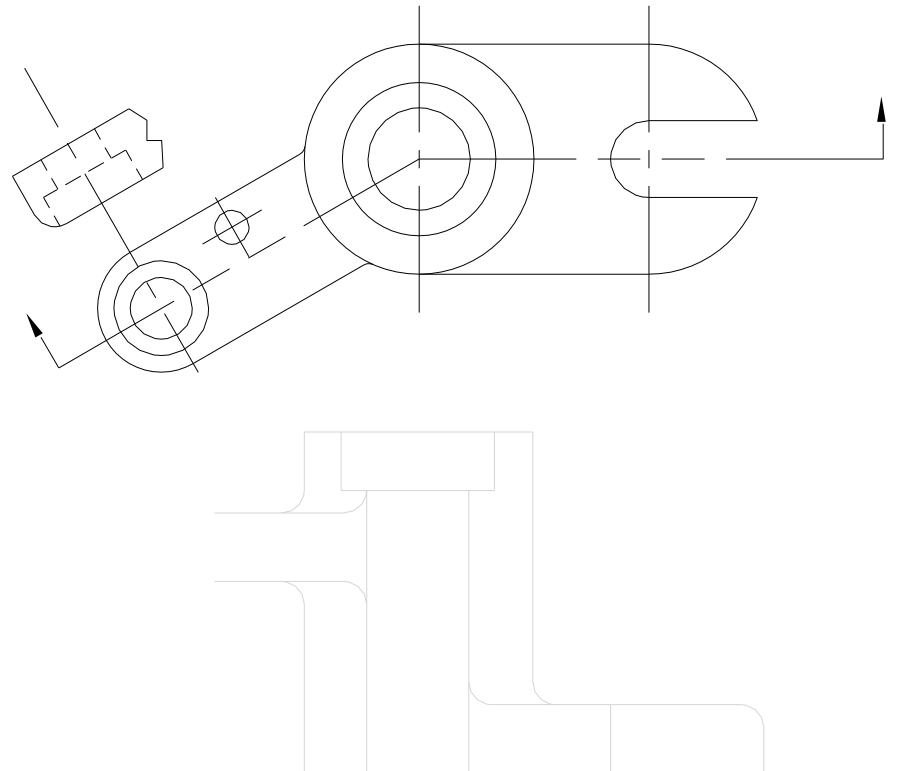

The top view of the Throttle Body is given.
Draw the full sectional front view using the guide in
dotted line and the auxiliary view for height details.
Follow the conventions of drawing sectional views.

