

--Question 1

- a) Using Boolean Algebra, minimize the following function (step by step):
- $F(A,B,C) = A' + AB + (A' + B)(A + B')$;
 - $F = BC + AC + A'B'C$ (4marks)
- b) List all possible **prime implicants** and **essential prime implicants** for Function F:
 $F = \sum(0, 2, 6, 7, 10, 13, 14, 15)$ with don't care conditions $d = \sum(1, 3, 12)$.
 Show groupings on a **Karnaugh map** accompanied with their algebraic forms. (3 marks)
- c) A circuit of Fig. 1 has been designed by an inexperienced engineer. Re-design the circuit, by Express P and Q in Fig. 1 as function of A, B and C and then produce an optimized circuit. (3 marks)

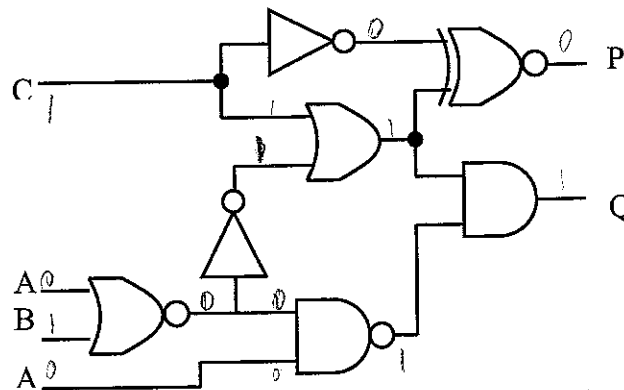

Fig. 1

--Question 2

2.1 Express function F

$F = AB + A'B'$ with:

- NAND-NAND
- NOR-NOR
- AND-OR-INV
- OR-AND-INV

Show the different steps and the logic diagram. (6 marks)

2.2 Consider the circuit in Fig. 2. Draw the **timing diagram** of F when input A, goes from 0 to 1 → 0 → 1 → 0. Indicate all timings on the diagram. (4 Marks)

Assume delay of Inverter = 3 ns and delay of NAND = 5 ns

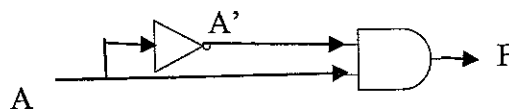

Fig. 2

--Question 3

a) Design a Circuit to give $F = A^3$.

A is a 2-bit unsigned binary number. $A = a_1a_0$.

(6 marks)

b) Use 2 to 4 decoder plus OR gates to implement F.

(4 marks)

--Question 4

- a) What is the difference between ROM, PROM, PAL, and the PLA. (2 marks)
 b) A designed sequential circuit is to be implemented using **2 JK Flip Flops and a PLA**. The excitation equations are:

$$J_A = Bx' \quad K_A = Bx$$

$$J_B = x \quad K_B = (A \oplus x)$$

Where A and B are the present states and x is an external input. Implement the circuit, with a PLA. Give, personality matrix and showing your programming of the PLA by placing a • on the programmable nodes. (5 marks)

- c) Implement the following function F, using only 2 to 1 multiplexers: (3marks)
 $F = A + B + ACD$

Question 5

Design a synchronous counter that generates the odd numbers between 0 and 10. (1,3,5,7,9) repeatedly and to generate an output of "1" corresponding to the number 9.

- 1) Draw the State Diagram.
- 2) Use binary state assignment, derive the State Transition Table.
- 3) Using D flip flops, derive the excitation equations.
- 4) Draw the sequential circuit diagram. (10 marks)

--Question 6

The circuit in Figure 3 has been designed to perform certain function. Analyze the circuit. Derive the state transition table and state diagram including all inputs and outputs. (10 marks)

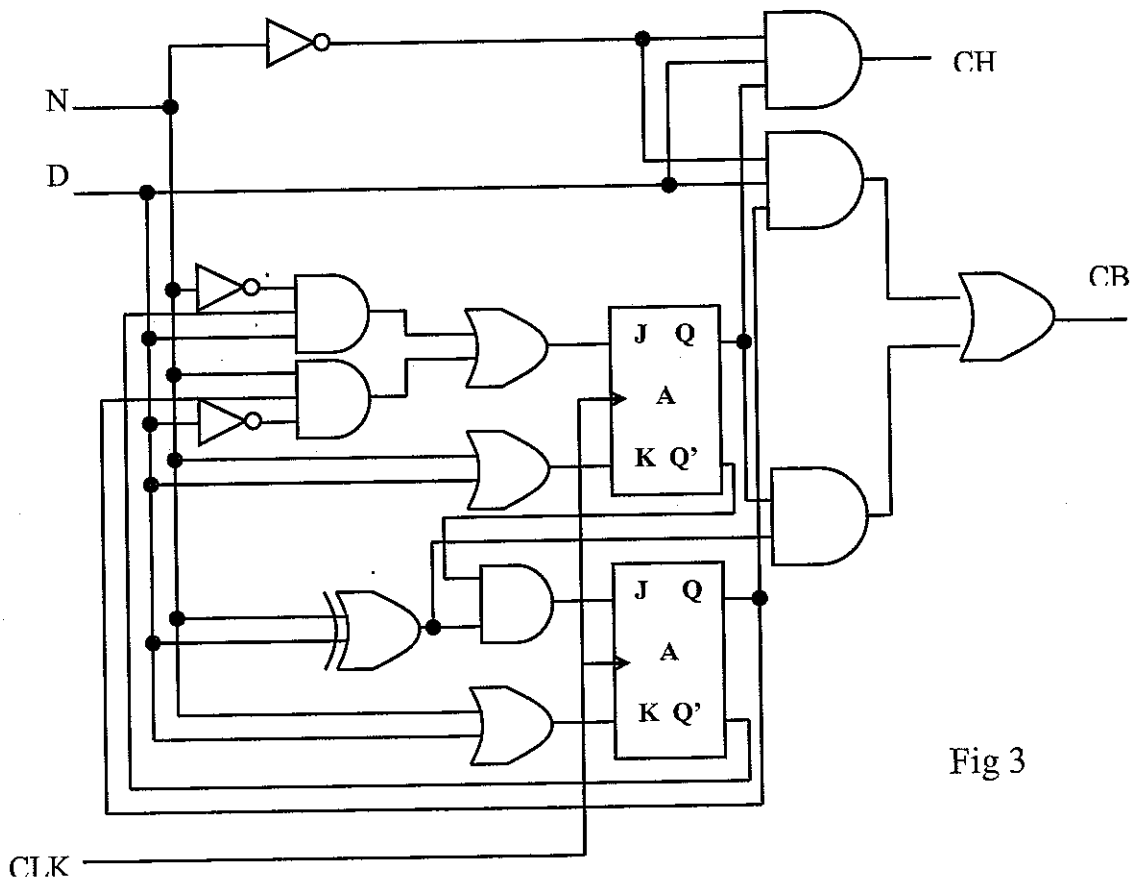

Fig 3

P1

Question 1:

a) i) $F(A, B, C) = \bar{A} + AB + (\bar{A} + B)(A + \bar{B})$
 $= \bar{A} + AB + \bar{A}\bar{B} + AB$
 $= \bar{A}(1 + \bar{B}) + AB$
 $= \bar{A} + AB$
 $= (\bar{A} + A)(\bar{A} + B)$

$F(A, B, C) = \bar{A} + B$

2/2

ii) $F = BC + AC + \bar{A}\bar{B}C$
 $= (A + \bar{A})BC + (B + \bar{B})AC + \bar{A}\bar{B}C$
 $= ABC + \bar{A}BC + ABC + \bar{A}\bar{B}C + \bar{A}\bar{B}C$
 $= ABC + \bar{A}C(B + \bar{B}) + AC(B + \bar{B})$
 $= ABC + \bar{A}C + AC$
 $= AC(B + 1) + \bar{A}C$
 $= AC + \bar{A}C$
 $= C(A + \bar{A})$

$F = C$

4/2

b)

	A		
C \ B	00	01	11 10
00	1 ₀		X ₁₂
01	X ₁	5	1 ₁₃
11	X ₃	1 ₉	1 ₁₅
10	1 ₂	1 ₆	1 ₁₄ 1 ₁₀

$EPI_1: \Sigma(0, 1, 2, 3) = \bar{A}$

$EPI_2: \Sigma(12, 13, 14, 15) =$

$EPI_3: \Sigma(2, 6, 10, 14) =$

$PI_4: \Sigma(6, 7, 14, 15) = B$

$PI_5: \Sigma(2, 3, 6, 7) = \bar{A}$

$F = \bar{A}\bar{B} + AB + C\bar{D} + \begin{cases} BC \\ \bar{A}C \end{cases}$

3/3

Q1 P2 COEN 312 Dec 2010

$$c) P = \bar{C} \odot (C + (\overline{A+B}))$$

$$Q = (C + (\overline{A+B})) (\overline{A(A+B)})$$

$$P = \bar{C} \odot (A+B+C)$$

$$= \bar{C}(A+B+C) + C(\overline{A+B+C})$$

$$= A\bar{C} + B\bar{C} + C(\bar{A}\bar{B}\bar{C})$$

$$P = \underline{A\bar{C} + B\bar{C}}$$

$$Q = (C+A+B) (\overline{A(\bar{A}\bar{B})})$$

$$= (C+A+B) (\bar{A} + (\overline{\bar{A}\bar{B}}))$$

$$= (A+B+C) (\bar{A} + A + B)$$

$$= (A+B+C) (1+B)$$

$$Q = \underline{A+B+C}$$

3/3

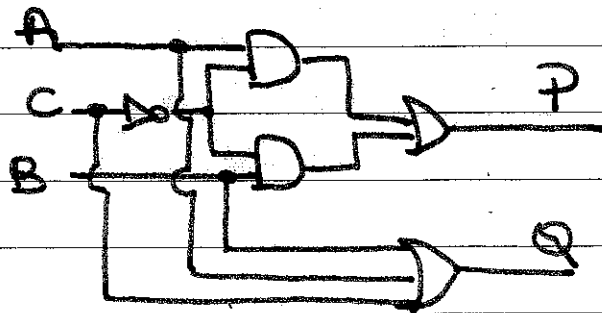

Question 2:

2.1) $F = AB + \overline{AB}$

i) $F = \overline{\overline{AB + \overline{AB}}}$

$F = (\overline{AB})(\overline{\overline{AB}})$

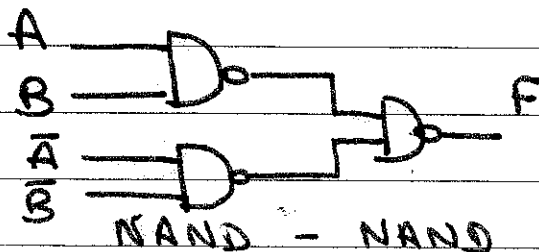

ii) $F = \overline{\overline{AB + \overline{AB}}}$
 $= \overline{(\overline{AB})(\overline{\overline{AB}})}$
 $= \overline{(\overline{A+B})(A+B)}$

$= \overline{\overline{AB} + AB}$
 $F = (\overline{A+B}) + (\overline{\overline{AB}})$

NOR - NOR

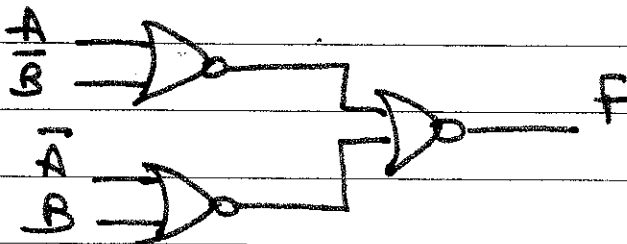

iii) $F = \overline{(\overline{A+B}) + (\overline{\overline{AB}})}$

$= \overline{(\overline{A+B})(\overline{\overline{AB}})}$

$F = \overline{\overline{AB} + AB}$

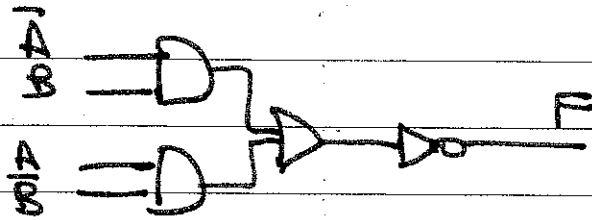

iii) $F = \overline{(\overline{A+B}) + (\overline{A+B})}$
 $F = \overline{(\overline{A+B})(\overline{A+B})}$

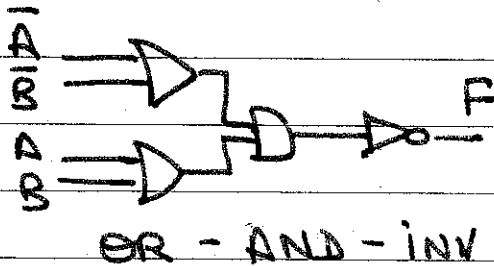

2.2)

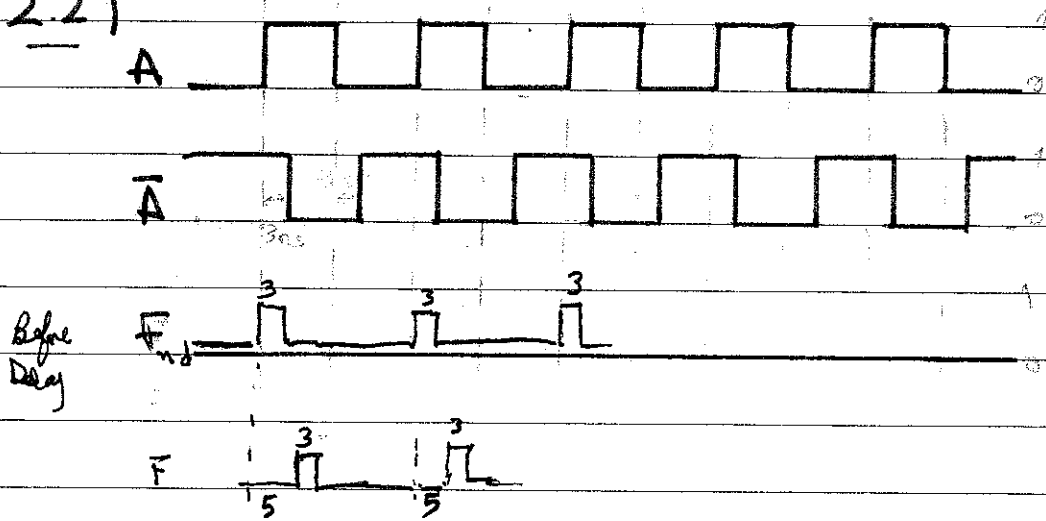

Question 3:

a) $F = A^3$

A		F				
a_1	a_0	b_4	b_3	b_2	b_1	b_0
0	0	0	0	0	0	0
0	1	0	0	0	0	1
1	0	0	1	0	0	0
1	1	1	1	0	1	1

$b_4 = a_1 a_0$

$b_3 = a_1$

$b_2 = 0$

$b_1 = b_4 = a_1 a_0$

$b_0 = a_0$

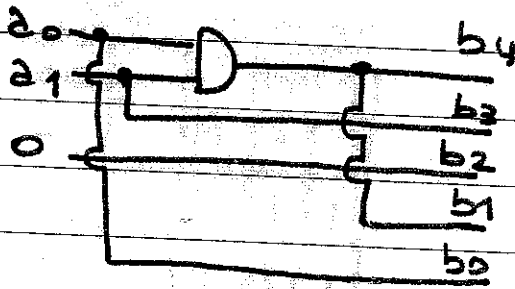

b)

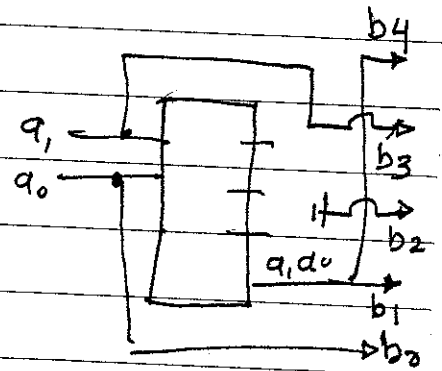
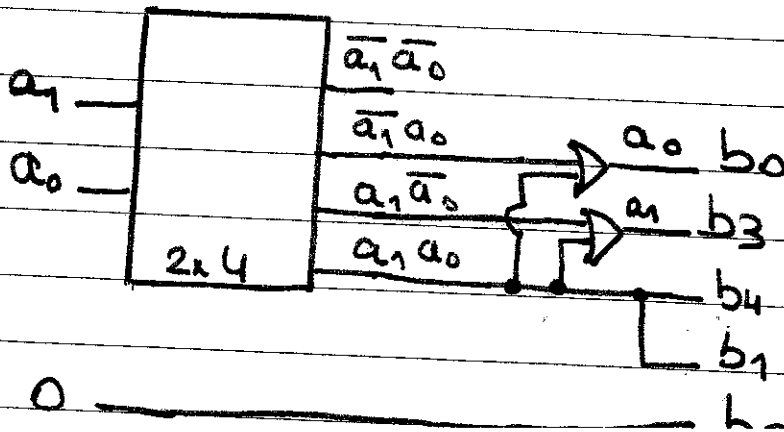

Q4 P1 COEN 31 Dec 2010

Question 4

- a) ROM: AND fixed OR fixed
 PROM: AND fixed OR programmable
 PAL: AND programmable OR fixed
 PLA: AND programmable OR programmable

b) $J_A = Bx'$ $K_A = Bx$
 $J_B = x$ $K_B = A \oplus x = A'x + Ax'$

A	B	x	AND			OR			
			A	B	x	J_A	J_B	K_A	K_B
0	0	0	1	1	1	-	-	1	-
0	0	1	2	0	1	-	-	-	1
0	1	0	3	1	0	1	-	-	-
0	1	1	4	-	1	-	1	-	-
1	0	0	5	1	0	$B'x$	x	Bx	$A \oplus x$
1	0	1							
1	1	0							
1	1	1							

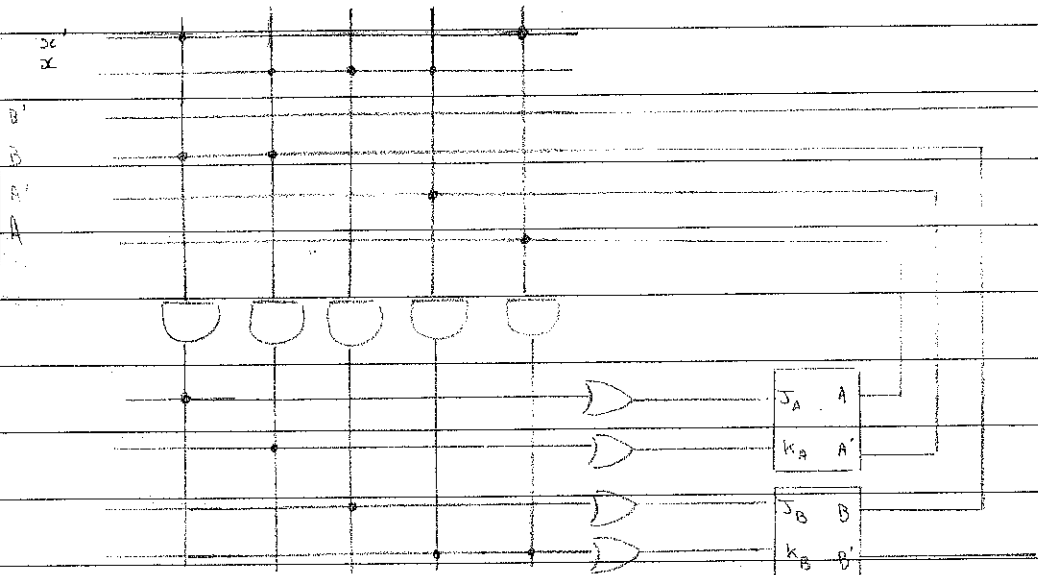

Q4 P2 COEN 31 Dec 2010

c) $F = A+B + ACD = B + A(1+CD) = A+B$

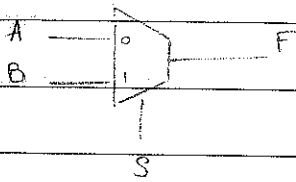

A	B	S	F
0	0	0	0
0	0	1	0
0	1	0	0
0	1	1	1
1	0	0	1
1	0	1	0
1	1	0	1
1	1	1	1

S	AB			
	00	01	11	10
0	0	0	1	0
1	0	1	0	0

$F = S'A + SB$

$$\left. \begin{array}{l} \text{If } S=0 \quad F=A \\ \text{If } S=1 \quad F=B \end{array} \right\} F=A+B$$

Question 5

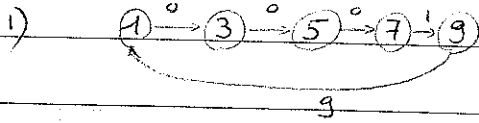

2) Present state Next state output

	m_3	m_2	m_1	m_0	m_3^+	m_2^+	m_1^+	m_0^+	output
0	0	0	0	1	0	0	1	1	0
1	X	X	X	X	X	X	X	X	X
2	0	0	1	1	0	1	0	1	0
3	X	X	X	X	X	X	X	X	X
4	0	1	0	1	0	1	1	1	0
5	X	X	X	X	X	X	X	X	X
6	0	1	1	1	1	0	0	1	0
7	X	X	X	X	X	X	X	X	X
8	1	0	0	1	0	0	0	1	1

(representing even numbers & numbers ≥ 10)

others don't care

3)

m_3	m_2	m_1	m_0	00	01	11	10
00	X	X	X	X			
01	0	0	X	0			
11	0	1	X	X			
10	X	X	X	X			

$m_3^+ = D_3$

m_3	m_2	m_1	m_0	00	01	11	10
00	X	X	X	X			
01	0	1	X	0			
11	1	0	X	X			
10	X	X	X	X			

m_2^+

For a D flip flop $Q^+ = D$

$m_3^+ = m_2 m_1 = D_3$

$m_2^+ = m_2 m_1' + m_2' m_1 = m_2 \oplus m_1 = D_2$

$m_1^+ = m_3' m_1'$

$m_0^+ = 1$

m_3	m_2	m_1	m_0	00	01	11	10
00	X	X	X	X			
01	0	1	X	0			
11	1	0	X	X			
10	X	X	X	X			

m_0

Q3 P2 COEN 3/2 Dec 2010

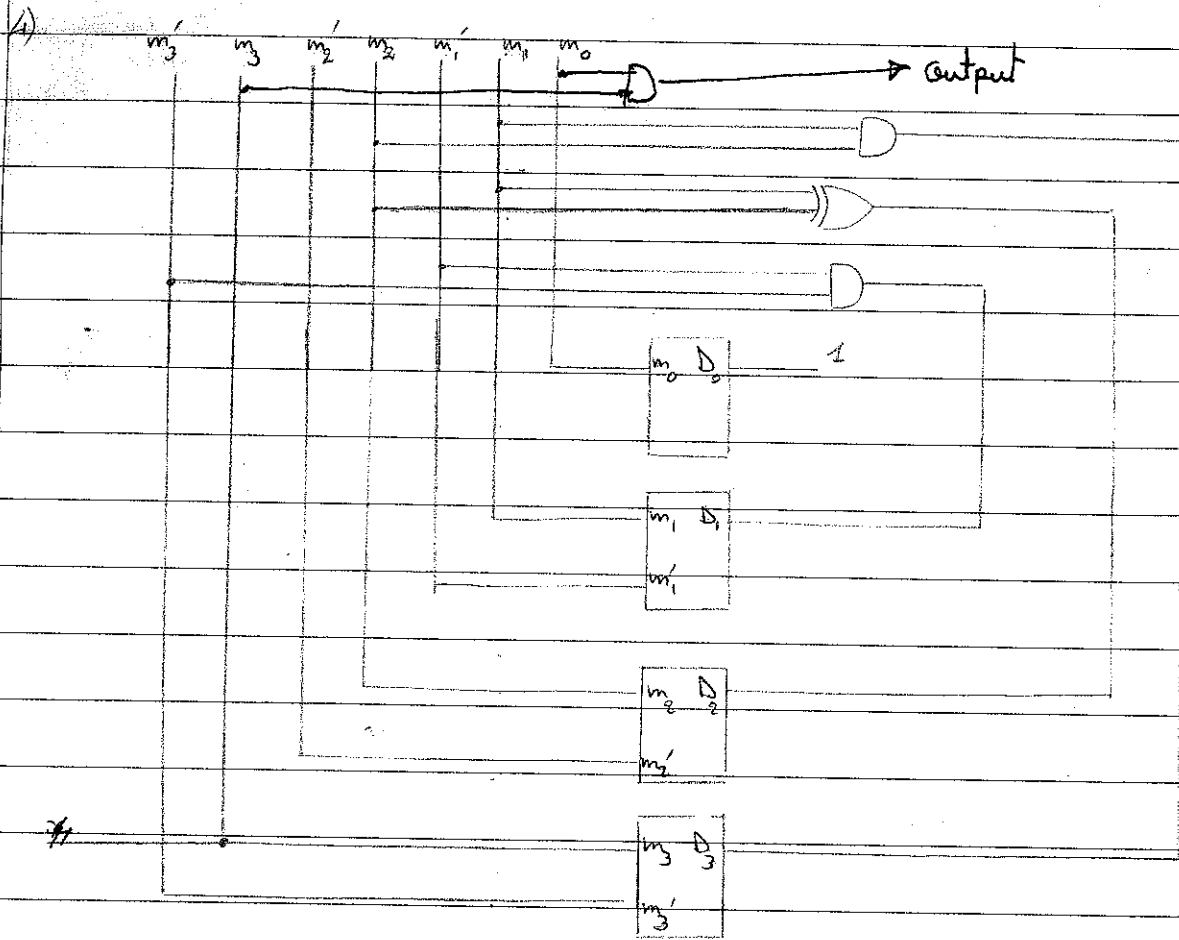

COEN312 Dec 2010

Question 6:

$$J_{A1} = \overline{N} \overline{Q_{A2}} D + N Q_{A2} \overline{D}$$

$$K_{A1} = N + D$$

$$\begin{aligned} \overline{K_A} &= \overline{(N+D)} \\ &= \overline{N} \overline{D} \end{aligned}$$

$$J_{A2} = \overline{Q_{A1}} (N \oplus D)$$

$$K_{A2} = N + D$$

$$Q^+ = J \overline{Q} + \overline{K} Q$$

$$Q_{A1}^+ = J_{A1} \overline{Q_{A1}} + \overline{K_{A1}} Q_{A1}$$

$$\underline{Q_{A1}^+ = (\overline{N} \overline{Q_{A2}} D + N Q_{A2} \overline{D}) \overline{Q_{A1}} + (\overline{N} \overline{D}) Q_{A1}}$$

$$Q_{A2}^+ = J_{A2} \overline{Q_{A2}} + \overline{K_{A2}} Q_{A2}$$

$$\underline{Q_{A2}^+ = (\overline{Q_{A1}} (N \oplus D)) \overline{Q_{A2}} + (\overline{N} \overline{D}) Q_{A2}}$$

$$\underline{CH = Q_{A1}^+ D \overline{N}}$$

$$\underline{CB = \overline{N} D Q_{A2}^+ + Q_{A1}^+ (N \oplus D)}$$

Q6 - P2 ~~CON 3/2~~ Dec 2010

Inputs		Present State		Next State		Outputs	
N	D	Q_{A1}	Q_{A2}	Q_{A1}^+	Q_{A2}^+	CH	CB
0	0	0	0	0	0	0	0
0	0	0	1	0	1	0	0
0	0	1	0	1	0	0	0
0	0	1	1	1	1	0	0
0	1	0	0	1	1	1	1
0	1	0	1	0	0	0	0
0	1	1	0	0	0	0	0
0	1	1	1	0	0	0	0
1	0	0	0	0	1	0	1
1	0	0	1	1	0	0	1
1	0	1	0	0	0	0	0
1	0	1	1	0	0	0	0
1	1	0	0	0	0	0	0
1	1	0	1	0	0	0	0
1	1	1	0	0	0	0	0
1	1	1	1	0	0	0	0

