



MCG 2108 A Mechanics II (Fall 2015)

FINAL Examination

21st December, 2015

Time allowed: 3 hrs

Pg: 1/3

Total Points: 50

PLEASE READ INSTRUCTIONS CAREFULLY:

-
- *Write clearly and must make DIGRAMS where necessary.*
 - *Non-Programmable Calculators permitted.*
 - *Attempt All Four questions (There is a choice between Question 1).*
 - *Return the Question paper with the Answer booklet & FORMULA SHEET.*

Q1:

(12.5 points)

Two cars of the same mass run head-on into each other at C . After the collision, the cars skid with their brakes locked and come to a stop in the positions shown in the lower part of the figure. Knowing that the speed of the car A just before the impact was 8 km/hr and that the coefficient of kinetic friction between the pavement and the tires of both cars is 0.30 , determine (a) the speed of the car B just before impact, (b) the effective coefficient of restitution between the two cars.

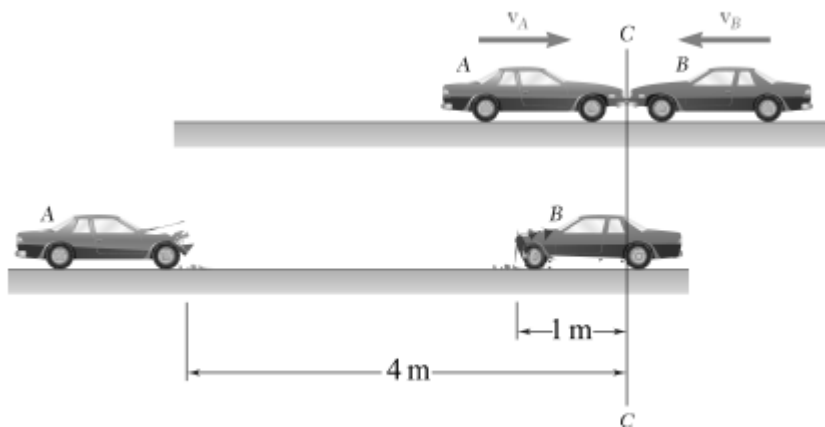

OR

Q1:

(12.5 points)

A 20 - kg block B is suspended from a 2-m cord attached to a 30 - kg cart A which may roll freely on a frictionless horizontal track. If the system is released from rest as shown in the position below, determine the velocities of A and B as B passes directly under A .

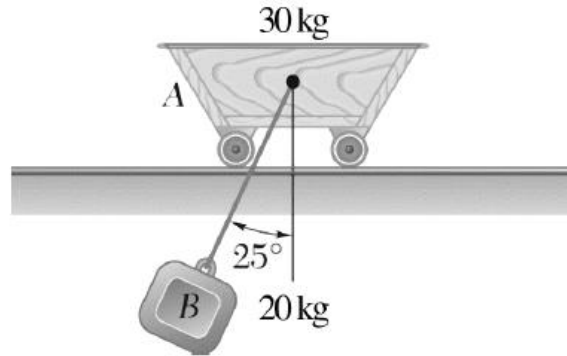

Q2:

(12.5 points)

The 200 mm radius disk rolls without sliding on the surface shown. Knowing that the distance BG is 160 mm and that at the instant shown the disk has an angular velocity of 8 rad/s counterclockwise and an angular acceleration of 2 rad/s² clockwise, determine:

- the angular velocity of bar AB (ω_{AB});
- the acceleration of point B (in component form);
- the angular acceleration of bar AB (α_{AB});
- the acceleration of point A .

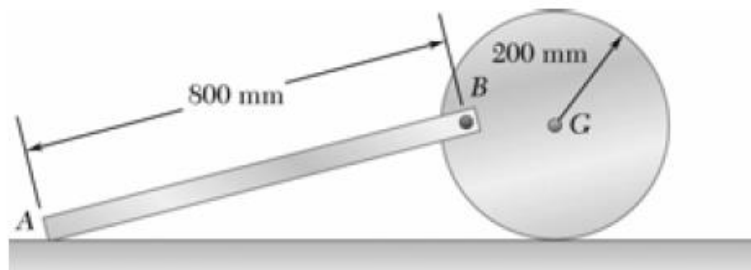

Q3:

(12.5 points)

The motion of the uniform rod AB of mass 8 kg and length $L = 900\text{ mm}$ is guided by small wheels of negligible mass that roll on the surface shown. If the rod is released from rest when $\theta = 20^\circ$, determine:

- the angular acceleration of the rod;
- the reaction force at A .

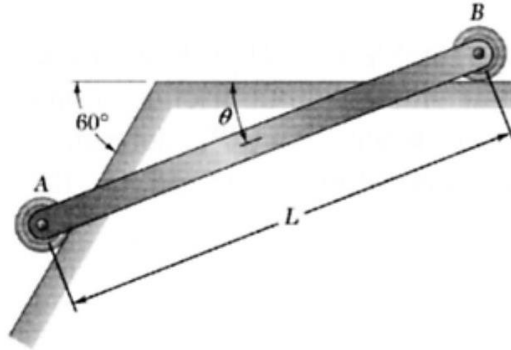

Q4:

(12.5 points)

The 4 kg disk A has a radius $r_A = 150\text{ mm}$ and is initially at rest. The 5 kg disk B has a radius $r_B = 200\text{ mm}$ and an angular velocity ω_0 of 900 rpm when it is brought in contact with disk A . Neglecting friction in the bearing, determine (a) the final angular velocity of each disk, (b) the total impulse of the friction force exerted on disk A .

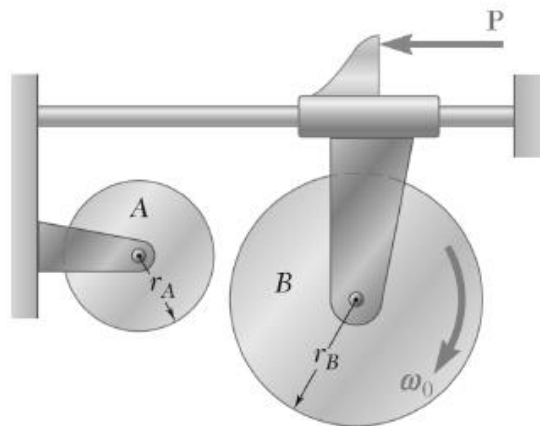

GOOD LUCK !