

CONCORDIA UNIVERSITY

Faculty of Engineering and Computer Science  
ENGR 242/4 Statics, Section J  
Test #2

MARKS Attempt all questions, only calculators permitted

TIME: 70 Minutes

- 30 1) The uniform 15-m pole has a mass of 150 kg and is supported by its smooth ends against the vertical walls and by the tension  $T$  in the vertical cable. Compute the reactions at A and B.

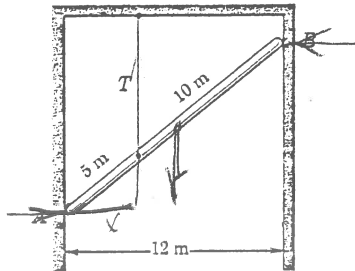

- 40 2) A rectangular box is supported by balls and sockets at A and E and by a roller on a horizontal surface at B. Determine the reaction at B when a 60-lb vertical force is applied at the midpoint D of edge CE, as shown.

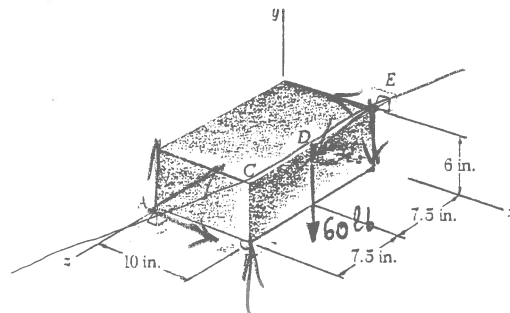

- 30 3) The spring-loaded vertical gate is hinged about a horizontal axis along its upper edge A and closes the end of a rectangular fresh-water channel 1.2 m wide (normal to the plane of the paper). Calculate the preset spring force  $F$  that will limit the depth of the water to  $h = 1.8$  m.

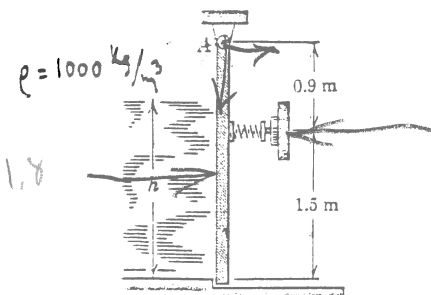

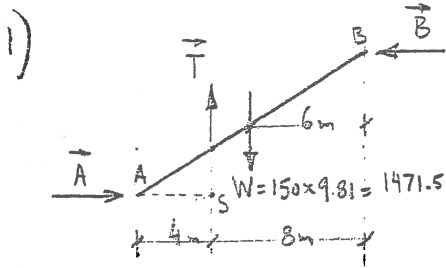

$$\sum M_S = 0 = W \times 2 - B \times 9 \Rightarrow \underline{\underline{B = \frac{1471.5 \times 2}{9} = 327 \text{ N}}}$$

$$\sum F_x = 0 = A - B \Rightarrow \underline{\underline{A = B = 327 \text{ N}}}$$

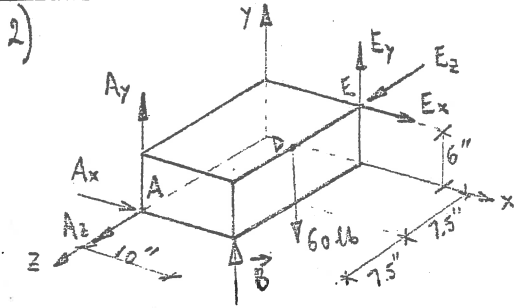

$$\vec{\lambda}_{AE} = \frac{10\vec{i} + 6\vec{j} - 15\vec{k}}{\sqrt{10^2 + 6^2 + 15^2}} = 0.526\vec{i} + 0.316\vec{j} - 0.789\vec{k}$$

$$\begin{aligned} \sum M_{AE} = 0 &= \vec{\lambda}_{AE} \cdot (\vec{r}_{AB} \times \vec{B} + \vec{r}_{ED} \times [-60\vec{j}]) = \\ &= (0.526\vec{i} + 0.316\vec{j} - 0.789\vec{k}) \cdot (10\vec{i} \times B\vec{j} + 7.5\vec{k} \times (-60\vec{j})) = \\ &= (0.526\vec{i} + 0.316\vec{j} - 0.789\vec{k}) \cdot (10B\vec{k} + 450\vec{i}) = \\ &= 236.7 - 7.89B \Rightarrow \underline{\underline{B = 30 \text{ lb}}} \end{aligned}$$

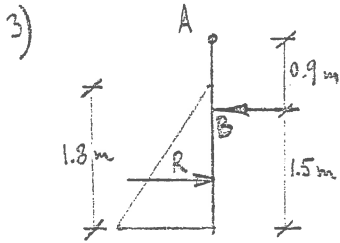

$$R = \frac{1}{2} \times 1.8 \times (9.81 \times 1.0 \times 1.8) \times 1.2 = 19.07 \text{ kN}$$

$$\sum M_A = 0 = 19.07 (2.4 - 0.6) - B \times 0.9 \Rightarrow \underline{\underline{B = 38.14 \text{ kN}}}$$

ONCE MORE : LEARN FROM YOUR MISTAKES !