

Chapter 8: Subnetting IP networks

Introduction to Networks v5.1

Marvin Krym



Chapter Outline

8.0 Introduction

8.1 Subnetting an IPv4 Network

8.2 Addressing Schemes

8.3 Design Considerations for
IPv6

8.4 Summary

Section 8.1:

Subnet an IPv4 Network

Upon completion of this section, you should be able to:

- Explain how subnetting segments a network to enable better communication.
- Explain how to calculate IPv4 subnets for a /24 prefix.
- Explain how to calculate IPv4 subnets for a /16 and /8 prefix.
- Given a set of requirements for subnetting, implement an IPv4 addressing scheme.
- Explain how to create a flexible addressing scheme using variable length subnet masking (VLSM).

Topic 8.1.1: Network Segmentation



Broadcast Domains

Each router interface connects a *broadcast domain* and broadcasts are only propagated within its specific broadcast domain.

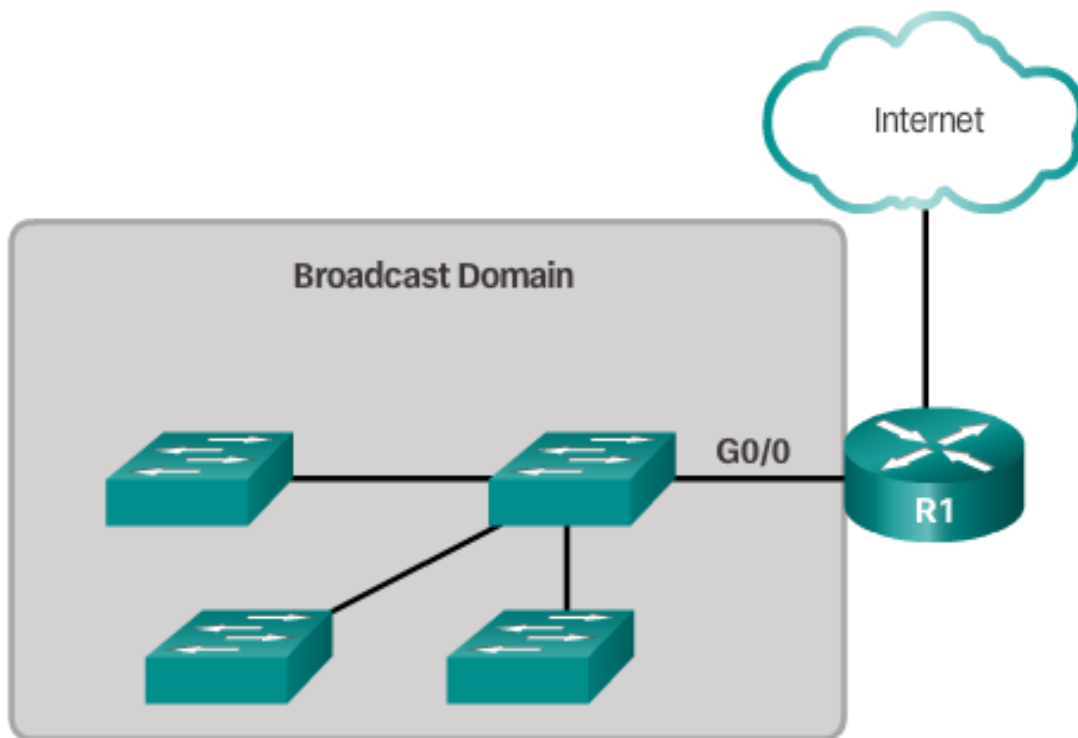

Problems with Large Broadcast Domains

- Slow network operations due to the significant amount of broadcast traffic.
- Slow device operations because a device must accept and process each broadcast packet.

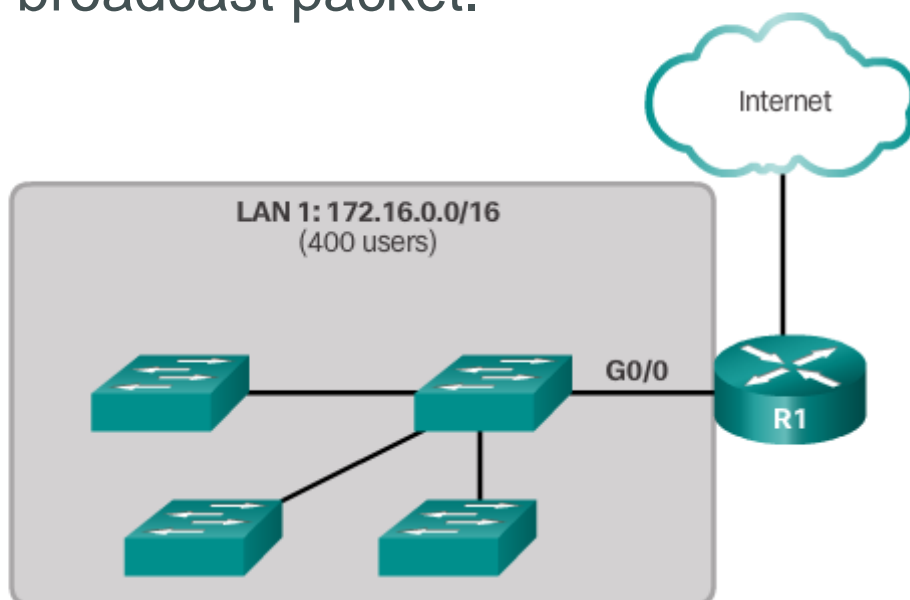

Problems with Large Broadcast Domains (cont.)

- Solution -reduce the size of the network to create smaller broadcast domains in a process called *subnetting*.
- These smaller network spaces are called *subnets*.

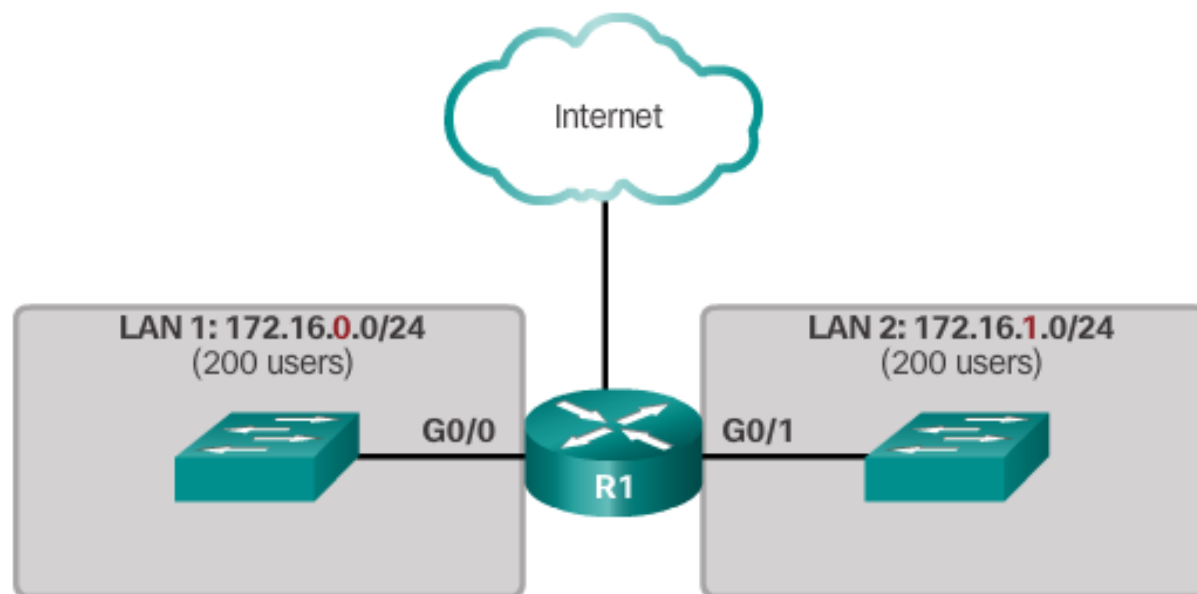

Reasons for Subnetting

Network administrators can group devices and services into subnets that are determined by: Location

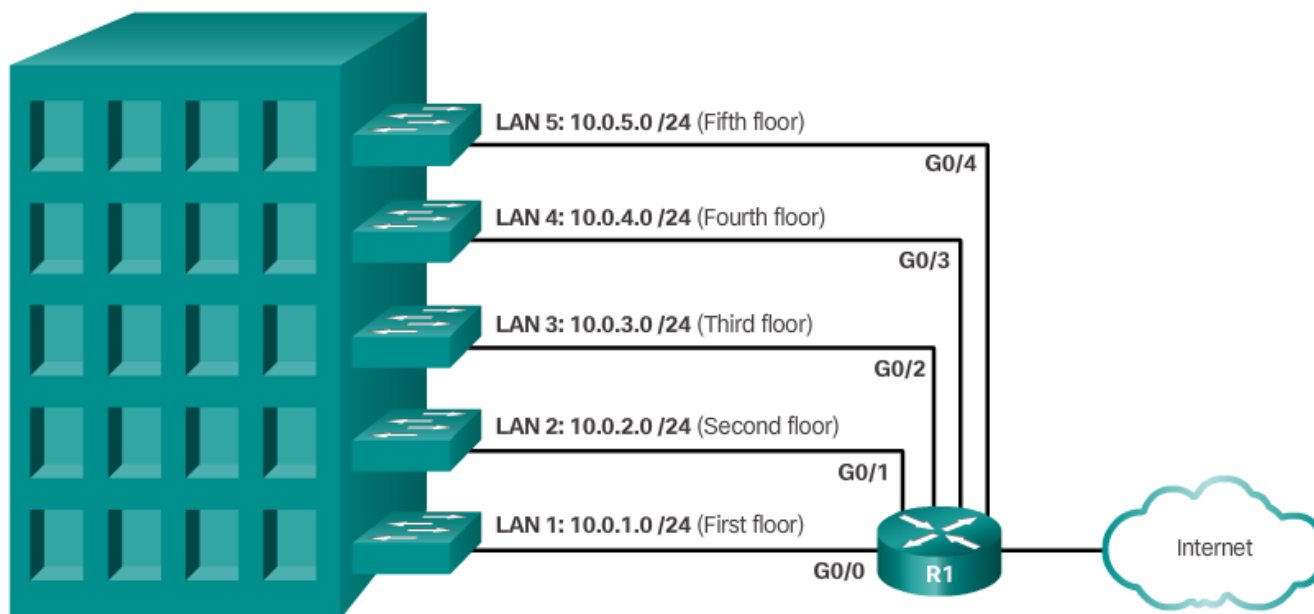

Reasons for Subnetting (cont.)

Network administrators can group devices and services into subnets that are determined by: Organizational unit.

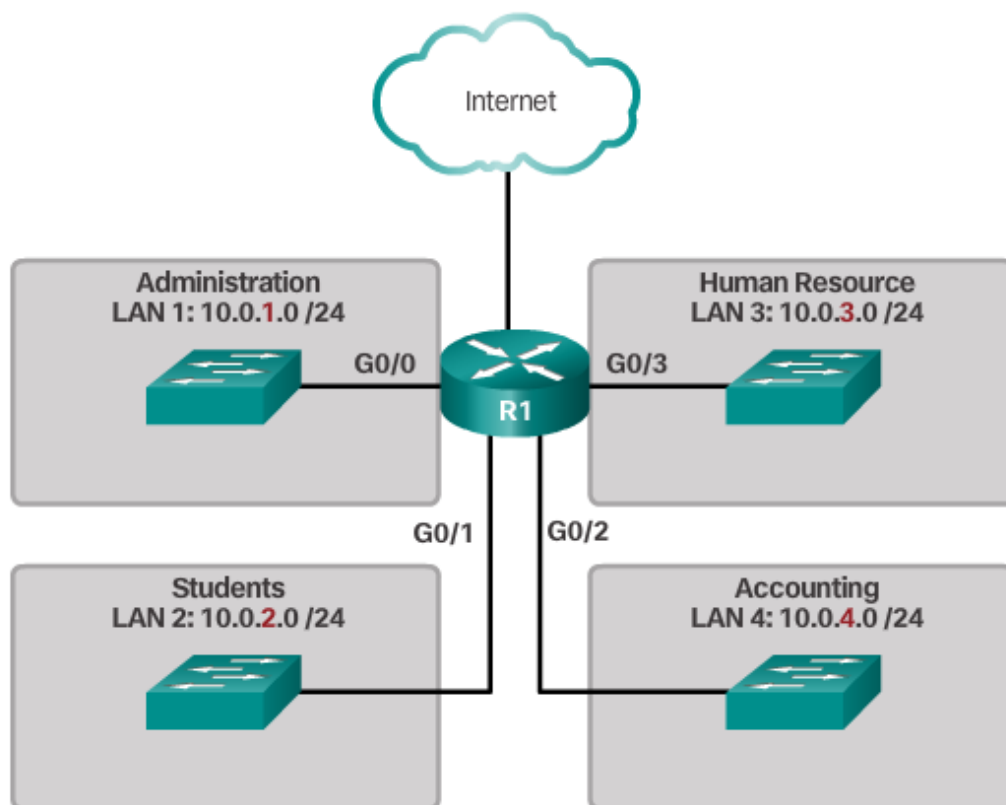

Reasons for Subnetting (cont.)

Network administrators can group devices and services into subnets that are determined by: Device type.

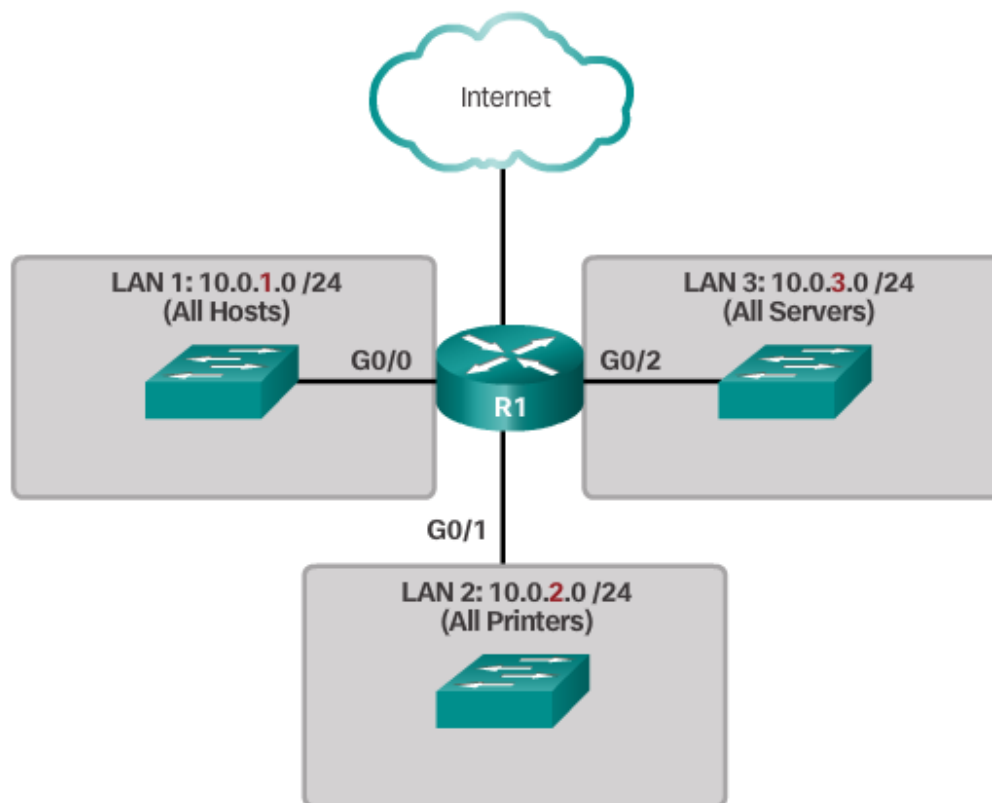

Topic 8.1.2: Subnetting an IPv4 Network



Subnet a Network Address

Method:

Borrowing host bits and turning them into network bits.

Example:

Network Address:
Provided by network ISP

172.16.0.0/16
network host

Subnetted Address:
Eight bits are borrowed to
increase the number of
network bits

172.16.0.0/24
network subnet host

A Note About IP Addresses

IP Address in
Human Readable
Format

172.16.15.10/24

10101100000100000000111100001010

IP Address in
Network Computer Readable Format

Dots are added only to made IP addresses readable by people.
Subnet Arithmetic needs to be done per octet.

Octet Boundaries

Subnetting Networks on the Octet Boundary

Prefix Length	Subnet Mask	Subnet Mask in Binary (n = network, h = host)	# of hosts
/8	255.0.0.0	<code>nnnnnnnn . hhhhhhhh . hhhhhhhh . hhhhhhhh 11111111 . 00000000 . 00000000 . 00000000</code>	16,777,214
/16	255.255.0.0	<code>nnnnnnnn . nnnnnnnn . hhhhhhhh . hhhhhhhh 11111111 . 11111111 . 00000000 . 00000000</code>	65,534
/24	255.255.255.0	<code>nnnnnnnn . nnnnnnnn . nnnnnnnn . hhhhhhhh 11111111 . 11111111 . 11111111 . 00000000</code>	254

Class B IP Address Subnet Example

Network Address: **172.16.0.0/16**
Provided by network ISP

Borrow 8 bits from host
for subnet to create /24 **172.16.0.0/24**

Specific Subnets

172.16.0.0/24

172.16.1.0/24

172.16.2.0/24

172.16.255.0/24



Class B IP Address Subnet Example cont'd

Specific Subnets

s=8; no. of subnets=256

172.16.0.0/24

172.16.1.0/24

172.16.2.0/24



172.16.255.0/24

2^s Subnets
s: # subnet bits

Host Addresses per Subnet

h=8; no. of hosts=254

172.16.5.1

172.16.5.2

172.16.5.3



172.16.6.254

$2^h - 2$ Hosts
h: # host bits

Subnetting on the Octet Boundary

Subnetting 10.x.0.0/16

Subnet Address (256 Possible Subnets)	Host Range (65,534 possible hosts per subnet)	Broadcast
<u>10.0.0.0/16</u>	<u>10.0.0.1 - 10.0.255.254</u>	<u>10.0.255.255</u>
<u>10.2.0.0/16</u>	<u>10.2.0.1 - 10.2.255.254</u>	<u>10.2.255.255</u>
<u>10.3.0.0/16</u>	<u>10.3.0.1 - 10.3.255.254</u>	<u>10.3.255.255</u>
<u>10.4.0.0/16</u>	<u>10.4.0.1 - 10.4.255.254</u>	<u>10.4.255.255</u>
<u>10.5.0.0/16</u>	<u>10.5.0.1 - 10.5.255.254</u>	<u>10.5.255.255</u>
<u>10.6.0.0/16</u>	<u>10.6.0.1 - 10.6.255.254</u>	<u>10.6.255.255</u>
<u>10.7.0.0/16</u>	<u>10.7.0.1 - 10.7.255.254</u>	<u>10.7.255.255</u>
...
<u>10.255.0.0/16</u>	<u>10.255.0.1 - 10.255.255.254</u>	<u>10.255.255.255</u>

Subnetting 10.x.x.0/24

Subnet Address (65,536 Possible Subnets)	Host Range (254 possible hosts per subnet)	Broadcast
<u>10.0.0.0/24</u>	<u>10.0.0.1 - 10.0.0.254</u>	<u>10.0.0.255</u>
<u>10.0.1.0/24</u>	<u>10.0.1.1 - 10.0.1.254</u>	<u>10.0.1.255</u>
<u>10.0.2.0/24</u>	<u>10.0.2.1 - 10.0.2.254</u>	<u>10.0.2.255</u>
...
<u>10.0.255.0/24</u>	<u>10.0.255.1 - 10.0.255.254</u>	<u>10.0.255.255</u>
<u>10.1.0.0/24</u>	<u>10.1.0.1 - 10.1.0.254</u>	<u>10.1.0.255</u>
<u>10.1.1.0/24</u>	<u>10.1.1.1 - 10.1.1.254</u>	<u>10.1.1.255</u>
<u>10.1.2.0/24</u>	<u>10.1.2.1 - 10.1.2.254</u>	<u>10.1.2.255</u>
...
<u>10.100.0.0/24</u>	<u>10.100.0.1 - 10.100.0.254</u>	<u>10.100.0.255</u>
...
<u>10.255.255.0/24</u>	<u>10.255.255.1 - 10.255.255.254</u>	<u>10.255.255.255</u>

Classless Subnetting

- /25 – Borrowing 1 bit from the fourth octet creates 2 subnets supporting 126 hosts each.
- /26 – Borrowing 2 bits creates 4 subnets supporting 62 hosts each.
- /27– Borrowing 3 bits creates 8 subnets supporting 30 hosts each.
- /28 – Borrowing 4 bits creates 16 subnets supporting 14 hosts each.
- /29 – Borrowing 5 bits creates 32 subnets supporting 6 hosts each.
- /30– Borrowing 6 bits creates 64 subnets supporting 2 hosts each.

Prefix Length	Subnet Mask	Subnet Mask in Binary (n = network, h = host)	# of subnets	# of hosts
/25	255.255.255.128	nnnnnnnn . nnnnnnnn . nnnnnnnn . nhhhhhh 11111111 . 11111111 . 11111111 . 10000000	2	126
/26	255.255.255.192	nnnnnnnn . nnnnnnnn . nnnnnnnn . nhhhhhh 11111111 . 11111111 . 11111111 . 11000000	4	62
/27	255.255.255.224	nnnnnnnn . nnnnnnnn . nnnnnnnn . nnnhhhhh 11111111 . 11111111 . 11111111 . 11100000	8	30
/28	255.255.255.240	nnnnnnnn . nnnnnnnn . nnnnnnnn . nnnnhhhh 11111111 . 11111111 . 11111111 . 11110000	16	14
/29	255.255.255.248	nnnnnnnn . nnnnnnnn . nnnnnnnn . nnnnhhh 11111111 . 11111111 . 11111111 . 11111000	32	6
/30	255.255.255.252	nnnnnnnn . nnnnnnnn . nnnnnnnn . nnnnnhh 11111111 . 11111111 . 11111111 . 11111100	64	2

Classless IP Address Subnet Example

Network Address: 192.168.1.0/24
Provided by network ISP

Borrow 2 bits from host
for subnet to create /26

192.168.1.0/26

192.168.1. ss hhhhhh

network subnet host

binary

Specific Subnets
(4 subnets)

192.168.1.0/26	(ss=00)
192.168.1.64/26	(ss=01)
192.168.1.128/26	(ss=10)
192.168.1.192/26	(ss=11)

Classless IP Address Subnet Example

Specific Subnets
(4 subnets)

192.168.1.0/26

192.168.1.64/26

192.168.1.128/26

192.168.1.192/26

$2^2 = 4$ Subnets
s=2: # subnet bits

Host Addresses per
Subnet

172.16.1.65

172.16.1.66

172.16.1.67

172.16.1.126

$2^6 - 2 = 62$ Hosts
h=6: # host bits

Classless Subnetting Example

192.168.1.0/25 Network

Borrow 1 bit from the host portion of the address.

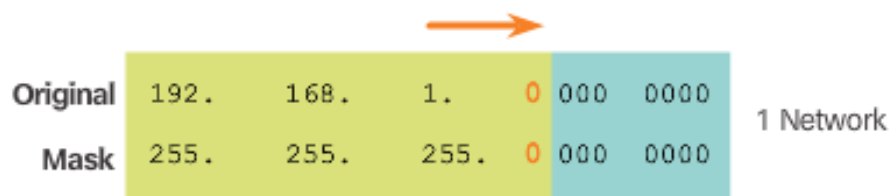

An orange arrow points from the right side of the original network address to the borrowed bit in the mask.

Original	192 .	168 .	1 .	0	000	0000	1 Network
Mask	255 .	255 .	255 .	0	000	0000	

The borrowed bit value is **0** for the Net 0 address.

Net 0	192 .	168 .	1 .	0	000	0000	2 Subnets
Net 1	192 .	168 .	1 .	1	000	0000	

The new subnets have the **SAME** subnet mask.

Mask	255 .	255 .	255 .	1	000	0000
-------------	-------	-------	-------	---	-----	------

Classless Subnetting Example (cont.)

Dotted Decimal Addresses

Borrow 1 bit from the host portion of the address.

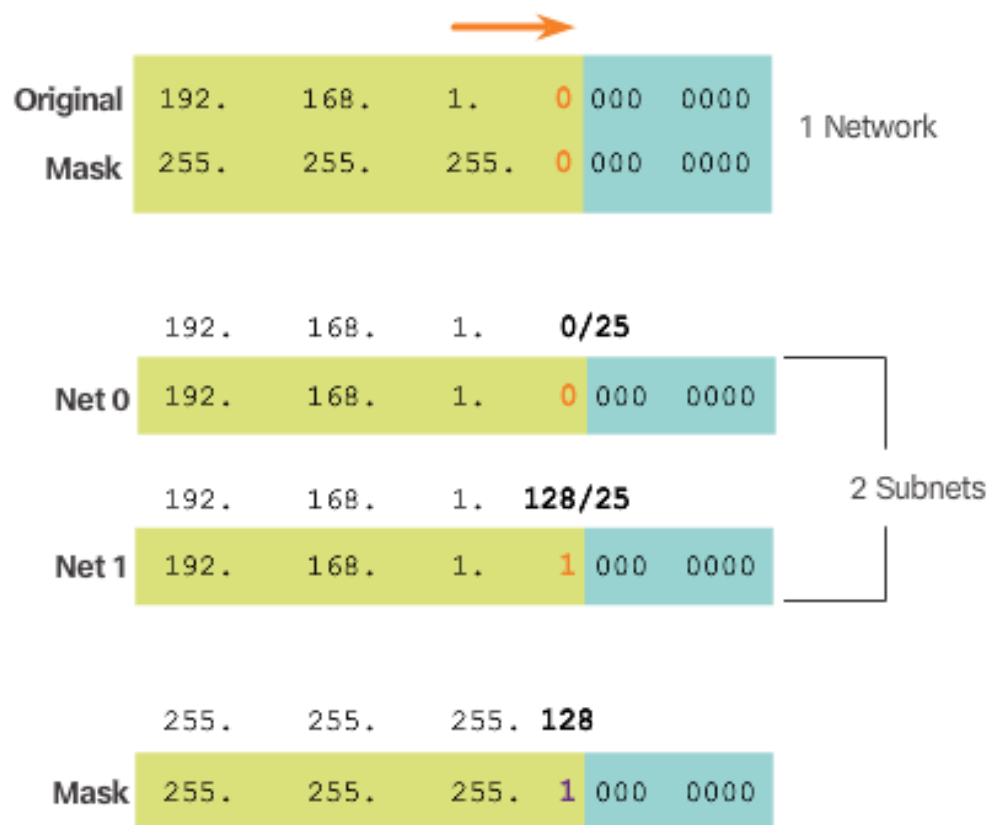

Creating 2 Subnets

/25 Subnetting Topology

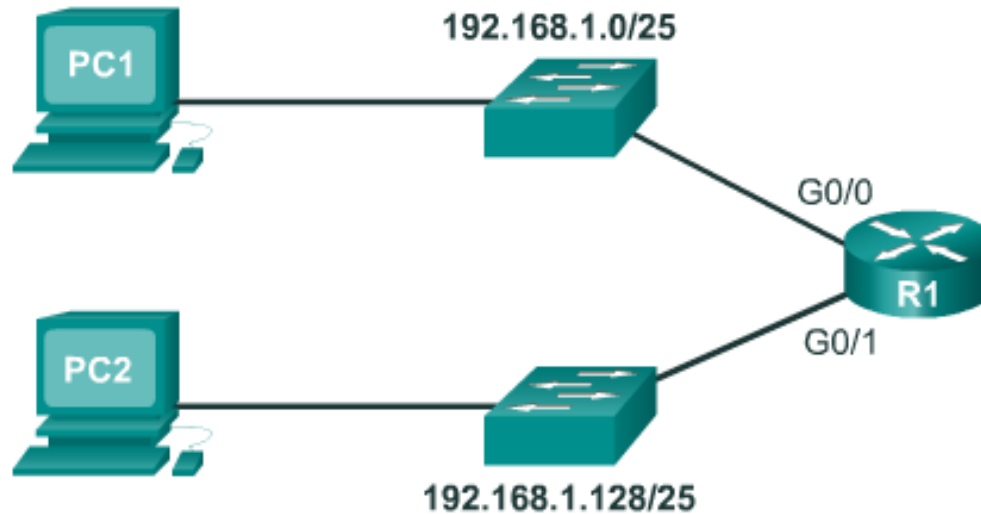

Creating 2 Subnets (cont.)

Address Range for 192.168.1.0/25 Subnet

Network Address

192. 168. 1. 0 000 0000 = 192.168.1.0

First Host Address

192. 168. 1. 0 000 0001 = 192.168.1.1

Last Host Address

192. 168. 1. 0 111 1110 = 192.168.1.126

Broadcast Address

192. 168. 1. 0 111 1111 = 192.168.1.127

Address Range for 192.168.1.128/25 Subnet

Network Address

192. 168. 1. 1 000 0000 = 192.168.1.128

First Host Address

192. 168. 1. 1 000 0001 = 192.168.1.129

Last Host Address

192. 168. 1. 1 111 1110 = 192.168.1.254

Broadcast Address

192. 168. 1. 1 111 1111 = 192.168.1.255

Creating 4 Subnets

/26 Subnetting Topology

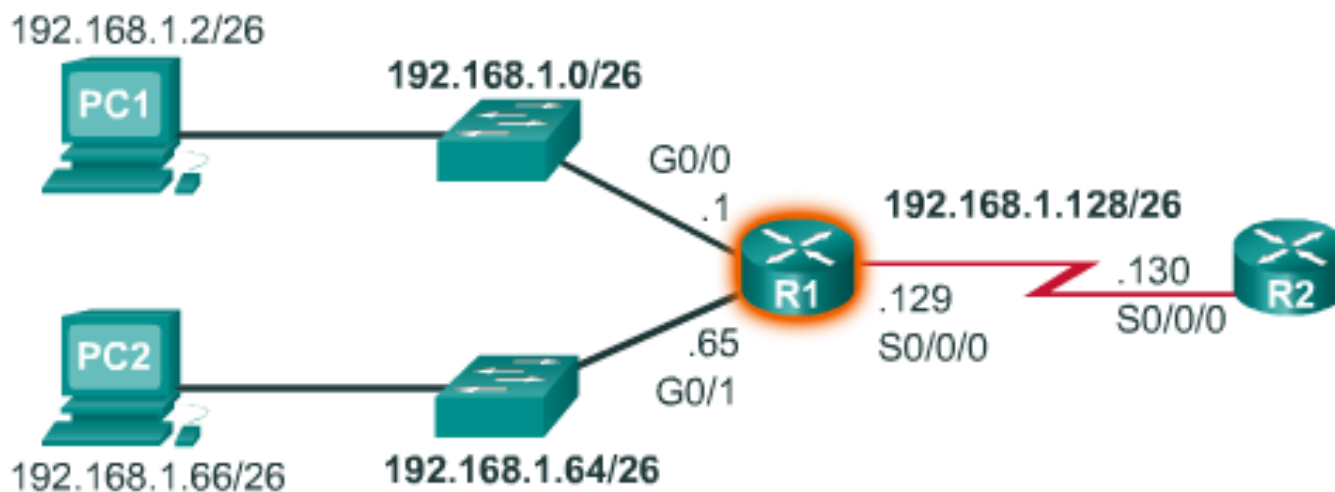

Creating 4 Subnets (cont.)

Borrowing 2 Bits

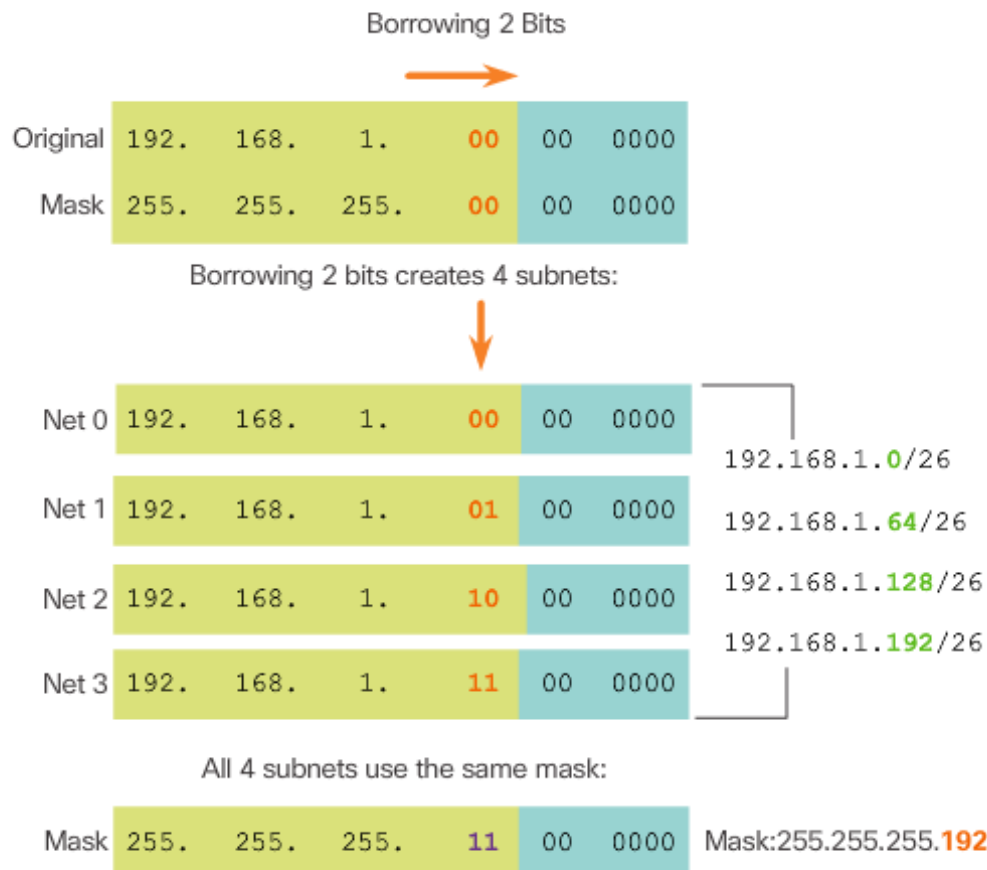

Creating 4 Subnets (cont.)

Calculate Number of Hosts

192. 168. 1. 00 00 0000

6 bits remain in host field

$2^6 = 64$ hosts per subnet
 $2^6 - 2 = 62$ valid hosts per subnet

Address Range for 192.168.1.0/26 Subnet

Network Address

192. 168. 1. 00 00 0000 = 192.168.1.0

First Host Address

192. 168. 1. 00 00 0001 = 192.168.1.1

Last Host Address

192. 168. 1. 00 11 1110 = 192.168.1.62

Broadcast Address

192. 168. 1. 00 11 1111 = 192.168.1.63

Creating 4 Subnets (cont.)

Address Ranges Nets 0 - 2

Net 0	Network	192.	168.	1.	00	00	0000	192.168.1.0
	First	192.	168.	1.	00	00	0001	192.168.1.1
	Last	192.	168.	1.	00	11	1110	192.168.1.62
	Broadcast	192.	168.	1.	00	11	1111	192.168.1.63
Net 1	Network	192.	168.	1.	01	00	0000	192.168.1.64
	First	192.	168.	1.	01	00	0001	192.168.1.65
	Last	192.	168.	1.	01	11	1110	192.168.1.126
	Broadcast	192.	168.	1.	01	11	1111	192.168.1.127
Net 2	Network	192.	168.	1.	10	00	0000	192.168.1.128
	First	192.	168.	1.	10	00	0001	192.168.1.129
	Last	192.	168.	1.	10	11	1110	192.168.1.190
	Broadcast	192.	168.	1.	10	11	1111	192.168.1.191

Topic 8.1.3: Subnetting a /16 and a /8 Prefix



Creating Subnets with a /16 prefix

Prefix Length	Subnet Mask	Network Address (n = network, h = host)	# of subnets	# of hosts
/17	255.255.128.0	nnnnnnnn.nnnnnnnn.nhhhhhhh.hhhhhhhh 11111111.11111111.10000000.00000000	2	32564
/18	255.255.192.0	nnnnnnnn.nnnnnnnn.nnhhhhhh.hhhhhhhh 11111111.11111111.11000000.00000000	4	16282
/19	255.255.224.0	nnnnnnnn.nnnnnnnn.nnnhhhhh.hhhhhhhh 11111111.11111111.11100000.00000000	8	8190
/20	255.255.240.0	nnnnnnnn.nnnnnnnn.nnnnhhhh.hhhhhhhh 11111111.11111111.11110000.00000000	16	4094
/21	255.255.248.0	nnnnnnnn.nnnnnnnn.nnnnnhhh.hhhhhhhh 11111111.11111111.11111000.00000000	32	2046
/22	255.255.252.0	nnnnnnnn.nnnnnnnn.nnnnnnhh.hhhhhhhh 11111111.11111111.11111100.00000000	64	1022
/23	255.255.254.0	nnnnnnnn.nnnnnnnn.nnnnnnnh.hhhhhhhh 11111111.11111111.11111110.00000000	128	510
/24	255.255.255.0	nnnnnnnn.nnnnnnnn.nnnnnnnn.hhhhhhhh 11111111.11111111.11111111.00000000	256	254
/25	255.255.255.128	nnnnnnnn.nnnnnnnn.nnnnnnnn.nhhhhhhh 11111111.11111111.11111111.10000000	512	126
/26	255.255.255.192	nnnnnnnn.nnnnnnnn.nnnnnnnn.nnhhhhhh 11111111.11111111.11111111.11000000	1024	62
/27	255.255.255.224	nnnnnnnn.nnnnnnnn.nnnnnnnn.nnnhhhhh 11111111.11111111.11111111.11100000	2048	30

Creating 100 Subnets with a /16 Network

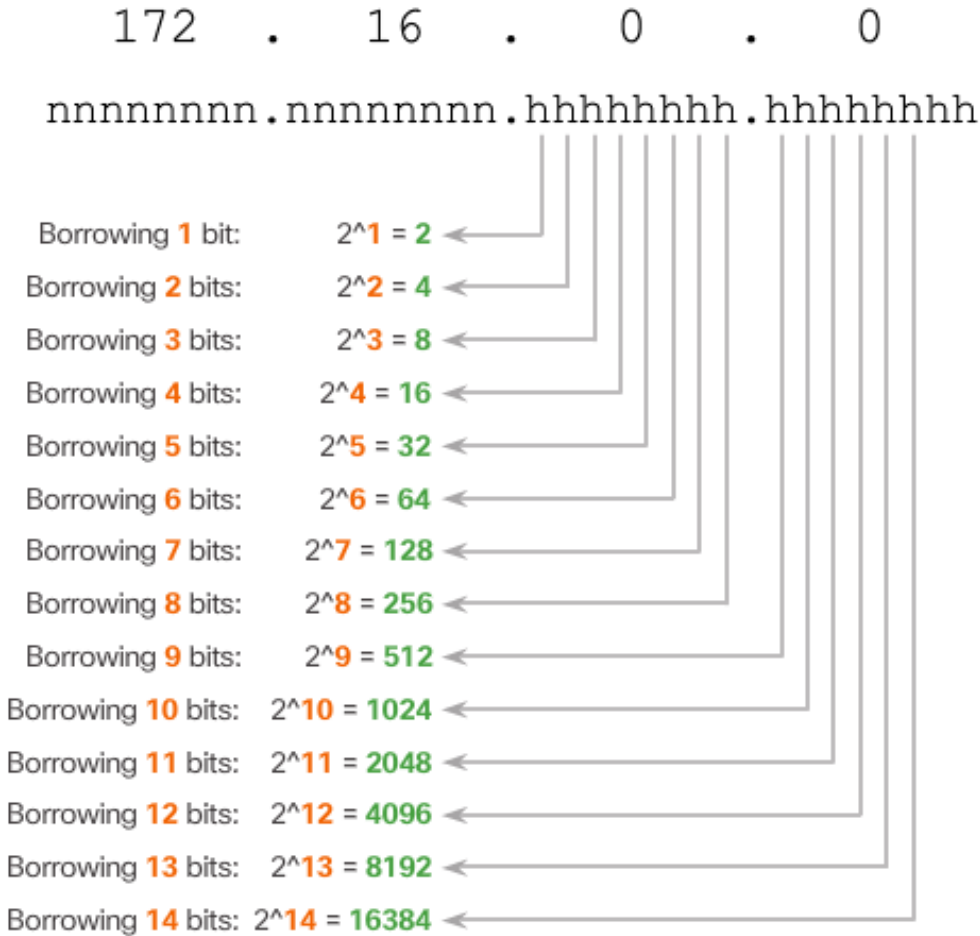

Creating 100 Subnets with a /16 Network (cont.)

Resulting /23 Subnets



Calculating the Hosts

Hosts = 2^n
(where n = host bits remaining)

172. 16. 00 00 00 00. 0000 0000

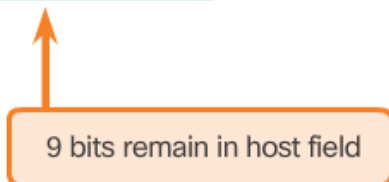

$2^9 = 512$ hosts per subnet
 $2^9 - 2 = 510$ valid hosts per subnet

Address Range for 172.16.0.0/23 Subnet

Network Address

172. 16. 00 00 00 00. 0000 0000 = 172.16.0.0/23

First Host Address

172. 16. 00 00 00 00. 0000 0001 = 172.16.0.1/23

Last Host Address

172. 16. 00 00 00 01. 1111 1110 = 172.16.1.254/23

Broadcast Address

172. 16. 00 00 00 01. 1111 1111 = 172.16.1.255/23

Creating 1000 Subnets with a /8 Network

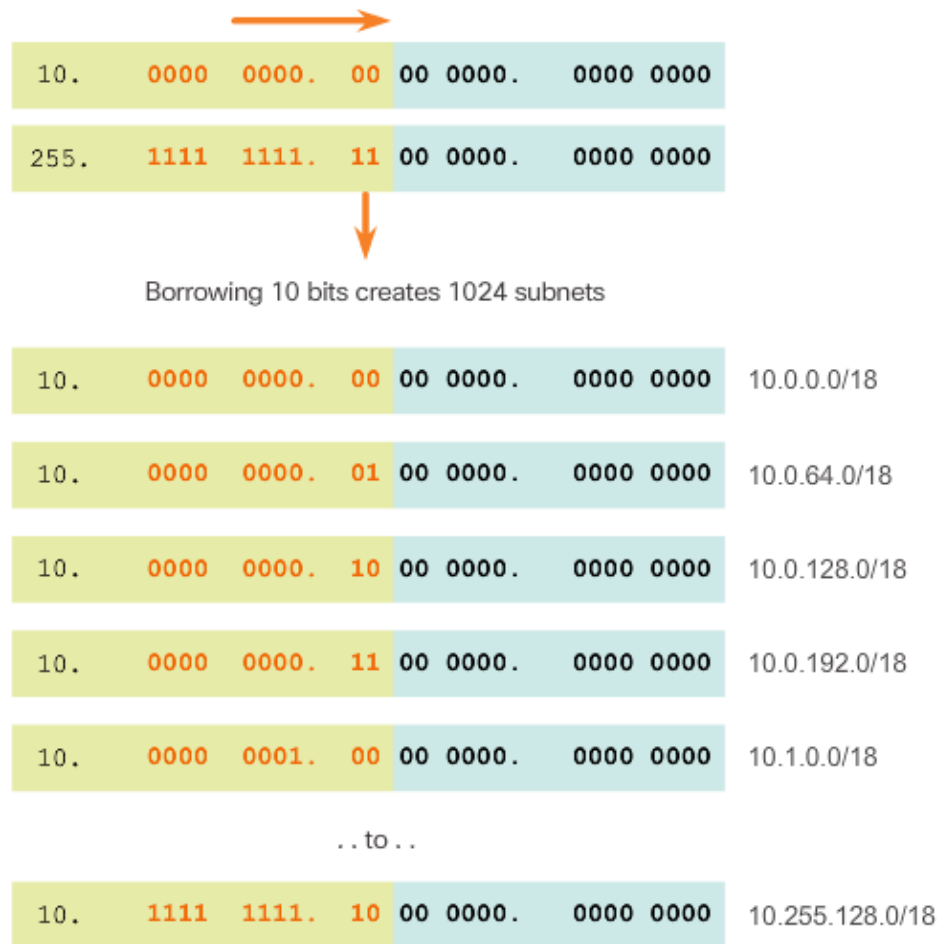

Creating 1000 Subnets with a /8 Network (cont.)

Calculating Hosts

10. 00 00 00 00. 0000 0000. 0000 0000

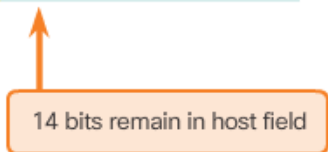

$2^{14} = 16384$ hosts per subnet
 $2^{14} - 2 = 16382$ valid hosts per subnet

Address Range for 10.0.0.0/18 Subnet

Network Address	10. 00 00 00 00. 0000 0000. 0000 0000	= 10.0.0.0/18
First Host Address	10. 00 00 00 00. 0000 0000. 0000 0001	= 10.0.0.1/18
Last Host Address	10. 00 00 00 00. 0011 1111. 1111 1110	= 10.0.63.254/18
Broadcast Address	10. 00 00 00 00. 0011 1111. 1111 1111	= 10.0.63.255/18

Topic 8.1.4: Subnetting to Meet Requirements



Subnetting Based on Host Requirements

Two considerations when planning subnets:

- The number of host addresses required for each network.
- The number of individual subnets needed.

Prefix Length	Subnet Mask	Subnet Mask in Binary (n = network, h = host)	# of subnets	# of hosts
/25	255.255.255.128	nnnnnnnn . nnnnnnnn . nnnnnnnn . nhhhhhhh 11111111 . 11111111 . 11111111 . 10000000	2	126
/26	255.255.255.192	nnnnnnnn . nnnnnnnn . nnnnnnnn . nnhhhhhh 11111111 . 11111111 . 11111111 . 11000000	4	62
/27	255.255.255.224	nnnnnnnn . nnnnnnnn . nnnnnnnn . nnnhhhhh 11111111 . 11111111 . 11111111 . 11100000	8	30
/28	255.255.255.240	nnnnnnnn . nnnnnnnn . nnnnnnnn . nnnnhhhh 11111111 . 11111111 . 11111111 . 11110000	16	14
/29	255.255.255.248	nnnnnnnn . nnnnnnnn . nnnnnnnn . nnnnnhhh 11111111 . 11111111 . 11111111 . 11111000	32	6
/30	255.255.255.252	nnnnnnnn . nnnnnnnn . nnnnnnnn . nnnnnnhh 11111111 . 11111111 . 11111111 . 11111100	64	2

The more bits borrowed to create subnets, the fewer host bits available.

Subnetting Based on Network Requirements

Subnets Based on Organizational Structure



Network Requirement Example

Corporate Network

Base Network Address: 172.16.0.0/22

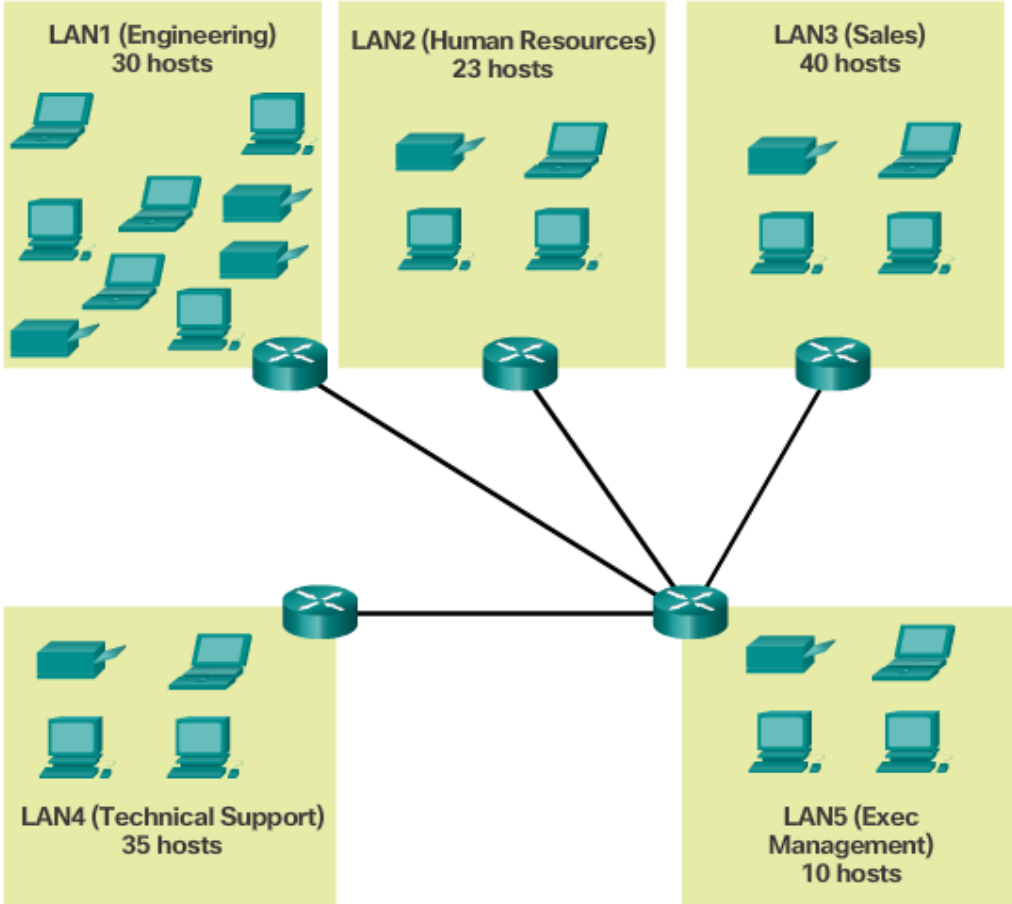

Select Subnet Parameters

1. Base Network Address: 172.16.0.0/22 which has 10 host bits

2. Select number of host bits per subnet:

Maximum number of hosts per subnet = 40

$$2^6 - 2 = 62 \text{ Hosts}$$

h=6: # host bits

$$2^5 - 2 = 30 \text{ Hosts}$$

h=5: # host bits

Therefore required number host bits = 6

3. Number of remaining bits for subnet = 4

Number of subnets with 4 bits = 16

Number of required subnets = 5

$$2^4 = 16 \text{ Subnets}$$

s=4: # subnet bits

New subnet mask is /26

Network Requirement Example (cont.)

	Network Portion	Host Portion	Dotted Decimal
	10101100.00010000.000000	00.00 000000	172.16.0.0/22
0	10101100.00010000.000000	00.00 000000	172.16.0.0/26
1	10101100.00010000.000000	00.01 000000	172.16.0.64/26
2	10101100.00010000.000000	00.10 000000	172.16.0.128/26
3	10101100.00010000.000000	00.11 000000	172.16.0.192/26
4	10101100.00010000.000000	01.00 000000	172.16.1.0/26
5	10101100.00010000.000000	01.01 000000	172.16.1.64/26
6	10101100.00010000.000000	01.10 000000	172.16.1.128/26
Nets 7 - 13 not shown			
14	10101100.00010000.000000	11.10 000000	172.16.3.128/26
15	10101100.00010000.000000	11.11 000000	172.16.3.192/26

4 bits borrowed from host portion to create subnets

Network Requirement Example (cont.)

172.16.0.0/22

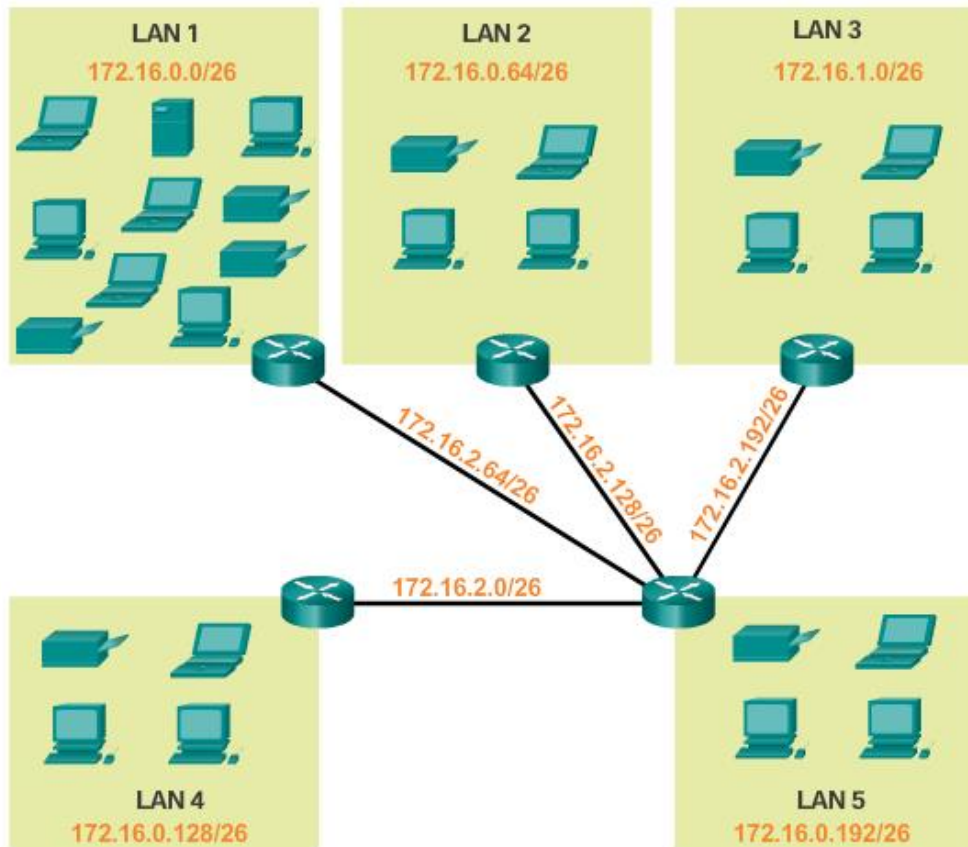

Topic 8.1.5: Benefits of Variable Length Subnetting Masking



Traditional Subnetting Wastes Addresses

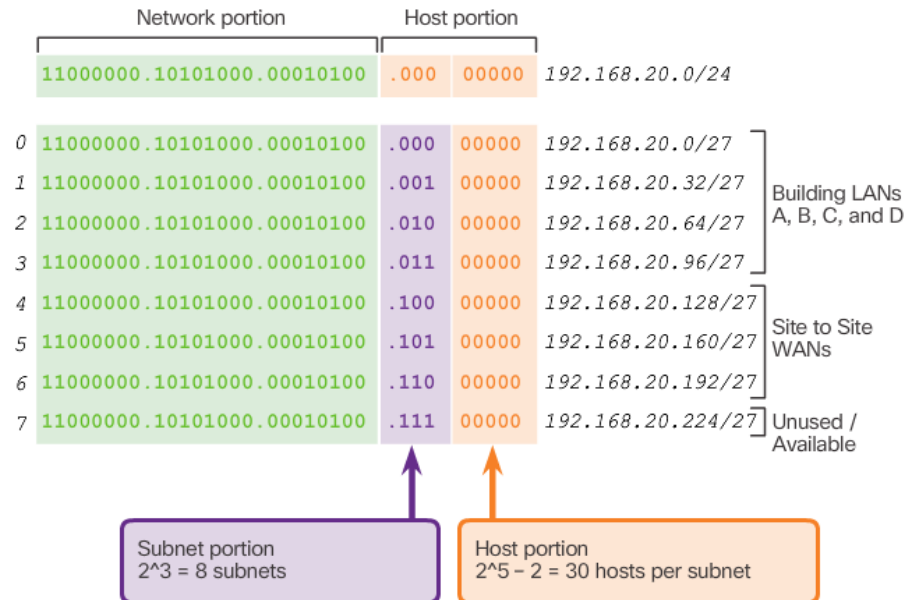
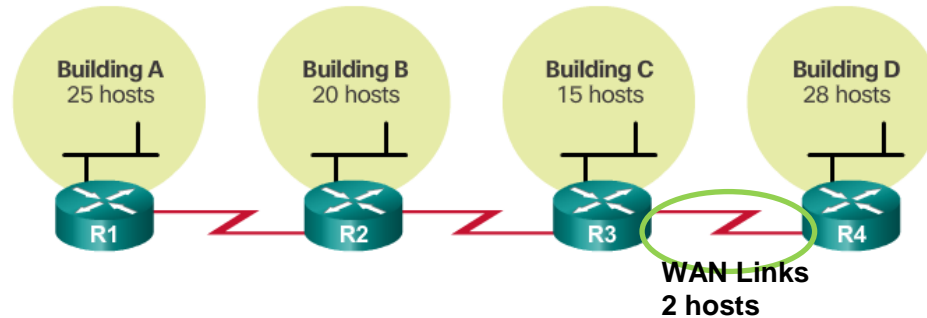

Traditional Subnetting Wastes Addresses (Cont.)

Unused Addresses on WAN Subnets



Host portion
 $2^5 - 2 = 30$ hosts per subnet

$30 - 2 = 28$
Each WAN subnet wastes 28 addresses

$28 \times 3 = 84$
84 addresses are unused

Variable Length Subnet Masks

Traditional Subnetting Creates Equal Sized Subnets

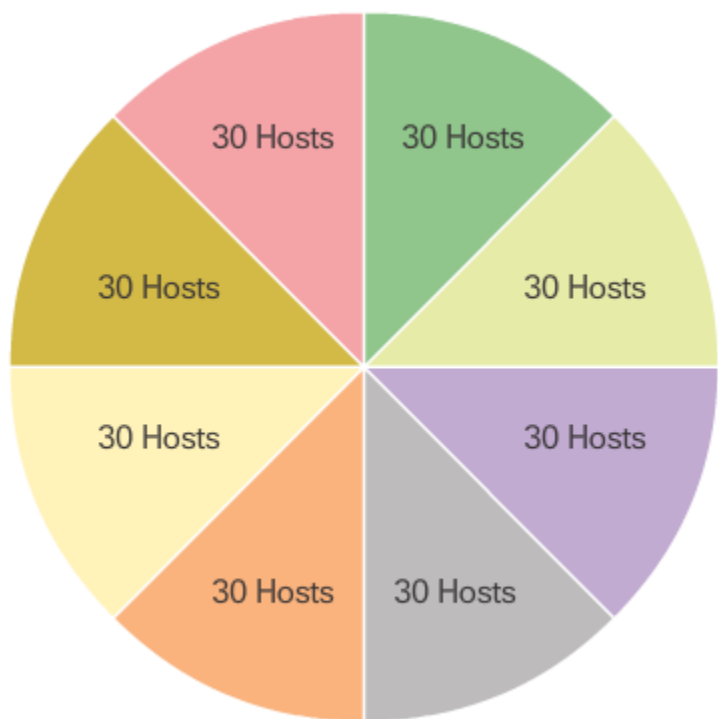

Subnets of Varying Sizes

One subnet was further divided to create 8 smaller subnets of 4 hosts each

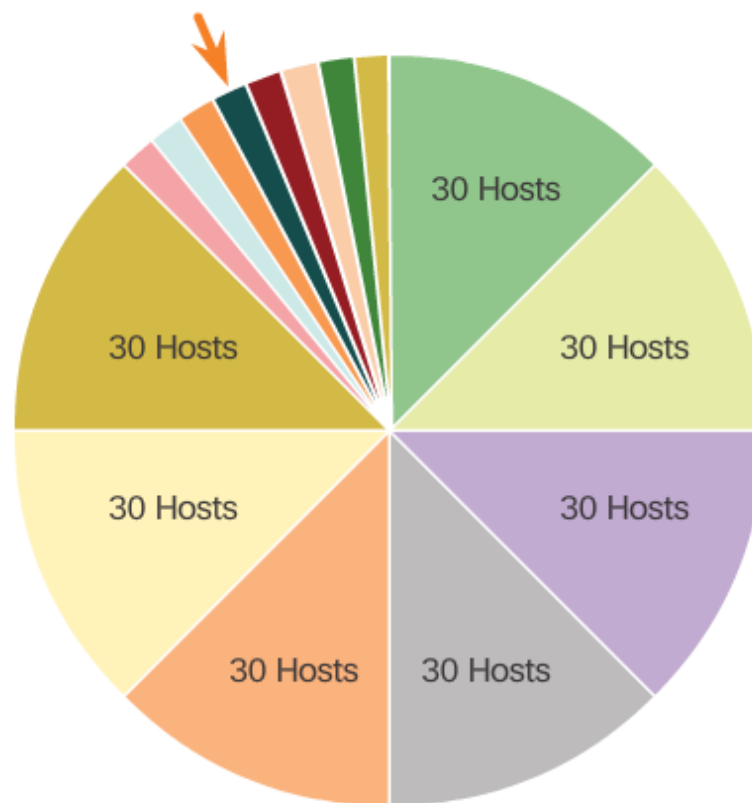

Section 8.2: Addressing Schemes

Upon completion of this section, you should be able to:

- Implement a VLSM addressing scheme.

Section 8.3:

Design Considerations for IPv6

Upon completion of this section, you should be able to:

- Explain how to implement IPv6 address assignments in a business network.

Topic 8.3.1: Subnetting an IPv6 Network



The IPv6 Global Unicast Address

The IPv6 global unicast address normally consists of a /48 global routing prefix, a 16 bit subnet ID, and a 64 bit interface ID.

IPv6 Global Unicast Address Structure

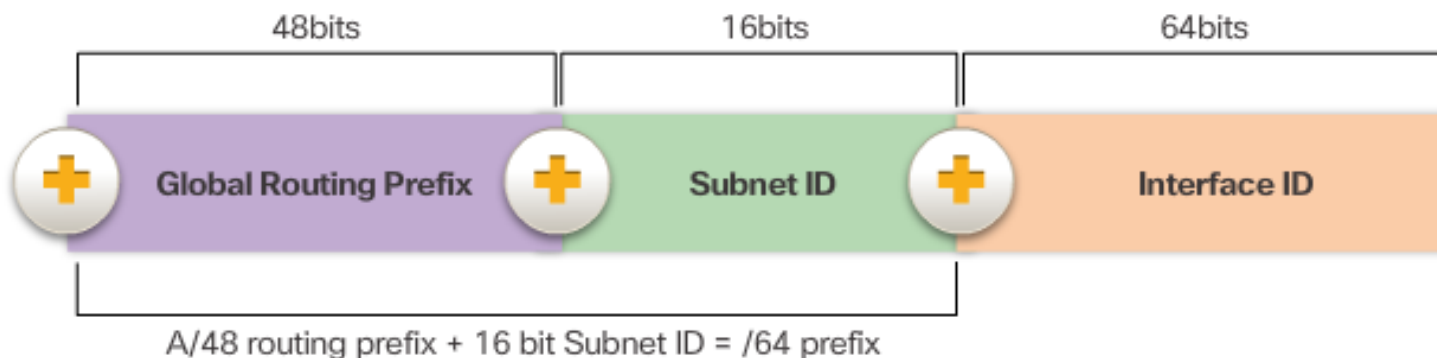

Subnetting Using the Subnet ID

Address Block: 2001:0DB8:ACAD::/48

Increment subnet
ID to create
65,536 subnets

2001:0DB8:ACAD:0000::/64
2001:0DB8:ACAD:0001::/64
2001:0DB8:ACAD:0002::/64
2001:0DB8:ACAD:0003::/64
2001:0DB8:ACAD:0004::/64
2001:0DB8:ACAD:0005::/64
2001:0DB8:ACAD:0006::/64
2001:0DB8:ACAD:0007::/64
2001:0DB8:ACAD:0008::/64
2001:0DB8:ACAD:0009::/64
2001:0DB8:ACAD:000A::/64
2001:0DB8:ACAD:000B::/64
2001:0DB8:ACAD:000C::/64

Subnets 13 - 65,534 not
shown

2001:0DB8:ACAD:FFFF::/64

IPv6 Subnet Allocation

Example Topology

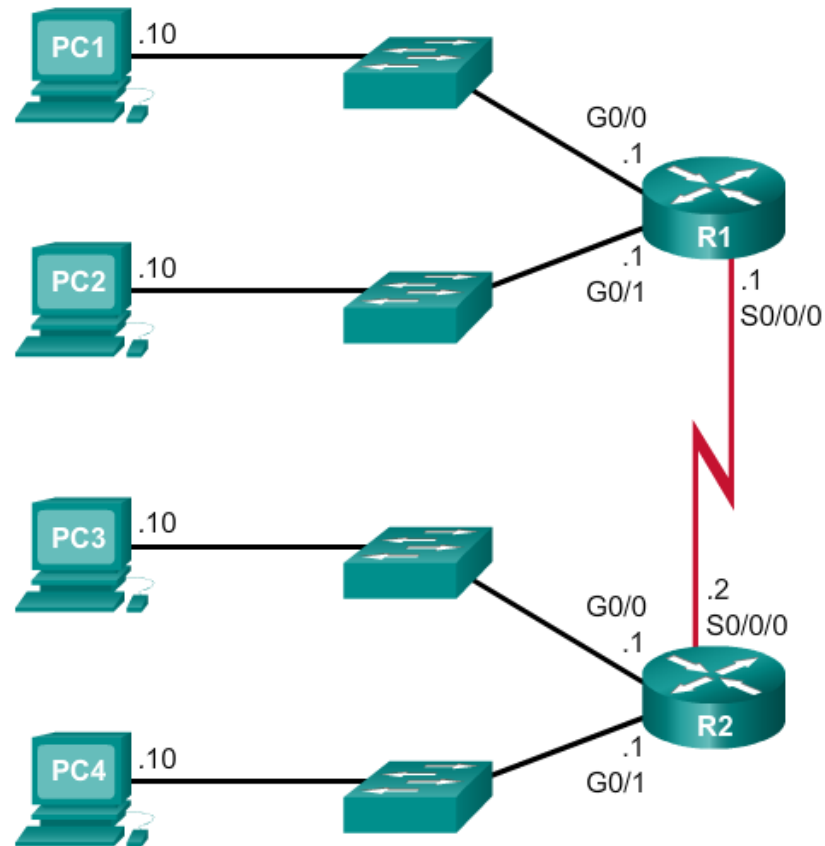

IPv6 Subnet Allocation (cont.)

Address Block: 2001:0DB8:ACAD::/48

5 subnets allocated
from 65,536
available subnets

```
2001:0DB8:ACAD:0000::/64
2001:0DB8:ACAD:0001::/64
2001:0DB8:ACAD:0002::/64
2001:0DB8:ACAD:0003::/64
2001:0DB8:ACAD:0004::/64
2001:0DB8:ACAD:0005::/64
2001:0DB8:ACAD:0006::/64
2001:0DB8:ACAD:0007::/64
2001:0DB8:ACAD:0008::/64
      ⋮
2001:0DB8:ACAD:FFFF::/64
```

IPv6 Subnet Allocation (cont.)

IPv6 Subnet Allocation

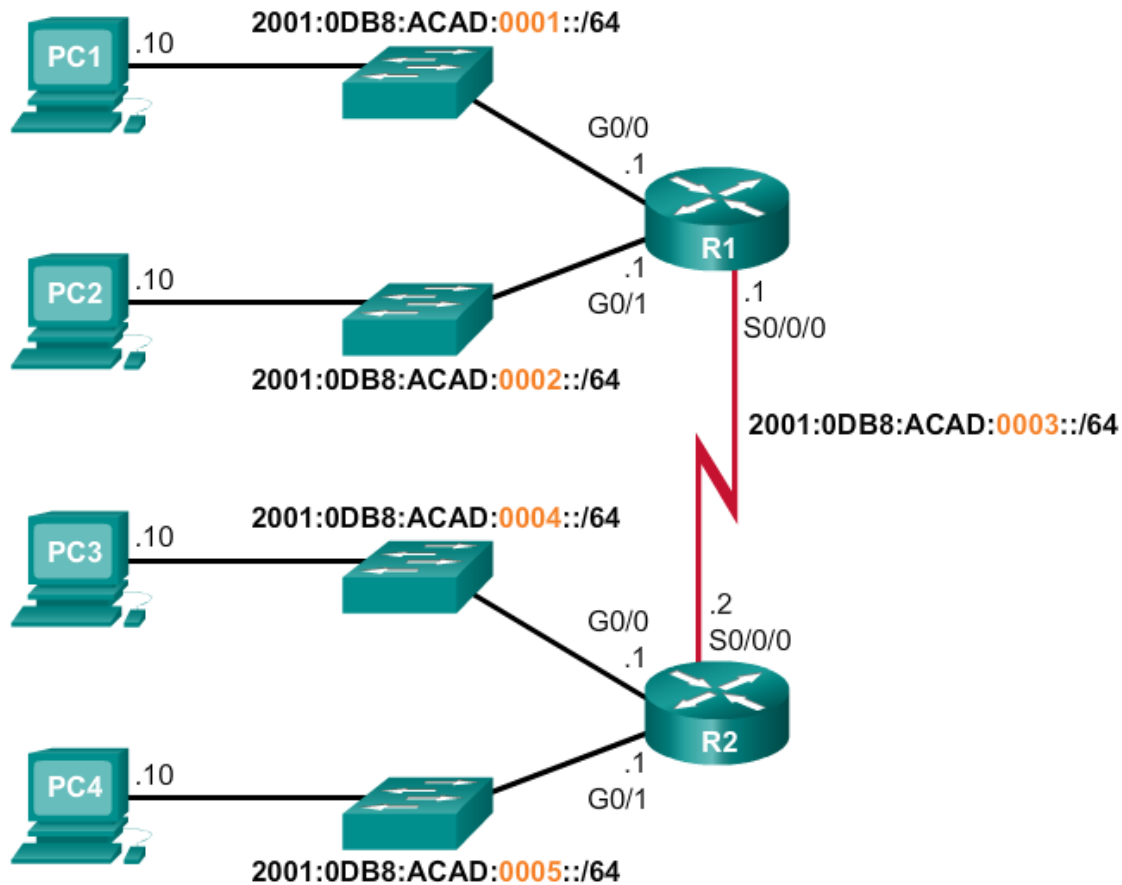

Section 8.4: Summary

Chapter Objectives:

- Implement an IPv4 addressing scheme to enable end-to-end connectivity in a small to medium-sized business network.
- Given a set of requirements, implement a VLSM addressing scheme to provide connectivity to end users in a small to medium-sized network.
- Explain design considerations for implementing IPv6 in a business network.

Thank you.



Cisco Networking Academy
Mind Wide Open