

Chapter 6: Network Layer

Introduction to Networks v5.1
Updated by Marvin Krym



Chapter Outline

6.0 Introduction

6.1 Network Layer Protocols

6.2 Routing

6.3 Routers

6.4 Configure a Cisco Router

6.5 Summary

Topic 6.1.2: Characteristics of the IP Protocol



Network Layer Protocols

Responsible for:

Routing:

- Determine the path to reach relevant destination networks
- Dynamic and Static methods

Forwarding (Layer 3)

- Move and incoming Frame to the next hop Router interface.



- Internet Protocol version 4 (IPv4)
- Internet Protocol version 6 (IPv6)

Encapsulating IP (cont.)

Network Layer PDU = IP Packet

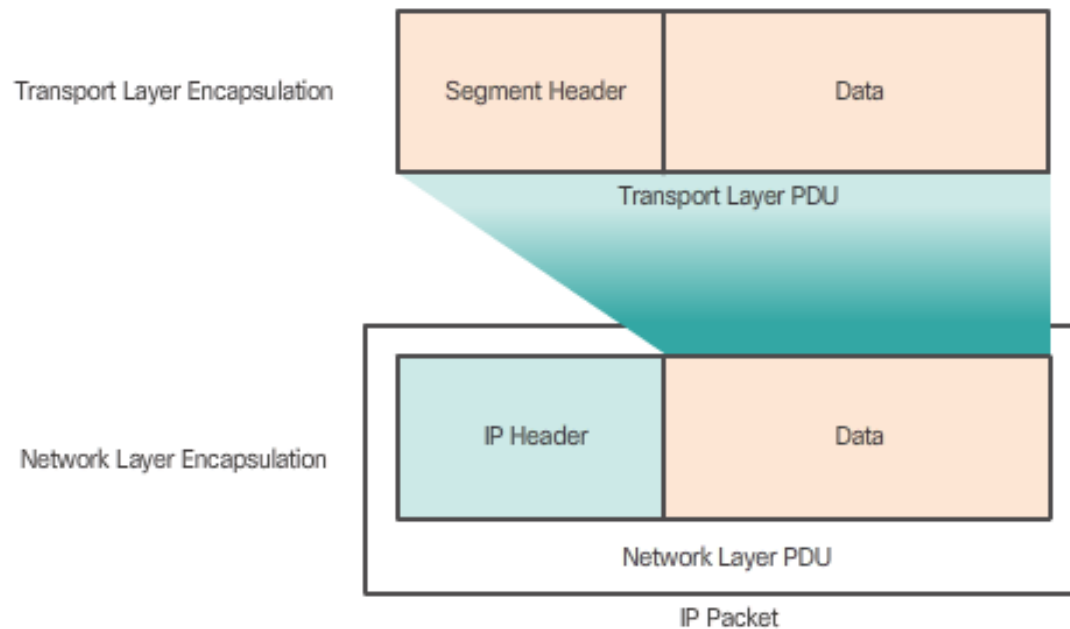

The network layer adds a header so packets can be routed through complex networks and reach their destination. In TCP/IP based networks, the network layer PDU is the IP Packet.

Characteristics of IP



Connectionless

No connection with the destination is established before sending data packets.

IP – Connectionless

Connection Management is done at the Transport Layer

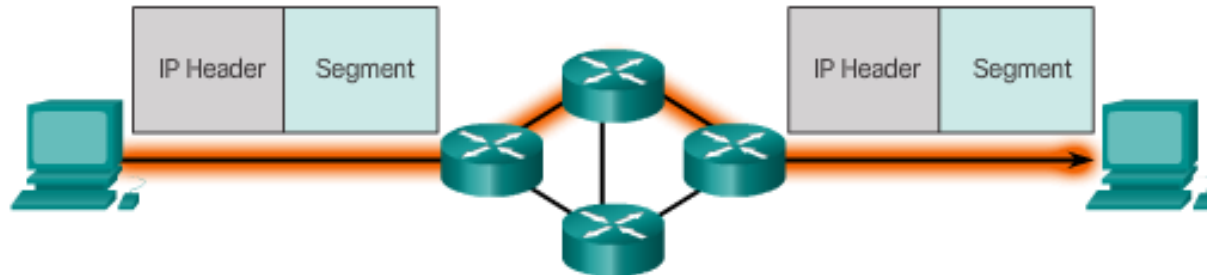

A packet is sent.

The sender doesn't know:

- If the receiver is present
- If the packet arrived
- If the receiver can read the packet

The receiver doesn't know:

- When it is coming
- **If the packets have arrived out of sequence**

IP – Media Independent

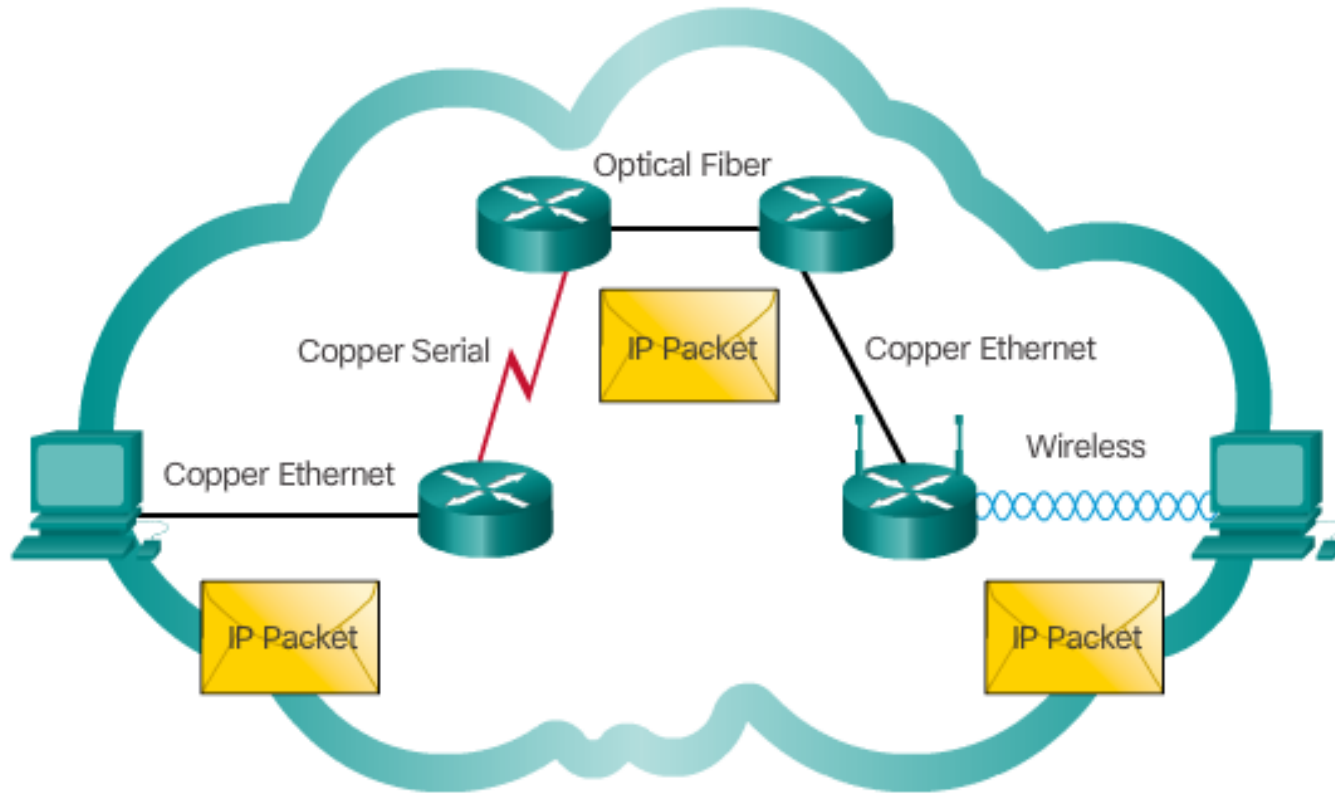

IP packets can travel over different media.

Topic 6.1.3: IPv4 Packet



IPv4 Packet Header

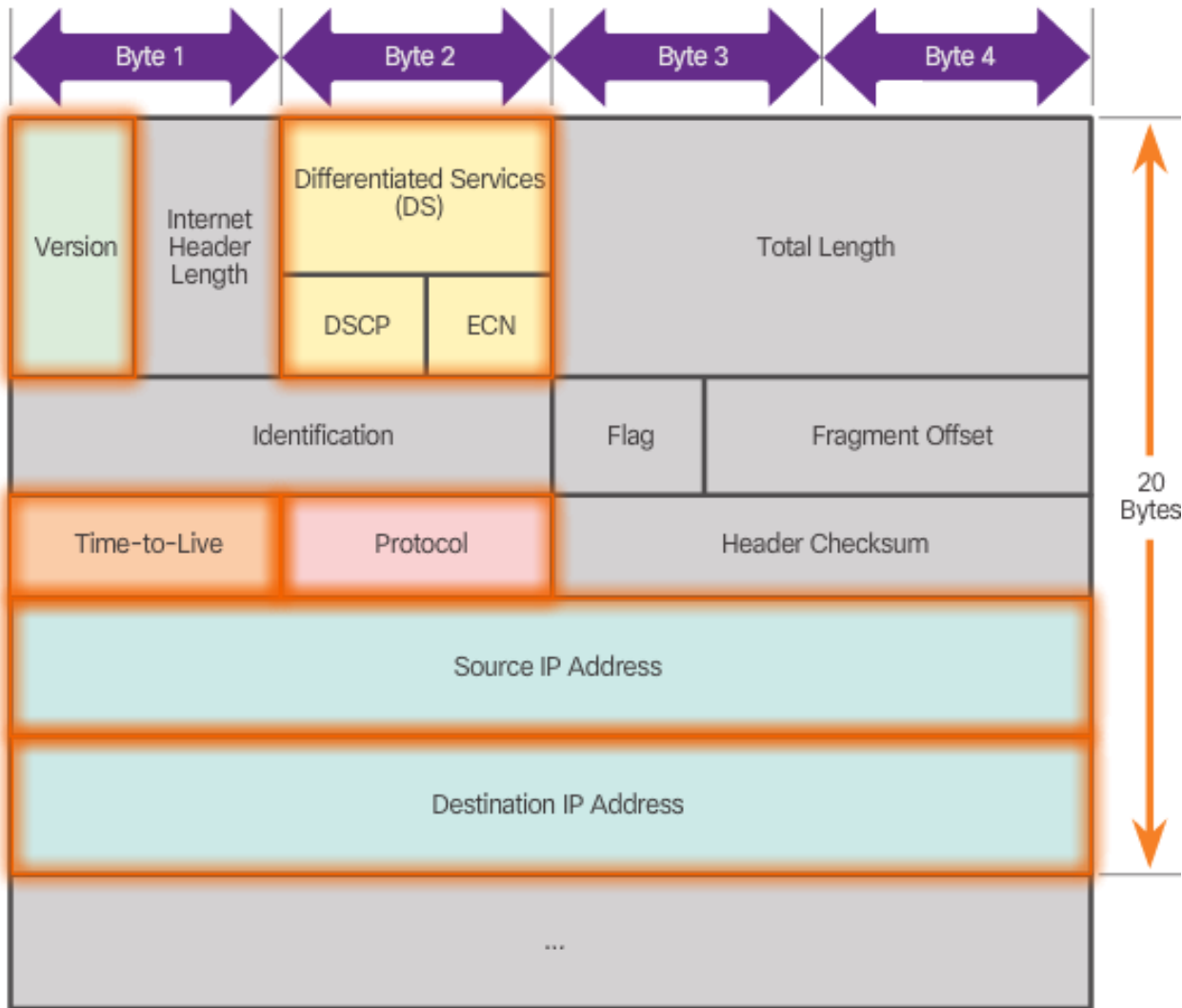

- Version = 0100 (binary)
- DS = Packet Priority
- TTL = Limits life of Packet
- Protocol = Upper layer protocol: TCP=6 or UDP=17
- Source IP Address = source of packet
- Destination IP Address = destination of packet

Time-to-Live TTL

- TTL value ranges from 0 – 255.
- Value is set by device (i.e. Microsoft 10 sets TTL = 64)
- Value is decrement until packet reaches destination or TTL timeout.
- Prevents packets from getting “stuck” in routing loop

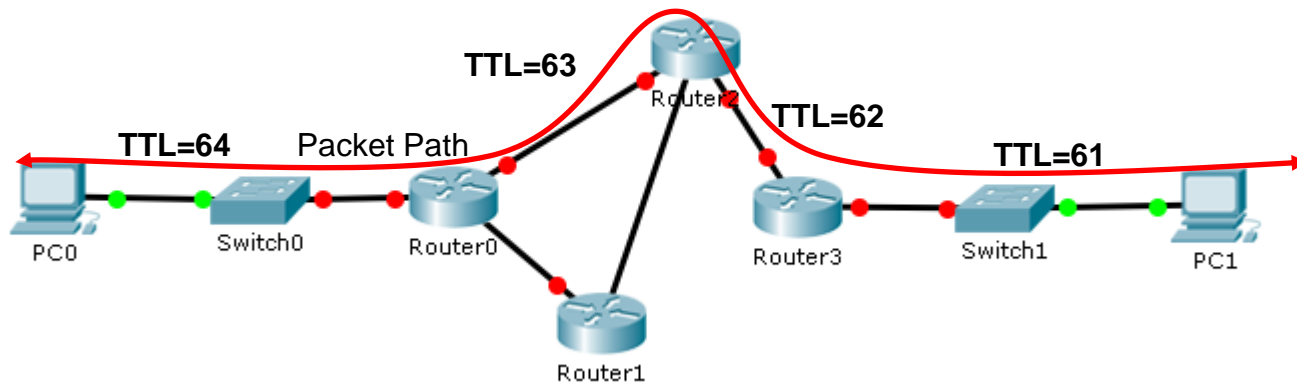

Topic 6.1.4: IPv6 Packet



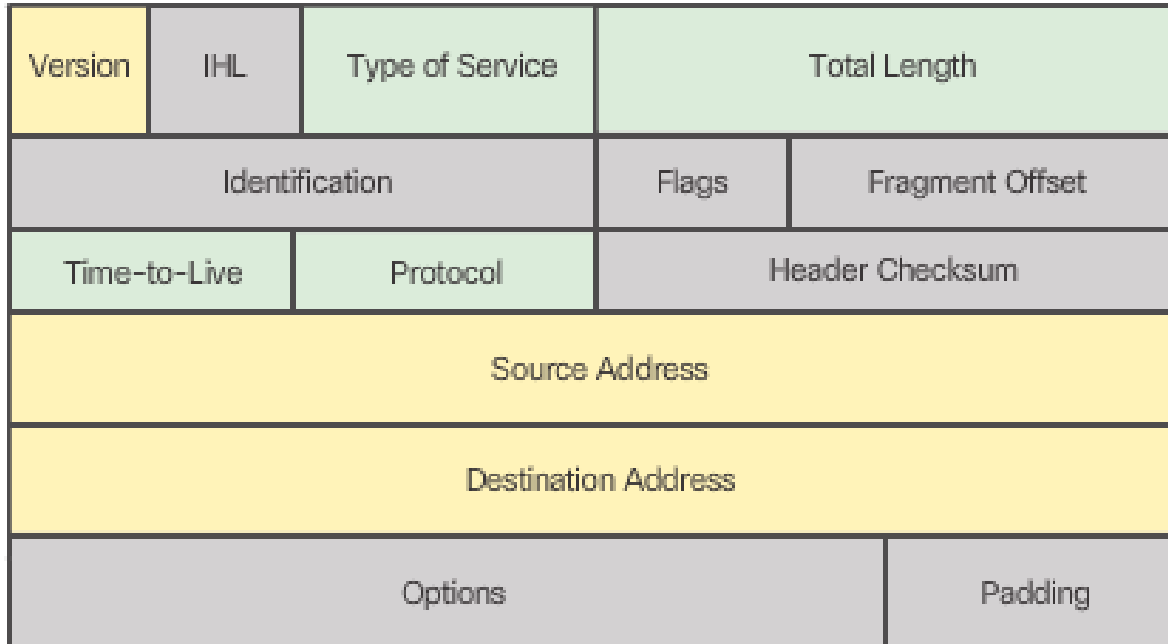

Encapsulating IPv6

IPv4 Header



IPv6 has a simplified header

-  - Field names kept from IPv4 to IPv6
-  - Name and position changed in IPv6
-  - Fields not kept in IPv6

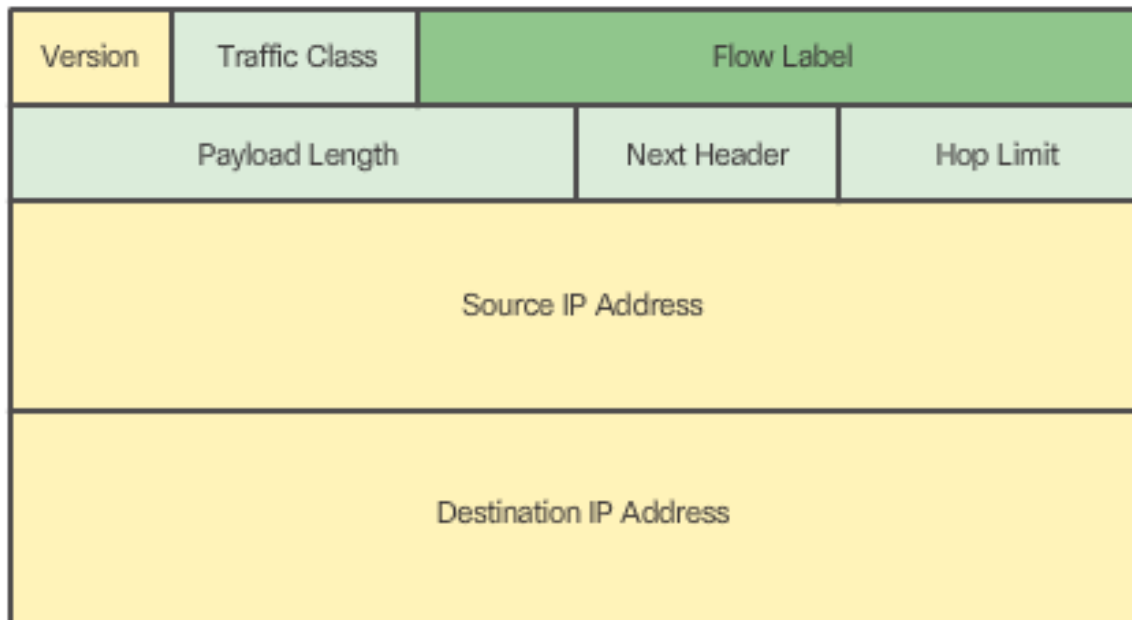

Encapsulating IPv6 (cont.)

IPv6 Header



IPv6 has a simplified header

Legend

-  - Field names kept from IPv4 to IPv6
-  - Name and position changed in IPv6
-  - New field in IPv6

IPv6 Packet Header

Fields in the IPv6 Packet Header

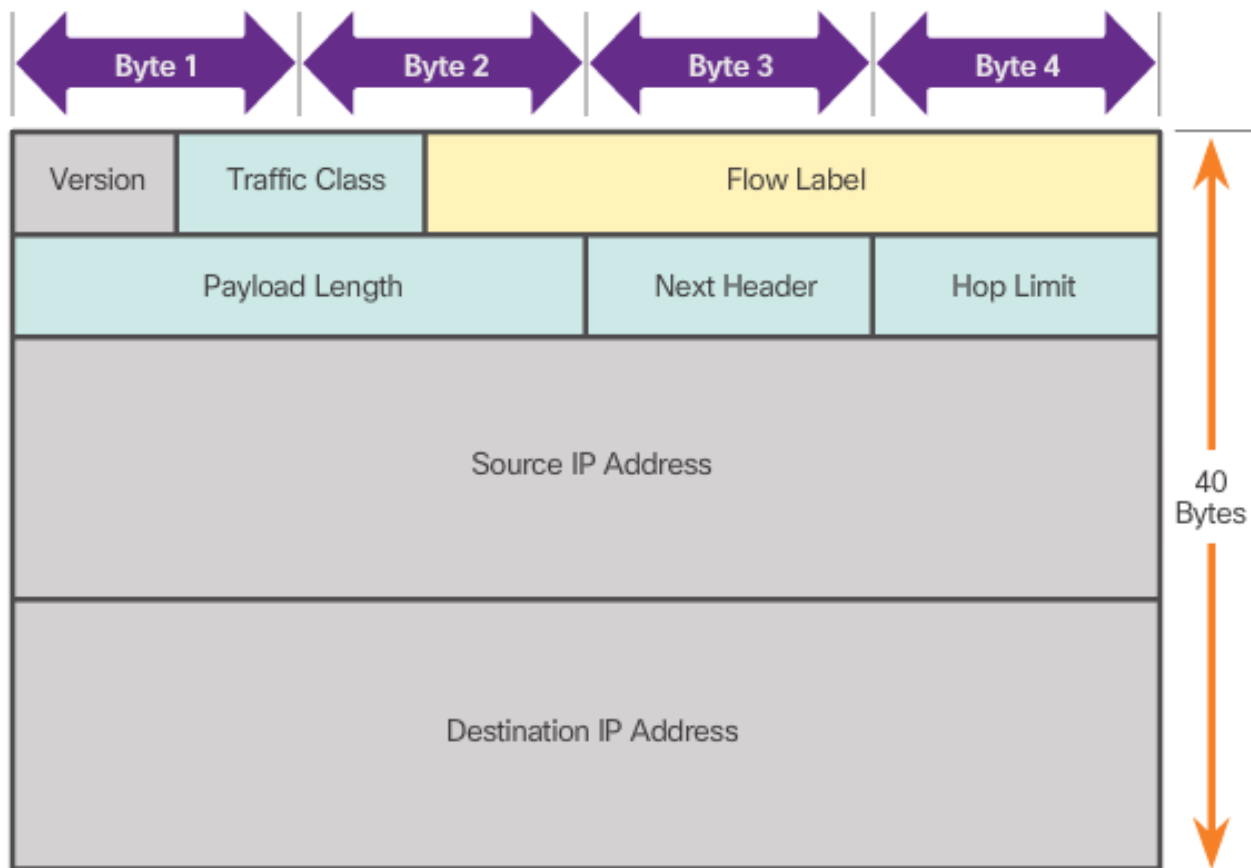

- Version = 0110 (binary)
- Traffic Class = Priority
- Flow Label = same flow will receive same handling
- Payload Length = same as total length
- Next Header = Layer 4 Protocol
- Hop Limit = Replaces TTL field

Section 6.2: Routing

Upon completion of this section, you should be able to:

- Explain how a host device uses routing tables to direct packets to itself, a local destination, or a default gateway.
- Compare a host routing table to a routing table in a router.

Topic 6.2.1: How a Host (i.e. End Device) Routes



Default Gateway

Default Gateway =
Router1 Interface IP Addr
(for Network Segment 1)

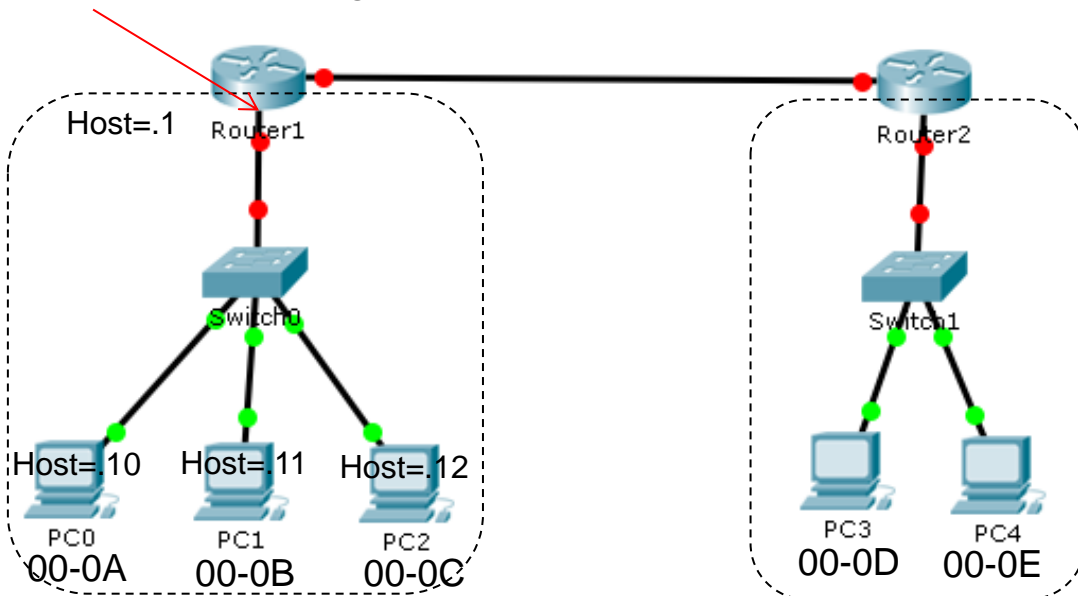

Network Segment 1

IP Network Address:
192.168.1.0
255.255.255.0

Network Segment 2

IP Network Address:
192.168.2.0
255.255.255.0

If Source IP Network Address EQUAL Destination IP Network Address then:

- Destination end device is on same network segment
- Switch frame to destination device

If Source IP Network Address NOT EQUAL Destination IP Network Address then:

- Destination end device is on a different network segment
- Switch frame to Default Router – Default Router will forward packet to Destination Network

Host Routing Tables

From a PC Command Prompt Enter:

route print

OR

netstat -r

Default Gateway

Indicated by Destination = 0.0.0.0

```
IPv4 Route Table
=====
Active Routes:
Network Destination        Netmask          Gateway          Interface        Metric
0.0.0.0                    0.0.0.0          192.168.1.1      192.168.1.125    25
127.0.0.0                  255.0.0.0        On-link          127.0.0.1        306
127.0.0.1                  255.255.255.255  On-link          127.0.0.1        306
127.255.255.255           255.255.255.255  On-link          127.0.0.1        306
192.168.1.0                255.255.255.0    On-link          192.168.1.125    281
192.168.1.125              255.255.255.255  On-link          192.168.1.125    281
192.168.1.255              255.255.255.255  On-link          192.168.1.125    281
224.0.0.0                  240.0.0.0        On-link          127.0.0.1        306
224.0.0.0                  240.0.0.0        On-link          192.168.1.125    281
255.255.255.255           255.255.255.255  On-link          127.0.0.1        306
255.255.255.255           255.255.255.255  On-link          192.168.1.125    281
=====
```

Topic 6.2.2: Router Routing Tables



IP Packet Forwarding

Routing Table

Dest Network	Next Hop
192.168.2.0/24	IP Addr of Rtr2

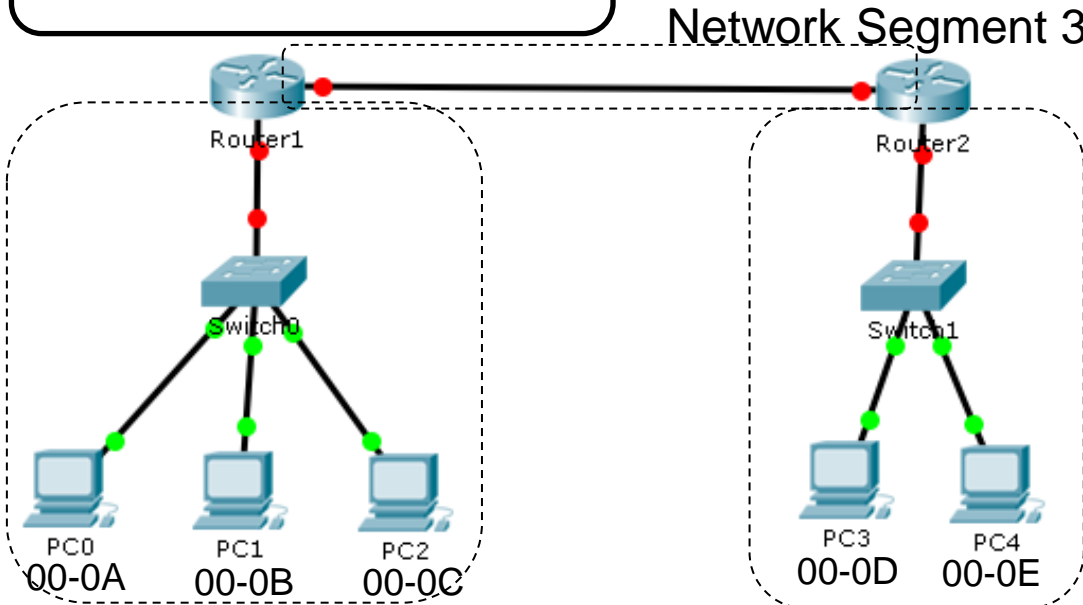

Network Segment 1

IP Network Address:
192.168.1.0
255.255.255.0

Network Segment 2

IP Network Address:
192.168.2.0
255.255.255.0

- Ethernet Switches forward frames between end devices that are on the same network segment using MAC addresses.
- Routers forward packets to remote networks and network segments using IP Addresses.
- Router interfaces define a network segment.
- Each end device will have an IP Address whose Network Address is the same as the Network segment.
- End devices with the same network address are on the same network segment.

Router Ports



Lab Router

4 LAN Ports 1 WAN Ports

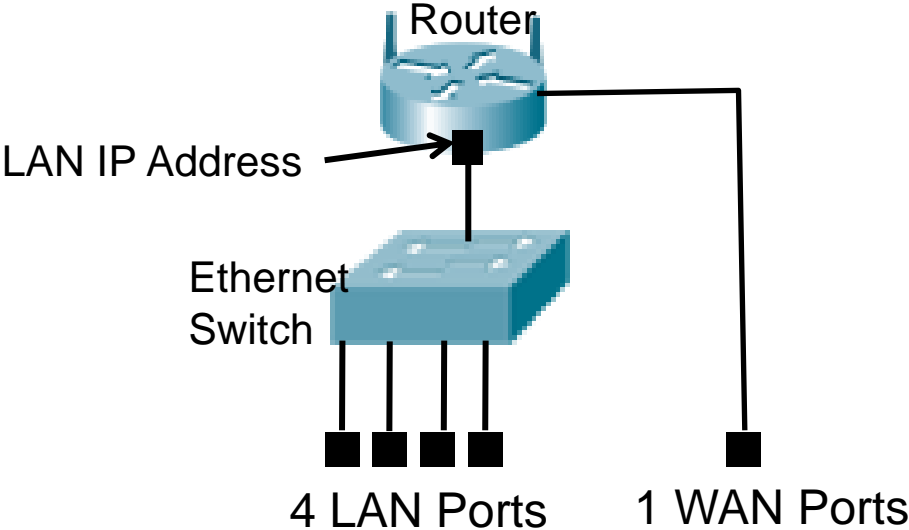

Equivalent Schematic

IPv4 Router Routing Table - 1

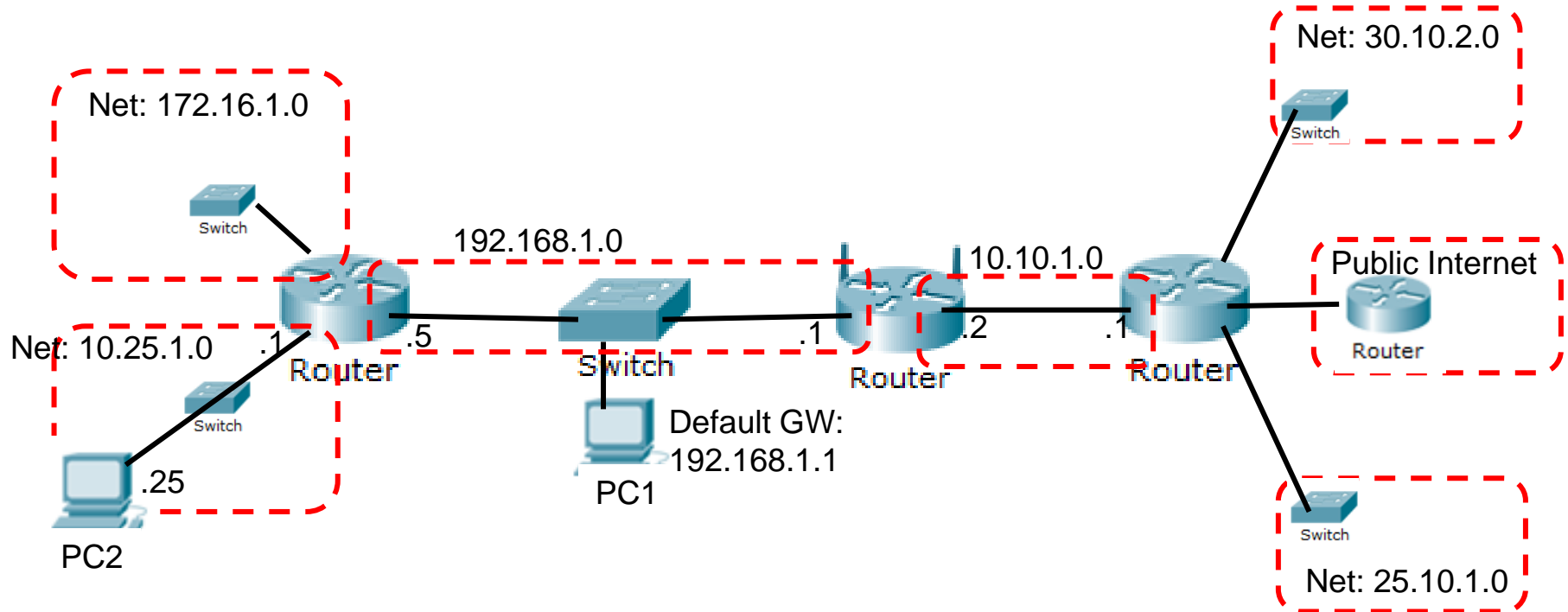

Consider the above network which includes several network segments.

IPv4 Router Routing Table - 2

Connected Networks

Destination LAN IP	Subnet Mask	Gateway	Hop Count	Interface
25.10.1.0	255.255.255.0	10.10.1.1	1	Internet (WAN)
192.168.1.0	255.255.255.0	0.0.0.0	1	LAN & Wireless
10.10.1.0	255.255.255.0	0.0.0.0	1	Internet (WAN)
172.16.1.0	255.255.255.0	192.168.1.5	1	LAN & Wireless
10.25.1.0	255.255.255.0	192.168.1.5	1	LAN & Wireless
30.10.2.0	255.255.255.0	10.10.1.1	1	Internet (WAN)
224.0.0.0	240.0.0.0	0.0.0.0	1	LAN & Wireless
0.0.0.0	0.0.0.0	10.10.1.1	1	Internet (WAN)

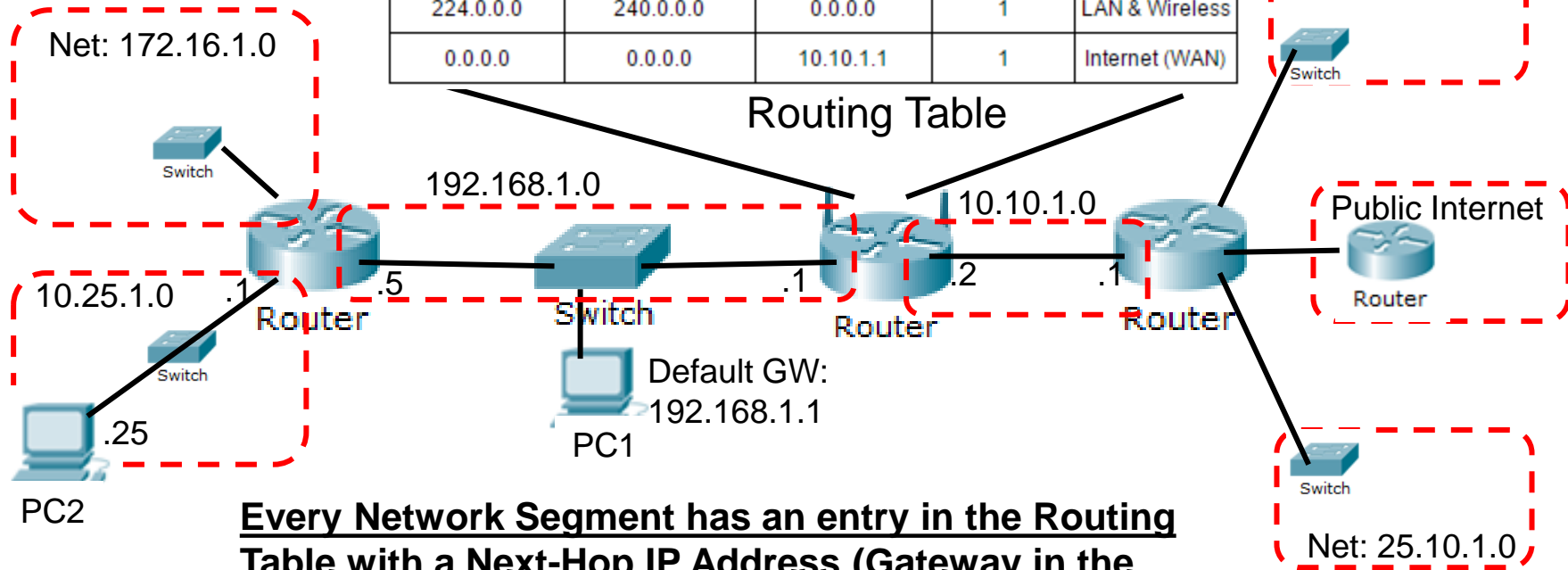

Every Network Segment has an entry in the Routing Table with a Next-Hop IP Address (Gateway in the Table)

Forwarding to a Remote Network

Connected Networks

Destination LAN IP	Subnet Mask	Gateway	Hop Count	Interface
25.10.1.0	255.255.255.0	10.10.1.1	1	Internet (WAN)
192.168.1.0	255.255.255.0	0.0.0.0	1	LAN & Wireless
10.10.1.0	255.255.255.0	0.0.0.0	1	Internet (WAN)
172.16.1.0	255.255.255.0	192.168.1.5	1	LAN & Wireless
10.25.1.0	255.255.255.0	192.168.1.5	1	LAN & Wireless
30.10.2.0	255.255.255.0	10.10.1.1	1	Internet (WAN)
224.0.0.0	240.0.0.0	0.0.0.0	1	LAN & Wireless
0.0.0.0	0.0.0.0	10.10.1.1	1	Internet (WAN)

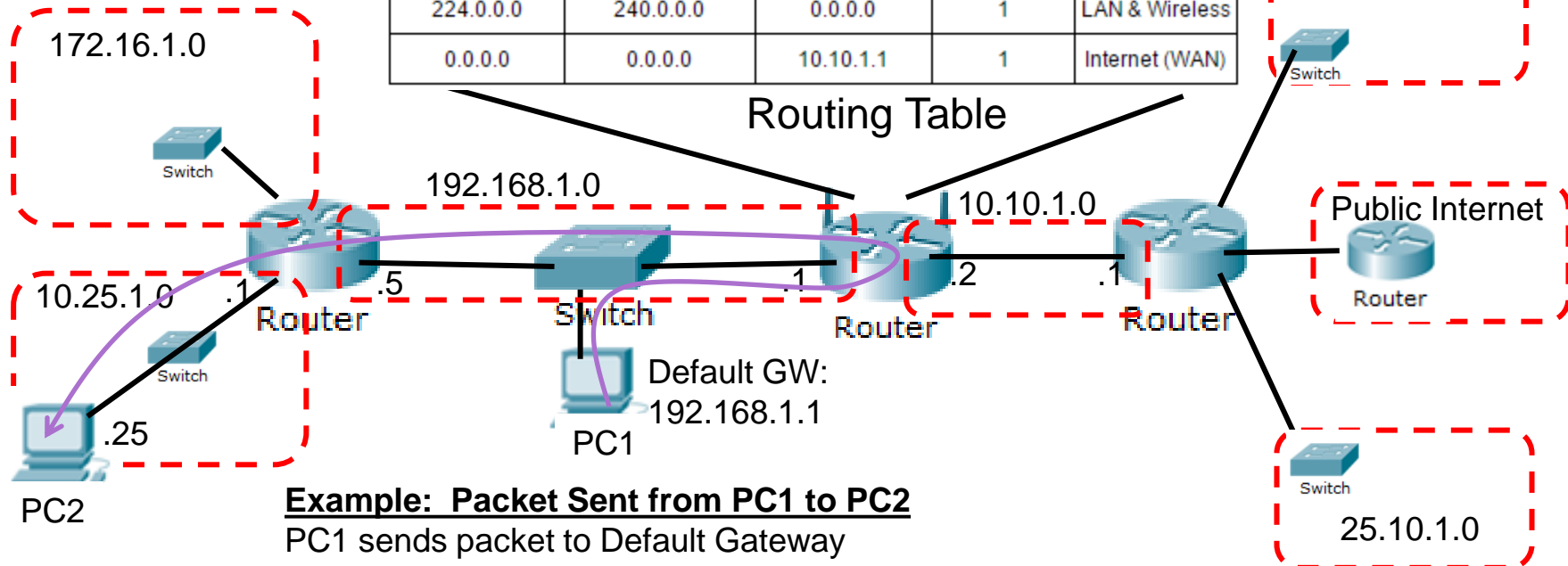

Example: Packet Sent from PC1 to PC2

PC1 sends packet to Default Gateway

Router forwards packet to 192.168.1.5 based on Routing Table lookup

Router forwards packet to egress interface

Router does ARP to get PC2 MAC Address

Router egress interfaces forwards frame to PC2

The Default Route

Connected Networks

Destination LAN IP	Subnet Mask	Gateway	Hop Count	Interface
25.10.1.0	255.255.255.0	10.10.1.1	1	Internet (WAN)
192.168.1.0	255.255.255.0	0.0.0.0	1	LAN & Wireless
10.10.1.0	255.255.255.0	0.0.0.0	1	Internet (WAN)
172.16.1.0	255.255.255.0	192.168.1.5	1	LAN & Wireless
10.25.1.0	255.255.255.0	192.168.1.5	1	LAN & Wireless
30.10.2.0	255.255.255.0	10.10.1.1	1	Internet (WAN)
224.0.0.0	240.0.0.0	0.0.0.0	1	LAN & Wireless
0.0.0.0	0.0.0.0	10.10.1.1	1	Internet (WAN)

Default Route

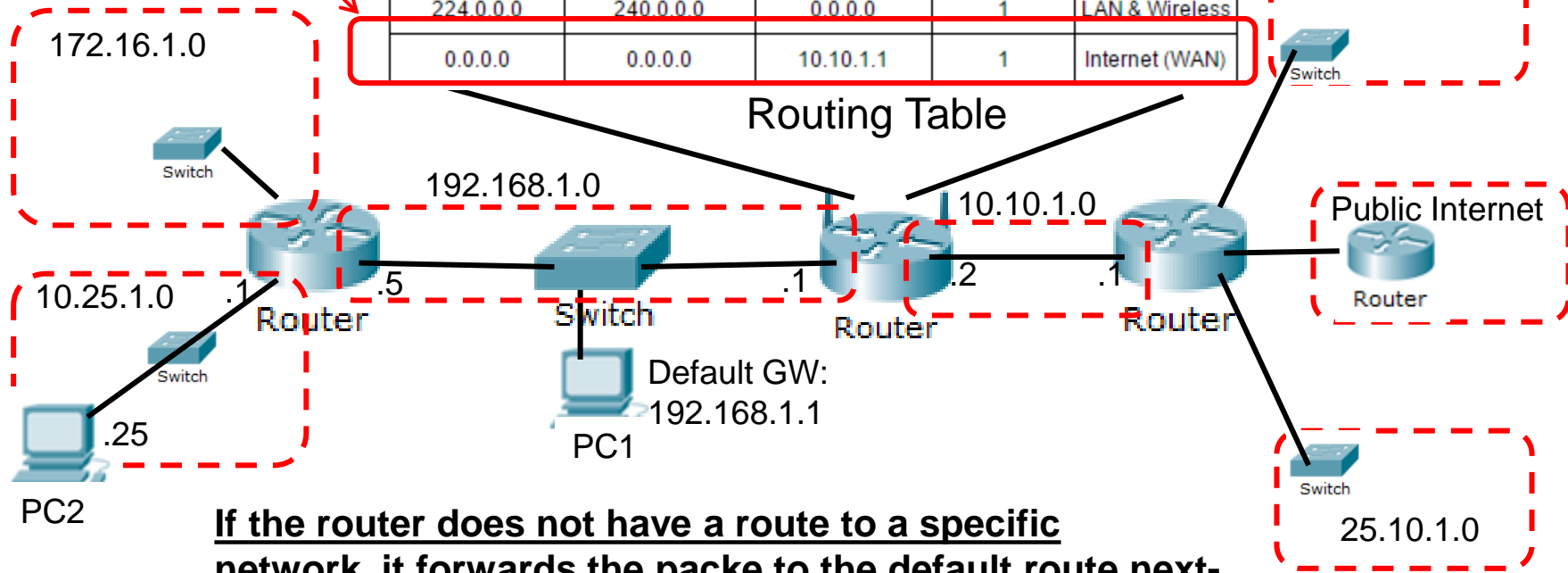

If the router does not have a route to a specific network, it forwards the packe to the default route next-hop address.

Thank you.



Cisco Networking Academy
Mind Wide Open