



## ELEC5508 / ELG6358

## Computer Methods for Analysis and Design of VLSI Circuits

Fall-2016

## Assignment-1

Date: Thurs., Oct. 6<sup>th</sup>, 2016

- For each question, attach Matlab code and (H-)spice netlist that you used.
- For Questions marked with the symbols:
  - the results (such as graphs,...) should be included in your report!
  - a (typed) written answer is needed.

**For the following questions 1 and 2:**

(a) Written answer is required.

(b) Include the circuit in your answer and clearly show how you numbered the nodes on your circuit diagrams.(c) Clearly show the size and all the entries of the **G**, **C**, **X**, and **b** in your answers.- The complex numbers should be shown in "a+jb" format.- The entries of **X** and **b** (signals):In frequency-domain should be shown as a functions of  $s$ , where  $s = j\omega$ ,e.g. show  $I_1(s)$  and NOT simply  $I_T$ .In time-domain should be shown as explicit functions of time  $t$ ,e.g. show  $i_1(t)$  and NOT  $i_T$ .**Question 1:**

Write the MNA matrix equations in the both frequency-domain and time-domain for the circuit shown in below. (Type!)

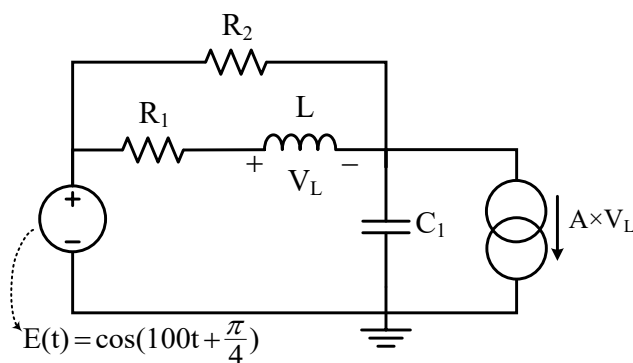

Q1\_Circuit-1

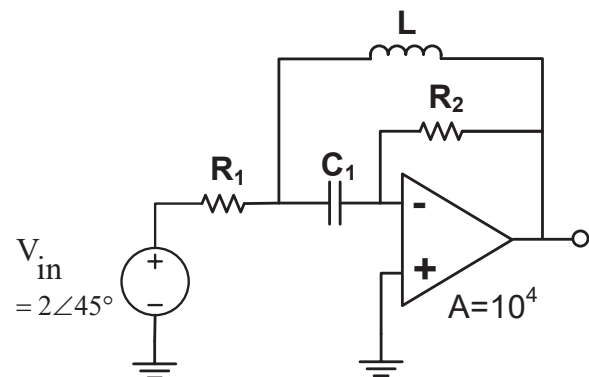

Q1\_Circuit-2

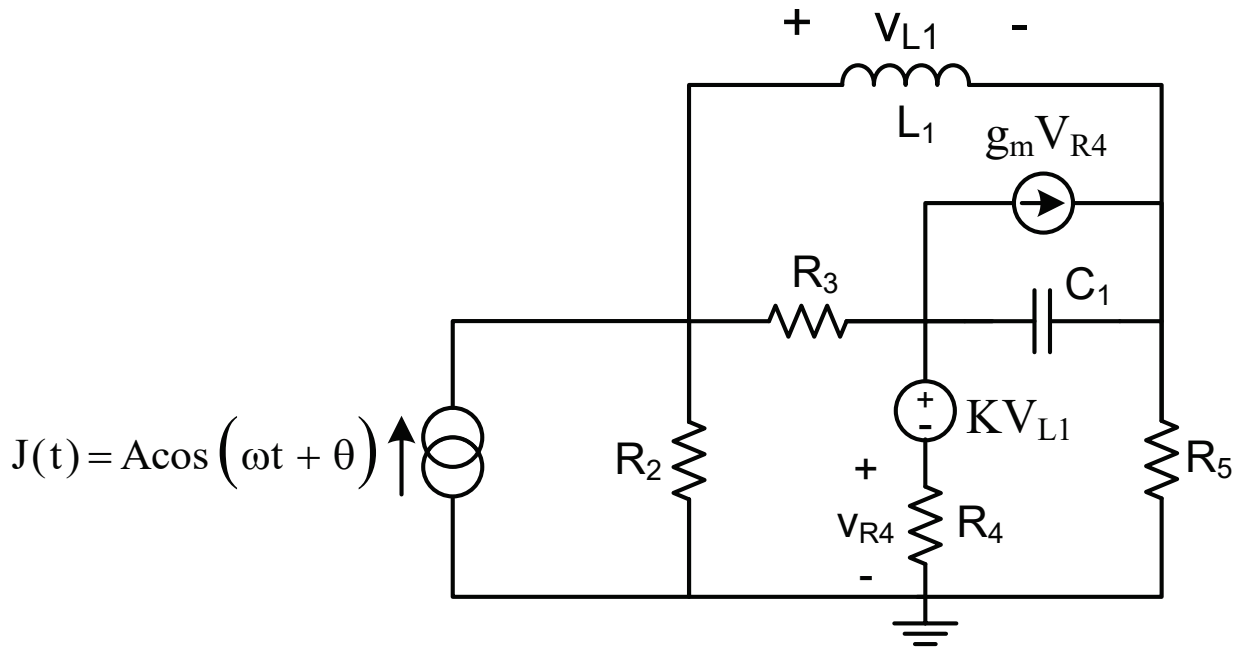

Q1\_Circuit-3

**Question 2:**

In the circuit shown in below, the op-amp Q1 is ideal ( $A = \infty$ ) and the gain of the op-amp Q2 as a function of frequency is given by:  $A = \frac{\alpha}{s + \beta}$ , where  $\alpha$  and  $\beta$  are constants.

Write the time-domain MNA matrix equations for the circuit.  (Type!)

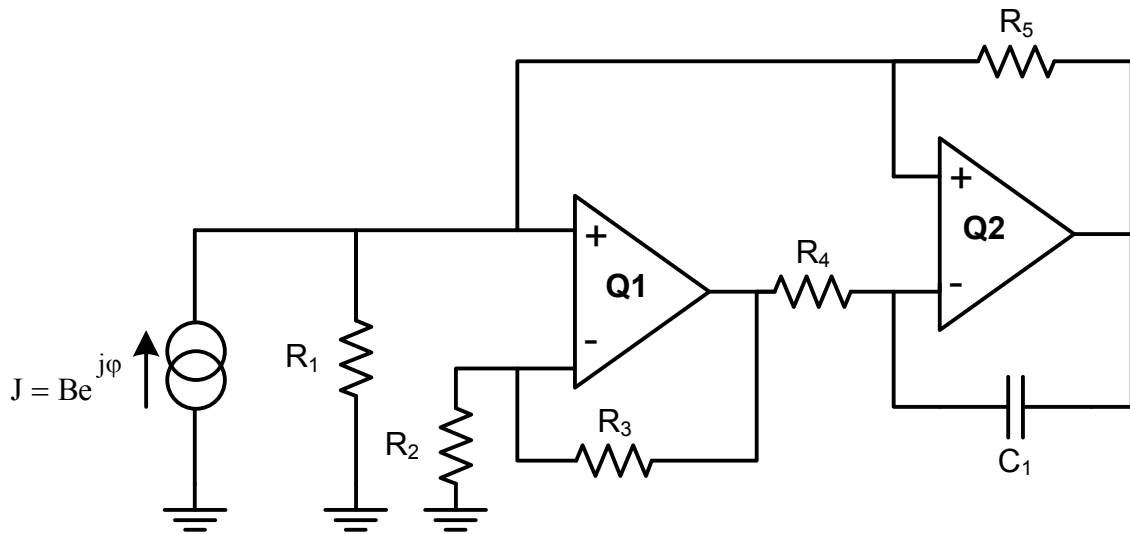

Q2\_Op-Amp Circuit

**Question 3:**

For the RLC circuit shown in below, derive the frequency-domain equations in the form  $(\mathbf{G} + s\mathbf{C}) \mathbf{X} = \mathbf{b}$  and check your results with the matrices given in the Matlab code for this question.

- (1) Solve the equations for the unknown vector  $\mathbf{X}$  for 1000 frequency points between  $f = 0Hz$  to  $f = 3MHz$ . Plot the magnitude of the output voltage  $|V_{out}|$  against frequency and include the resulting graph in your report. 

**Note:** Use the given Matlab code.

- (2) Simulate the circuit using HSPICE (or equivalent) and include the response graph from Hspice in your report. 

**Note:** Use the Hspice netlist provided.

- (3) Compare the results from the Matlab and Hspice by plotting both in the same graph. 

**Hint:** First, you need to save the Hspice-response data in a separate text file. To find this data, check the end of the “\*.lis” file which was automatically created in Hspice simulation. Then, use the Matlab program provided for this part.

- (4) Plot the steady-state response at the output ( $V_{out}$ ) and at the input ( $V_{in}$ ) vs. time at  $f = 1MHz$  over three periods and show them in one graph. 

**Note:** Complete and run the Matlab program provided for this part.

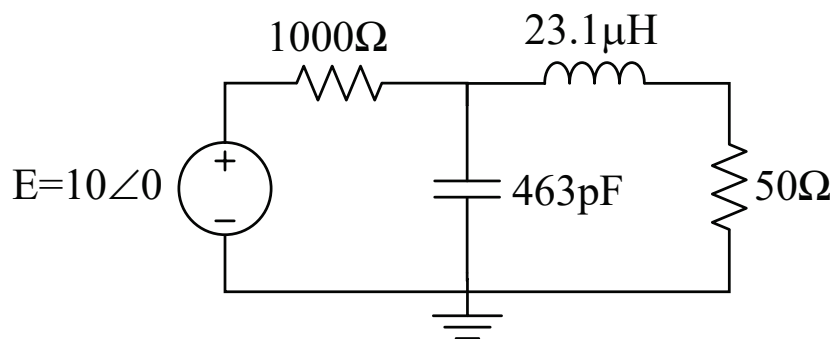

Q3\_RLC Circuit