

CONCORDIA UNIVERSITY
FACULTY OF ENGINEERING AND COMPUTER SCIENCE
Department of Mechanical and Industrial Engineering

MIDTERM 1
MECH 313: Machine Drawing and Design: Winter 2016
Maximum Marks = 50

Instructors: Drs. F. Tardy, H. Gomaa and S. Joshi

Date: 14 February 2016

Time: 90 minutes

NAME: _____
(Please Print) SURNAME FIRST NAME

STUDENT ID: _____ SECTION: _____

SIGNATURE: _____

INSTRUCTOR: _____

Name and student I/D must be written in INK.

All work must be illustrated in order to gain full marks assigned to the question.

INDIVIDUAL WORK - Closed Book Test

Material allowed: Approved calculator, Drawing equipment.

Answer the questions in the space provided.

Return the paper and data booklet at the end of the schedule time.

Q1 (10)	Q2 (10)	Q3 (15)	Q4 (15)	Total (50)

Q1. Circle the correct answer for the following multiple choice questions (only one). **(1X10)**

- The overall envelope of perfect form within which a feature would just fit is called
 - tolerance zone
 - virtual condition
 - profile
 - feature control frame
- The geometric dimensioning and tolerancing symbol used to control the location of the center of a circular hole is
 - \oplus
 - \sphericalangle
 - \frown
 - \textcircled{P}
- Form control is provided by
 - concentricity
 - cylindricity
 - position
 - symmetry
- The sectional view A-A in the adjacent figure is an example of a/an

- broken-out section
- revolved section
- offset section
- partial section

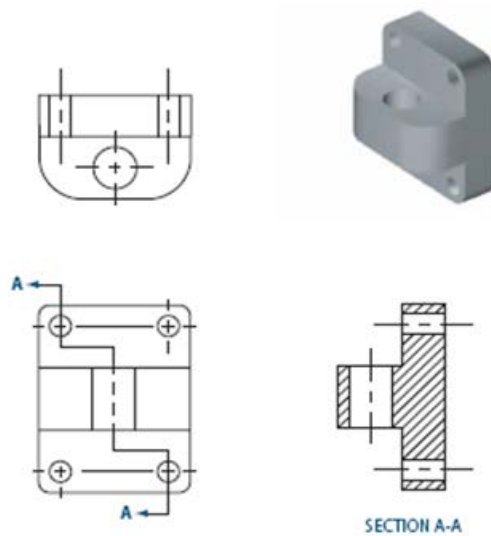

5. In the adjacent metric drawing, the dimensioning method shown is an example of

- A. chain dimensioning
- B. datum dimensioning
- C. direct dimensioning
- D. limit dimensioning

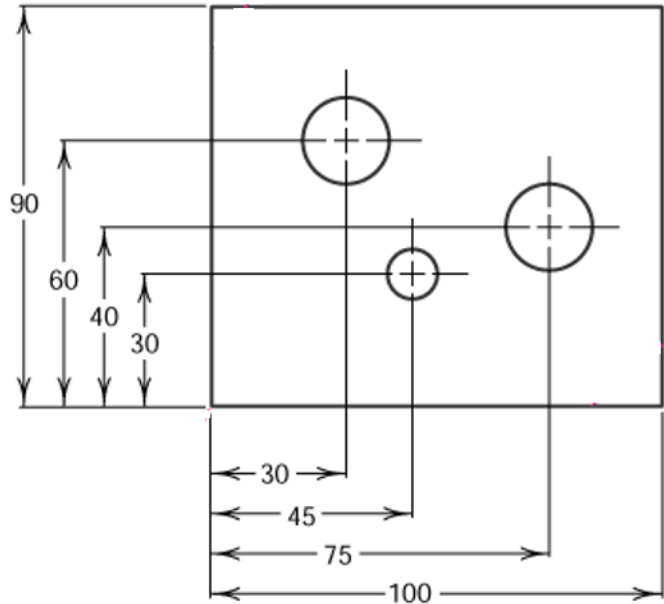

6. Which of the following is **not** a correct rule for decimal inches dimensioning in a drawing?



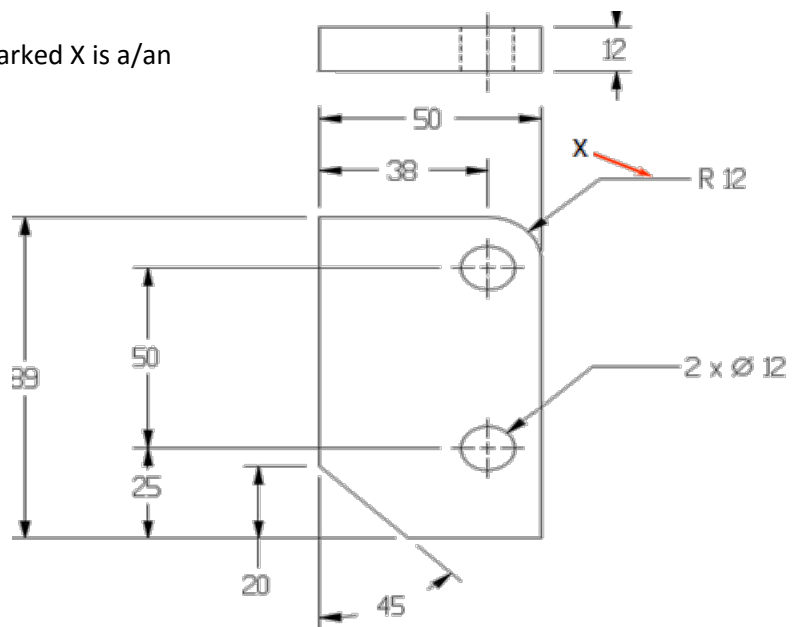

- A. A zero is not used before the decimal point for values less than one inch.
- B. A dimension is expressed to the same number of decimal places as its tolerance.
- C. A 90° angle is implied where centerlines are shown on a drawing at right angles.
- D. The drawing should define parts with specifying manufacturing methods.

7. In the adjacent figure, the element marked X is a/an

- A. dimension line
- B. extension line
- C. centerline
- D. leader

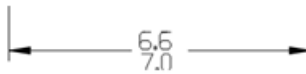

8. Which of the application of tolerancing methods in the following is wrong?

- A. LIMIT 
- B. UNILATERAL (POS) 
- C. UNILATERAL (NEG) 
- D. BILATERAL (EQUAL) 

9. For the adjacent figure, the diameter of the hole at Maximum Material Condition (M) is

- A. 24.950 mm
- B. 25 mm
- C. 25.025 mm
- D. 25.050 mm

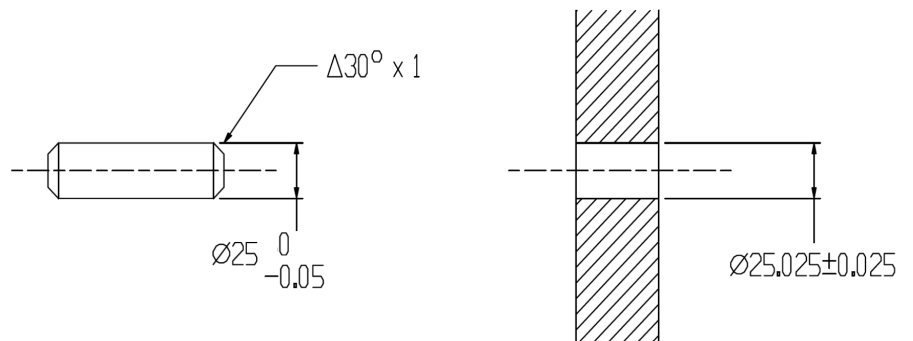

10. The measured diameter for the center bore of the bearing bracket, as shown in the figure below, is 15.01 mm and the measured diametral deviation for the perpendicular geometrical tolerance is 0.06 mm. Is this part acceptable?

- A. Yes, because the limit of size is acceptable (between 15 and 15.11 mm)
- B. Yes, because the geometrical tolerance is less than the total size tolerance of $15.11 - 15 = 0.11$ mm
- C. No, because the limit of size is acceptable but the geometrical tolerance of 0.06 mm exceeds the limits of $\varnothing 0.05$ mm (RFS)
- D. It depends on the subjective judgment of the inspector

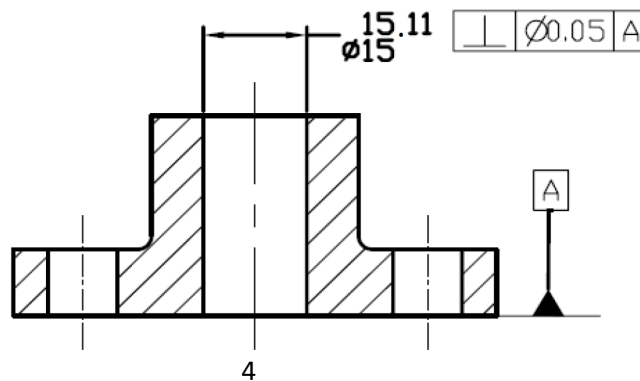

Q2.

(4+4+2)

- (a) Using standard fit tables, calculate the maximum and minimum limits of size of the shaft and hole in the following figure, in both cases of hole based and shaft based system of fits. The nominal diameter of the shaft is **0.875 inches**.

	Fit	ϕ_{\max} Shaft	ϕ_{\min} Shaft	ϕ_{\max} Hole	ϕ_{\min} Hole
<p>LT1</p>					
<p>LT1S</p>					

- (b) From the figure below calculate the maximum and minimum limits of size for the dimension marked "X" and "Y".

$X_{\max} =$

$X_{\min} =$

$Y_{\max} =$

$Y_{\min} =$

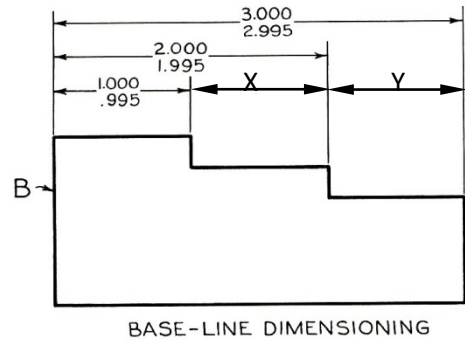

- (c) If coordinate tolerancing zone is used (as shown in figure) what is the distance between extreme permissible positions of holes in the adjacent drawing?

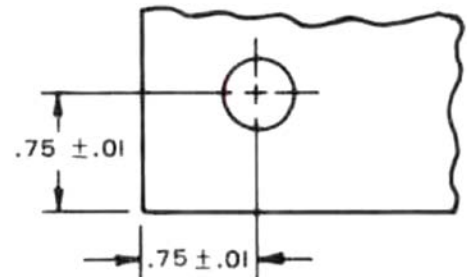

		CONCORDIA UNIVERSITY		MECH 313 - MIDTERM 1 EXAM		FIG. Q3
		SCALE: 1:1		DATE: 14 FEB 2016		PAGE
		DRAWN BY:				

Q4. Given the drawing in **Fig. Q4** and the sentence descriptions of the geometric tolerance information below, correctly dimension the drawing. **(15)**

1. Identify the right-hand surface of the large cylinder in the SIDE VIEW as datum feature A. Control it with a flatness tolerance of .0050.
2. Apply a perpendicularity tolerance to the axis of the .5000-.5075 cylinder in the SIDE VIEW. The feature must be perpendicular with a .0030 cylindrical tolerance zone at MMC relative to datum feature A. Identify the axis of this cylinder as datum feature B.
3. Identify the median plane of the .2925-.2995 slot in the FRONT VIEW as datum feature C. Control this with a position tolerance of .0035 at MMC relative to primary datum feature A and secondary datum feature B at MMC.
4. Make the .5500, 1.0000, and 1.5000 dimensions basic.
5. Add a position tolerance for the .2449-.2480 hole. The hole must be positioned within .0025 of an inch cylindrical tolerance zone at MMC relative to primary datum feature A and secondary datum feature B at MMC.
6. Add a position tolerance for the .1870-.1873 holes. The holes must be positioned within .0001 of an inch cylindrical tolerance zone at MMC relative to primary datum feature A, secondary datum feature B at MMC, and tertiary datum feature C at MMC.
7. In the FRONT VIEW on the horizontal surface of the slot, add a profile of a surface tolerance of .0020 relative to primary datum feature A, secondary datum feature B at MMC, and tertiary datum feature C at MMC.
8. In the FRONT VIEW on the largest diameter, add a profile of a surface tolerance of .0020 relative to primary datum feature A and secondary datum feature B at MMC.

