

Make be sure to read all questions completely & carefully.

1. Life cycle analysis:
 - (a) Extends a products useful life.
 - (b) Encourages reuse and recycling.
 - (c) Evaluates the total environmental impact of a product from manufacturing through application to disposal or recycling.
 - (d) None of the above.
 - (e) All of the above.

2. In the EWB lecture, one of the speakers opened with a short story about a malfunctioning toaster problem. What was the importance of this anecdote?
 - (a) This was a story about the importance of student participation in the EWB organization.
 - (b) Engineers need to have more than just good technical abilities.
 - (c) The story showed how public outreach is an important part of EWB activities.
 - (d) You should eat brown bread instead of white bread because it is healthier.
 - (e) It illustrated how EWB members are often good problem solvers.

3. Which of the following is a true statement about engineering in Canada?
 - (a) In Canada, it is suggested that all work legally defined as engineering be preformed or supervised by a licensed professional engineer.
 - (b) To be a professional engineer in Canada you must be a member or licensee of the National Professional Engineers Society.
 - (c) To be a professional engineer in Canada you must be a member or licensee of a provincial/territorial Association of Professional Engineers.
 - (d) The Canadian Academy of Engineering governs the profession of engineering in Canada.
 - (e) None of statements above are true.

4. Which of the following is a true statement about predicted global power generation situation in 50 to 100 years:
 - (a) Most power will be generated from renewable energy sources.
 - (b) Less power will be consumed per person than currently.
 - (c) Coal will account for a larger portion of power generation than currently.
 - (d) The total power generation capacity of nuclear power plants will remain similar to currently.
 - (e) None of the above statement is true.

5. The category of *Common Pool Resource* problems focus on problems that:
 - (a) Have one unique solution.
 - (b) Can be solved by an interdisciplinary engineering approach.
 - (c) Are impossible to solve.
 - (d) Do not have technical solutions.
 - (e) None of the above.

6. Several environmental agreements and reports have been made over the years. Which of these is generally considered to have been the most successful?

- (a) Kyoto agreement.
- (b) The Bruntland Report.
- (c) The Montreal Protocol.
- (d) The Law of the Sea.
- (e) None of these agreements or reports has had any effect.

7. Which of the following is **not** a basic dimension?

- (a) Electric charge, [e].
- (b) Length, [L].
- (c) Time, [t].
- (d) Weight, [W].
- (e) Temperature, [T].

8. The lecture on Biometrics introduced several security issues related to this technology. Who is that controls the security of Biometric data:

- (a) Government.
- (b) Industry.
- (c) Individuals
- (d) All of the above.
- (e) None of the above.

9. A change of units in a reported measurement changes:

- (a) The magnitude of the measurement.
- (b) The dimension measured.
- (c) The precision of the measurement.
- (d) The accuracy of the measurement.
- (e) All of the above.

Handwritten notes:
~~1000 - 1000~~
1000 - 1000 1

10. In one of the lectures the problem of managing common pool resources was illustrated through the example of commuting to work. In the article "The Tragedy of the Commons" by Garret Hardin, the common pool resource used to first exemplify this type of problem is:

- (a) Overfishing,
- (b) Pollution,
- (c) A pasture of cattle,
- (d) Voting,
- (e) None of the above.

11. A characteristic of all engineering reports is:

- (a) Inclusion of a title page,
- (b) A range of possible outcomes are discussed,
- (c) Clarity and unambiguity,
- (d) They must be at least five pages,
- (e) All of the above,
- (f) None of the above.

12. A series of measurements is determined to have low accuracy and contain a bias. These problems can be corrected by:

- (a) taking the mean of all the measurements,
- (b) calibrating the measuring instrument,
- (c) repeating all the measurements with the same instrument,
- (d) none of the above,
- (e) all of the above.

13. Which of the following is an oblique pictorial?

- (a) Figure A.
- (b) Figure B.
- (c) Figure C.
- (d) All of the above.
- (e) None of the above.

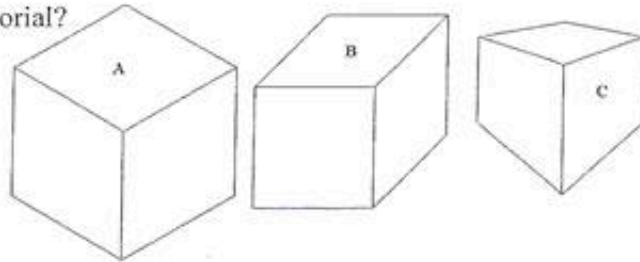

14. The following isometric pictorial started out as a cube. The cube was cut from the front vertex along the diagonal up to the opposite vertex as shown. What will the top view look like in an orthographic projection?

- (a) View A.
- (b) View B.
- (c) View C.
- (d) View D.
- (e) None of the above.

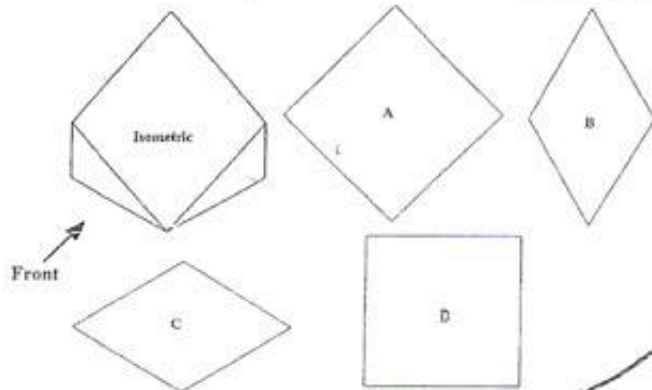

15. By convention holes are dimensioned as the:

- (a) Radius in the view where the hole appears circular.
- (b) Radius in the view where the hole appears rectangular.
- (c) Diameter in the view where the hole appears circular.
- (d) Diameter in the view where the hole appears rectangular.
- (e) None of the above.

16. The following isometric pictorial is a cube with one corner removed. Which two of the three principal orthographic views look the same?

- (a) Top and Right.
- (b) Top and Front.
- (c) Front and Right.
- (d) They are all different.
- (e) None of the above.

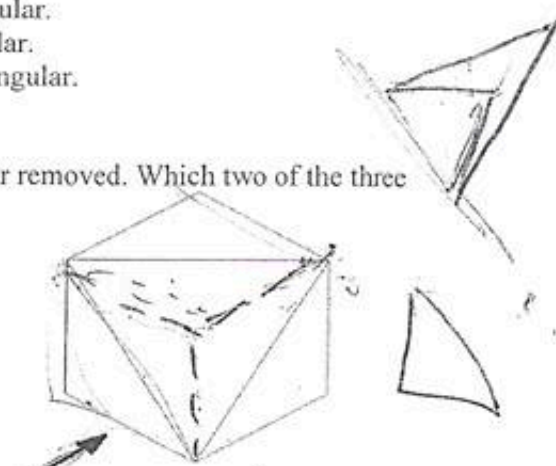

17. Choose the answer giving the correct line type precedence in engineering drawings ('&' indicates equal precedence).

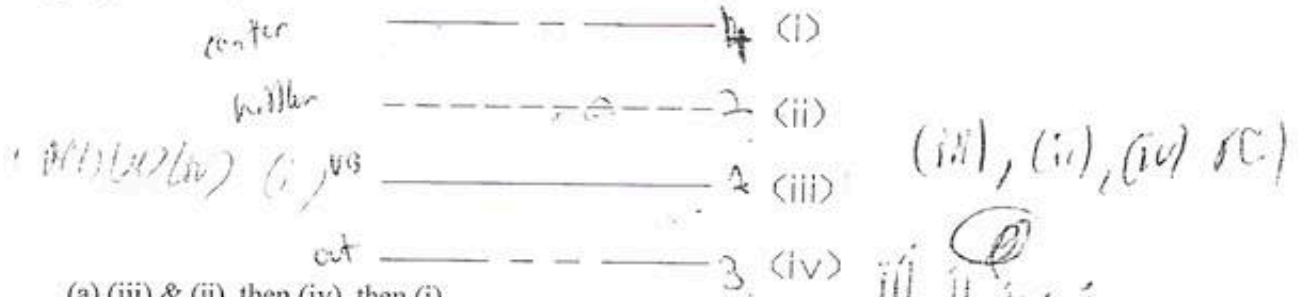

- (a) (iii) & (ii), then (iv), then (i).
- (b) (iii), then (ii), then (iv) & (i).
- (c) (iii), then (iv), then (i) & (ii).
- (d) (iii), then (ii) & (iv), then (i).
- (e) No line type is given preference in an engineering drawing.

18. The front view is missing in the following engineering drawing. How many hidden lines are necessary to complete the front view?

- (a) 4.
- (b) 3.
- (c) 2.
- (d) 1.
- (e) None.

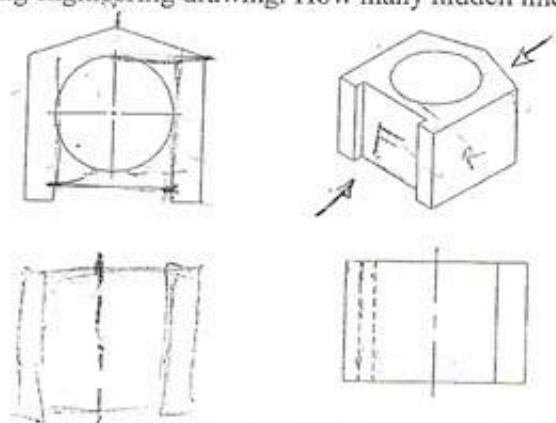

19. Consider the pictorial view of the object shown below. What is the minimum number of views necessary in a detail drawing to completely and unambiguously describe its geometry for manufacturing purposes?

- (a) An isometric view.
- (b) One oblique view.
- (c) Two orthographic views.
- (d) Three orthographic views.
- (e) Both answers (a) and (b) are correct.

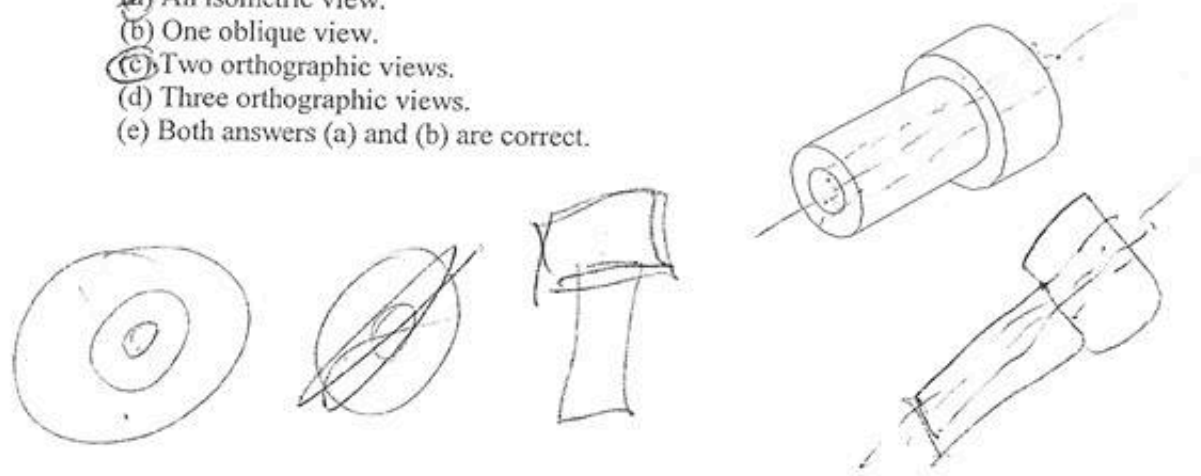

24. The number 3.14159 is divided by 2.63. The result should be reported to how many significant figures?

- (a) 2.
- (b) 3.
- (c) 4.
- (d) 5.
- (e) 6.

25. The difference between the true value of a dimension and its measured value is known as:

- (a) Measurement.
- (b) Significant figures.
- (c) Measurement error.
- (d) Measurement calibration.
- (e) None of the above.

26. A slug is:

- (a) A basic dimension.
- (b) A derived dimension.
- (c) A unit of weight.
- (d) A unit of mass.
- (e) None of the above.

27. An appendix to a Final Report should not include which of the following?

- (a) Recommendations.
- (b) Raw data.
- (c) Correspondence.
- (d) Sketches.
- (e) All of the above belong in appendices.

28. In which types of drawing can true length measurements be made in the front plane?

- (a) Oblique.
- (b) One point perspective.
- (c) Two point perspective.
- (d) Isometric.
- (e) Axonometric.

29. How should the front view of an orthographic projection be selected?

- (a) Whichever view is convenient.
- (b) The longest side.
- (c) Any side without hidden features.
- (d) The most descriptive view.
- (e) None of the above.

30. In the orthogonal drawing shown below left, two of the views shown are incomplete. Which of options (a) to (d) is complete and correct?

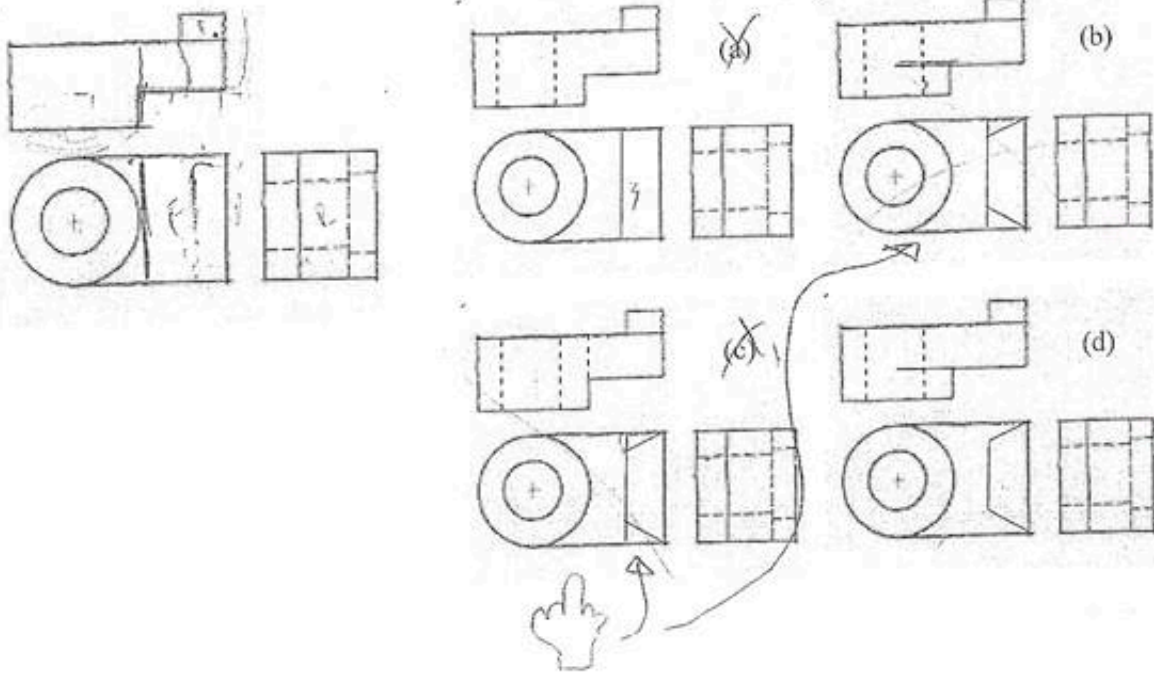

20. Given the isometric pictorial below, how many hidden lines should appear in the top view of an orthographic projection?

- (a) 2.
- (b) 4.
- (c) 6.
- (d) 8.
- (e) None of the above.

29.1
29.01

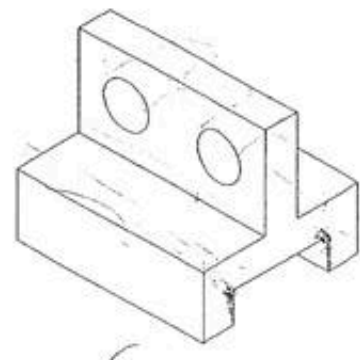

21. Given the following isometric drawing, choose the appropriate front view in an orthographic projection?

- (a) Figure A.
- (b) Figure B.
- (c) Figure C.
- (d) Figure D.
- (e) None of the above.

0.91
0.091
0.00091

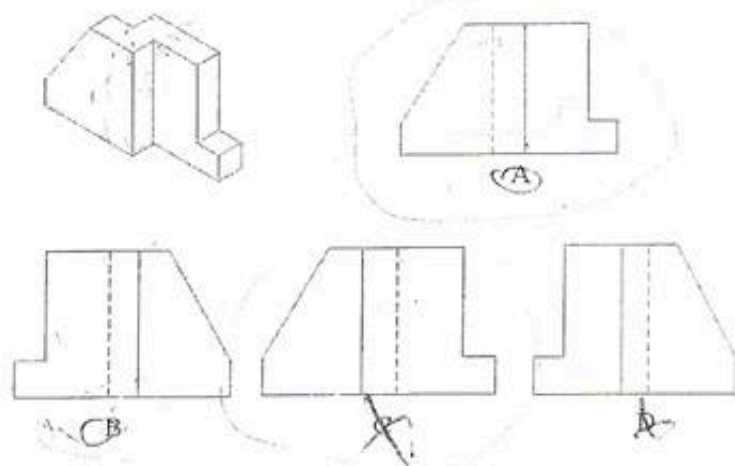

22. What is the sum of the numbers 9.11, 7.133, and 13 taking into account significant figures and rounding?

- (a) 29.0.
- (b) 29.2.
- (c) 29.24.
- (d) 29.234.
- (e) None of the above.

if this 0 non-significant

$$\begin{array}{r} 029.0 \\ 7.133 \\ \hline 29.00 \end{array}$$
 2.133
29.234

23. A length is measured and reported as 3.8 m. This implies that the resolution of the measurement instrument, and hence the assumed precision of the measurement is:

- (a) ± 0.01 m.
- (b) ± 0.05 m.
- (c) ± 0.005 m.
- (d) ± 0.1 m.
- (e) None of the above.

$$\sqrt{-\pi}^{\sqrt{\pi}} = \pi^{\sqrt{\pi}}$$

145
83