

**Department of Physics**  
**PCS 211 – Physics: Mechanics**

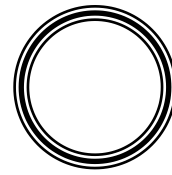

Please insert in the circle the  
initial of your last name

**Please Print Clearly:**

**Student:** \_\_\_\_\_  
*Last Name* *First Name*

**Student Number:** \_\_\_\_\_ **Student Section:** \_\_\_\_\_

## Midterm Test – October 28, 2011

**Check the name of your professor:**

Dr. Chithrani

Dr. Hu

Dr. Tavakkoli

Dr. Toronov

Dr. Yuan

**Read the following attentively**

- **Ensure that your name and student number are correct in the bubble sheet.**
- **Duration of the exam is 90 minutes.**
- **The exam consists of 1 full-answer question and 10 multiple-choice questions. Answer ALL questions.**
- **Each multiple-choice question has 1 mark.**
- **For each multiple choice question:**
  - You need to show, in the space provided in this booklet, a justification for your answer. If no work or correct argument is shown, the resultant mark may be zero, even if the answer in the bubble sheet is correct.
  - The work shown in your exam booklet may be checked, **at least for one** of the questions, selected randomly.
  - **Transfer your choices to the bubble sheet only when you're sure of them.**
  - Some answers may be rounded off.
- **Pagers and cell phones must be silenced and placed out of reach. Hats and earphones are not allowed. If a phone rings, its owner is responsible for disrupting the exam and the phone will be confiscated or the owner will be asked to leave the room resulting in a zero on the test.**
- **Sharing of pencils, erasers and calculators is not permitted.**
- **Talking to another student or glancing over another student's paper is not permitted and may result in a charge of academic misconduct.**
- **The calculator models allowed for the test are either Sharp EL-546 or Casio FX-991 (or versions of these models). If you are found to have another type of calculator, it may be confiscated for the duration of the test.**
- **The exam booklet has a total of 8 pages. You are responsible for checking that you have all pages.**

---

*Sign here to signify you read the instructions*

### Full Answer Question (5 marks)

The 100-kg crate is supported by 4 cables in equilibrium as shown in the figure.

Answers to the following questions should be inserted in the boxes provided. Show all works in spaces provided. DO NOT FORGET UNITS!

**Part I (0.4 mark)**

Draw the free body diagram for the point A in the box below.

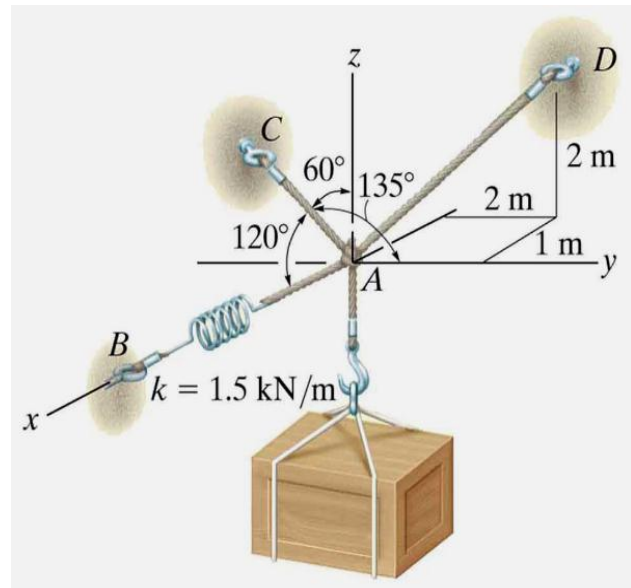
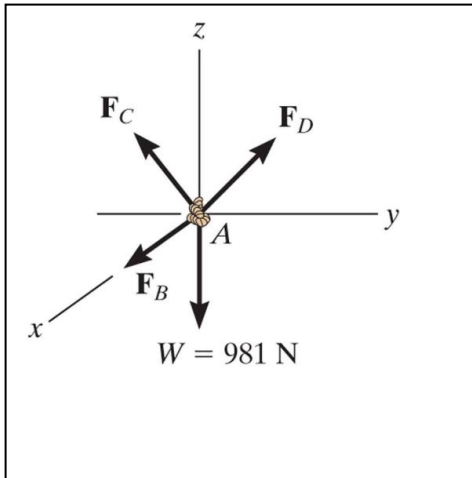

**Part II (1.6 marks)**

The unit vector along cable AB is  $\mathbf{u}_{AB} =$

The unit vector along cable AC is  $\mathbf{u}_{AC} =$

The unit vector along cable AD is  $\mathbf{u}_{AD} =$

The 100-kg crate is supported by 4 cables in equilibrium as shown in the figure.

**Part III (3 marks)**

Solve the equations of equilibrium to find the tension magnitudes in the cables.

$$T_{AB} = 694 \text{ N}$$

$$T_{AC} = 813 \text{ N}$$

$$T_{AD} = 862 \text{ N}$$

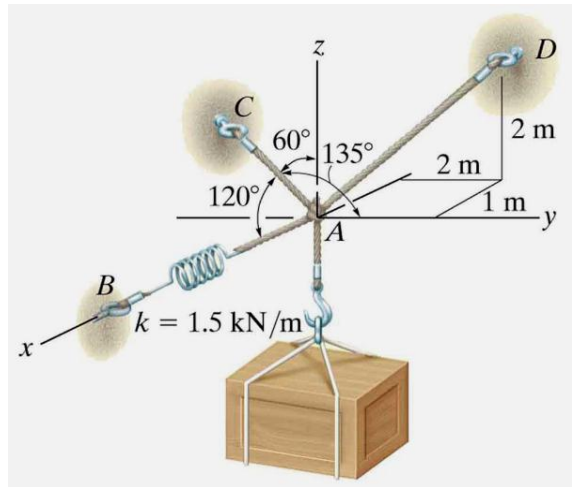

## Multiple-choice Questions (10 marks)

1. The equation for the change of position of an object starting at  $x = 0$  m is given by

$$x(t) = \frac{1}{2}at^2 + bt^3, \text{ where } a \text{ and } b \text{ are constants. The dimensions of } b \text{ are}$$

- (a)  $T^{-3}$       (b)  $LT^{-3}$       (c)  $LT^{-2}$       (d)  $LT^{-1}$       (e)  $L^{-1}T^{-1}$

2. Determine the direction of the resultant force acting on the bracket measured counterclockwise from the  $u$  axis.

- (a)  $63.1^\circ$   
 (b)  $18.1^\circ$   
 (c)  $3.1^\circ$   
 (d)  $108.1^\circ$   
 (e) None of the above.

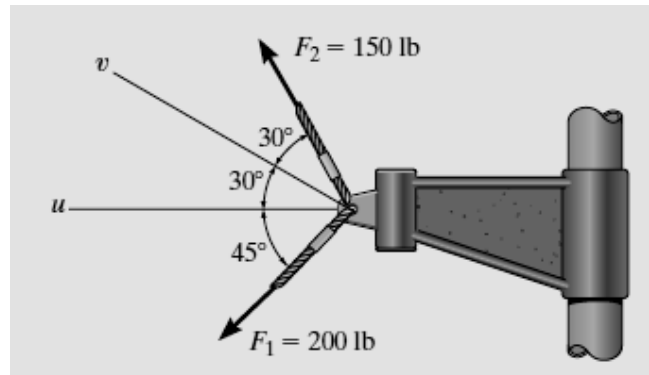

3. If the resultant force acting on the bracket is to be directed along the positive  $x$  axis and the magnitude of  $F_1$  is required to be a minimum, determine the magnitude of the resultant force.

- (a) 420 lb
- (b) 80 lb
- (c) 340 lb
- (d) 140 lb**
- (e) None of the above.

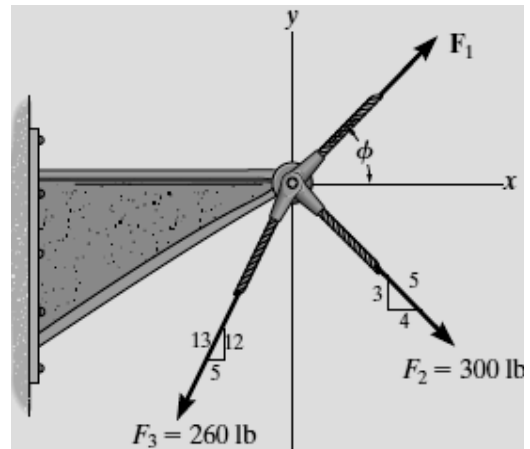

4. The screw eye is subjected to two forces. Find the magnitude and the coordinate direction angles of the resultant force.

- (a) 570 N,  $86^\circ$ ,  $4.0^\circ$ ,  $89^\circ$
- (b) 730 N,  $51^\circ$ ,  $39^\circ$ ,  $89^\circ$
- (c) 700 N,  $52^\circ$ ,  $40^\circ$ ,  $98^\circ$
- (d) 550 N,  $83^\circ$ ,  $13^\circ$ ,  $100^\circ$
- (e) 480 N,  $73^\circ$ ,  $17^\circ$ ,  $89^\circ$**

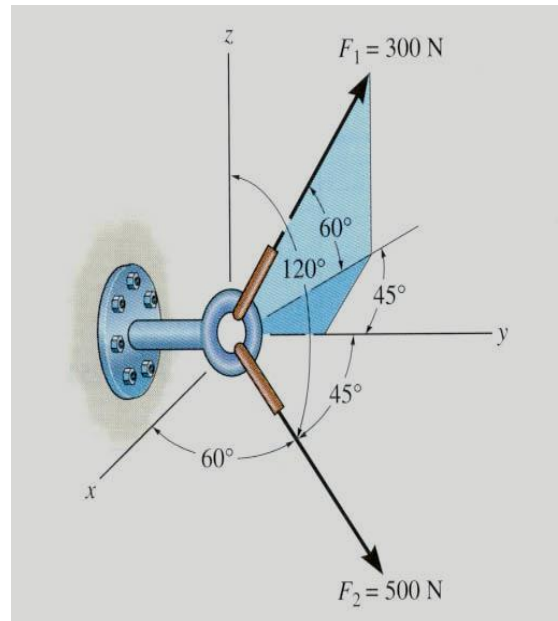

5. The force is acting on the pole. Find the magnitude of the projection of the force along the pole  $AO$ .

- (a) 31 lb
- (b) 2.9 lb
- (c) 3.1 lb
- (d) 4.1 lb
- (e) 0.41 lb

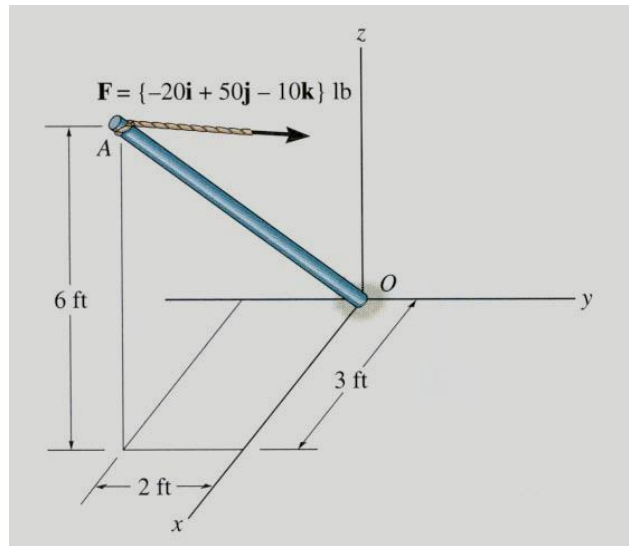

6. Determine the unstretched length of spring  $AC$  if a force  $P = 80$  lb causes the angle  $\theta = 60^\circ$  for equilibrium. Cord  $AB$  is 2 ft long and the spring's constant is  $k = 50$  lb/ft.

- (a) 0.633 ft
- (b) 1.33 ft
- (c) 0.533 ft
- (d) 2.66 ft
- (e) 0.133 ft

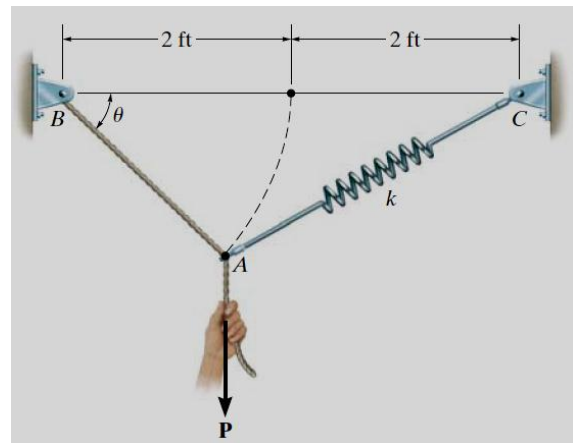

7. For  $\theta = 37^\circ$ , if the force  $\mathbf{F}$  has magnitude of 100 N, what is the magnitude and direction of moment of the force  $\mathbf{F}$  about point  $O$ ?

- (a) 23.6 N.m out of the paper
- (b) 15.7 N.m into the paper
- (c) 15.7 N.m out of the paper
- (d) 23.6 N.m into the paper
- (e) None of the above.

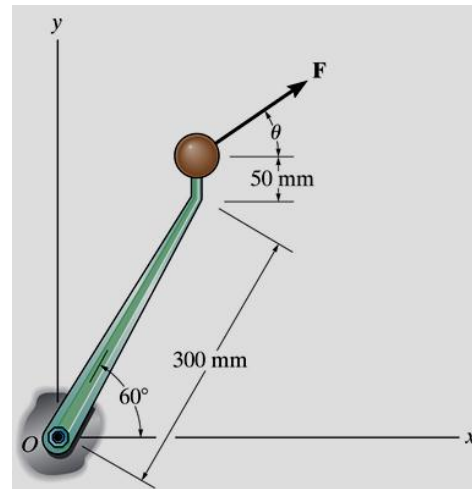

8. Determine the moment produced by force  $\mathbf{F}$  about segment  $AB$  of the pipe assembly. Express the result as a Cartesian vector.

- (a)  $[-52.8\mathbf{i} - 70.4\mathbf{j} - 1.10\mathbf{k}] \text{ N}\cdot\text{m}$
- (b)  $[1.56\mathbf{i} - 0.750\mathbf{j} - 1.00\mathbf{k}] \text{ kN}\cdot\text{m}$
- (c)  $[-52.8\mathbf{i} - 70.4\mathbf{j}] \text{ N}\cdot\text{m}$
- (d)  $[-52.8\mathbf{i} + 70.4\mathbf{j} + 100\mathbf{k}] \text{ N}\cdot\text{m}$
- (e)  $[+52.8\mathbf{i} - 70.4\mathbf{j} + 10\mathbf{k}] \text{ kN}\cdot\text{m}$

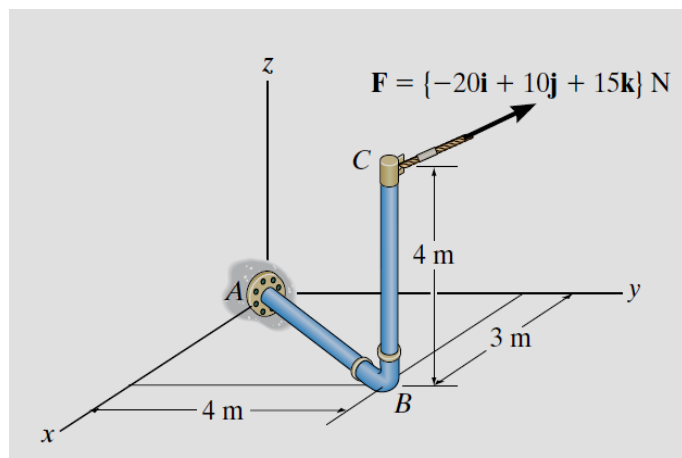

9. Determine the resultant moment produced by forces  $\mathbf{F}_B$  and  $\mathbf{F}_C$  about point  $O$  as a Cartesian vector.

- (a)  $[720\mathbf{i} - 720\mathbf{j}] \text{ N}\cdot\text{m}$
- (b)  $[-720\mathbf{i} + 720\mathbf{j}] \text{ N}\cdot\text{m}$
- (c)  $[360\mathbf{i} - 360\mathbf{j}] \text{ N}\cdot\text{m}$
- (d)  $[-360\mathbf{i} + 360\mathbf{j}] \text{ N}\cdot\text{m}$
- (e)  $[180\mathbf{i} - 180\mathbf{j}] \text{ N}\cdot\text{m}$

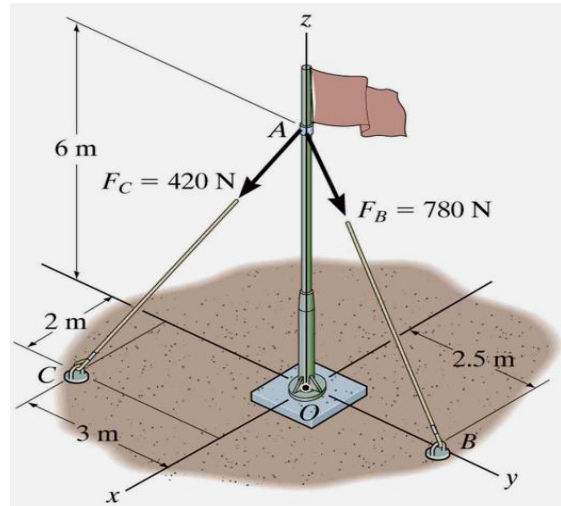

10. Two couples act on the cantilever beam. If  $F = 6 \text{ kN}$ , determine the resultant couple moment.

- (a)  $6.85 \text{ kN}\cdot\text{m}$
- (b)  $-6.85 \text{ kN}\cdot\text{m}$
- (c)  $-8.33 \text{ kN}\cdot\text{m}$
- (d)  $5.20 \text{ kN}\cdot\text{m}$
- (e)  $-5.20 \text{ kN}\cdot\text{m}$

